

(19) **DANMARK**



Patent- og
Varemærkestyrelsen

(10) **DK/EP 2599710 T3**

(12) **Oversættelse af
europæisk patentskrift**

-
- (51) Int.Cl.: **B 63 B 35/44 (2006.01)** **B 63 J 2/02 (2006.01)** **B 63 J 2/10 (2006.01)**
E 21 B 15/00 (2006.01) **E 21 B 15/02 (2006.01)** **F 24 F 7/06 (2006.01)**
F 24 F 13/08 (2006.01) **F 24 F 13/10 (2006.01)**
- (45) Oversættelsen bekendtgjort den: **2016-07-04**
- (80) Dato for Den Europæiske Patentmyndigheds bekendtgørelse om meddelelse af patentet: **2016-04-20**
- (86) Europæisk ansøgning nr.: **11812700.0**
- (86) Europæisk indleveringsdag: **2011-06-22**
- (87) Den europæiske ansøgnings publiceringsdag: **2013-06-05**
- (86) International ansøgning nr.: **KR2011004557**
- (87) Internationalt publikationsnr.: **WO2012015170**
- (30) Prioritet: **2010-07-27 KR 20100072573**
- (84) Designerede stater: **AL AT BE BG CH CY CZ DE DK EE ES FI FR GB GR HR HU IE IS IT LI LT LU LV MC MK MT NL NO PL PT RO RS SE SI SK SM TR**
- (73) Patenthaver: **Daewoo Shipbuilding&Marine Engineering Co., Ltd., 85 Da-dong , Jung-gu, Seoul 100-180, Sydkorea**
Transocean Sedco Forex Ventures Limited, 70 Harbour Drive, 4th Floor, George Town, Grand Cayman, Caymanøerne
- (72) Opfinder: **CHOO, Keum Dae, 106-704 Deoksan 1-Cha APT., Gohyeon-dong, Geoje Si, Gyeongsangnam-do 656-763, Sydkorea**
LEE, Yu Young, 28-205 Okrim APT., Majeon-dong, Geoje Si, Gyeongsangnam-do 656-752, Sydkorea
CHOI, Jung Yul, C-413 Dumo Dormitory, Dumo-dong, Geoje Si, Gyeongsangnam-do 656-080, Sydkorea
KANG, Jung Soo, 102-1302 Posco The-sharp, Yangjeong-dong, Geoje-si, Gyeongsangnam-do 656-306, Sydkorea
BRITTIN, Scott, D., 23 Lakefield Trails, Katy, TX 77493-4949, USA
- (74) Fuldmægtig i Danmark: **Budde Schou A/S, Hausergade 3, 1128 København K, Danmark**
- (54) Benævnelse: **Ventilationsapparat til et boreskib**
- (56) Fremdragne publikationer:
JP-A- 2000 238 695
KR-Y1- 200 226 940
KR-Y1- 200 431 766
US-A- 4 613 001
US-A- 5 044 830
US-A- 5 072 656

DESCRIPTION

BACKGROUND OF THE INVENTION

Field of the Invention

[0001] The present invention relates to a drill ship, and more particularly, to a ventilating apparatus for a drill ship, which allows the drill ship sailing around an arctic region to maintain appropriate temperature and pressure.

Description of the Related Art

[0002] Due to the rapid international industrialization and industrial development, the use of the earth's resources, such as oil, is gradually increasing. Accordingly, stable production and supply of oil is emerging as a very important worldwide issue.

[0003] For this reason, much attention has recently been paid to development of mall marginal fields or deep-sea oil fields, which have been ignored because of their low economic feasibility. Therefore, with the development of offshore drilling techniques, drill ships equipped with drilling equipment suitable for development of such oil fields have been developed.

[0004] In a conventional offshore drilling, rig ships or fixed type platforms have been mainly used, which can be moved only by tugboats and are anchored at a position on the sea using a mooring gear to conduct an oil drilling operation. In recent years, however, so-called drill ships have been developed and used for offshore drilling. The drill ships are provided with advanced drilling equipments and have structures similar to typical ships such that they can make a voyage using their own power.

[0005] Meanwhile, a moonpool is formed at the center of a drill ship equipped with a variety of drilling equipments, such that a riser or a drill pipe for drilling oil or gas existing under the sea bed is vertically movable through the moonpool.

[0006] FIG. 1 is a side view illustrating a conventional drill ship which performs a drilling operation on the sea.

[0007] A derrick 2 is fixedly installed on a deck of a drill ship 1. The derrick 2 is a large complicated structure provided with beams and a variety of drilling equipments. The derrick 2 is a type of a tower in which all drilling equipments installed around the moonpool 3 of the drill ship 1 are integrated. In addition, the derrick 2 is provided for vertically moves the drilling equipment such as a drill pipe 5. The derrick 2 vertically moves the drilling equipment to a desired position by winding or unwinding a wire rope coupled to the drilling equipment by a winch operation. The drill ship 1 may use one derrick or two derricks.

[0008] A worker drills submarine resources stored in an oil well 13, which is located in a reservoir 12 under a sea bed 6, by moving a riser 4 and a drill pipe 5 downwardly through the moonpool 3 formed at the center of the drill ship 1.

[0009] The riser 4 is a member that previously moves to the sea bed 6 before the drill pipe 5 moves downwardly to the oil well 13, and it provides a passage through which mud is returned. When the riser 4 is installed, the drill pipe 5 moves downwardly through a sea bed layer 11 to the oil well 13 along the inside of the riser 4.

[0010] In the case where the riser moves downwardly to the sea bed 6 or the drill pipe 5 moves downwardly to the oil well 13, short risers 4 or short drill pipes 5 are coupled together and move downwardly. A blowout preventer (BOP) 7 is installed on the sea bed 6 to prevent abnormal pressure from blowing out along the drill pipe 5. A casing 8 is fixed to the sea bed layer 11 by cement, and the drill pipe 5 with a drill bit 10 is inserted into the casing 8. Then, the submarine resources are drilled. The drill bit 10 may be overheated by heat generated when the drill bit 10 drills the ground. Therefore, a mud 9 is inserted into the drill pipe 5 in order to prevent the overheating of the drill bit 10, and the mud 9 serves to lubricate the drill bit 5, thereby further facilitating the drilling operation. The mud 9 is discharged out of the drill bit 10 and is returned through the casing 8 and the riser 4. When the drilling operation is completed, the drill pipe 5 is carried to a drill floor through the moonpool 3 and then is separated and delivered to a storage facility.

[0011] In the case of the conventional drill ship, as described above, the derrick has an opened structure in which steel pipes are coupled together, like a power transmission tower installed on the ground. Therefore, natural ventilation is possible without any

separate mechanical ventilating apparatus.

[0012] However, if the conventional derrick having the opened structure is installed in a drill ship which sails around an arctic region, a variety of drilling equipments are exposed at below zero temperatures for a long time. Consequently, the drilling equipments may not operate normally.

[0013] Document JP 2000-238695 discloses an exhaust system mountable on a manhole.

[0014] In the document US 5,044,830, an example of a gravity base structure is shown.

[0015] Further, in the document US 4,613,001, an example of a drilling rig is disclosed.

[0016] The document US 5,072,656 shows a drilling apparatus, whereby air in a pipe shelter is heated to provide a comfortable temperature environment. Thereby, the air in the pipe shelter is trapped in the pipe shelter.

[0017] According to the invention, there is provided a ventilating apparatus for a drill ship as defined by the features of independent claim 1.

[0018] Further advantageous features of the invention are defined in the dependent claims.

BRIEF DESCRIPTION OF THE DRAWINGS

[0019]

FIG. 1 is a side view illustrating a conventional drill ship which performs a drilling operation on the sea.

FIG. 2 is a conceptual diagram illustrating a situation in which a ventilating apparatus for a drill ship sailing around an arctic region is operating in a hot season.

FIG. 3 is a conceptual diagram illustrating a situation in which a ventilating apparatus for a drill ship sailing around an arctic region is operating in a cold season.

<Reference Numerals>

100: drill ship	110: derrick
111: pressure regulating damper	120: moonpool
130: air supply device	131: supply fan
132: supply louver	133: shut-off damper
134: heater	136: duct
137: wire mesh	140: air exhaust device
141: exhaust fan	142: exhaust louver
150: air supply port	160: heat blower

DETAILED DESCRIPTION OF EXEMPLARY EMBODIMENTS

[0020] Exemplary embodiments of the present invention will be described below in detail with reference to the accompanying drawings.

[0021] FIG. 2 illustrates a situation in which a ventilating apparatus for a drill ship sailing around an arctic region is operating in the hot season.

[0022] A derrick 110 and a moonpool 120 are ventilated through a ventilating apparatus according to the present invention. The derrick 110 is fixedly installed on a deck (not shown) of a drill ship 100 and the moonpool 120 is formed under the derrick 110, such that drills for a drilling operation or the like move downwardly through the derrick 100 and the moonpool 120. Since this is

well known in the shipbuilding industry, detailed description thereof will be omitted for conciseness.

[0023] Since the drill ship 100 to which the present invention is applied sails around the arctic region, the derrick 110 has an enclosed structure blocked from the exterior so as to prevent air having a temperature below zero from being directly contacted with a variety of drilling equipments inside the derrick 110.

[0024] Although the terms "hot season" and "cold season" are used in this specification, they represent the conditions of the arctic region and thus it should be noted that a temperature does not exceed 10°C even in a hot season.

[0025] Even when the drill ship 100 sails around the arctic region, the ventilating apparatus according to the embodiment of the present invention can prevent the internal temperature of the drill ship 100 from dropping rapidly and can constantly maintain temperature and pressure suitable for sailing and drilling.

[0026] To this end, an air supply device 130 installed outside the derrick 110 supplies fresh outside air through a supply fan 131. However, in the case where the ventilating apparatus according to the present invention operates in a hot season, air is not separately heated through a heater 134 of the air supply device 130, considering the temperature of the outside air. The outside air supplied through the air supply device 130 may flow through a duct 136 to a space where the moonpool 120 is formed.

[0027] The end of the duct 136 may be coupled to the derrick 110. However, in terms of circulation of outside air, it is more advantageous to couple the end of the duct 136 to the moonpool 120 disposed under the derrick 110, because air can be ventilated through the whole derrick 110.

[0028] A wire mesh 137 is formed at the end of the duct 136 coupled to the moonpool 120, whereby air can be effectively supplied to the moonpool 120.

[0029] The air supply device 130 includes a supply louver 132 which can allow the inflow of outside air and prevent the inflow of large particles or rainwater. In addition, the air supply device 130 includes a shut-off damper 133 which can shut off an air flow in the event of a fire or other emergency.

[0030] An air supply port 150 is formed on the side of the derrick 110. The air supply port 150 may be opened in a hot season. Accordingly, outside air may flow into the derrick 110 through the air supply port 150 as well as the air supply device 130.

[0031] In the case where the drill ship 100 according to the present invention sails around the arctic region in a hot season, the supply fan 131 and an exhaust fan 141 may be operated at high speed to supply and exhaust air at high speed. To be specific, since a temperature in a hot season is relatively high as compared to a cold season, it is less likely that the derrick 110 and the moonpool 120 will be frozen. Therefore, the outside air need not stay in a space formed by the derrick 110 and the moonpool 120 for a long time. In a hot season, outside air also flow into the derrick 110 through the air supply port 150, as described above. Therefore, an amount of air for ventilation is sufficient.

[0032] The outside air supplied to the moonpool 120 flows upwardly, passes through the derrick 110, and are exhausted out of the derrick 110 through the exhaust fan 141 installed in an air exhaust device 140, as indicated by arrows. In such a manner, fresh air is continuously supplied to the moonpool 120 and the derrick 110. Accordingly, even though gas or the like is generated during a drilling operation, it is exhausted immediately to the exterior, thereby ensuring the safety of operations in spite of the use of the derrick 110 having the enclosed structure.

[0033] As illustrated in FIG. 2, an exhaust louver 142 may be provided in the air exhaust device 140. The exhaust louver 142 can allow the exhaust of air and prevent the inflow of large particles or rainwater from the exterior.

[0034] Since the derrick 110 has the enclosed structure, the internal pressure of a compartment formed by the moonpool 120 and the derrick 110 may rise or drop excessively if waves hit the opened space under the moonpool 120 which is in contact with seawater. To prevent such a rapid pressure variation and maintain the internal pressures of the derrick 110 and the moonpool 120 at constant levels, a pressure regulating damper 111 may be installed on the side of the derrick 110 as illustrated in FIG. 2. The pressure regulating damper 111 suctions or exhausts air according to a variation in the internal pressures of the derrick 110 and the moonpool 120.

[0035] FIG. 3 illustrates a situation in which a ventilating apparatus for a drill ship sailing around an arctic region is operating in a cold season.

[0036] Since the operation of the ventilating apparatus of the present invention in the cold season is almost identical to the operation in the hot season, the following description will be focused on differences therebetween.

[0037] In the cold season of the arctic region, air temperature outside the drill ship 100 is below zero and it is extremely cold. Therefore, cold outside air flowing into the air supply device 130 is heated to an appropriate temperature by the heater 134 and is supplied to the moonpool 120 and the derrick 110.

[0038] In addition, considering below zero temperatures outside the drill ship 100, air heated by the heater 134 needs to stay in the space formed by the derrick 110 and the moonpool 120 for a long time. Therefore, the supply fan 131 and the exhaust fan 141 may be operated more slowly than in the hot season.

[0039] It is preferable to close the air supply port 150 formed on the side of the derrick 110. Since outside air temperature is extremely low, a variety of drilling equipments may be frozen if air is supplied to the derrick 110 without being heated by the heater 134 or the like.

[0040] A plurality of heat blowers 160 may be installed inside the derrick 110 to heat air and forcibly circulate the heated air. Although the air heated by the heater 134 is supplied to the moonpool 120 and the derrick 110, a more effective air ventilation may be achieved by installing an additional heat source, separately from the heater 134, in the inside of the derrick 110, considering the cold season.

[0041] According to the ventilating apparatus for the drill ship of the present invention, ventilation of warm air into the drill ship makes it possible to meet a temperature maintenance condition required when the drill ship sails around the arctic region. In addition, it is possible to minimize the rapid pressure change due to the influence of waves generated in the moonpool.

[0042] In addition, energy can be efficiently used by partially changing the method for operating the ventilating apparatus of the drill ship, depending on the cold season and the hot season of the arctic region.

[0043] According to the embodiments of the present invention, the ventilating apparatus for the drill ship can maintain temperatures and pressures of the moonpool and the derrick at appropriate levels, considering the influence of temperature and wave, such that the drill ship is smoothly operating in an arctic region.

[0044] Since the derrick and the moonpool have the enclosed spaces blocked from the exterior in order for preventing freezing, it is possible to minimize the influence of the temperature and pressure of the space formed by the derrick and the moonpool according to the external temperature and waves.

[0045] Moreover, since the pressure regulating damper prevents the excessive pressure change in the derrick and the moonpool, it is possible to prevent the generation of excessive positive pressure and negative pressure even though waves hit in the moonpool.

[0046] While the ventilating apparatus for the drill ship according to the present invention has been described with reference to the specific embodiments, it will be apparent to those skilled in the art that various changes and modifications may be made without departing from the scope of the invention as defined in the following claims.

REFERENCES CITED IN THE DESCRIPTION

This list of references cited by the applicant is for the reader's convenience only. It does not form part of the European patent document. Even though great care has been taken in compiling the references, errors or omissions cannot be excluded and the EPO disclaims all liability in this regard.

Patent documents cited in the description

- [JP2000238695A](#) [0013]
- [US5044830A](#) [0014]
- [US4613001A](#) [0015]

- US5072656A [0016]

PATENTKRAV

1. Ventilationsapparat til et boreskib (100), som omfatter en derrick (110), som danner et lukket rum, som er blokeret fra omgivelserne og en moonpool (120) udformet under derrickken (110), omfattende:
- 5 en luftforsyningsindretning (130), som forsyner omgivende luft til moonpoolen (120) eller derrickken (110); og en luftudsugningsindretning, som udsuger den tilførte omgivende luft ud af toppen af derrickken (110),
- 10 hvor derrickken omfatter et trykregulerende spjæld (111), som tilfører eller udsuger luft således, at et indvendigt tryk i derrickken opretholdes konstant.
2. Ventilationsapparat ifølge krav 1, hvor luftforsyningsindretningen (130) omfatter en varmeindretning (134), som opvarmer den omgivende luft.
- 15 3. Ventilationsapparat ifølge krav 1, hvor luftforsyningsindretningen (130) omfatter et aflukningsspjæld, som aflukker en luftstrømning, når en nødsituation forekommer, medens boreskibet sejler.
4. Ventilationsapparat ifølge krav 1, hvor luftforsyningsindretningen (130) omfatter et
- 20 forsyningsjalousi (132), som forhindrer indstrømning af partikler udover luft.
5. Ventilationsapparat ifølge krav 1, hvor derrickken (110) omfatter en luftforsyningsåbning, som kan åbnes og lukkes, igennem hvilken den omgivende luft tilføres.
- 25 6. Ventilationsapparat ifølge krav 1, som yderligere omfatter en varmeblæser tilvejebragt indvendigt i derrickken for at opvarme luft med henblik på effektiv ventilation.
7. Ventilationsapparat ifølge krav 1, hvor luftudsugningsindretningen omfatter et
- 30 udsugningsjalousi, som forhindrer indstrømning af partikler udover luft.
8. Ventilationsapparat ifølge krav 1, hvor
- en forsyningsblæser (131) er installeret i luftforsyningsindretningen,
- en udsugningsblæser (141) er installeret i luftudsugningsindretningen, og
- driftshastighederne for forsyningsblæseren og udsugningsblæseren ændres afhængigt
- 35 af temperaturen for den omgivende luft.

9. Ventilationsapparaturl ifølge krav 1, hvor luftforsyningsindretningen (130) forsyner den omgivende luft til moonpoolen eller til derricken via en kanal, og et trådflet er tilvejebragt ved enden af kanalen, som er forbundet med moonpoolen eller derricken.

DRAWINGS

Fig. 1

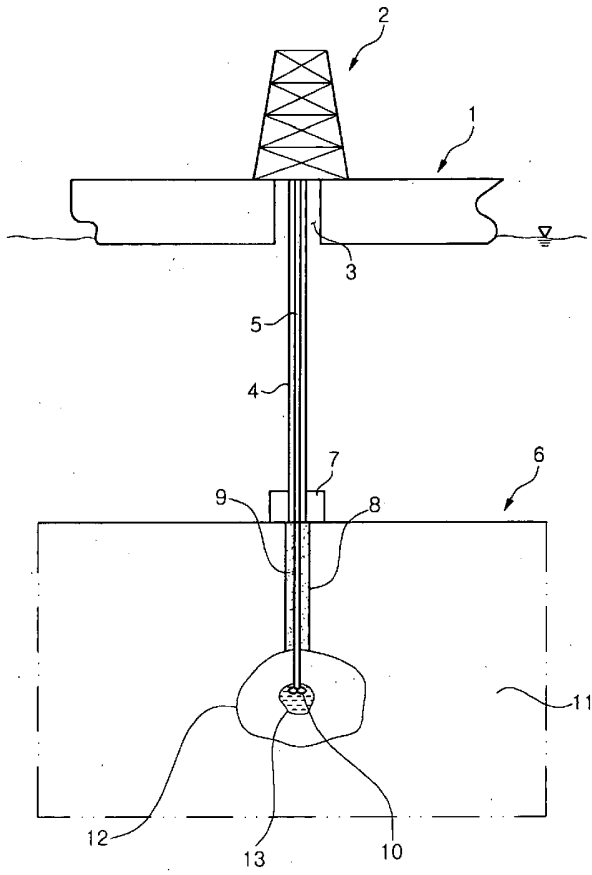

Fig. 2

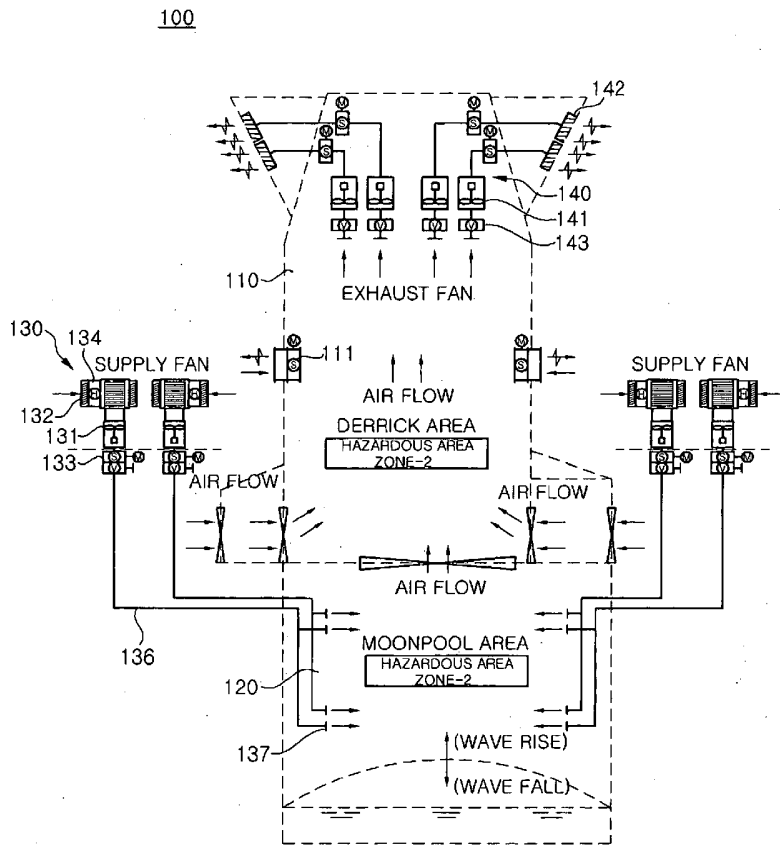

Fig. 3

