

Sept. 15, 1925.

1,553,955

P. D. PARSONS

MACHINE FOR MAKING PAPER ARTICLES

Filed Aug. 20, 1923

2 Sheets-Sheet 1

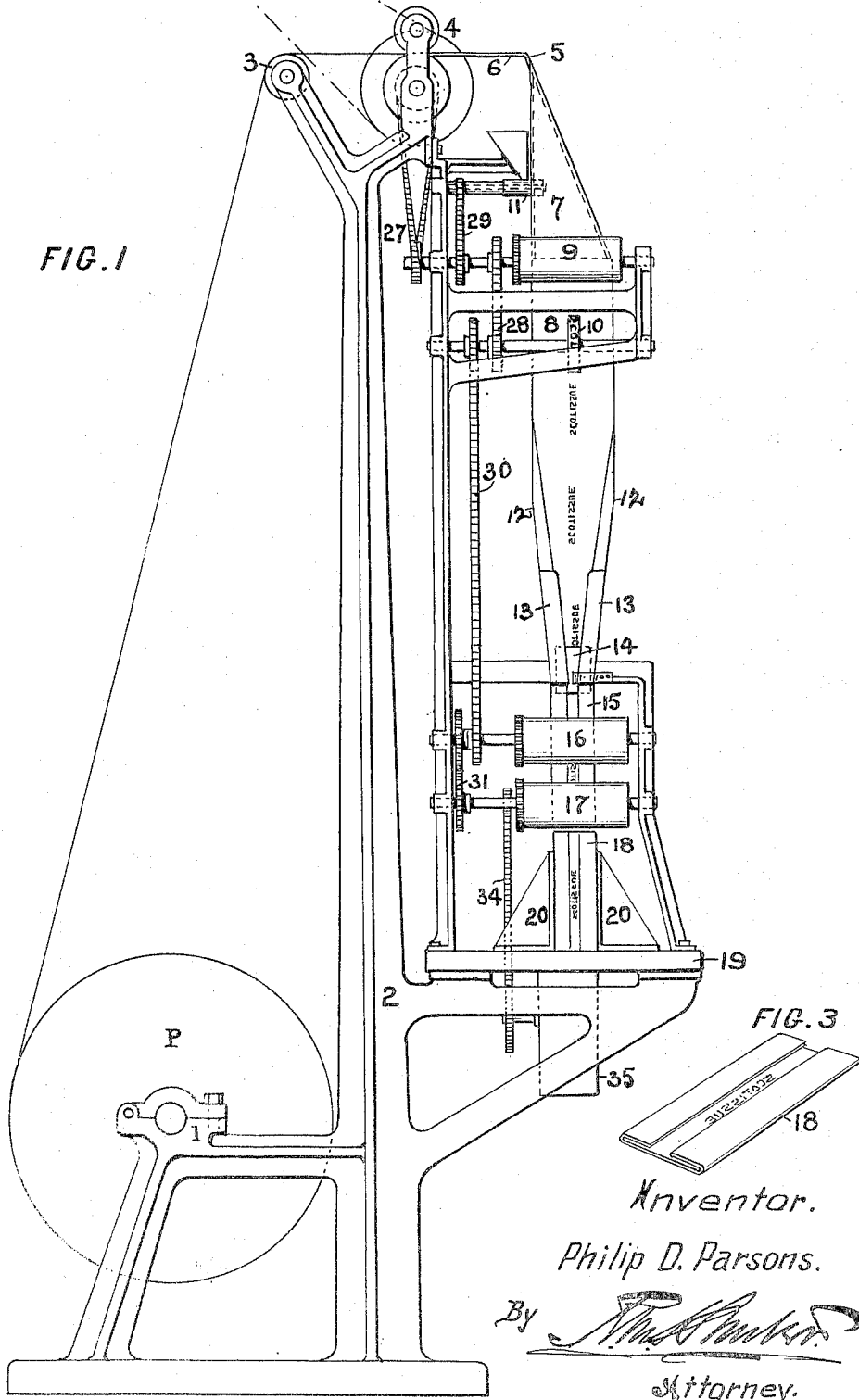

FIG. 1

FIG. 3

Inventor.

Philip D. Parsons.

By *Philip D. Parsons*

Attorney.

Sept. 15, 1925.

1,553,955

P. D. PARSONS

MACHINE FOR MAKING PAPER ARTICLES

Filed Aug. 20, 1923

2 Sheets-Sheet 2

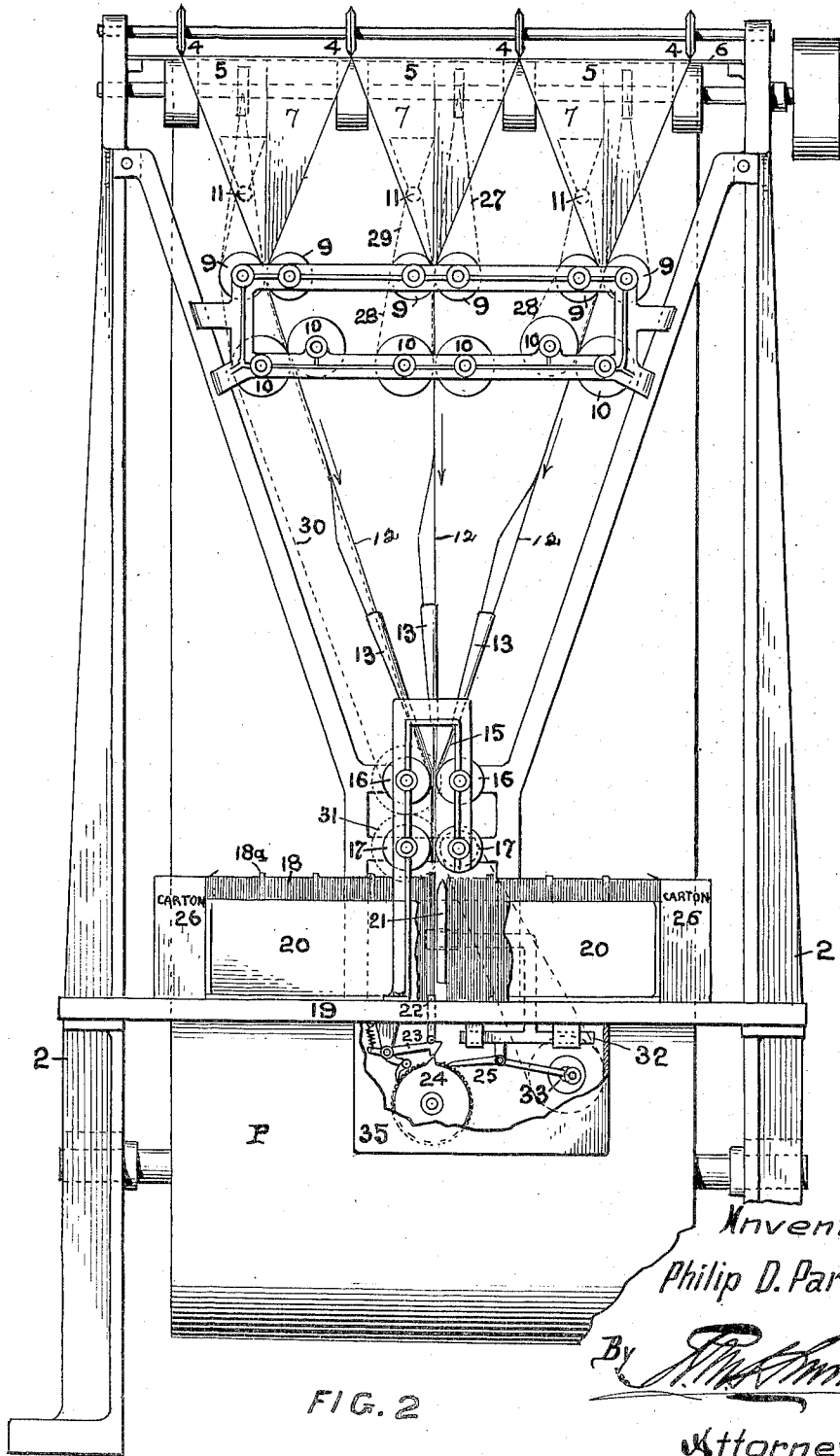

FIG. 2

Inventor.  
Philip D. Parsons.

By *[Signature]*

Attorney.

# UNITED STATES PATENT OFFICE.

PHILIP D. PARSONS, OF PHILADELPHIA, PENNSYLVANIA, ASSIGNOR TO SCOTT PAPER COMPANY, A CORPORATION OF PENNSYLVANIA.

## MACHINE FOR MAKING PAPER ARTICLES.

Application filed August 20, 1923. Serial No. 658,215.

*To all whom it may concern:*

Be it known that I, PHILIP D. PARSONS, a citizen of the United States, and resident of Philadelphia, county of Philadelphia, State of Pennsylvania, have invented an Improvement in Machines for Making Paper Articles, of which the following is a specification.

The object of my invention is for making articles from a roll of paper in an automatic manner and at the same time assembling them in quantities suitable for being packed in cartons, and more specifically, the object is to form paper towels from a roll of paper which is slit into relatively narrow web form, each web being simultaneously folded and severed into uniform lengths to constitute towels, the said towels then being assembled or packed in quantities suitable for separate packages, the entire operation being performed in an automatic manner.

As a further object of my invention, the paper towels are counted and fed in an automatic manner to cartons in which they are packed for shipment.

With the above and other objects in view, the nature of which will be more fully understood from the description hereinafter, the invention consists in the novel construction of machines for making paper articles, as hereinafter more fully described and defined in the claims.

Referring to the drawings: Fig. 1 is a side elevation of a machine embodying my improvements; Fig. 2 is a front elevation of the same; and Fig. 3 is a perspective view of one of the towels as made by the machine.

2 is the main frame of the machine and has at its rear a suitable support 1 for a roll of paper from which the towels are to be formed. At the upper end of the frame is a guide roller 3 and slitting rollers 4, the latter to be driven in any suitable manner. From the slitting rollers, the paper strips 5 are fed over a table 6 and thence over a suitable metal V-shaped folder 7, by which the paper strips are respectively folded into two-ply webs, as at 8, said folded paper being creased or flattened by means of rollers

9 which also constitute feeding rolls by drawing upon the webs. The two-ply webs are then drawn forward between the embossing rollers 10 which are intended to emboss the middle of the web with the trademark or trade-name of the goods.

11 is an edge pasting roll of which there is one for each of the webs, said roll being adapted to apply a small line or row of dots of paste on the underside of one of the edges of the web while passing about the folder 7, so that when the feeding or pull rolls 9 draw upon the paper and press the two edges of the web together, it provides a union between said edges to maintain the toweling in the finished case as of a two-ply material, and to facilitate the subsequent folding of the web when it passes through the formers 12, the said formers comprising laterally curved frames 13 oppositely directed and extending over a stationary former plate 14 of a character well known. By means of these formers, the edges of the two-ply web 8 are folded over toward each other to provide flaps which, when resting upon the body, make the finished toweling practically four-ply, but which when opened may be used as a two-ply towel.

The four-ply folded and embossed towel web 15 is fed forward by the feed rolls 16 and thence between the cutter rolls 17. While I have more particularly described the operation in connection with one of the webs of paper provided by the slitting of the main roll web, it will be understood that in the particular machine shown, there will be simultaneously produced three towel webs in folded condition which are brought together in superposed relation and simultaneously pass between the feed and cutter rolls so that three severed towels are simultaneously dropped at one time. The successive folded towels 18 so formed are dropped downward, as indicated in Fig. 2, so as to rest upon a table 19 and between lateral guide plates 20, where they are stacked by means of a laterally reciprocating packer blade 21, which has a short reciprocation so as to receive the descending towels on

one side and push them in stacked relation to the left (looking at Fig. 2), and at which time another set of towels is dropped vertically downward to the other side of the packer blade, so that on its reciprocation in the opposite direction, it packs the last mentioned paper towels between the guide plates 20 to the right in Fig. 1. In this manner, with each reciprocation of the packer blade, there is packed one set of towels to the left and one set of towels to the right, and this action is continued during the operation of the machine. In this construction, the action of gravity upon the falling towels is utilized for delivering them into position to be packed and the reciprocating packer blade 21 is so timed in relation to the forming mechanism for making towels that a set of towels is automatically dropped, first, to one side of the packer blade, and then to the other side alternately. In this manner, the number of towels packed to the right and to the left are equal. The rotating cutters 17 may, if desired, be in the form of rolls and assist in the downward feeding of the towel webs.

As it is important to count the towels mechanically which are to go in any one carton, this is readily accomplished by the following mechanism. A narrow adjustable vertical bar 22 is provided in the floor 19 immediately under the descending towel, and hence below the feed and cutter rolls. When this bar is down, its upper edge is flush with the surface of the table, but when raised, it supports the towels slightly above the table so that their upper edges will project a short distance above the normal level of the packed towels, as is indicated at 18<sup>a</sup>. It will now be seen that if we assume that 149 towels had been packed closely together and then the next towel, to constitute the quantity 150, were supported by the vertical bar 22, the packing of it would cause it to extend slightly above the rest of the towels and would designate to the operator the proper number of towels to be put into the carton 26 which stands upright on the table with the open end directed toward the approaching packed towels passing along between the guides 20. The friction between the edges of the paper towel and the two side guide plates 20 will hold the marking towel in its elevated position after the descent of the bar 22, and the further packing of the successive towels, so that these raised towels as markers will proceed along between the guide plates and project above the main body of towels, as indicated in Fig. 2.

Any suitable means may be employed for timing the raising of the bar 22 and a convenient means is shown, the same comprising a lever 23 to which the bar is hinged and by which it may be raised and lowered, a cam wheel 24 which raises the lever 23

once for each revolution, said cam wheel having teeth thereon which are engaged by a reciprocating pawl 25, said pawl being reciprocated once for each three hundred towels which are made and delivered to the packing devices, the cam holding the bar 22 in an elevated position during the packing of one towel to the left and one towel to the right, and thereafter being intermittently rotated by the pawl until one hundred and forty-nine towels are packed to the left and one hundred and forty-nine towels packed to the right, when it again comes into operation to cause two towels to be packed in elevated positions, one to the left and the other to the right, and so on. The reciprocating pawl 25 is operated by a crank wheel 33 which is driven by a sprocket chain 32 from the shaft of the revolving cutter 17, so that the raising and lowering of the bar 22 is in timed relation with the number of towels severed. The reciprocating packer blade 21 may be carried by and moved with the reciprocating bar to which the pawl 25 is secured and which is directly reciprocated by the crank wheel 33, so that the packer is also reciprocated in timed relation with the towels produced and delivered to the packing table.

While I do not restrict myself to any particular driving mechanism for the various parts, the following means may be employed. The slitting rolls 4 may be driven by any suitable power and from the lower shaft of said slitting rolls, the pull rolls 9 may be driven by a belt or chain 27. The pasting roll 11 may be driven by a belt or chain 29 from the shaft of the pull roll 9. The pull rolls are geared together and are also geared to the embossing rolls 10, so that the latter embosses the web corresponding to each towel length. The shaft of the embossing rolls may be geared to the feed rolls by a sprocket chain 30, so that the latter operates in timed relation with the pull rolls and embossing rolls. The feed rolls 16 are geared together to run in unison and are also geared to the cutter rolls by gears 31, so that the cutters are in timed relation with the rest of the apparatus, and by means of the sprocket chain 32, the packing and counting means are operated in timed relation, as before stated.

While I have thus described the initial power being applied to the slitting rolls, it will be understood that it may be applied to the feed rolls, or any other of the rotating parts, as may be found most convenient.

The special merits of this machine reside in the fact that in a single machine, a plurality of towels may be simultaneously made from a single roll of paper, the several webs of toweling being brought together and simultaneously severed into the definite lengths required for the toweling. In the

particular machine shown, the main roll of paper is slit into three webs and each of these webs are folded and formed into toweling webs having the general construction shown in Fig. 3, and consequently three towels will be delivered from the cutter roll 17 with each revolution thereof. It is manifest that any desired number of toweling webs may be simultaneously produced from the same roll, consistent with the width of the roll and the width of the towel webs before folding. It will also be understood that my invention comprehends a machine of the character described, whether it is intended for making a single towel web or a plurality of such webs. Another special advantage is that the toweling webs descend in a more or less vertical direction and when the webs are severed into towel lengths by the cutters 17, they drop by gravity into proper position on the particular side of the reciprocating packer which is required for the proper assemblage of the towels, thereby providing an exceedingly simple and reliable machine for the purpose desired.

It will now be apparent that I have devised a novel and useful construction which embodies the features of advantage enumerated as desirable, and while I have in the present instance shown and described the preferred embodiment thereof which has been found in practice to give satisfactory and reliable results, it is to be understood that I do not restrict myself to the details, as the same are susceptible of modification in various particulars without departing from the spirit or scope of the invention.

Having now described my invention, what I claim as new and desire to secure by Letters Patent is:

1. In a machine for making paper articles, the combination of a support for a roll of paper with means for slitting the paper into a plurality of relatively narrow webs, separate folding devices for folding the several webs each into a two-ply web, second folding means for each of the webs for respectively folding the edges of the two-ply webs toward each other to form four-ply webs, feeding devices for simultaneously feeding the plurality of folded webs in superposed relation, severing devices for severing the superposed folded webs into definite lengths, a table for receiving the folded web lengths whereby they may be guided and packed to each side of their place of delivery, and a reciprocating packer blade for alternately packing the successive web lengths delivered by the severing devices first in one direction and then in the other direction.

2. The invention according to claim 1, wherein the folded webs of paper are caused to descend in a more or less vertical direc-

tion whereby gravity assists in the delivery of the severed web lengths upon the table in an upright position, and the packer blade is adapted to project between the folded paper lengths being packed whereby it is arranged between the severing devices and the table.

3. The invention according to claim 1, wherein there is further combined timing devices for insuring the reciprocations to the packer to correspond to the cutting actions of the severing devices.

4. The invention according to claim 1, wherein the means for feeding the folded webs of paper are arranged to cause them to descend in a more or less vertical direction so that gravity assists in the delivery of the severed web lengths upon the table in an upright position, and the packer blade is arranged between the severing devices and the table and projects between the folded paper lengths as they reach the table, and wherein there is further combined a vertically adjustable bar in the vicinity of the packer and immediately below the descending web lengths for supporting certain of them at a higher elevation than others so that when they are packed they will project above the adjacent web lengths.

5. The invention according to claim 1, wherein the feeding devices for folding the webs of paper are arranged for causing them to descend in a more or less vertical direction so that gravity assists in the delivery of the severed web lengths upon the table in an upright position, and the packer blade is arranged between the severing devices and the table and projects between the folded paper lengths as they reach the table, and wherein there is further combined a vertically adjustable bar extending up from the table in the vicinity of the packer and immediately below the descending web lengths for supporting certain of them at a higher elevation than others so that when they are packed they will project above the adjacent web lengths, and timing means for raising the vertically adjustable bar at definite times whereby there shall be packed between successive raised towels a predetermined number of towels which, with the raised towels, are to be placed in a package or carton.

6. The invention according to claim 1, wherein there is further combined paste applying devices for applying paste to one of the edges of each of the paper webs while being folded into the two-ply condition whereby the free edges of each folded web are more or less united.

7. The invention according to claim 1, wherein there is further combined embossing means intermediate of the folder for forming the web into a two-ply web and

the folding means for forming the two-ply into a four-ply web whereby the two-ply web may be embossed with the trade-name or other designating mark of the articles in the finished condition.

8. The invention according to claim 1, wherein there is further combined pull rolls immediately at the lower ends of each of the separate folding devices which fold the webs into two-ply form, and wherein further the second feeding devices comprise a pair of rolls arranged at a lower level and immediately below the second folding means for causing a plurality of relatively narrow webs to be simultaneously fed vertically downward through said folding means, and in which the severing devices are arranged immediately below the feeding rolls and between them and the packing means.

9. The invention according to claim 1, wherein there is further combined pull rolls immediately at the lower ends of each of the separate folding devices which fold the webs into two-ply form, and wherein further the second feeding devices comprise a pair of rolls arranged at a lower level and immediately below the second folding means for causing a plurality of relatively narrow webs to be simultaneously fed vertically downward through said folding means, and the severing devices are arranged immediately below the feeding rolls and between them and the packing means, and the mechanism comprising the second folding means for each of the webs are arranged at an angle to each other for guiding the webs from the pull rolls into superposed relation between the feed rolls.

10. In a machine of the character stated, the combination of a support for a roll of paper, means for slitting the paper into a plurality of relatively narrow webs, separate folding devices over which the paper web is drawn for folding the several single ply webs into multiply webs, means for guiding and feeding the multiply webs downwardly in superposed relation, a horizontal table, severing devices for severing the superposed multiply webs into short lengths whereby they may be fed downward upon the table, guiding means upon the table for receiving the several lengths of the webs in packed relation, a laterally reciprocating packer means for packing the web lengths into the receiving means, and

timing means between the packer means and the severing means whereby the packer means is brought into timed operation.

11. The invention according to claim 10, wherein there is further combined a vertical adjustable support arranged adjacent to the surface of the table and immediately below the severing devices, so as to receive the lower edge of the severed lengths of the web when desired to hold certain of the web lengths at a higher elevation than the other adjacent lengths being packed, and timing means for raising the supporting means at intervals whereby certain web lengths may be positioned at higher elevations than intermediate web lengths to indicate a given number of web lengths to constitute a package.

12. The invention according to claim 10, wherein there is further combined means for applying paste adjacent to one edge of the paper web when being folded into a two-ply web for holding the two edges of the two-ply web in proper alinement.

13. In a machine for making paper articles, the combination of a support for a roll of paper with means for slitting the paper into a plurality of relatively narrow webs, separate folding devices for folding the several webs each into a two-ply web, additional folding means for each of the webs for respectively folding the edges of the two-ply webs toward each other to form four-ply webs and arranged for simultaneously feeding the plurality of folded webs in superposed relation, steering devices for severing the superposed folded webs into definite lengths, a table for receiving the folded web lengths whereby they may be guided and packed laterally with respect to their place of delivery, and a reciprocating packer means for packing successive web lengths delivered by the severing devices.

14. The invention according to claim 13, wherein there is further combined embossing devices arranged between the first and second folding devices whereby the two-ply web is embossed before being folded into four-ply, the folding devices and the embossing devices being arranged in vertical relation.

In testimony of which invention, I hereto set my hand.

PHILIP D. PARSONS.