

W. SCOTT.  
SIPHON WATER CLOSET.

No. 572,575.

Patented Dec. 8, 1896.

Fig. 1.

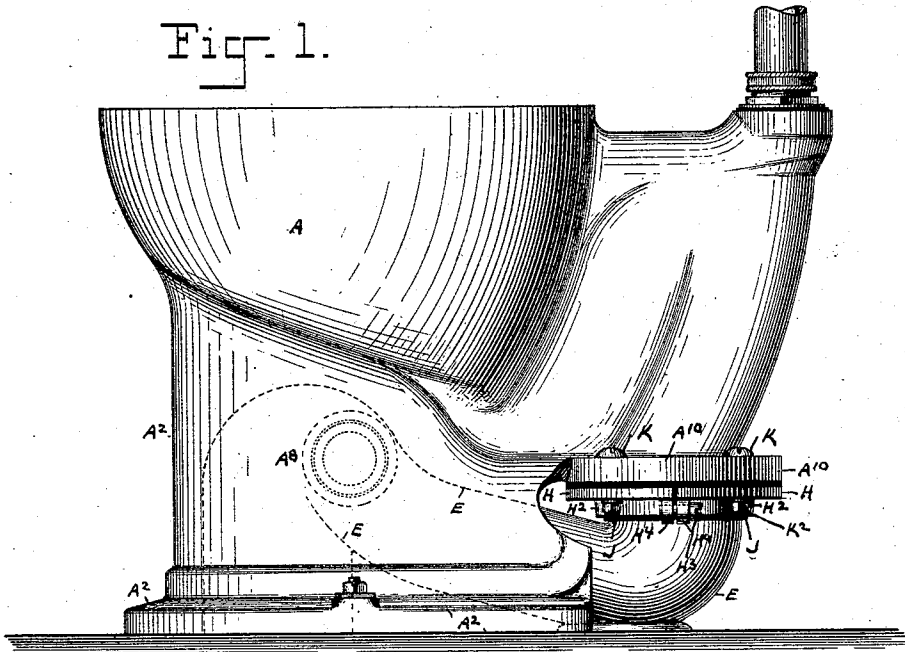
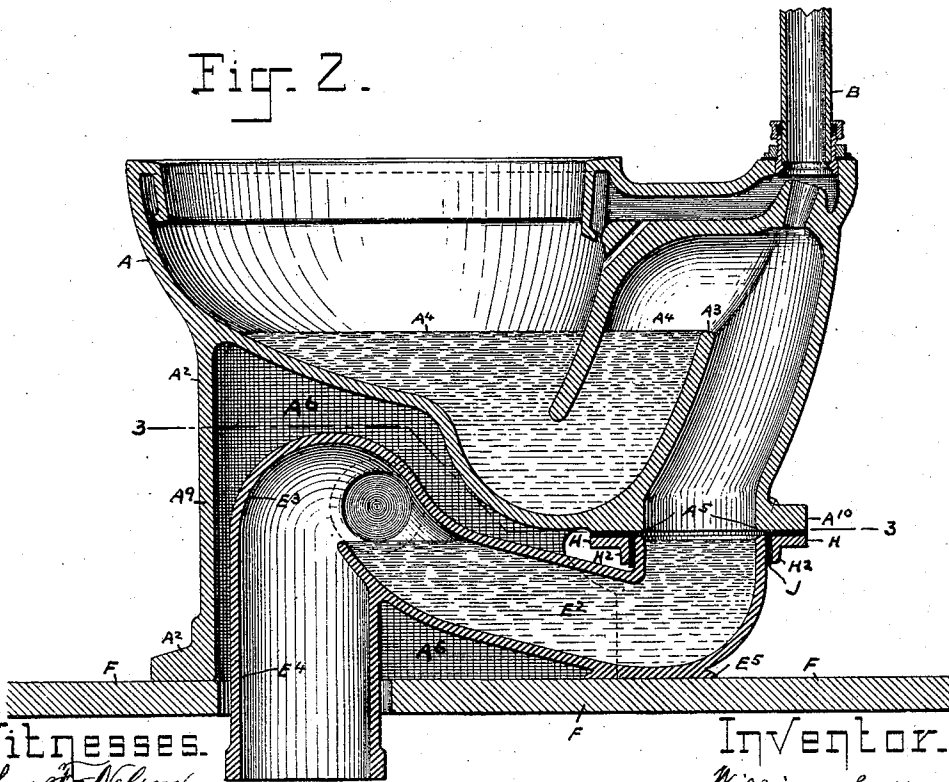

Fig. 2.



Witnesses.

*John D. Nelson.*  
*Samuel Griffin*

Inventor.

*William Scott*  
by his Attorneys  
*Brown Bros.*

W. SCOTT.  
SIPHON WATER CLOSET.

No. 572,575.

Patented Dec. 8, 1896.

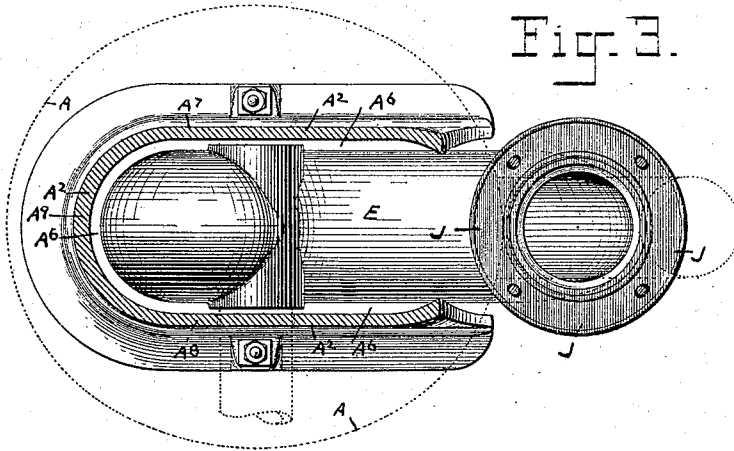

Fig. 3.

Fig. 4.

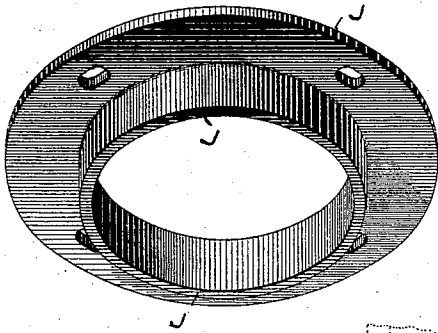

Fig. 5.

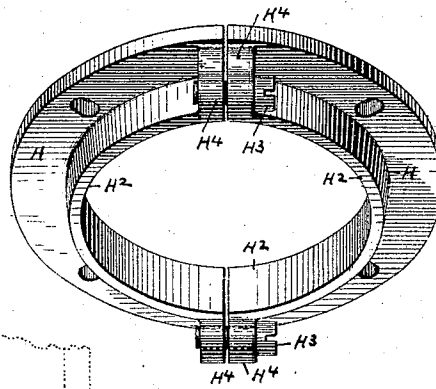
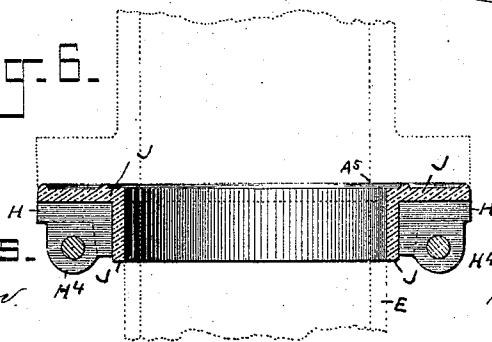

Fig. 6.



Witnesses.

*John F. Nelson.*  
*Samuel Griffin*

Inventor.

*William Scott*  
*by his Attorneys*  
*Brown Bros.*

(No Model.)

3 Sheets—Sheet 3.

W. SCOTT.  
SIPHON WATER CLOSET.

No. 572,575.

Patented Dec. 8, 1896.

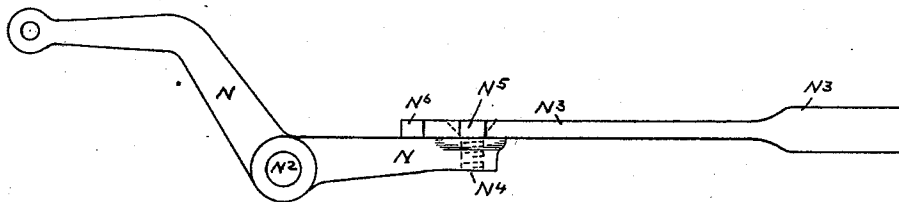
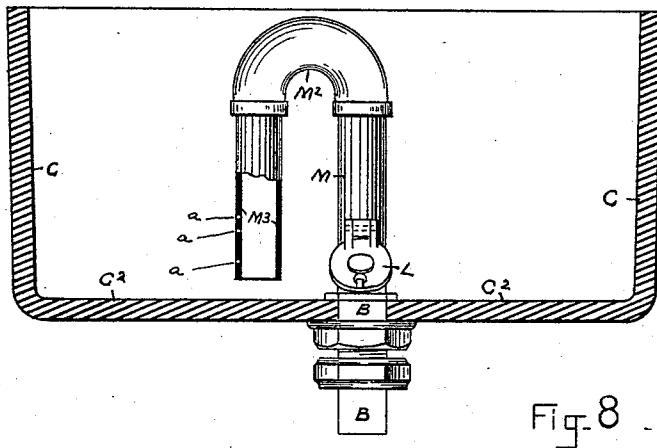
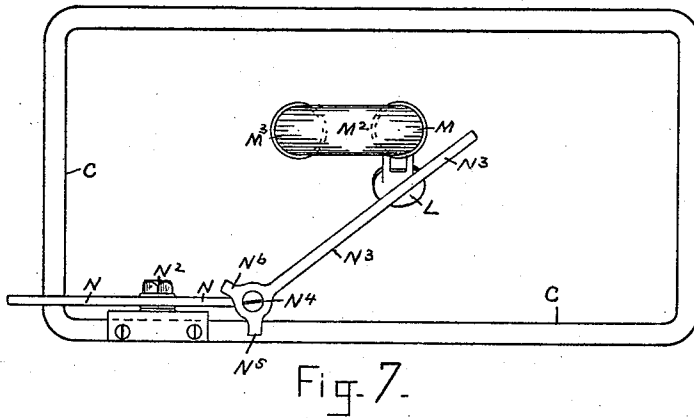

WITNESSES:  
*Frances M. Brown.*  
*Marion E. Brown.*

Fig. 9.

INVENTOR:  
*William Scott*  
*by his Attorneys*  
*Brown Bros.*

# UNITED STATES PATENT OFFICE.

WILLIAM SCOTT, OF MEDFORD, MASSACHUSETTS, ASSIGNOR TO THE DALTON-INGERSOLL COMPANY, OF MASSACHUSETTS.

## SIPHON WATER-CLOSET.

SPECIFICATION forming part of Letters Patent No. 572,575, dated December 8, 1896.

Application filed October 21, 1890. Serial No. 368,859. (No model.)

*To all whom it may concern:*

Be it known that I, WILLIAM SCOTT, a citizen of the United States of America, and a resident of the town of Medford, in the county of Middlesex and State of Massachusetts, have invented certain new and useful Improvements in Siphon Water-Closets, of which the following is a full, clear, and exact description.

This invention in siphon water-closets, in substance, consists, first, of an earthenware bowl having its pedestal chambered and otherwise adapted to receive and practically to cover and inclose a metal pipe and to allow of its proper connection to the bowl at its discharge-opening and to the waste-pipe; second, of means to connect a metal pipe to an earthenware bowl at the discharge-opening of the latter; third, of an improved lever by which to open the tank-valve to discharge the water of the tank, and, fourth, of an improvement in the short leg of the siphon-pipe of the tank, all substantially as hereinafter described.

In the drawings forming part of this specification, Figure 1 is a side elevation of the siphon water-closet. Fig. 2 is a central vertical section from front to rear of the closet, Fig. 1. Fig. 3 is a horizontal section, line 3 3, Fig. 2. Fig. 4 is a perspective view, enlarged, of the packing-ring. Fig. 5 is a perspective view, enlarged, of the split ring. Fig. 6 is a central vertical section, enlarged, of the split and packing rings placed together. Fig. 7 is a plan view of the tank, its siphon-pipe, valve to said pipe, and lever to open said valve. Fig. 8 is a longitudinal vertical section of the tank and in part a side view of the siphon-pipe and a vertical section of the lower and open end of short leg of said pipe. Fig. 9 is a side view of the operating-lever for valve of tank.

In the drawings, A represents the upper or bowl portion, and A<sup>2</sup> is the lower or pedestal portion, of an earthenware or other such like bowl. The bowl A is formed, as usual, to have water entered into it from a supply-pipe B, that leads from a water-tank C, and also to have water discharged from it passing through a water-passage A<sup>3</sup> in continuation and making part of the water-trap of the bowl and out at an opening A<sup>5</sup>, all substantially as well known.

As this invention is particularly shown, the discharge-opening A<sup>5</sup> of bowl is connected to one end of a water-trap E<sup>2</sup>, which makes part of a cast-iron or other suitable pipe E, and has its opposite end continued upwardly and rounded at E<sup>3</sup> and thence downwardly at E<sup>4</sup>, of suitable length to lead through and to project below the floor F of the room on which the bowl is placed, and below the floor to be entered into the under side of a shouldered hub of a waste-pipe and therein packed tightly in any suitable and well-known manner.

The metal pipe E, as shown, extends from rear to front of and underneath the bowl A, and it lies within a chamber A<sup>6</sup> of the pedestal A<sup>2</sup>. This pedestal-chamber A<sup>6</sup>, as shown, has side walls A<sup>7</sup> A<sup>8</sup> and a front wall A<sup>9</sup>, and these walls are continuous and together make the pedestal, and said metal pipe E on its upper and opposite vertical side and front portions is inclosed in said chamber, and the pipe preferably has a base E<sup>5</sup> for its better rest on the floor F. At the rear portion of the bowl is a horizontal projecting flange A<sup>10</sup> at and about the discharge-opening A<sup>5</sup> of the bowl. The rear end of the metal pipe E is presented toward the underside or face of the bowl-flange A<sup>10</sup>, and it is connected to and fastened against said face of said flange, and their joint is packed all by means consisting, in substance, first, of a metal or such like rigid flat ring H, having a downward-projecting flange H<sup>2</sup> around its inner edge and split diametrically and vertically into sections, joined transversely by headed screw-bolts H<sup>3</sup>, passing loosely through one and screwing into the other of adjacent vertical earpieces H<sup>4</sup> of the ring; second, of an india-rubber or other such like compressible gasket or ring J of a shape corresponding to said metal ring, but preferably not split, and adapted by its flange to fit within the flange and lie upon the outer face of the metal ring, and, third, of headed screw-bolts K, entered through suitable holes located at intervals of said metal ring and of said compressible gasket and bowl-flange and having screw-nuts K<sup>2</sup> screwed upon them.

In applying the described means of connection for a metal pipe E and a bowl A the ring H (its sections being loosely held together by the screw-bolts H<sup>3</sup>) and the gasket

J, placed in the ring, as described, are together placed around the outside of the pipe E at or near its end which is open and toward the bowl discharge-opening A<sup>5</sup> and then  
 5 lifted to make close seat of gasket against seating-face therefor of bowl-flange, on which the ring by turning up the screw-bolts H<sup>3</sup> of its sections is closed about the gasket, closing it in turn tightly about and on the pipe,  
 10 and then by turning up the screw-nuts K<sup>2</sup> of the screw-bolts K, located in the bowl-flange, the ring and gasket are made fast to the bowl-flange, tightly closing the gasket there-against and as a whole securing a tight and  
 15 close connection of bowl and pipe. In attaching bowl and pipe E, as stated plainly, care is to be taken that a tight and close joint is made of gasket, both with pipe and bowl-flange.

20 The connection of bowl and metal pipe described is advantageous in that the ring and its gasket can be adjusted lengthwise on the pipe to accommodate them to varying relative heights of the bowl-flange and the open  
 25 end of metal pipe, all so liable to occur because of variations in the height and in the form of the jointing-face of the bowl-flange, the results of molding the bowl, and otherwise, all as well known. Again, a chambering  
 30 of the pedestal and a seat-facing of an earthenware bowl, all substantially as described, secures not only a practical inclosure of a metal pipe E, but also permits connection of bowl and said pipe to be readily made  
 35 and without either disfigurement of the bowl or of its pedestal, or of exposure to any appreciable degree of the pipe.

The bowl described, in combination with a metal pipe E, having a water-trap E<sup>2</sup>, as particularly explained, secures a double trapping of the discharge-passage of the bowl and a column of air between said two traps, but this of itself is not new.

45 So far as has been in detail explained it is obvious that the water-trap of the pipe E may be dispensed with; again, that the direction of the run of the pipe E as to the bowl-pedestal and the chambering of the pedestal may be changed to accommodate varying positions  
 50 of the discharge-opening of the bowl and of the waste-pipe to be connected by the pipe E; again, that the seating and jointing face of the bowl for connection with the pipe E may be varied in position to suit a different position from that shown of the open end of the  
 55 pipe E, and, again, that other means of connection of the pipe E and bowl may be used, and all without departing, in substance, from the features of this invention, to which such  
 60 obvious modifications may and do pertain.

L is an ordinary hinged valve located in the tank and arranged, as usual, to be opened for passage through the pipe B of water from the tank to the bowl.

65 M is an upward extension of the pipe B from valve L, and this extension at its upper end

M<sup>2</sup> is rounded over and thence has a downward extension M<sup>3</sup>, ending near the floor C<sup>2</sup> of the tank, and all so that the whole makes a siphon-pipe for a discharge by its siphon  
 70 action of the contents of the tank, first having set the water in motion through pipe B by an opening and then closing of valve L of said pipe. The downward extension M<sup>3</sup> is the short leg, and the remainder M<sup>2</sup> M and its  
 75 continuation B is the long leg, of the siphon-pipe, and heretofore as siphon-pipes in siphon water-closets have been arranged and constructed their siphonic action is and can only be broken either partially or wholly by the  
 80 entrance of air at the open end of the short leg of the siphon-pipe, thus causing oftentimes (and, in fact, most generally) such a flow of water through the bowl that at the end of the water-flow no substantial amount of  
 85 water can or will be left standing in the trap of the bowl.

This invention aims to and practice and experience have shown that it avoids the objection stated, and to that end and in this relation the devices of the invention consist of  
 90 a series of perforations *a a a*, shown as three in number, but which may be more or less than three, three, however, being found practical. These perforations are located each in  
 95 a different horizontal plane of one side of the short leg of the siphon-pipe. Each perforation is small and the whole series taken together are of a considerably less superficial area than the open end of said short leg.  
 100 The perforations separately and together admit air to the siphon-pipe when the water of the tank has been drawn off from the tank to and below their level, and thereby is secured a gradual reduction or breaking, or, as it  
 105 were, a tempering of the force of the siphonic discharge before it is fully arrested, and all so that not only is the desired discharge in quantity of water from the tank secured, but also standing water in the bowl to the height  
 110 desired, the latter result being made most sure and reliable.

N is a lever which is arranged vertically edgewise and is hung intermediately of its length on a horizontal fulcrum-pin N<sup>2</sup> of one  
 115 of the side walls of the tank C. One portion of this lever lies within and along the inner face of said side wall of the tank and the other portion projects over one end of the tank, and there a chain or such like (not shown) is to  
 120 be attached for operating it.

N<sup>3</sup> is an arm that at one end is fastened by a set-screw N<sup>4</sup> rigidly to the portion of the lever which lies within the tank and at its other end is over the tank-valve, to which it  
 125 is connected by chain or such like. (Not shown.) This arm N<sup>3</sup>, near its point of attachment to lever N, has two radial carpieces N<sup>5</sup> N<sup>6</sup>, each in position to serve, according as the lever is fulcrumed at one or the other end  
 130 of the tank, as a rest and stop, by contact with the upper edge of the tank, to the down-

ward movement of the portion of the lever to which the tank-valve is to be attached, as stated.

Having thus described my invention, what I claim, and desire to secure by Letters Patent, is—

1. A flushing closet-bowl, in one piece of earthenware, and containing a trap, one leg of which is a passage leading upward from the lower portion of the chamber of the bowl and the other and discharging-leg a passage in continuation of said bowl-passage and at the rear of the bowl, a passage in downward continuation of said discharging trap-leg, a flange at and projecting laterally from the discharging end of said discharging trap-leg and a pedestal situated below and continuous along the front and each side of the bowl and shaped to form a chamber therewithin, which is open at and about said bowl-flange, in combination with a metal trap, at its receiving-leg joined to said bowl-flange and therefrom lying and inclosed within said pedestal-chamber substantially as described, for the purpose specified.

2. The combination with the discharge of an earthenware closet-bowl and a metal pipe in continuation of the discharge of said bowl, of appliances to join said pipe to said bowl, consisting of a flange projecting laterally about the discharge of the bowl, a metal ring, split radially, and shaped and adapted to surround said pipe and the under side of said bowl-flange, a packing-ring in one piece adapted to fit within and upon the face of said split ring at the under side of said bowl-flange, and means adapted to be applied to said split ring to close it above said metal pipe and to fasten it with the packing to said bowl-flange substantially as described, for the purposes specified.

3. A lever for operating valves of tanks of

water-closets, made in parts, one fulcrumed on the tank and another detachably attached to said fulcrumed part and having earpieces N<sup>5</sup>, N<sup>6</sup>, substantially as described, for the purposes specified.

4. In a water-closet apparatus, the combination with a metal trap, of a bowl, outlet, and hollow pedestal, all made from a single piece of earthenware, the pedestal inclosing the said trap and constructed to form a horizontal outwardly-extending flange at its junction with the outlet, and means for securing together said flange and trap, substantially as described.

5. In a water-closet apparatus, the combination with a metal trap, of a bowl, outlet, and hollow pedestal, all made from a single piece of earthenware, the pedestal having sides extending down to a common base-level so as to incase the trap, the outlet having a perforated outwardly-extending flange adjoining the pedestal, a packing-ring, bolts or screws projecting upwardly through the flange and packing-ring, and exteriorly-arranged nuts engaging with the protruding threaded ends of the bolts or screws, substantially as described.

6. A water-closet bowl, outlet, and hollow pedestal, all made from a single piece of earthenware, the walls of the pedestal all extending down to a common base-level, and the pedestal and outlet being constructed to form at their junction a horizontal outwardly-extending perforated flange, substantially as and for the purpose set forth.

In testimony whereof I have hereunto set my hand in the presence of two subscribing witnesses.

WILLIAM SCOTT.

Witnesses:

ALBERT W. BROWN,  
GEO. H. CUSHMAN.