



- (51) International Patent Classification: *G01N 21/65* (2006.01) *G01N 21/33* (2006.01)
- (21) International Application Number: PCT/US2012/037679
- (22) International Filing Date: 12 May 2012 (12.05.2012)
- (25) Filing Language: English
- (26) Publication Language: English
- (30) Priority Data:
 

61/485,473	12 May 2011 (12.05.2011)	US
61/610,359	13 March 2012 (13.03.2012)	US
- (71) Applicant (for all designated States except US): **ALAKAI DEFENSE SYSTEMS, INC.** [US/US]; 7935 114th Avenue N., Suite 1100, Largo, FL 33773 (US).
- (72) Inventors; and
- (75) Inventors/Applicants (for US only): **POHL, Kenneth, Randall** [US/US]; 7935 114th Avenue N., Suite 1100, Largo, FL 33773 (US). **FORD, Alan, Ray** [US/US]; 7935 114th Avenue N., Suite 1100, Largo, FL 33773 (US). **WATERBURY, Robert, Douglas** [US/US]; 7935 114th Avenue N., Suite 1100, Largo, FL 33773 (US). **VUNCK, Darius** [US/US]; 7935 114th Avenue N., Suite 1100, Largo, FL 33773 (US). **DOTTERY, Edwin, L.** [US/US]; 7935 114th Avenue N., Suite 1100, Largo, FL 33773 (US).
- (74) Agent: **PARADIES, Christopher**; Fowler White Boggs P.A., 501 East Kennedy Blvd., Suite 1700, Tampa, FL 33602 (US).
- (81) Designated States (unless otherwise indicated, for every kind of national protection available): AE, AG, AL, AM, AO, AT, AU, AZ, BA, BB, BG, BH, BR, BW, BY, BZ, CA, CH, CL, CN, CO, CR, CU, CZ, DE, DK, DM, DO, DZ, EC, EE, EG, ES, FI, GB, GD, GE, GH, GM, GT, HN, HR, HU, ID, IL, IN, IS, JP, KE, KG, KM, KN, KP, KR, KZ, LA, LC, LK, LR, LS, LT, LU, LY, MA, MD, ME, MG, MK, MN, MW, MX, MY, MZ, NA, NG, NI, NO, NZ, OM, PE, PG, PH, PL, PT, QA, RO, RS, RU, RW, SC, SD, SE, SG, SK, SL, SM, ST, SV, SY, TH, TJ, TM, TN, TR, TT, TZ, UA, UG, US, UZ, VC, VN, ZA, ZM, ZW.
- (84) Designated States (unless otherwise indicated, for every kind of regional protection available): ARIPO (BW, GH,

[Continued on next page]

(54) Title: OPTICAL HAZARD AVOIDANCE DEVICE AND METHOD

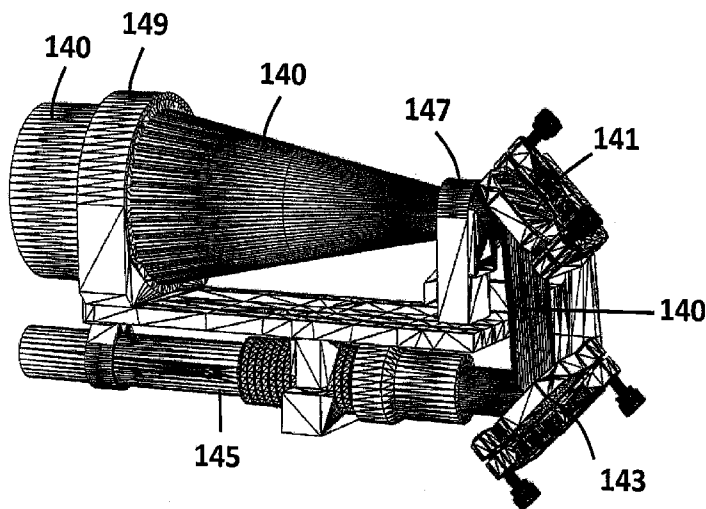

FIG. 15

(57) Abstract: A source providing a nominal hazard that could cause ocular damage within a given range from the source, such as a first laser, is mitigated by an optical hazard avoidance device, such as a second laser, that stimulates voluntary, involuntary, or both voluntary and involuntary responses, either physiological or behavioral or both physiological and behavioral, within one or more hazard zones, such as by inducing gaze aversion within the viewer. The optical hazard avoidance device may include one or more interlocking devices or other devices for interrupting the firing of the source. For example, a visible laser beam induces gaze aversion, pupil contraction or a combination of gaze aversion and pupil contraction, reducing the dose rate or exposure of the ocular tissue to damaging radiation from a primary source, which may be combined with a motion sensor or human face detection device. In one example, the primary source is a UV Raman detector and the visible laser beam is selected to induce gaze aversion.





GM, KE, LR, LS, MW, MZ, NA, RW, SD, SL, SZ, TZ, UG, ZM, ZW), Eurasian (AM, AZ, BY, KG, KZ, RU, TJ, TM), European (AL, AT, BE, BG, CH, CY, CZ, DE, DK, EE, ES, FI, FR, GB, GR, HR, HU, IE, IS, IT, LT, LU, LV, MC, MK, MT, NL, NO, PL, PT, RO, RS, SE, SI, SK, SM, TR), OAPI (BF, BJ, CF, CG, CI, CM, GA, GN, GQ, GW, ML, MR, NE, SN, TD, TG).

**Published:**

- *with international search report (Art. 21(3))*
- *before the expiration of the time limit for amending the claims and to be republished in the event of receipt of amendments (Rule 48.2(h))*

## OPTICAL HAZARD AVOIDANCE DEVICE AND METHOD

### Field of the Invention

[0001] The field relates to devices for prevention or mitigation of optical damage to the cornea and retina by exposure to an optical hazard such as a beam from a laser.

### Background

[0002] ANSI Z136.1-2007 discloses known and accepted methods for preventing and mitigating hazards caused by lasers to vision. The cornea and retina are especially vulnerable to damage in humans and animals from laser sources having frequencies with visible and not visible wavelength. In some instance, laser beams that are not visible are more dangerous than those in the visible range, the person or animal does not see the beam and cannot know to react to avoid damage. Visible beams of sufficient intensity can still cause damage if a person does not avert the eyes or blink, but a person may be subject to sustained exposure to an invisible beam that can cause damage over a longer period of time if the person stares into the beam with no knowledge of its existence.

[0003] In practice, engineering and safety controls prevent operation of an optical hazard or block the optical hazard from causing damage outside of a confined area or within a hazardous range. Even highly coherent laser beams diverge and attenuate over distances. Beams and sources with greater divergence attenuate that much more rapidly with distance from the source. Therefore, in some cases, an optical hazard may be limited to a comparatively short range, beyond which, even lengthy exposures will not cause any lasting damage.

[0004] Administrative and procedural controls are good practices generally adopted when use of potentially hazardous conditions could be caused by an optical hazard of some type. These practices may mitigate exposure when engineering and safety controls fail, for example, or when engineering and safety controls are impractical, such as in field use of lasers for targeting, detection, distance measuring, communications, manufacturing, such as curing of epoxy, and other industrial processes and the like. These can include the use of special eyewear, films and filters and procedures for clearing a down range area of personnel prior to the use of optical hazards.

[0005] U.S. Pat. No. 7,500,763; 7,180,426; and 6,190,022 use a light source comprising a laser and/or LED's, with or without a range finder, to incapacitate individuals within range of the laser and/or LED's. These systems have a range finder or take other precautions to avoid a threshold exposure that would exceed a permissible exposure threshold that could cause permanent damage. While these devices are designed to merely temporarily disorient and incapacitate, use of these potentially hazardous optical devices is controlled and limited and may not be allowed due to the possibility that such devices might cause temporary or permanent ocular damage, beyond the desired effect of mere temporary disorientation and incapacity. Rangefinders and the like are not 100% effective in detecting humans and animals within a danger zone, and approval for use of such devices is likely to be limited to devices that are limited to very modest effects, such as the light from flash bulbs and the like.

[0006] U.S. Pat. Appl. 11/215,777 discloses a system for the purpose of preventing ocular damage from a laser using a sensor for sensing the position of a hand and a control for controlling the operation of the laser based on that position. This has the advantage of being able to prevent operation of the laser if the position of the hand is not in a safe location, but it has the disadvantage of being limited to a known user. The system is not capable of tracking the locations of unknown humans and animals that could stray into an optical hazard zone.

[0007] U.S. Pat. No. 6,270,467 discloses a system, device and method for preventing computer vision syndrome (CVS) using a means of reminding a particular computer user to blink, periodically, preventing excessive drying of the eyes.

[0008] U.S. Pat. No. 7,695,141 discloses a system using a stimulus light source projected to the retina of an ocular fundus under examination to stimulate the retina in a localized fashion to generate a bioelectrical signal from the retina, assuring a reliable local electroretinogram. The device is limited to an exam of a particular patient and cannot cause an avoidance response in the patient or others.

[0009] U.S. Pat. No. 4,299,464 discloses a method and device for utilizing a light source to stimulate an optical response to reduce or prevent "red eye" in flash photography. U.S. Pat. No. 4,285,588 discloses a method and device for reducing the incidence of eye closure during flash photography utilizing a pre-flash to cause the subject or subjects to blink prior to the

opening of the shutter and a second flash. While this disclosure teaches the stimulation of an involuntary response, the pre-flash results in exposure of the eye to a flash rather than avoidance of a flash.

[00010] None of the known methods for preventing or mitigating damage from optical hazards uses stimulated physiological responses induced by a second laser or other optical hazard avoidance device in order to avoid or mitigate optical damage within a hazard zone of a first laser.

### **Summary**

[00011] An optical hazard avoidance device forces a physiologic response in a person or animal (“viewer”) that mitigates the ocular exposure of the viewer to a particular optical hazard that would otherwise possibly cause temporary or permanent ocular damage, such as corneal or retinal damage. The device stimulates an involuntary and/or voluntary avoidance response.

[00012] In one example, a source of light that could cause ocular damage within a given range from the source of light, such as a first laser, is accompanied by an optical hazard avoidance device, such as a second laser, that stimulates a voluntary, involuntary, or both a voluntary and an involuntary responses, either physiological or behavioral or both physiological and behavioral, within one or more hazard zones, such as by inducing gaze aversion within the viewer. Physiological responses are reflexes, often involuntary, of a single subject that mitigate or avoid damage, such as blinking, flinching, pupil contraction, closing of the eyes, averting a gaze, ducking and the like. Behavioral responses are individual or group responses that mitigate or avoid damage by limiting exposure to potential hazards by changing the behavior of an individual or group, such as by moving farther away, shielding of eyes, looking away without looking back, dispersing of a crowd and the like.

[00013] In one example, an optical hazard, such as a powerful source of light that is not visible, is combined with an optical hazard avoidance device comprising a visible light source, such as a light emitting diode and/or laser light source. For example, both a visible LED light source and a visible laser light source may be combined in an optical hazard avoidance

device. The LED light source may stimulate a physiological or behavioral response within a short distance from the optical hazard. The visible laser source may stimulate a physiological response at longer ranges, out to at least the hazard zone of the optical hazard, for example. In one example, the visible LED light source causes an avoidance response within zero to ten meters from the optical hazard, while the visible laser light source causes an aversion of gaze or a blink response at a much greater distance. In one method, the LED light source is operated to warn any person or animal within a short range of the optical hazard to shield its eyes or to avert its gaze or to exhibit other physiological or behavioral responses, and the visible laser light source commences prior to the operation of an optical hazard for a short duration such that any viewer within a hazard zone blinks or averts the viewer's eyes prior to and during the illumination of a down range target or other object by the optical hazard, such as a laser range finder or laser used in a detection system. This can be repeated for each pulse of a pulsed optical hazard, if necessary. For a continuous operation of an optical hazard, the optical hazard avoidance device may be operated continuously or in a pulsed mode, stimulating rapid blinking and/or averting a gaze of any viewer down range within the hazard zone. The optical hazard avoidance device at least puts the viewer on notice of an optical hazard, which would not be apparent if the optical hazard comprising a source of light that is not visible, such as a laser operating in the infrared, ultraviolet or microwave ranges, for example.

[00014] The optical hazard avoidance device may be a system that stimulates either or both of a voluntary or involuntary response without exposing the subject to a dangerous level of light, itself. The system may include other components such as multiple light sources, range finders and lock outs to avoid use of the device if a person or animal is located within a certain range from the optical hazard avoidance device or to lock out the optical hazard until the person or animal moves away from the optical hazard, for example.

[00015] In one example, an optical hazard avoidance device ("OHAD") flashes in a pulse of intense, visible light that causes a viewer of the OHAD to involuntarily blink. The pulse may be repeated or may extend for an entire duration of exposure from an optical hazard, such as laser beam. A method of using the OHAD in conjunction with a high power laser light source may permit a higher power beam to be would be permitted otherwise. The high power laser light source could exceed the safety threshold for duration and intensity of the laser beam,

because any person down range would be protected by the OHAD stimulating an avoidance response during the entire time that the high power laser light source is operating.

[00016] In alternatives, additional or other types of energy may be emitted from the OHAD, such as sonic or thermal energy. For example, a directed sound amplifier could cause a sudden loud noise to be directed down range along the line of sight of an optical hazard, stimulating a flinching, ducking or other avoidance response. In addition, microwaves may induce a burning sensation on exposed skin that can stimulate a physiological or behavioral avoidance response. In one example, a combination of these and light are used to stimulate an avoidance response.

[00017] ANSI Z136.1-2007 defines the blink reflex as the involuntary closure of the eyes as a result of stimulation by an external event such as ... a bright flash," which is adopted herein as the definition of the blink reflex. In ANSI Z136.1-2007, "the ocular aversion response for a bright flash of light is assumed to limit the exposure of a specific retinal area to 0.25 seconds or less," because the standard assumes that the optical hazard and the bright flash of light are caused by one and the same light source. Thus, a bright flash of light that would involuntarily stimulate the blink reflex is limited to a threshold intensity level along its path not greater than a level that would cause ocular damage in 0.25 seconds or longer. A method of optical hazard avoidance using an optical hazard avoidance device can allow the intensity of a laser light source greater than that allowed in the standard, because the method uses the device to stimulate a blink reflex (and potentially one or more additional physiological responses) up to 0.25 seconds before the operation of the laser light source. In one example, the laser light source is a pulsed laser of a short duration, preventing any exposure of a person down range due to the involuntary blink response stimulated by using the optical hazard avoidance device in the method of optical hazard avoidance. In one example, the optical hazard avoidance device is a flash that starts 0.25 seconds before operation of a hazardous laser light source, and the pulse of the flash of the device continues until the pulse of the hazardous laser light source is completed. In this way, the optical hazard avoidance device prevents the viewing of the pulsed, hazardous light source by a single blink reflex of any person down range. In another method, the optical hazard avoidance device is a rapidly pulsed light source that flashes on and off during the

operation of a hazardous laser light source, reducing the exposure of any person down range by causing repeated, involuntary blink reflexes and an aversion response.

### **Brief Description of the Drawings**

[00018] Figure 1 illustrates an example of a system including an optical hazard avoidance device.

[00019] Figure 2 illustrates a graph of an example of OHAD timing for stimulating a blink response.

[00020] Figure 3 illustrates a graph of another example of OHAD timing for stimulating a blink response.

[00021] Figure 4 schematically illustrates an example of a system, such as a detector, including an OHAD.

[00022] Figure 5 illustrates an intensity diagram of a second optical source of an OHAD superimposed on an intensity diagram of a first optical source of a primary optical hazard.

[00023] Figure 6 schematically illustrates an example of a detector including an OHAD.

[00024] Figure 7 schematically illustrates an alternative example of a detector including an OHAD.

[00025] Figures 8-8C schematically illustrate the example in Figure 6 and examples of beam width intensities at A', B' and C'.

[00026] Figure 9 (A)-(D) illustrate examples of beam intensities and width of a visible beam of an OHAD at (A) 0 meters; (B) 10 meters and (C) 30 meters superimposed on a target showing (D) 3" and 4" circles.

[00027] Figure 10 illustrates an example of aversion optical exposure intensity versus distance (range) in meters including certain levels defined by the ANSI Z136.6 standard.

[00028] Figure 11 illustrates an OHAD range selected by referring to ANSI Z136.1 and 136.6 (2007) Sensitive Level.

[00029] Figure 12 illustrates an alternative example of an OHAD range selected by referring to ANSI Z136.6 Critical Level.

[00030] Figure 13 illustrates a perspective shaded view of one example of an OHAD.

[00031] Figure 14 illustrates a side plan view of the OHAD example in Figure 13.

[00032] Figure 15 illustrates another perspective view of the OHAD example in Figure 13.

[00033] Figure 16 illustrates an example of a graph of maximum permissible exposure per pulse for a pulsed laser with and without an OHAD inducing gaze aversion response.

[00034] Figure 17 illustrates an example of a graph of maximum permissible exposure per pulse for a pulsed laser with and without an OHAD inducing gaze aversion response.

[00035] Figure 18 illustrates an example of a graph showing intensity of a primary hazard versus time superimposed on a graph of pupil diameter versus time for an example of an OHAD inducing pupil contraction.

[00036] Figure 19 illustrates a comparison of methods for using an OHAD with a primary optical hazard.

[00037] Figure 20 illustrates a comparison of methods for using an OHAD with a primary optical hazard.

### **Detailed Description**

[00038] Figure 1 illustrates an example of a system including an optical hazard avoidance device (OHAD). The system includes a power supply **12**, which provides or directs

power to a controller **10** that controls the operation of components of an OHAD including a laser **40** and an array **50**, such as an array of speakers, light emitting diodes, microwaves or other sources of radiation. A potential optical hazard **30** is represented by a device, such as a laser, for example. Optical hazards may be mitigated by an OHAD for standoff detectors used in the field, for example, and may be useful with other optical hazards, such as energy sources used in industrial processes, such as curing epoxy, communications, target identification and the like. The first laser **40** and the second laser **30** emit beams **41**, **31** of radiation, which may be visible light or radiation that is not in the visible spectrum, which may be referred to as light herein, even if the radiation is in the non-visible spectrum, such as infrared or ultraviolet. Optics **20** is capable of superimposing the first beam **41** along the same path as the second beam **31**, such that the OHAD laser **40** follows the same path and is reflected, refracted and otherwise scattered similarly to the first beam **31**. The array **50** is arranged as a concentric annulus around the second beam **31**, which passes through a hole **52** in the array **50**, and the array **50** provides a more highly divergent radiation **51** than the second beam **31**. The radiation **51** of the array **50** converges at a first distance **A** from the array **50**. In one example, the array **50** has an intensity of light that is eye safe but is capable of stimulating an avoidance response from first distance **A** to a second distance **B**.

[00039] In one example, the first laser **40** of the OHAD is eye safe at least at the second distance **B** or nearer and is capable of stimulating an avoidance response, such as a blink reflex, to a third distance **C**, beyond which the beam **31** of the potential optical hazard **30** is sufficiently attenuated to be eye safe, according to the standards in ANSI Z136.1-2007, which is the applicable standard of eye safety for lasers in the United States, for example.

[00040] Figure 2 illustrates one example of timing used for controlling a light source, such as a laser, in an OHAD using a controller **10**. The ordinate (x-axis) is time and the abscissa (y-coordinate) illustrates the comparative timings in Figures 2 and 3. In Figure 2, the controller **10** activates the OHAD at a first time **D**, which stimulates a blink reflex at a second time **E** prior to the activation of an optical hazard, such as a laser, at a third time **F** for each pulse of the potentially hazardous source of radiation.

[00041] Figure 3 illustrates an alternative example for timing of an OHAD. In this example, a controller **10** repeatedly flashes the OHAD source or sources, stimulated a blink response (Blink) repeatedly during continuous operation of a potentially hazardous source of radiation, such as a laser (LASER), resulting in a much reduced exposure (Exposure). Furthermore, the repetition of the flashes could result in an avoidance response (Avoidance) that causes any person illuminated by the OHAD to avert the person's gaze from the direction of the potentially hazardous source of radiation, further reducing exposure, completely, at some point in time **G**.

[00042] A hazard region encompasses a limited area, volume or direction with respect to a person's field of view. Radiation may directly or indirectly cause a hazard in a zone when radiation is directed toward a human or animal. Indirect exposure may be caused by scattering, reflecting or refracting of radiation, for example. An OHAD that follows the beam **31** of the hazardous radiation source has the advantage of being scattered, reflected and refracted similarly to the hazardous beam **31**, provided that the wavelength is not too different from the source of the hazard; however, the beams **41**, **51** of OHAD need not be co-linear with the beam **31** of the hazardous radiation source in order to stimulate an avoidance response in a hazard region. For example, the array **50** may provide a source of light that stimulates a blink response or repetition of a plurality of blink responses by flashing a plurality of light emitting diodes (LED's) within the array at the same time or at different times. In one example, the flashing of one set of LED's overlaps with the flashing of a following set of LED's such that flashing causes blink responses to occur very rapidly one after the other, leading any person in the particular hazard region to avert the person's gaze, entirely away from the potential hazard. Sound and heat may be generated in pulses or continuously to stimulate an aversion response, also, using an array **50**.

[00043] In addition, the controller **10** may modulate the power, wavelength, divergence or other optical properties of the potentially hazardous source of radiation or the components of the OHAD in order to stimulate an avoidance response within a hazard region before and during the time the potentially hazardous source of radiation creates a hazard region. Aversion responses may include one or a combination of blink reflex, pupillary response, accommodation reflex, saccade or other involuntary responses, for example. Preferably, an

aversion response will cause a person in a hazard region to redirect the person's gaze away from any potential hazard. Alternatively, the OHAD may limit the exposure or damage by altering the eye's susceptibility to ocular damage.

[00044] Any radiation in excess of a maximum permissible exposure within a nominal hazard zone may be mitigated or avoided entirely by using a method of optical hazard avoidance using an OHAD, even if a person within a nominal hazard zone otherwise would suffer ocular damage from line of sight exposure within the person's field of view. According to the standard a blink reflex occurs no later than 0.25 seconds after the OHAD stimulates the blink reflex; therefore, the time between activating the OHAD **D** and the blink reflex **E** may be 0.25 seconds or longer in Figure 2, for example. In Figure 2, the length of the pulse of the hazardous radiation source is less than the length of a blink, which protects any person within the hazard zone from ocular damage. For example, the hazardous source could be an Nd:YAG laser with a wavelength about 1064 nanometers, and the OHAD may include a laser beam of visible light with a wavelength of 532 nanometers generated using a harmonic crystal **44**, illustrated in schematically in Fig. 1., in the path of the beam **31** of the hazardous source **30**. In this example, a single laser **30** in combination with the controller **10** and the harmonic crystal **44** may provide the light for stimulating an avoidance response for the OHAD and the potentially hazardous radiation. Likewise, the same Nd:YAG laser might be used to generate a beam at 532 nanometers and the crystal could be used to generate a potentially hazardous beam at a wavelength of 266 nanometers, under the control of the controller **10**.

[00045] In one example, a standoff Raman Spectroscopy system is coupled with an OHAD capable of causing gaze aversion. For example, a TEPS system is disclosed in U.S. Pat. No. 8,125,627, the specification of which is incorporated herein in its entirety for the purpose of disclosing a TEPS system. Alternatively, UV-Raman, LIBS, infrared and other sources of radiation may be used in systems that require hazard mitigation provided by an OHAD, for example. Figure 4 illustrates, schematically, a first optical source from a source, such as a detector, that is combined with a second optical source of an OHAD, for example. For example, the OHAD emits a laser beam in the visible light spectrum that is capable of causing gaze aversion. An optical combiner is illustrated in the drawing, but other optical arrangements may be used to combine the two light sources, provided that the OHAD beam width is selected to

cause gaze aversion in a width at least as wide as the portion of the beam width of the optical hazard that presents an optical hazard. The example in Figure 4 is illustrative and an OHAD may comprise additional optical elements or alternative arrangements of optical elements. For example, Figure 5 illustrates an intensity of a first optical source and a second optical source, which shows that the second optical source beam width is wider than the first optical beam width. In one example, the intensity of the second optical source is greater than the minimum radiation level required to stimulate a physiological response across a width **A** greater than the width **B** of the portion of the first optical source that exceeds the maximum permissible exposure for the first optical source. For example, the intensity of the second optical source may be greater than the critical response threshold over a particular range. The particular range may include all ranges over which the first optical source is hazardous or may include only a portion of the range over which the first optical source is hazardous. In one example, the particular range limits the optical hazard associated with the first optical source to a range very near first optical source, which limits the exclusion area required for firing of the first optical source.

[00046] For example, Figure 6 illustrates an example in which the first optical source is a diverging beam having a first optical hazard range **C** and the second optical source is a wider diverging beam creating a physiological response up to and including a range **D** greater than the optical hazard range **C**. In contrast to Figure 6, Figure 7 illustrates an optical hazard with a focal point down range that results in an intermediate optical hazard range **E**. For example, the range of the physiological response **D** is greater than, spans and includes the intermediate optical hazard range **E**. Alternatively, only a portion of the entire nominal hazard range is covered by the range of the physiological response(s) stimulated by an OHAD. In this alternative example, the risk associated with a nominal hazard may be nonetheless mitigated substantially. Alternatively, the physiological response(s) may be sufficient to entirely prevent ocular damage over entire range in which an optical hazard exists, when the first optical source is active. Alternatively, even though the physiological response is initiated, the physiological response may not entirely prevent ocular damage over the entire hazard range. Instead, the physiological response may mitigate the extent of ocular damage or may entirely prevent ocular damage only when combined with other techniques, such as an exclusionary zone. For example, the physiological response may mitigate damage causing such damage to be temporary, rather than permanent.

[00047] Figures 8-8C illustrate how beam width and range are both relevant in OHAD applications. Figure 8 illustrates two diverging sources. Figure 8A illustrates the beam widths and intensities at A'. Figure 8B illustrates the beam widths and intensities at B'. Figure 8C illustrates the beam widths and intensities at C'. At C', the intensity of the second source is less than that at which a physiological avoidance reaction would be stimulated, but the beam intensity of the first source is well within safe levels for the designed duration of exposure. At B', the first source is at the intensity that risks ocular damage of some type; however, the second source has an intensity and beam width that causes an optical hazard avoidance response, specifically, a physiological avoidance reaction, such as gaze aversion. The intensity of the second beam does not exceed its maximum permissible exposure (MPE), as defined in ANSI 136.1 (2007) and the avoidance reaction is capable of limiting the exposure of the viewer to the first source, such that the viewer is not exposed to the maximum permissible exposure of the first source, even though the viewer would otherwise be in danger of ocular damage. At A', the MPE of the first source would be exceeded, except for the avoidance reaction induced by the second source, and the intensity of the second source remains in a safe range, less than the MPE of the second beam. For example, Figures 9A-C illustrate an OHAD that emits a bright light with a width as shown in the images, which is shown to extend beyond a 4-inch circle (i.e. 2.54 cm per inch). Light from the first source never presents an ocular hazard beyond the 4-inch circle over these ranges A', B' and C'.

[00048] Figure 10 illustrates an example of a graph of an aversion beam intensity versus distance in meters (i.e. range) for one example of a detector's aversion system using a 40 milliwatt continuous laser as the source of the aversion beam. It is believed that a gaze aversion is stimulated in the example shown in Figure 10 at a range up to B"; however, a range up to A" may be selected for operationally ensuring that a gaze aversion response will mitigate or eliminate nominal risk of damage from a primary optical hazard. In one example, the primary optical hazard is integrated with an OHAD, such that the primary optical hazard does not have a beam with a converging, focused beam width, down range of the source of the primary optical hazard. For example, the OHAD may have a diverging beam that encompasses the entire width of a diverging primary width of a beam of an optical hazard, until the intensity of the diverging optical hazard, with distance down range, falls below a threshold level defining a nominal hazard zone as defined in ANSI standards. Figure 11 illustrates another example with the ANSI Z136.6

Sensitive Level superimposed on the graph, showing a range in meters for the aversion response induced by the aversion system. Figure 12 illustrates another example, using a 3 milliwatt laser power output and superimposing maximum permissible exposure for the aversion beam when viewed through a 7X optical aid, such as binoculars. By implementing an OHAD that is safe even if viewed through a 7X optical aid, the ANSI Z136.6 Sensitive Level is never reached. Instead, the system uses the ANSI Z136.6 Critical Level for determining the effective range of the aversion response. Herein, “effective range” of an OHAD refers to the range associated with the desired response. The ANSI Z136.6 Critical Level, unless otherwise indicated, is presumed to be the effective range of an OHAD. Figure 13 illustrates an example of a laser used for generating an aversion beam mounted in an optical configuration including two alignment mirrors, a beam expander and a 100 mm beam collimator with the beams represented as shaded solids. Figure 14 illustrates a side plan view of the example represented in Figure 13. The laser **145** is directed toward a first alignment mirror **143** which directs the beam **140** toward a second alignment mirror **141**. The second alignment mirror **141** redirects the beam **140** to a beam expander **147**, which expands the width of the beam. A beam collimator **149** collimates the beam **140**, which may continue to diverge over the range of the beam but not to the extent that it does between the beam expander and the beam collimator. The beam **140** then proceeds down range and provides for an aversion response, such as gaze aversion, for example. Figure 15 illustrates a perspective view of the example illustrated in Figure 14.

[00049] For example, Figures 16 and 17 illustrate examples of the maximum permissible exposure for ocular safety with gaze aversion (solid line) and without gaze aversion (dashed line) for an optical hazard comprising a laser having a wavelength of about 248 nanometers utilizing 500 pulses per second with a 20 nanosecond duration (Figure 16) or a 1064 nanometer wavelength laser utilizing 5000 pulses per second with a 10 nanosecond pulse duration (Figure 17), wherein the term “about” recognizes that the beam is not exactly 248 nanometers, but is characterized as being about 248 nanometers within ordinary specifications for sourcing such a laser. Likewise, other wavelengths in this description should be considered as being modified by “about” whether it is indicated or not in the particular description. In both examples, the maximum permissible exposure per pulse for ocular safety is increased to a surprising and unexpected degree compared to the limit without the use of a gaze aversion source incorporated as an ocular safety device. In the example of the ultraviolet source, in Figure 16,

the permissible exposure per pulse is increased by more than an order of magnitude, allowing a much more powerful beam to be used in a device, such as a laser range finder or detector.

[00050] For example, it is believed, without being limiting in any way, that one example OHAD is capable of being implemented with a UV Raman trace chemical detector. In this example, the use of the OHAD limits the nominal hazard zone as defined in ANSI Z136.1 (NHZ) from 170 acres, making the detector impractical to use in any populated area, to just one-third of an acre, which is entirely manageable. In this example, a 248 nanometer wavelength UV Raman spectroscopy detector is utilized with a 15 centimeter aperture, 2 milliJoule pulse power, 300 Hz repetition rate for interrogating a target for 60 seconds from 40 meters away with a 1 square centimeter spot size. In this example, a UV Raman spectroscopy detector is entirely impractical for ocular-safe use within a populated area without OHAD and becomes completely practical when OHAD is utilized, making deep UV Raman usable as a detector in populated areas. This surprising and unexpected result combines synergistically a comparatively low power visible laser to induce an involuntary gaze aversion response with the UV Raman source for inducing detectable inelastic scattered light from a material, for example. In one example, a motion sensor is coupled with the OHAD and detector to prevent emission of either or both sources if movement is detected with the NHZ. The OHAD reduces the NHZ to a manageable area that is capable of being monitored by the motion sensor, for example. Utilizing the combination of a motion sensor and OHAD, there is no nominal optical hazard. Even if a motion sensor were used in the UV Raman system without OHAD, an optical hazard could exist outside of the range of practical motion sensors available for use with a UV Raman system.

[00051] Alternately, eye damage might not occur even though a nominal hazard exists. Nevertheless, a useful detector system would not meet safety standards for use. The nominal hazard calculations in the standard include safety factors and exposure at the MPE (a nominal optical hazard) is likely to not actually cause ocular damage. Nevertheless, a device including an optical source exceeding MPE would be judged to raise a nominal optical hazard; therefore, such a device would not be approved for use. In contrast, by combining one or more OHAD, the device could be approved for use by avoiding a nominal optical hazard.

[00052] One example of an aversion response is pupil contraction. Pupil contraction response is a comparatively slow, involuntary response to an exposure to a bright light source, with a typical latency period of 100 to 300 milliseconds. In one example, a secondary source is selected with a wavelength and an intensity such that pupil contraction is initiated. Table 1 provides values of an example for nominal retinal hazard mitigation by pupil contraction with a visible primary source duration in seconds. For example, pupil contraction may be initiated prior to the initiation of a primary optical hazard such that a pupil contraction response is initiated prior to the initiation of the primary optical hazard or hazards, such as at 100 milliseconds, more preferably at 200 milliseconds, even more preferably at 250 milliseconds or 300 milliseconds, such that retinal exposure to a pulsed or continuous primary optical hazard or hazards does not exceed a nominal optical hazard. For example, a secondary source for initiating a pupil contraction response is limited to visible wavelengths, which fall within the range of wavelengths that would subject the retina to damage, also. Therefore, such an OHAD would be applicable only for protection against hazardous optical sources, such as lasers, comprising wavelengths in the visible (400-700 nm) or near-infrared (700-1400 nm). An OHAD utilizing a pupil contraction response and no other optical hazard avoidance response would provide no benefit for a primary optical hazard in the UV (less than 400 nm) or far-infrared (greater than 1400 nm), which could cause corneal damage regardless of pupil size. It may take up to about 2 seconds for a pupil to contract completely, although significant pupil contraction may occur within 0.5 seconds, even for a dark adapted eye. An OHAD strategy utilizing pupillary contraction response is illustrated in the graph of Figure 18, for example, with a plurality of primary laser pulses timed to coincide with the pupillary contraction response induced by the OHAD visible optical source. In one example, a visible light OHAD is combined with a near-infrared primary laser. As is often assumed in calculating ocular hazards, such as in ANSI Z136.1, the viewer is assumed to have dark adapted pupils, with a nominal pupil diameter of 7 millimeters. In this example, it is assumed that no gaze aversion is stimulated.

[00053] For example, as illustrated in Figure 19, the visible light OHAD is triggered 0.5 seconds (solid lines) prior to the triggering of a near-infrared primary source, causing a viewer's pupil to contract prior to the triggering of the primary source. As a result, the retinal dose rate is dramatically reduced. If fired at the same time as the primary source (dashed

lines), the OHAD still provides a reduced dose rate compared to no OHAD (dotted lines), but the dose rate during the first 0.5 seconds is increased in comparison.

[00054] In comparison, a visible light OHAD with a visible light primary source is illustrated in the example of Figure 20. It is assumed in Figure 20 that the OHAD has a negligible impact on the overall retinal dose rate (i.e. low power compared to the primary source causing the optical hazard) and no gaze aversion response is induced, then the only benefit is gained by activating the OHAD before the primary source, which extends only for the pupil contraction time, which is assumed to be 0.5 seconds in the example). Under these conditions, the triggering of the OHAD at least 0.5 seconds prior to the primary source induces pupil contraction, which limits retinal dose rate.

[00055] In another example, blink aversion may be adopted by using an OHAD visible laser source to cause viewers to blink. The latency of the blink aversion response is thought to be 250 milliseconds and protects both the cornea and the retina from damage. Therefore, this response is suitable for all primary source wavelengths. In this example, the critical level for the OHAD is the level required to cause a nominal blink response, which might vary depending on ambient lighting conditions and to some degree on characteristics of the observer including medical conditions and use of legal and illegal drugs. This critical level for a blink response may be determined by characterizing the blink response to a secondary optical source emitting light in the visible spectrum. Alternatively, a blink response might be induced by a critical level of noise, directed or omnidirectional. Such a blink response may be initiated prior to the initiation of a primary optical hazard, such that the blink response substantially reduces or entirely eliminates exposure to the primary optical hazard, for example.

[00056] In yet another example, gaze aversion response is adopted by using an OHAD visible laser source to cause viewers to avert their gaze. Table 2 summarizes the benefits achieved from gaze aversion response. The benefits to ocular safety are surprisingly and unexpectedly great for the ultraviolet range of primary sources, which will reduce the exposure by 1200 times compared to the primary source without an OHAD utilizing the gaze aversion response, as illustrated in the example graph in Figure 16, for example. There is no practical limit on the effective benefit of the gaze aversion response, which depends on the length of

exposure to which the gaze is averted and the wavelength of the primary optical hazard. Longer exposures to a primary UV optical hazard can reduce the exposure by 1200 times (at five minutes), for example, compared to the same exposure without stimulating the gaze aversion response using an OHAD. Dose mitigation is defined herein as the dose without OHAD divided by the dose with OHAD, and as represented in Table 2, is shown as the number of times by which human exposure is reduced (e.g. 4X or 4 times less exposure for a 1 second exposure to a primary optical hazard mitigated by gaze aversion). See Table 2 for a summary of exposure reduction by gaze aversion for a 5 nanosecond, pulsed laser having a 248 nanometer wavelength. Table 2 assumes that the OHAD is triggered at the same time as the primary laser. No blink response or pupil contraction response is considered in Table 2. A visible beam of a primary source itself induces a gaze aversion; therefore, no calculation is provided for a primary source emitting light in the visible range of wavelengths. However, inducing a gaze aversion with a secondary source or a lower intensity beam from the primary source, itself, could reduce latency, if initiated 250 milliseconds before the power-up of the primary hazard source emitting a visible beam. This effect is not considered in Table 2.

[00057] The scan times of a detector, which is taken as the duration of a primary optical hazard, in Table 2, are representative of the range of scan times utilized in UV Raman spectroscopy detectors, such as Checkpoint Explosives Detection System (CPEDS)<sup>1</sup>, e.g. a dual-band ultra violet (UV) Raman standoff detection technology to detect trace residue from explosives chemicals and associated precursor materials with laser excitation wavelengths of 248 nanometers and 355 nanometers. It should be noted that the duration of a scan is not necessarily a continuous exposure to a primary optical hazard, because the primary optical hazard may be pulsed. Based on Table 2, gaze aversion is a preferred optical hazard avoidance mechanism for an OHAD preventing damage in UV Raman spectroscopy detectors. The multiplier for intensity of the primary optical source compared to no gaze aversion is both surprising and unexpected in its magnitude, especially at longer scan times. At long scan times, the nominal hazard mitigation provided by induced gaze aversion due to an OHAD is extraordinary. It is presumed in Table 2 that the visible beam of an OHAD contributes nothing to the exposure, which is a reasonable

---

<sup>1</sup> CPEDS is a trademark of Alakai Defense Systems.

presumption, in part, because while a UV hazard source represents a hazard to the cornea, the visible aversion source does not represent a hazard to the cornea. The visible source threshold is for damage to the retina; therefore, the a visible OHAD adds nothing to the potential cornea damage caused by a UV hazard, for example.

[00058] In one example, an OHAD combines a plurality of aversion responses. For example, pupil contraction response is combined with gaze aversion response or blink response is combined with gaze aversion response. For example, gaze aversion response provides 1200 times exposure (at 5 minutes) for a UV primary source and 2.5 times exposure for near-infrared and far infra-red primary sources, for the same duration of exposure, while pupil contraction response provides up to 12 times exposure for visible and near-infrared primary sources. In this example, the combined benefit for a UV primary source is 1200 times exposure, for visible primary source is up to 12 times exposure, for near-infrared is up to 30 times exposure (i.e. combining 2.5 times and 12 times), and for far-infrared is 2.5 times exposure. Furthermore, triggering of an OHAD prior to the primary source, such as at 0.5 seconds prior, can reduce retinal dose rates in the visible and near-infrared spectrums.

[00059] One or more aversion responses may be combined with a motion sensor or other interlocking device to increase ocular safety within an NHZ, if necessary. Also, a blink response may be utilized to reduce the exposure to both retina and cornea to nothing during the period when the eyelid is closed. By combining physiological responses as a result of an OHAD and other safety devices, damage that could be caused by a wide variety of optical hazards may be mitigated or avoided.

[00060] In one example, such as illustrated schematically in Figure 4, a detector 400 comprises a first optical source 410, such as a primary laser, the first optical source having an optical hazard zone C, E, such as illustrated in Figures 6 and 7. The detector 400 comprises a sensor 420 for interrogating a signal from a substance stimulated by the first optical source 410, such as illustrated schematically in Figure 4, for example. The detector 400 comprises a second optical source 440, such as a secondary laser beam 140, which may be emitted by a secondary laser. For example, the secondary laser beam 140 comprises a visible beam with an optical intensity selected for stimulating at least one physiological aversion or avoidance response in a

human. The detector **400** comprises an optical system **147, 149** for directing the visible beam such that the visible beam is superimposed over a beam **142** emitted by the primary optical source **410** in at least a portion of the nominal hazard zone **C,E** of the primary optical source **410**. The second optical source **440** may be capable of inducing the at least one physiological aversion or avoidance response in at least the portion of the nominal hazard zone of the primary laser, such that optical exposure to the beam emitted by the primary optical source **410** is mitigated or eliminated by the at least one physiological aversion or avoidance response stimulated in humans by the second optical source **440**. For example, the beam **142** of the primary laser comprises emitted energy having an ultra-violet wavelength, such that no visible light is emitted by the primary optical source **410** and no physiological aversion or avoidance response is stimulated by the primary optical source **410**. In one example, the beam of the primary optical source **410** includes one or more lasers and comprises emitted energy comprising dual-band ultra-violet wavelengths. The sensor and primary laser may provide a system for Raman standoff detection such that trace residue from chemicals produce a signal when exposed to the dual-band ultra-violet wavelengths, for example. The dual-band ultra-violet wavelengths may include emitted energy at wavelengths of 248 nanometers and 355 nanometers, for example. In one example, the optical system includes a first mirror **143** for redirecting the visible beam from the second optical source **440** and a second mirror **141** for redirecting the visible beam redirected by the first mirror **143**, such as illustrated in Figures 13-15, for example. The optical system may include a beam expander **147**, and the visible beam from the second mirror **141** may be directed through the beam expander **147**, such that the beam diverges. After the visible beam is directed through the beam expander **147**, the visible beam may be directed through a beam collimator **149**, such that the diverging visible beam becomes more collimated, such that the effective width **A** of the collimated beam **140** is greater than the nominal hazard width **B** of the beam **142** of the primary optical source **410**, as illustrated in Figures 4-5 and 13-15, for example. Herein, effective width refers to the width of the beam of a secondary optical source of an OHAD that corresponds to the minimum optical intensity level for the beam of the secondary optical source to stimulate a selected physiological response.

[00061] The optical system may include an optical combiner **450**, such as illustrated schematically in Figure 4, which may be disposed after the beam collimator **149**, for example, whereby the visible beam **140** is superimposed over the beam **142** emitted by the

primary optical source **410** in at least a portion of the optical hazard zone of the beam **142** of the primary optical source **410**. The optical system may include beam targeting optics **430**, such as an adjustable targeting mirror, wherein the beam targeting optics **430** are capable of redirecting both the visible beam **140** of the secondary optical source **440** and the beam **142** of the primary optical source **410** toward a target (not shown) at a distance from the detector **400**.

[00062] In one example, a time delay circuit **462** is included in a controller **460**, which may be provided as an interlocking device, such that triggering of the detector delays for a delay time or prevents any initiation of the beam **142** emitted by the primary optical source **410**. For example, the delay time may delay the primary optical source until after the initiation of the visible beam **140** of the second optical source **440**. In one example, a delay of 100 milliseconds, 200 milliseconds, 250 milliseconds or 300 milliseconds may be selected. For example, a sensor **420** may be integrated with the controller **460** to determine when or if the second optical source **440** is operational. If the sensor **420** does not detect the visible beam **142**, or the visible beam **142** is detected at less than a threshold level, then the interlocking device may prevent the triggering of the primary optical source **410**. In one example, a manual override **463** may be provided to override the interlocking device **464**, as illustrated schematically in Figure 4. Alternatively, the detector may not have a manual override.

[00063] A time delay circuit may be capable of delaying the initiation of the beam **142** emitted by the primary optical source **410** for at least 100 microseconds, for example, such that a pupil contraction or blink response may be initiated by the second source **440** prior to triggering the beam **142** of the primary optical source **410**. In one example, the time delay circuit is capable of delaying the initiation of the beam emitted by the primary laser for at least 250 microseconds.

[00064] A method of implementing an optical hazard avoidance device may comprise a step of selecting an optical hazard avoidance system that combines a plurality of optical hazard avoidance responses in a human. Herein, an optical hazard avoidance response is defined as a physiological or behavioral response that is capable of mitigating damage that would otherwise be caused by a nominal hazard to human ocular tissue including retinal damage or corneal damage, wherein the nominal hazard is defined within a nominal hazard zone in the

ANSI standard. The plurality of optical hazard avoidance responses selected from the optical hazard avoidance responses may consist of a blink response, a pupil contraction response and a gaze aversion response, for example. The method may include integrating the optical hazard avoidance system with a primary optical hazard, such that the optical hazard avoidance system mitigates or eliminates nominal risk of damage to a cornea or a retina of the human. By nominal risk of damage it should be understood that ANSI Z136.1-2007 is being used herein to determine whether there is a nominal risk of hazard within a nominal hazard zone (NHZ) when the primary optical hazard is operated absent the optical hazard avoidance device (OHAD), and the OHAD operates to mitigate or eliminate the nominal risk of hazard within at least a portion of the NHZ. ANSI 136.6 is used, also, such as when determining the Sensitive Level and the Critical Level, as illustrated in the drawings. Other standards exist, such as found in 21 C.F.R. 1040, DODI 6055.15 or IEC 60825, but the ANSI standards in 136.1 and 136.6 are used consistently to define the levels used herein. The OHAD may provide a motion sensor or other sensor to prevent triggering of a primary optical hazard, when a human is detected within any residual NHZ, for example. By combining an optical hazard avoidance response with an interlocking device, the interlocking device is capable of preventing the firing of the primary optical hazard until the optical hazard avoidance device determines that the firing of the primary optical hazard is safe to humans. The control or controller **460** may include an interlocking device **464** and a time delay circuit **462** or the interlocking device may include the time delay circuit **462**. Combining an interlocking device in an OHAD system may be used to prevent the firing of the primary optical hazard for a predetermined time delay period or for a time delay period selectable by a user of the OHAD. The time delay period may be at least 100 milliseconds, more preferably at least 250 milliseconds, if a blink response or pupil contraction response is required prior to the triggering of a primary optical hazard.

[00065] In one example, the step of combining includes monitoring a nominal hazard zone for the presence of a human and preventing the firing of the primary optical hazard until all humans are excluded from a residual nominal hazard zone. By residual nominal hazard zone, it is meant the nominal hazard zone, if one exists, after the mitigation by the OHAD of the nominal risk of damage from a primary optical hazard is taken into consideration. In an alternative example, a time delay is provided even after all humans are excluded from the residual nominal hazard zone. The step of monitoring may be automated by providing a sensor

capable of detecting a human/animal within the residual nominal hazard zone, such as a motion sensor. For example, when a motion sensor has detected motion consistent with the presence of a human within the residual nominal hazard zone during a period prior to triggering of the primary optical hazard, the interlocking device prevents the firing of the primary optical hazard. When the interlocking device prevents the firing of the primary optical hazard, an audible or visible warning or alarm may be provided. For example, such a warning or alarm may indicate to the user of a detector that the nominal hazard zone is not clear and/or may provide a warning to any person in the residual nominal hazard zone. In one example, a human face detection system is incorporated into the OHAD, such as the human face detection module disclosed in U.S. Pat. Publ. No. 2007/0098229, published May 3, 2007, and U.S. Pat. No. 6,184,926, which issued February 6, 2001, which discloses a system for detecting a human face in uncontrolled environments, the entire disclosures of these references being incorporated in their entirety herein by reference.

[00066] One example of a method of using an optical hazard avoidance device to mitigate or eliminate a nominal optical hazard within a nominal hazard zone comprises selecting an optical hazard avoidance device having an intensity and wavelength of emitted radiation such that a plurality of optical hazard avoidance responses mitigate or eliminate a nominal optical hazard of a primary optical hazard. By integrating the OHAD with a primary optical hazard, an interlocking device may prevent triggering of the primary optical hazard until the plurality of optical hazard avoidance responses mitigate or eliminate the nominal optical hazard of the primary optical hazard, for example.

[00067] Other combinations and variations of the features of the examples of the invention disclosed are intended to be included within the scope of the invention, and the examples should not be taken as limiting any of the claims that eventually issue.

[00068] Tables 1 and 2 are provided below:

Table 1.

Primary Source Duration (seconds)	Retinal Hazard Mitigation
0.1	11X
0.5	9X
1	5X
2	3X

Table 2.

Primary Source Wavelength	Primary Source Duration					
	1 sec.	10 sec.	1 min.	5 min.	10 min.	1 hour
UV (<400nm)	4X	40X	240X	1200X	2400X	14400X
Visible (400 – 700)	Not Calculated					
Near-IR (700 – 1400)	1.4X	2.5X	2.5X	2.5X	2.5X	2.5X
Far-IR (>1400)	1.4X	2.5X	2.5X	2.5X	2.5X	2.5X

## WHAT IS CLAIMED IS:

## 1. A detector comprising:

a primary laser, the primary laser having a nominal hazard zone;

a sensor for interrogating a signal from a substance stimulated by the primary laser;

a secondary laser emitting a visible beam for stimulating at least one optical hazard avoidance response capable of mitigating damage caused by the primary laser;

an optical system for directing the visible beam such that the visible beam is superimposed over a beam emitted by the primary laser in at least a portion of the optical hazard zone of the primary laser, wherein the secondary laser is capable of inducing the at least one optical hazard avoidance response in at least the portion of the optical hazard zone of the primary laser such that optical exposure to the beam emitted by the primary laser is mitigated by the at least one optical hazard avoidance response.

2. The detector of claim 1, wherein the beam of the primary laser comprises emitted energy having an ultra-violet wavelength.

3. The detector of claim 2, wherein the beam of the primary laser includes one or more lasers and the beam of the primary laser comprises emitted energy comprising dual-band ultra-violet wavelengths and the sensor and primary laser provide a system for Raman standoff detection such that trace residue from chemicals produce a signal when exposed to the dual-band ultra-violet wavelengths.

4. The detector of claim 3, wherein the dual-band ultra-violet wavelengths include emitted energy at wavelengths of about 248 nanometers and 355 nanometers.

5. The detector of claim 1, wherein the optical system includes a first mirror for redirecting the visible beam from the secondary laser and a second mirror for redirecting the visible beam redirected by the first mirror.

6. The detector of claim 1, wherein the optical system includes a beam expander, and the visible beam is directed through the beam expander, such that the beam diverges, and a beam collimator, wherein, after the visible beam is directed through the beam expander, the visible beam is directed through the beam collimator, such that the diverging visible beam becomes more collimated, such that the effective width of the collimated beam is greater than the nominal hazard width of the beam of the primary laser.

7. The detector of claim 1, wherein the optical system includes an optical combiner, whereby the visible beam is superimposed over the beam emitted by the primary laser in at least the portion of the optical hazard zone of the beam of the primary laser.

8. The detector of claim 7, wherein the optical system includes beam targeting optics, wherein the beam targeting optics are capable of redirect both the visible beam of the secondary laser and the beam of the primary laser toward a target at a distance from the detector.

9. The detector of claim 1, further comprising a time delay circuit, such that triggering of the detector delays for a delay time any initiation of the beam emitted by the primary laser until after the initiation of the visible beam of the secondary laser.

10. The detector of claim 9, wherein the time delay circuit is capable of delaying the initiation of the beam emitted by the primary laser for at least 100 milliseconds.

11. The detector of claim 9, wherein the time delay circuit is capable of delaying the initiation of the beam emitted by the primary laser for at least 250 milliseconds.

12. A method of implementing an optical hazard avoidance device, comprising:

selecting an optical hazard avoidance system that combines a plurality of optical hazard avoidance responses in a human, the plurality of optical hazard avoidance responses selected from the optical hazard avoidance responses consisting of blink response, pupil contraction response and gaze aversion response;

integrating the optical hazard avoidance system with a primary optical hazard, such that the optical hazard avoidance system mitigates or eliminates nominal risk of damage to a cornea or a retina of the human.

13. The method of claim 12, further comprising combining the optical hazard avoidance response with an interlocking device preventing the firing of the primary optical hazard until the optical hazard avoidance device determines that the firing of the primary optical hazard is safe to humans.

14. The method of claim 13, wherein the interlocking device includes a time delay circuit and the step of combining prevents the firing of the primary optical hazard for a time delay period.

15. The method of claim 14, wherein the time delay period is at least 100 milliseconds.

16. The method of claim 14, wherein the time delay period is at least 250 milliseconds.

17. The method of claim 13, wherein the step of combining includes monitoring a nominal hazard zone for the presence of a human and preventing the firing of the primary optical hazard until all humans are excluded from the nominal hazard zone.

18. The method of claim 17, wherein the step of monitoring is automated by providing a motion sensor, such that, when the motion sensor has detected motion consistent with the presence of a human within the nominal hazard zone during a period prior to triggering of the primary optical hazard, the interlocking device prevents the firing of the primary optical hazard.

19. The method of claim 18, wherein, when the interlocking device prevents the firing of the primary optical hazard, an audible or visible warning is provided.

20. The method of claim 17, wherein the step of monitoring is automated by providing a human face detection system, such that, when the human face detection system has detected a human face consistent with the presence of a human within the

nominal hazard zone and facing in a particular direction, during a period, the interlocking device is capable of interrupting the firing of the primary optical hazard.

21. A method of using an optical hazard avoidance device to mitigate or eliminate a nominal optical hazard within a nominal hazard zone, comprising:

selecting an optical hazard avoidance device having an intensity and wavelength of emitted radiation such that a plurality of optical hazard avoidance responses mitigate or eliminate a nominal optical hazard of a primary optical hazard;

integrating the optical hazard avoidance device with the primary optical hazard such that a control device prevents triggering of the primary optical hazard until the plurality of optical hazard avoidance responses mitigate or eliminate the nominal optical hazard of the primary optical hazard.

22. The method of claim 21, wherein the step of integrating includes selecting optics such that the primary optical hazard has a beam and the beam does not have a converging, focused beam width and the optical hazard avoidance device has a beam with a beam width greater than the beam width of the beam of the primary optical hazard within an entire nominal hazard zone of the primary optical hazard.

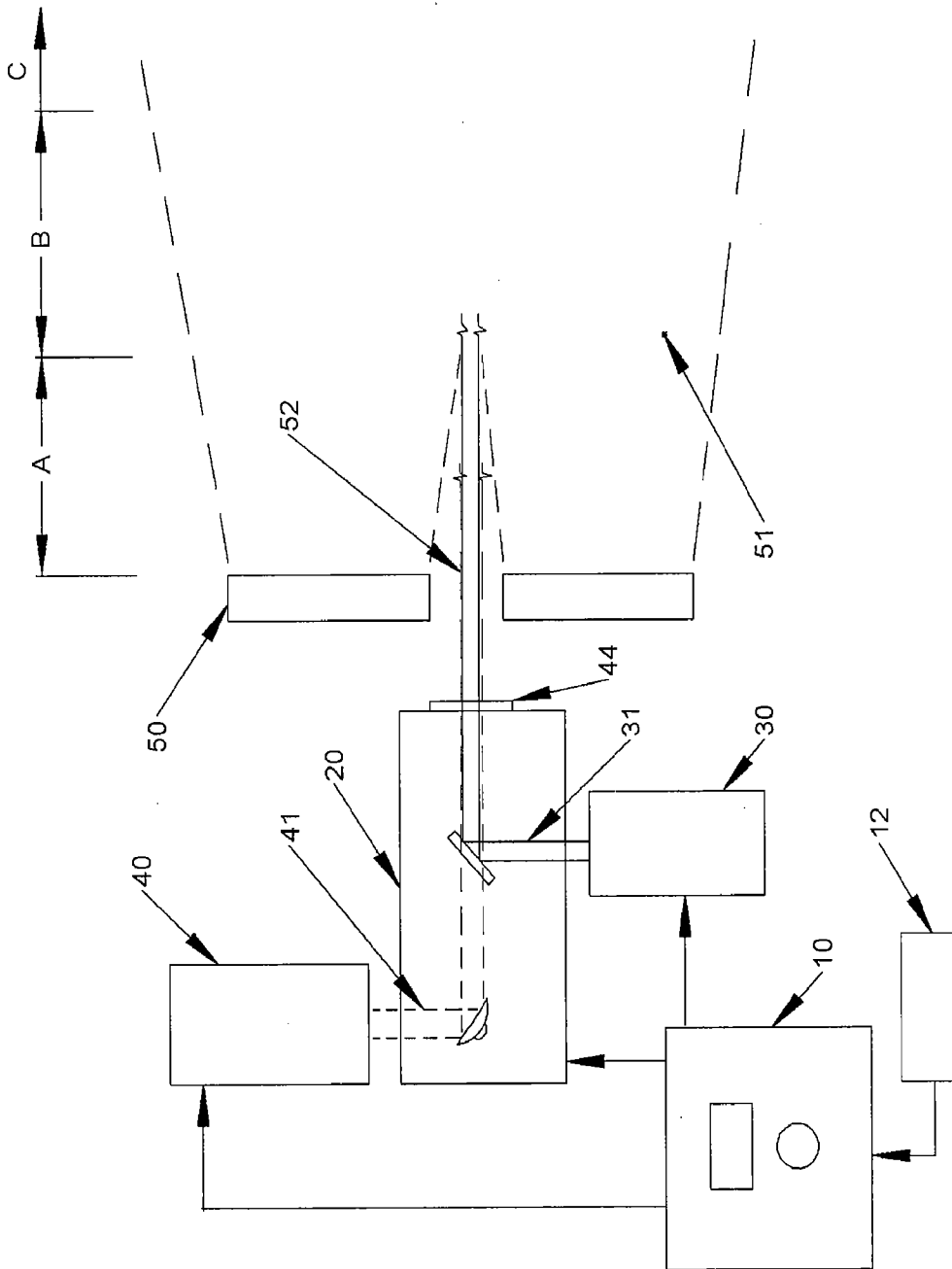

FIG. 1

FIG. 2

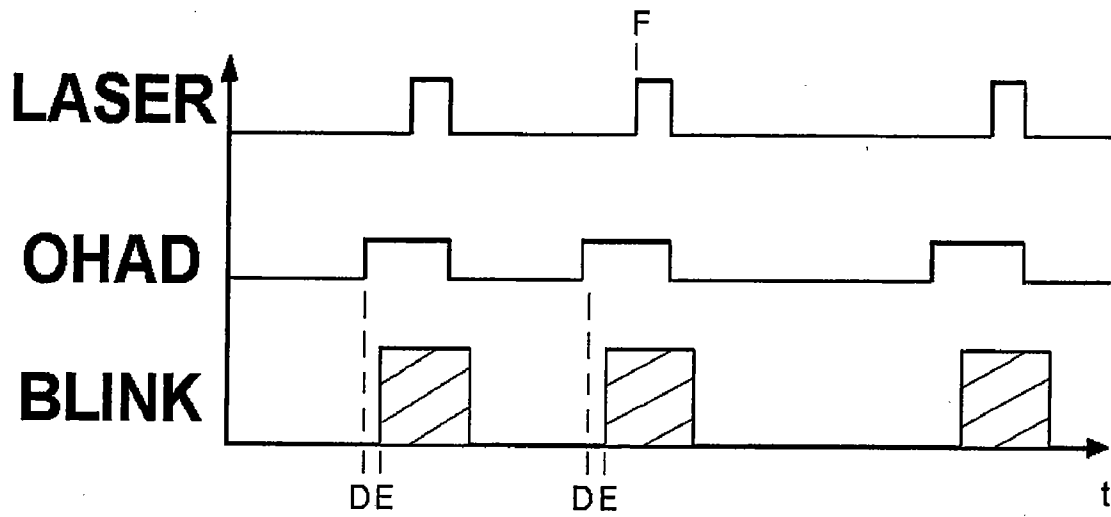
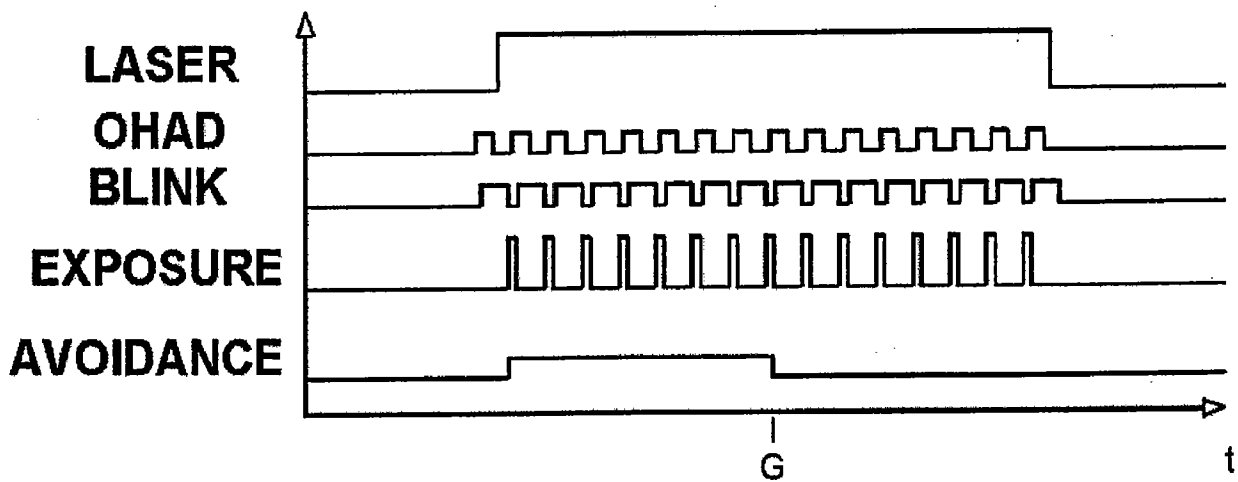

FIG. 3



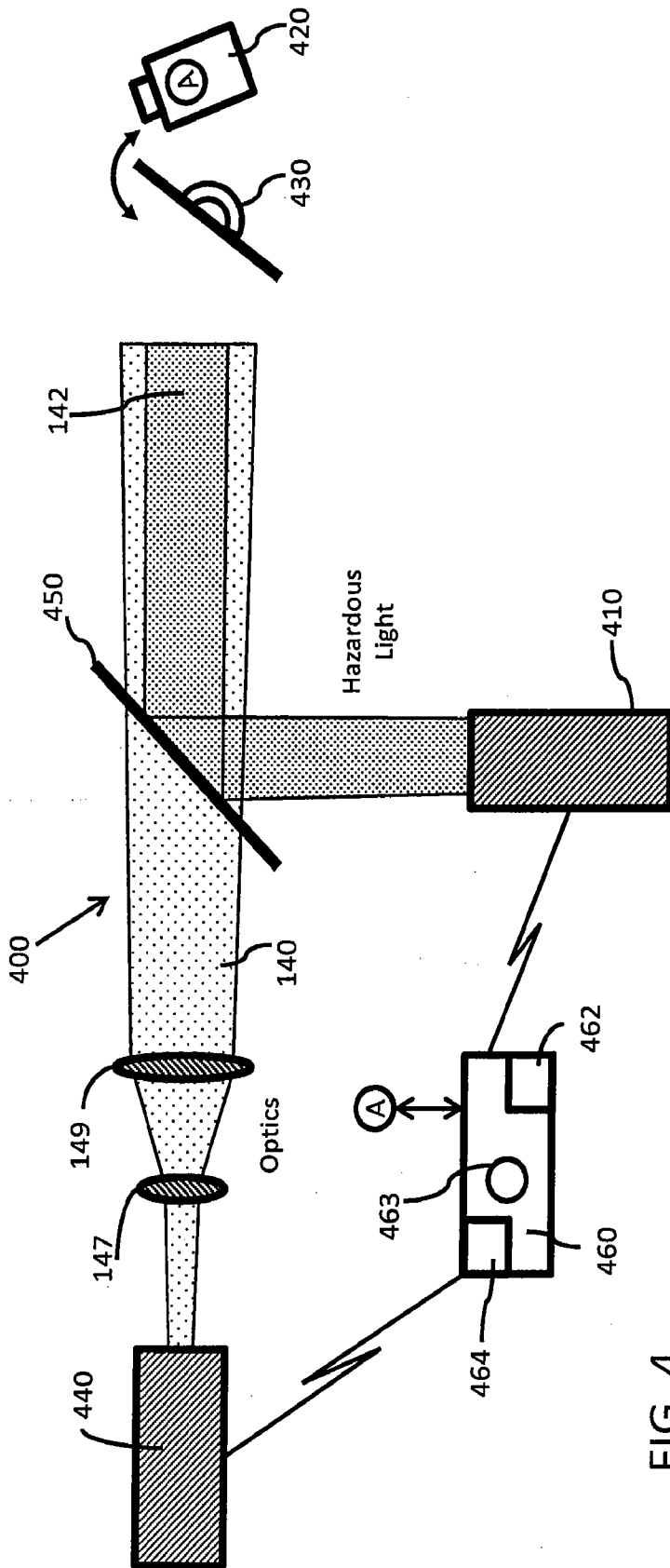

FIG. 4

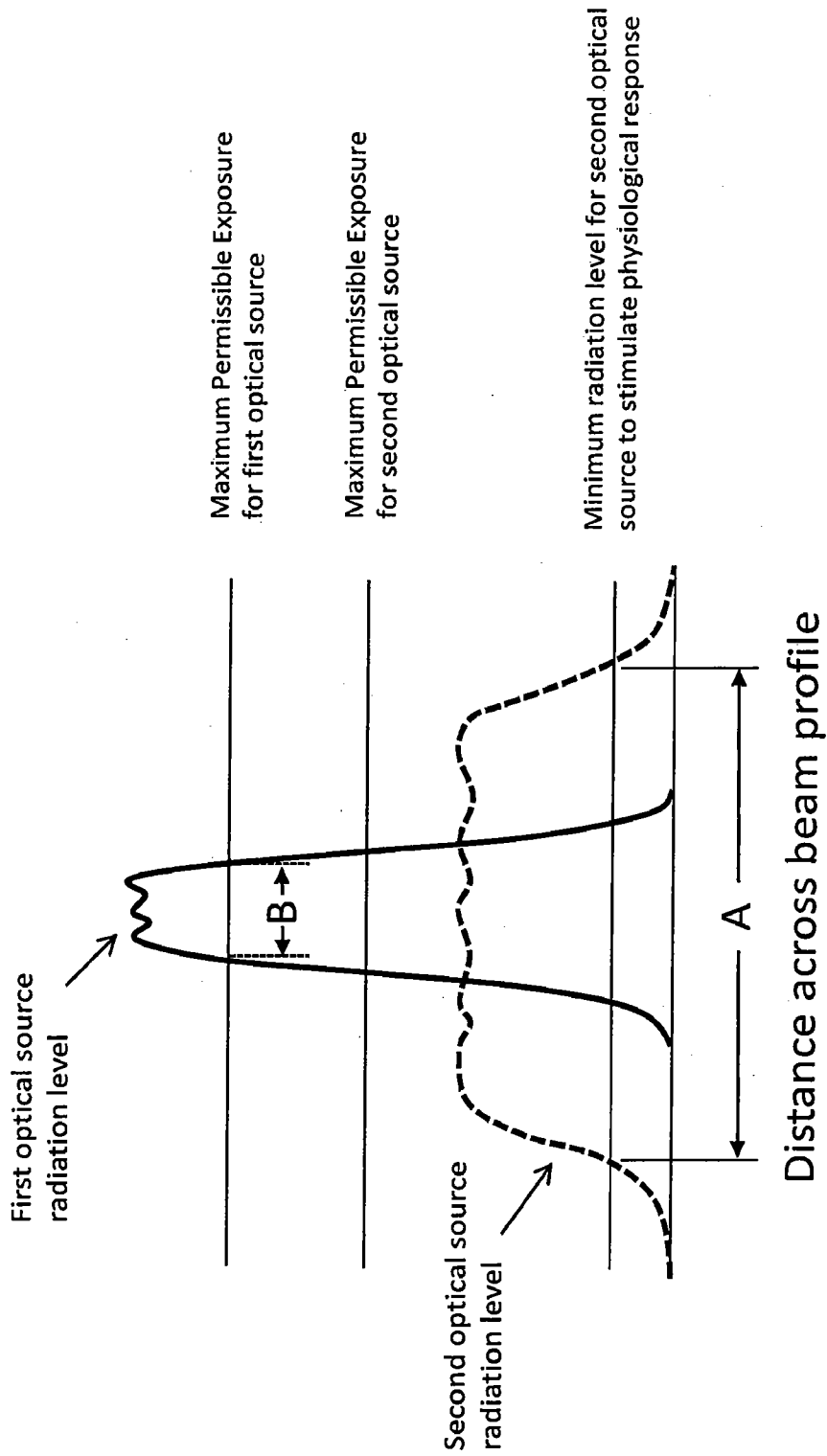

FIG. 5

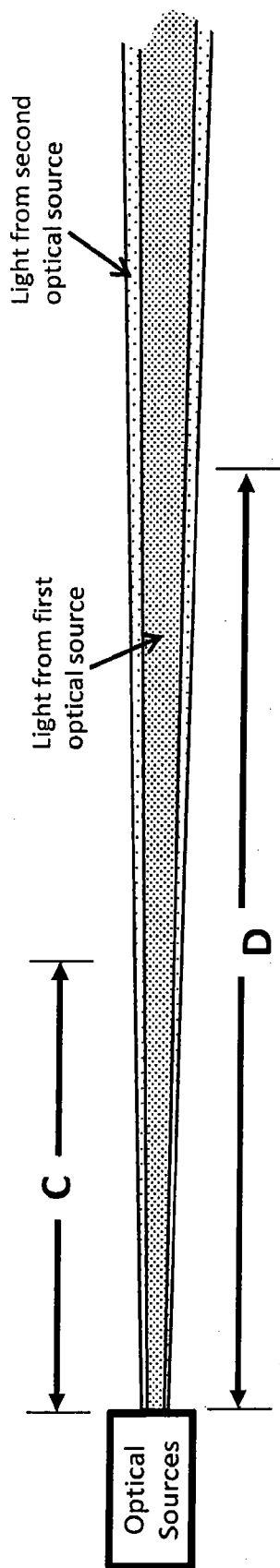

FIG. 6

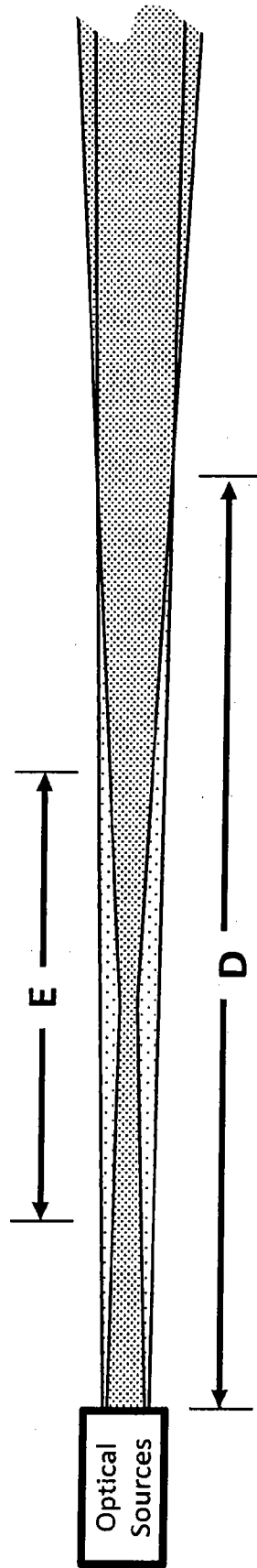

FIG. 7

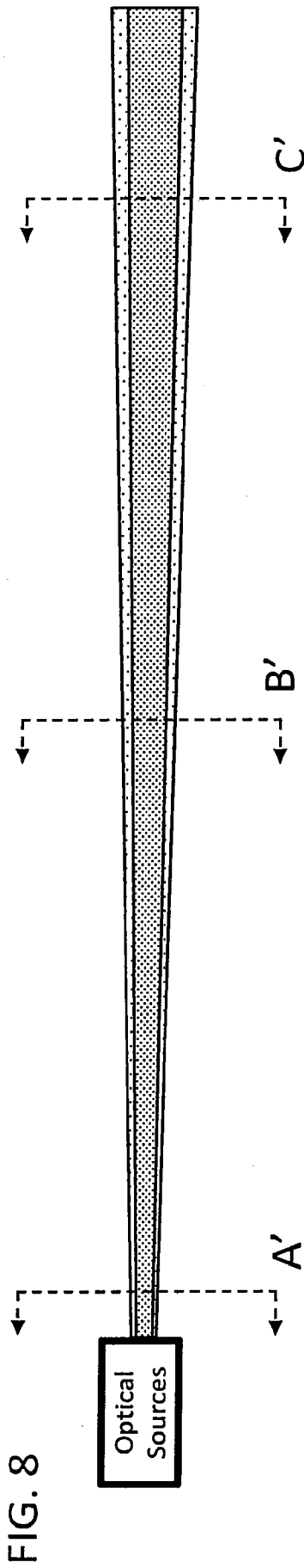

FIG. 8

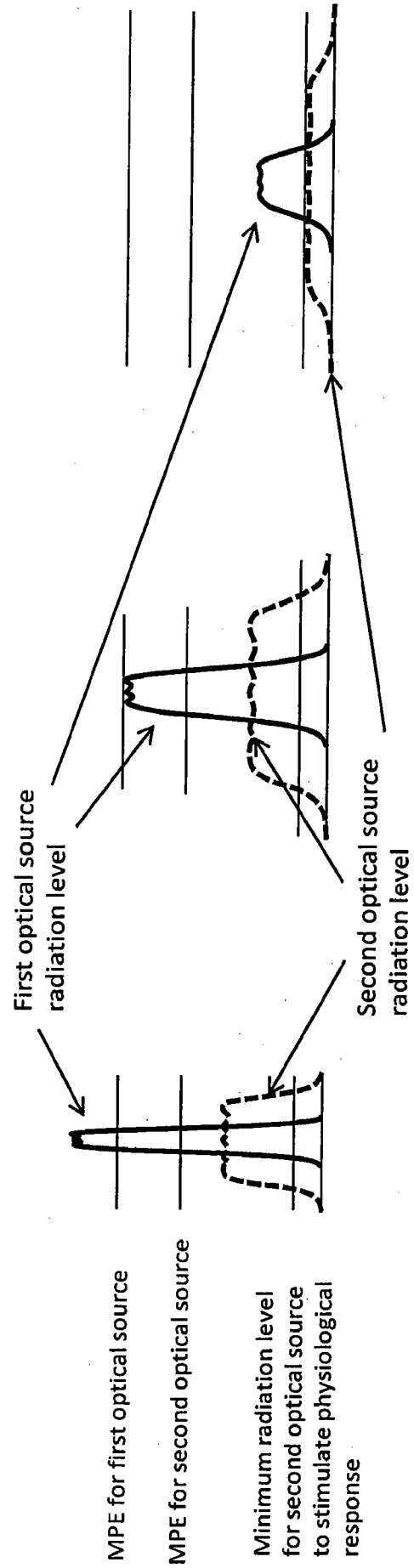

FIG. 8C

FIG. 8B

FIG. 8A

7/18

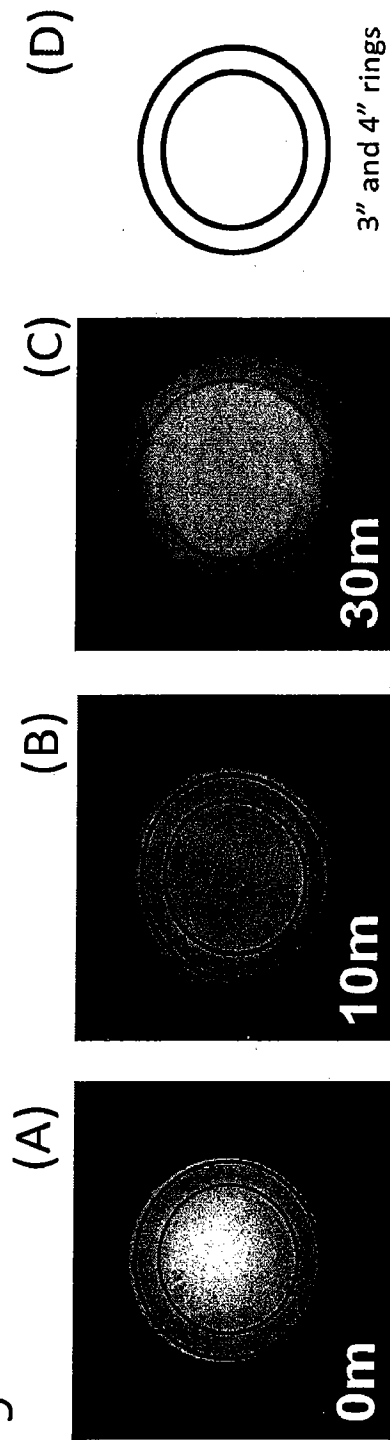

FIG. 9

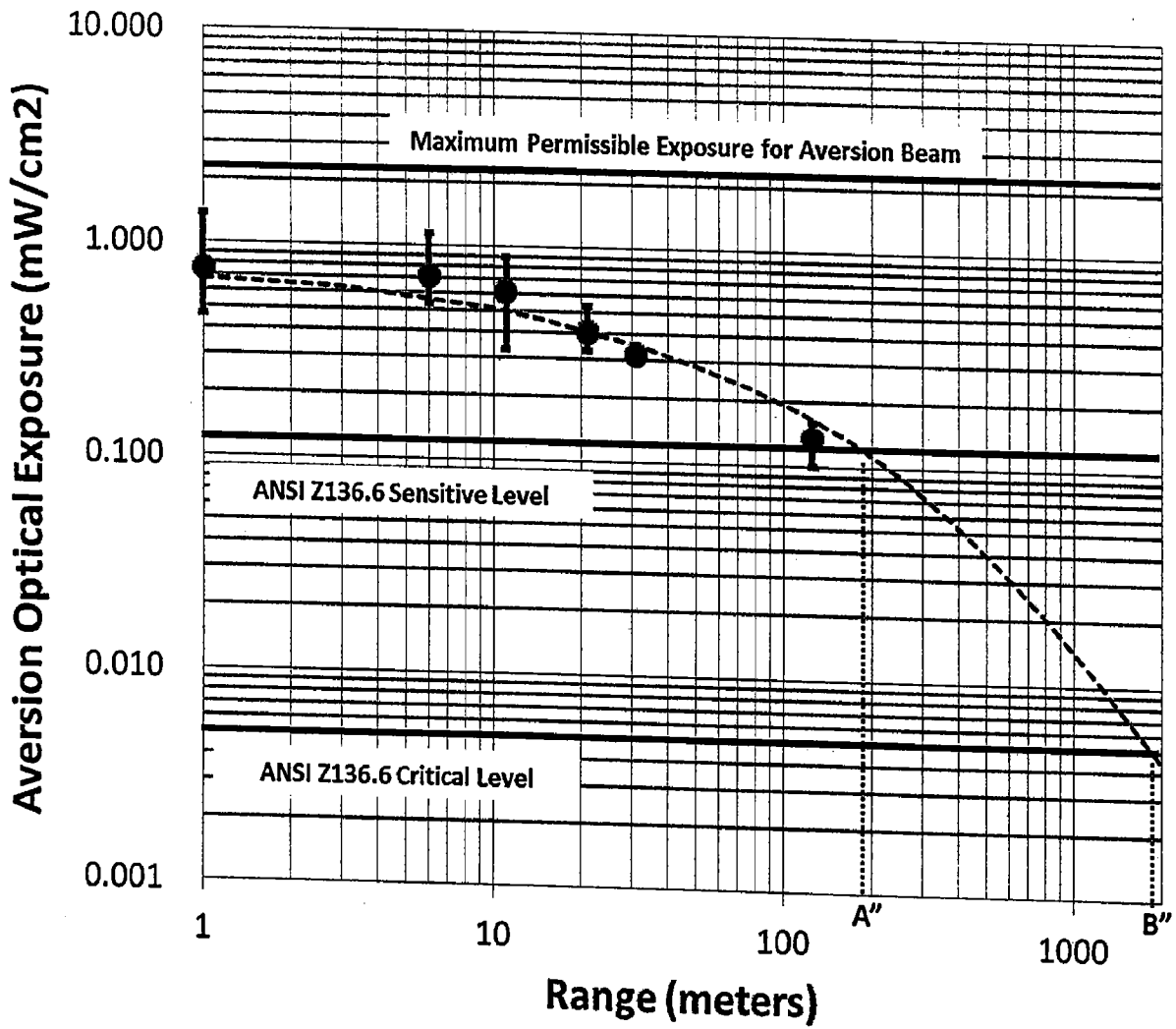

FIG. 10

9/18

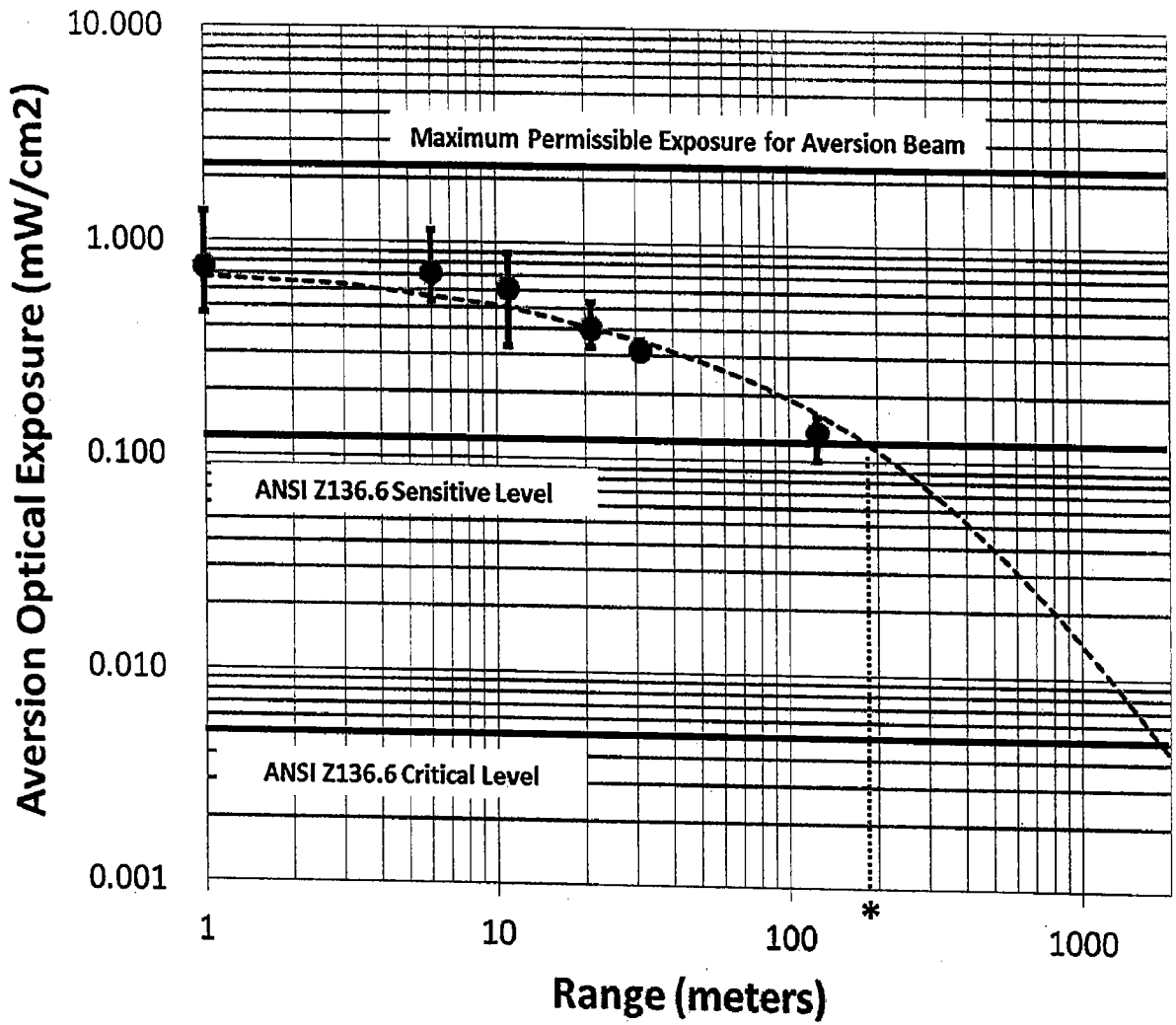

FIG. 11

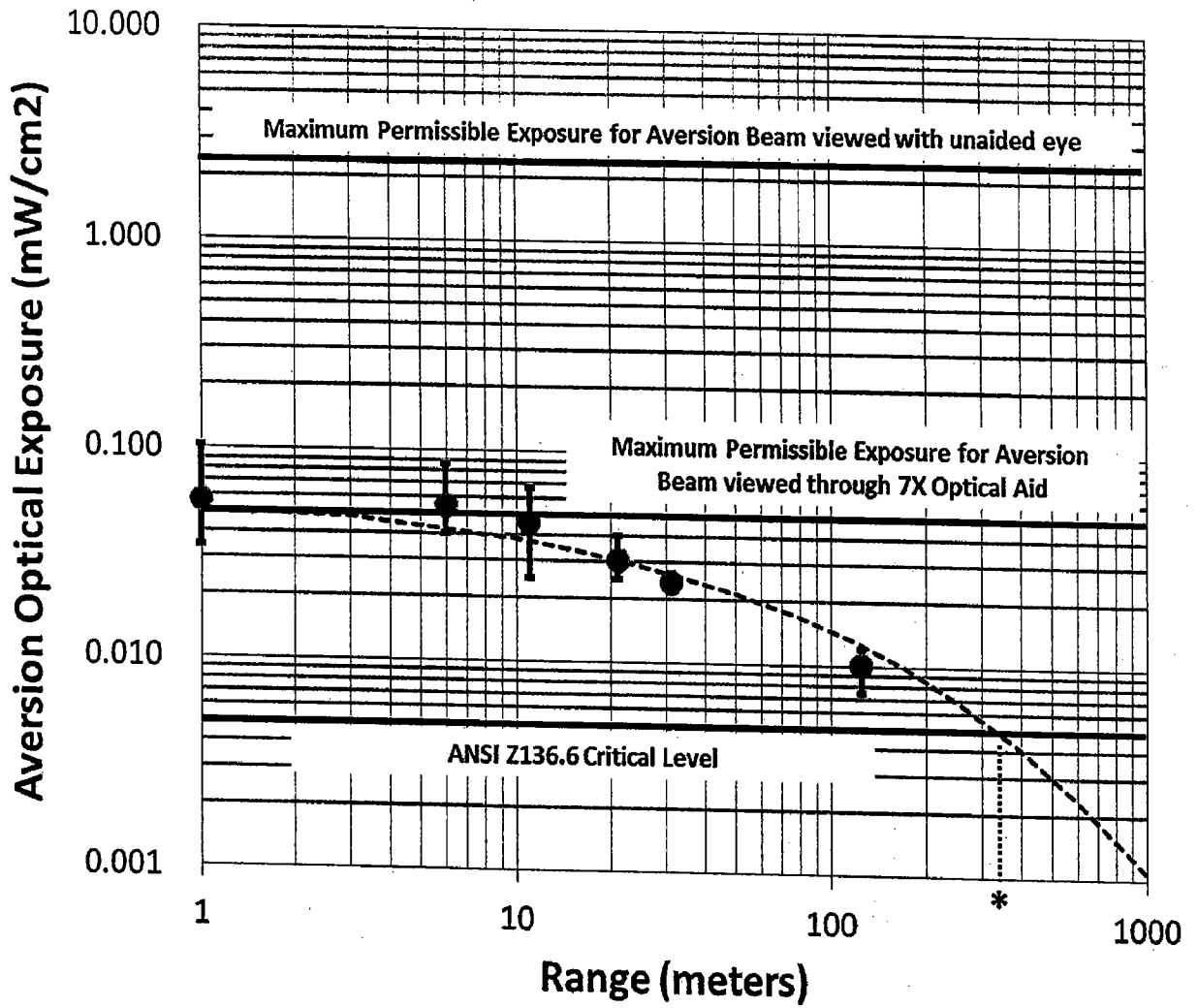

FIG. 12

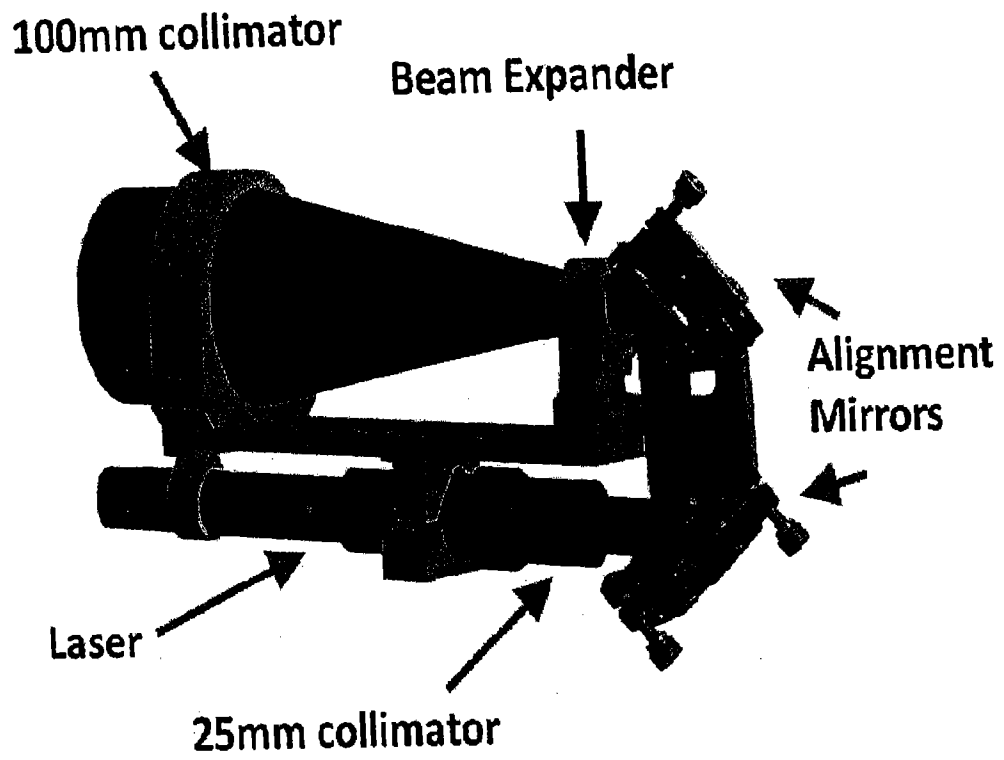

FIG. 13

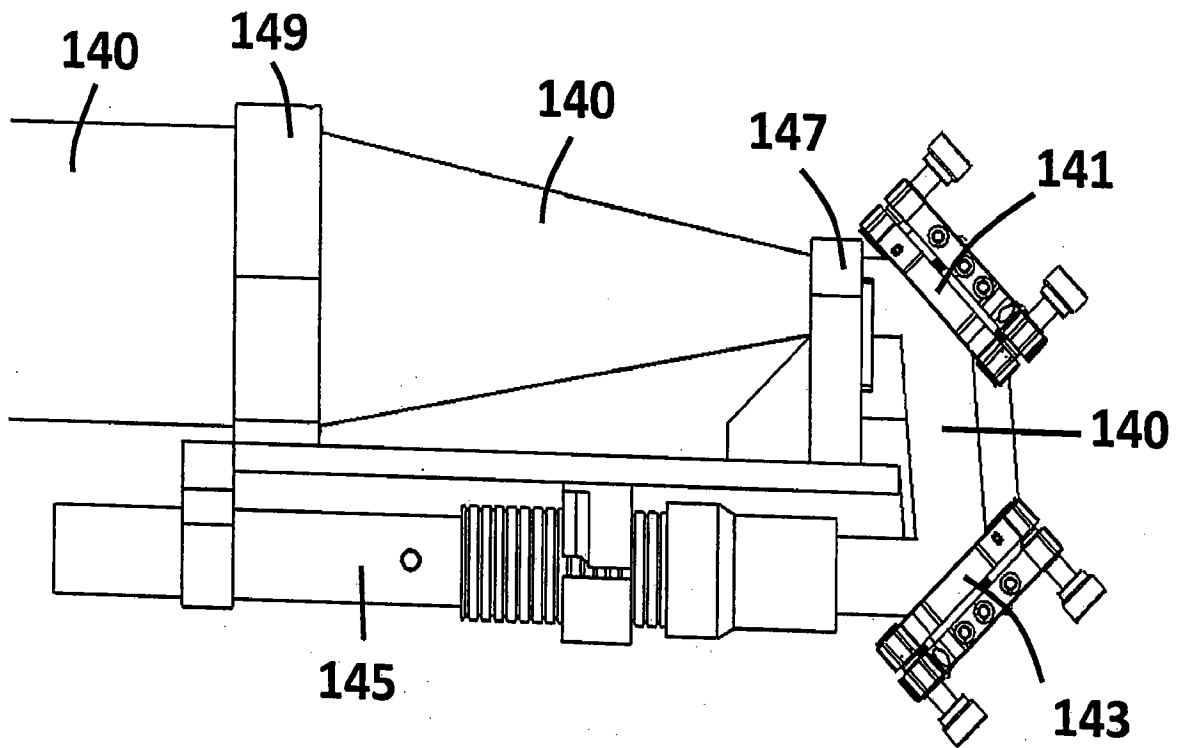

FIG. 14



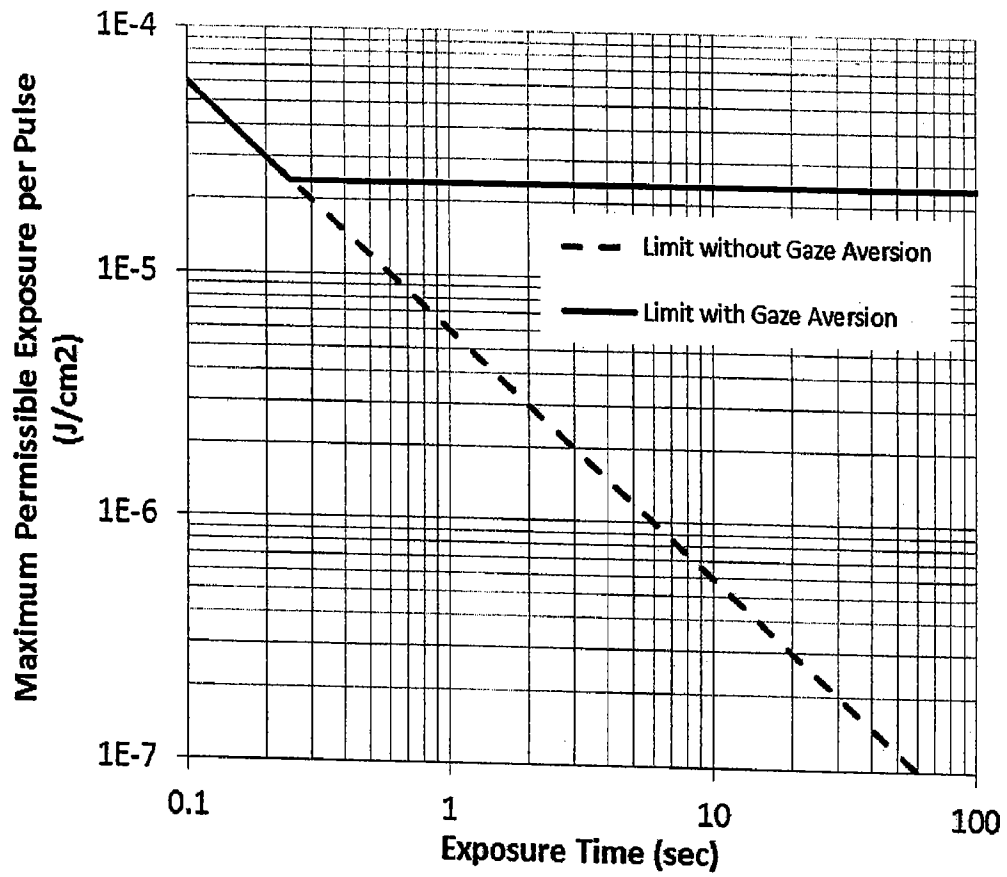

FIG. 16

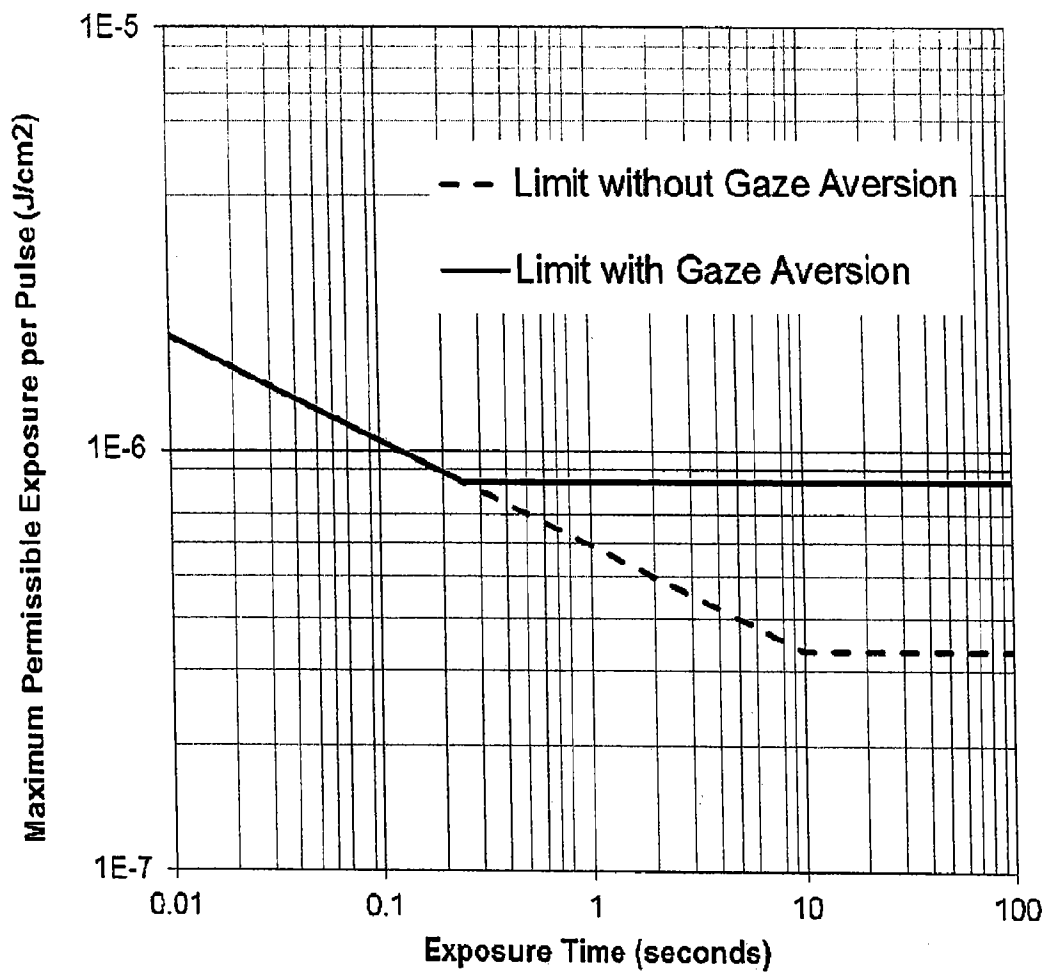

FIG. 17

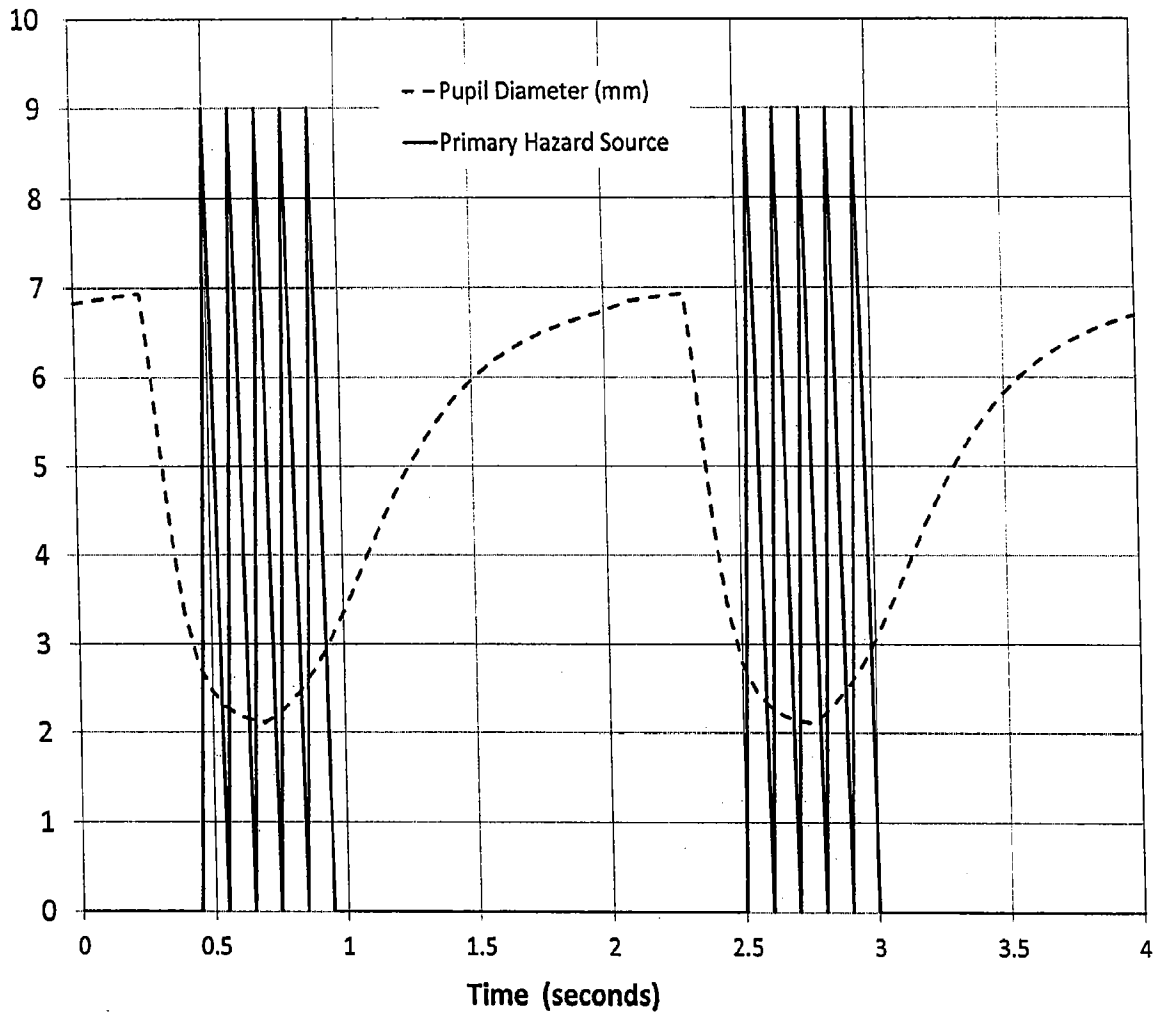

FIG. 18

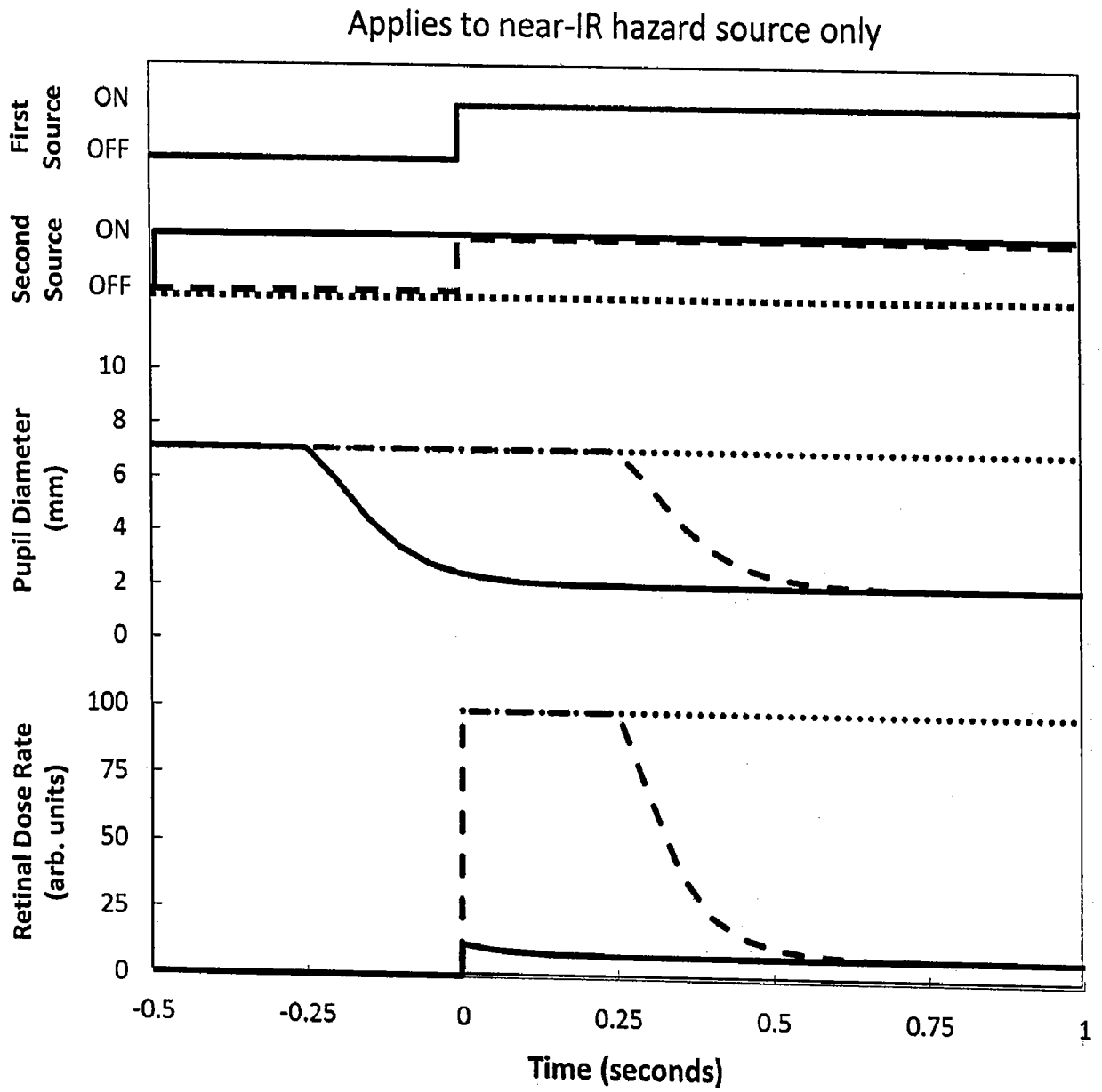

FIG. 19

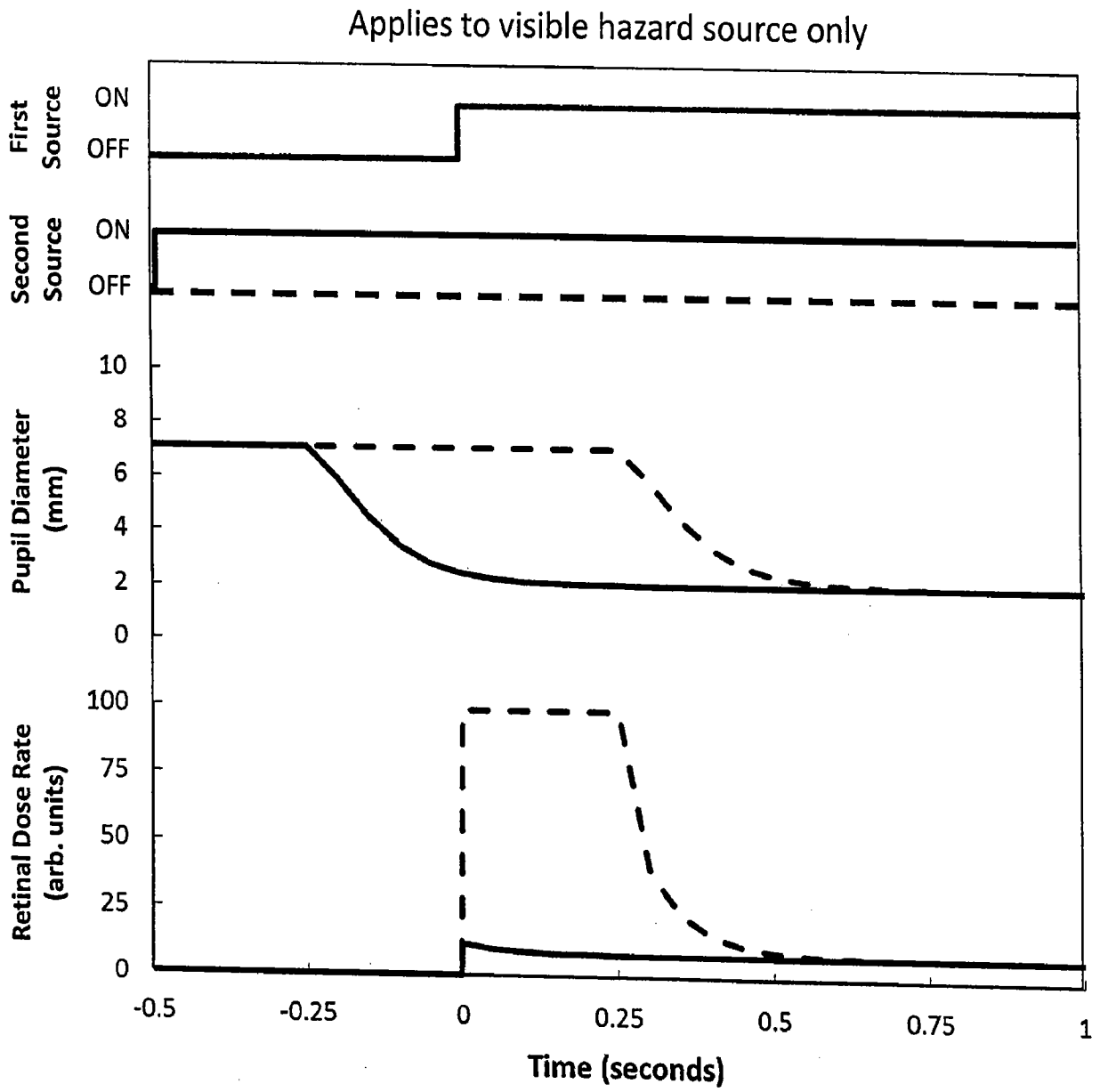

FIG. 20

**A. CLASSIFICATION OF SUBJECT MATTER***G01N 21/65(2006.01)i, G01N 21/33(2006.01)i*

According to International Patent Classification (IPC) or to both national classification and IPC

**B. FIELDS SEARCHED**

Minimum documentation searched (classification system followed by classification symbols)

G01N 21/65; G08G 5/04; G01N 21/27; G01N 15/02; G01J 3/00; G01N 21/00; G01N 21/59; G01C 3/08

Documentation searched other than minimum documentation to the extent that such documents are included in the fields searched

Korean utility models and applications for utility models

Japanese utility models and applications for utility models

Electronic data base consulted during the international search (name of data base and, where practicable, search terms used)

eKOMPASS(KIPO internal) &amp; Keywords:laser, optical, hazard, mirror, attenuate, diverge, collimate, superimpose

**C. DOCUMENTS CONSIDERED TO BE RELEVANT**

Category*	Citation of document, with indication, where appropriate, of the relevant passages	Relevant to claim No.
A	US 2006-0238757 A1 (SILCOTT, DAVID) 26 October 2006 See the abstract, paragraphs [0038] - [0044], and figs.9-11.	1-22
A	US 6208270 B1 (DUNN, MURRAY) 27 March 2001 See the abstract, column 2, line 25 - line 53, column 3, line 49 - column 4, line 32, and figs.4,5	1-22
A	US 05946092 A (DEFREEZ, RICHARD K. et al.) 31 August 1999 See the abstract, column 5, line 43 - column 6, line 30, column 9, line 40 - column 10, line 29	1-22
A	US 7133123 B1 (LEI, JONATHAN S. et al.) 07 November 2006 See the abstract, figs. 2-5.	1-22
A	US 04945239 A (WIST, ABUND O. et al.) 31 July 1990 See the abstract, figs.5-7,11.	1-22
A	US 2008-0192232 A1 (NINOMIYA, HIDEKI et al.) 14 August 2008 See the abstract, fig.1.	1-22

 Further documents are listed in the continuation of Box C. See patent family annex.

\* Special categories of cited documents:

"A" document defining the general state of the art which is not considered to be of particular relevance

"E" earlier application or patent but published on or after the international filing date

"L" document which may throw doubts on priority claim(s) or which is cited to establish the publication date of citation or other special reason (as specified)

"O" document referring to an oral disclosure, use, exhibition or other means

"P" document published prior to the international filing date but later than the priority date claimed

"T" later document published after the international filing date or priority date and not in conflict with the application but cited to understand the principle or theory underlying the invention

"X" document of particular relevance; the claimed invention cannot be considered novel or cannot be considered to involve an inventive step when the document is taken alone

"Y" document of particular relevance; the claimed invention cannot be considered to involve an inventive step when the document is combined with one or more other such documents, such combination being obvious to a person skilled in the art

"&amp;" document member of the same patent family

Date of the actual completion of the international search

11 OCTOBER 2012 (11.10.2012)

Date of mailing of the international search report

**12 OCTOBER 2012 (12.10.2012)**

Name and mailing address of the ISA/KR

Korean Intellectual Property Office  
189 Cheongsu-ro, Seo-gu, Daejeon Metropolitan  
City, 302-701, Republic of Korea

Facsimile No. 82-42-472-7140

Authorized officer

CHOI, Hyun Goo

Telephone No. 82-42-481-8434



**INTERNATIONAL SEARCH REPORT**

Information on patent family members

International application No.

**PCT/US2012/037679**

Patent document cited in search report	Publication date	Patent family member(s)	Publication date
US 2006-0238757 A1	26.10.2006	None	
US 6208270 B1	27.03.2001	None	
US 05946092 A	31.08.1999	US 06137572A A WO 1999-46577 A1	24.10.2000 16.09.1999
US 7133123 B1	07.11.2006	None	
US 04945239 A	31.07.1990	None	
US 2008-0192232 A1	14.08.2008	CA 2518491 A1 CA 2534527 A1 DE 602004032443 D1 EP 1602918 A1 EP 1653221 A1 EP 1653221 A4 EP 1653221 B1 JP 03-783019 B2 JP 03-830050 B2 JP 2004-294423 A JP 2005-091343 A KR 10-1126951 B1 KR 20060034299A US 2006-0238741 A1 US 7385681 B2 US 7505126 B2 WO 2004-079350 A1 WO 2005-015183 A1	16.09.2004 17.02.2005 09.06.2011 07.12.2005 03.05.2006 30.12.2009 27.04.2011 07.06.2006 04.10.2006 21.10.2004 07.04.2005 20.03.2012 21.04.2006 26.10.2006 10.06.2008 17.03.2009 16.09.2004 17.02.2005