

(19) **DANMARK**

(10) **DK/EP 3328546 T3**



(12) **Oversættelse af
europæisk patentskrift**

Patent- og
Varemærkestyrelsen

-
- (51) Int.Cl.: **B 02 C 17/16 (2006.01)**
- (45) Oversættelsen bekendtgjort den: **2024-07-15**
- (80) Dato for Den Europæiske Patentmyndigheds bekendtgørelse om meddelelse af patentet: **2024-04-10**
- (86) Europæisk ansøgning nr.: **16829910.5**
- (86) Europæisk indleveringsdag: **2016-07-27**
- (87) Den europæiske ansøgnings publiceringsdag: **2018-06-06**
- (86) International ansøgning nr.: **FI2016050545**
- (87) Internationalt publikationsnr.: **WO2017017315**
- (30) Prioritet: **2015-07-28 AU 2015903008**
- (84) Designerede stater: **AL AT BE BG CH CY CZ DE DK EE ES FI FR GB GR HR HU IE IS IT LI LT LU LV MC MK MT NL NO PL PT RO RS SE SI SK SM TR**
- (73) Patenthaver: **Metso Finland Oy, Rauhalanpuisto 9, 02230 Espoo, Finland**
Swiss Tower Mills Minerals AG, Haselstrasse 1, 5400 Baden, Schweiz
- (72) Opfinder: **HEATH, Alex, Unit 2, 3 Kitchener Road, Melville, Western Australia 6156, Australien**
BELKE, Jeffrey, Victor, 11 Cowrie Crescent, Mt Pleasant, Western Australia 6153, Australien
JAMIESON, Edward, Allan, 104 Leake Street, Bayswater, Western Australia 6053, Australien
- (74) Fuldmægtig i Danmark: **AWA Denmark A/S, Strandgade 56, 1401 København K, Danmark**
- (54) Benævnelse: **FORBEDRINGER I FORMALINGSMØLLER**
- (56) Fremdragne publikationer:
WO-A1-2013/167851
CN-U- 203 816 714
DE-U1-202008 006 745
DE-U1-202014 102 338
GB-A- 1 000 040
JP-A- 2001 046 899
JP-B1- 3 945 717
US-A- 3 307 792
US-A- 3 533 566
US-A- 4 174 074
US-A- 6 158 680
US-A1- 2010 170 972
US-A1- 2013 233 953

DESCRIPTION

Description

Field of the Invention

[0001] The invention relates to improvements in grinding mills and in particular to a stirring device for a grinding mill, stirring device assembly, mill body, grinding mill and method for grinding particulate material. The invention has been developed primarily for use in a fine grinding mill for grinding mineral ore particles. However, it will be appreciated that the invention is applicable in the grinding of other particulate material, such as concrete, cement, recyclable materials (such as glass, ceramics, electronics and metals), food, paint pigments, abrasives and pharmaceutical substances.

Background of the Invention

[0002] Grinding mills are typically used in mineral processing to grind mineral ore particles into smaller sized particles to facilitate further downstream processing, such as separation of the valuable mineral particles from unwanted gangue. One type of grinding mill is a fine grinding mill for grinding mineral ore particles in the range of about 30 μ m to 4000 μ m in diameter down to particles of 5 to 40 μ m in diameter. As fine grinding mills consume a large amount of power per tonne of ore processed, they are typically used on a concentrate stream comprising mostly of a high-grade mineral ore that has already been ground using a ball or SAG type grinding mill that performs coarse grinding as it is more economic.

[0003] The fine grinding mill has a stationary mill body or shell arranged vertically in the mill and an internal drive shaft. The drive shaft has a plurality of stirring elements, such as grinding discs, so that rotation of the drive shaft also rotates the stirring elements, which in turn rotates or stirs the mineral ore particles, usually in the form of a feed slurry, with a suitable grinding media. The resulting stirring action causes the mineral ore particles to be ground into smaller sized particles. However, the grinding discs tend to suffer from excessive wear, especially when the grinding mill is operated at high speeds through the action of the harder grinding media impacting against the grinding discs. US-6158680-A discloses an example of a grinding mill comprising stirring elements. The mill disclosed in US-3307792-A comprises additionally shelves extending from an inner sidewall.

Summary of the Invention

[0004] According to the invention, there is provided a stirring device defined in claim 1 and a mill body defined in claim 11.

[0005] A first aspect of the present invention provides a stirring device for stirring a particulate material and a grinding media in a grinding mill, comprising one or more protective elements that extend outwardly from a body to deflect said particulate material and said grinding media from said body.

[0006] Preferably, said one or more protective elements comprise a deflection surface, said deflection surface being arranged at an angle to a direction of rotation of said body. More preferably, said deflection surface is at an angle in the range of 10° to 170°, preferably 20° to 160°, preferably 30° to 150°, preferably 40° to 130°, preferably 50° to 120°, preferably 60° to 110°, more preferably 70° to 100°, even more preferably 80° to 95°, and most preferably 85° to 90°. In one embodiment, said deflection surface is orthogonal to the direction of rotation of said body.

[0007] Preferably, said one or more protective elements extend at an angle to a surface of said body. More preferably, said angle is in the range of 10° to 170°, preferably 20° to 160°, preferably 30° to 150°, preferably 40° to 130°, preferably 50° to 120°, preferably 60° to 110°, more preferably 70° to 100°, even more preferably 80° to 95°, and most preferably 85° to 90°. In one embodiment, said one or more protective elements extend orthogonally from said surface. In some embodiments, said body surface is a planar surface. In other embodiments, said body surface is a non-planar surface.

[0008] According to the first aspect, said body comprises an outer edge, wherein said one or more protective elements extend from said outer edge. More particularly, said one or more protective elements extend radially from said outer edge.

[0009] According to the first aspect, said body comprises opposed surfaces and said one or more protective elements extend from at least one of said opposed surfaces. More particularly, said one or more protective elements extend from each of said opposed surfaces.

[0010] According to the first aspect, there is a plurality of said protective elements, said protective elements being spaced apart around said body. Preferably, said protective elements are spaced apart at regular intervals. In one embodiment, said protective elements are spaced apart at irregular or uneven intervals. In a further embodiment, some of said protective elements are spaced apart at regular intervals on one portion of said body and other of said protective elements are spaced apart at irregular intervals on another portion of said body.

[0011] Preferably, said body comprises an annular shape. According to the first aspect, said body comprises an annular disc. Preferably, said opposed surfaces are planar surfaces. In one embodiment, said outer edge is an outer circumferential edge of said annular disc. In some embodiments, said annular disc has a diameter in the range of 250mm to 3000mm, preferably

300mm to 2750mm and most preferably 400mm to 2500mm.

[0012] The one or more protective elements can be configured into different shapes. Preferably, said one or more protective elements each comprise at least one or more of a projection, an elongated body, a block-shaped element, a flange, a tooth, a planar element, a vane, a blade, a fin, a plate, a bar, a post, a rod, a channel-shaped element, a V-shaped element, a U-shaped element, a depression, a recess, a ramp-like element and a wedge-shaped element.

[0013] Preferably, said one or more protective elements are substantially linear in shape. Alternatively, one or more protective elements have a non-linear configuration. For example, the protective element(s) may be helical, spiral, sinuous or curved, in whole or part.

[0014] Where said one or more protective elements comprise said block-shaped element, said block-shaped element is preferably connected to said planar body so that opposed sides of said block-shaped element extend outwardly from said opposed surfaces of said planar body. In one embodiment, said block-shaped element comprises an outer end that extends radially outwardly from an outer edge of said planar body. In some embodiments, said block-shaped element is integrally formed with said planar body. In other embodiments, said block-shaped element is U-shaped for mounting to said planar body.

[0015] Preferably, where said one or more protective elements comprise said planar element, said planar element is inclined relative to the said planar body. In one embodiment, said planar element is inclined towards a direction of rotation of said stirring device. In another embodiment, said planar element is inclined away from a direction of rotation of said stirring device.

[0016] Preferably, said planar element comprises a vane, blade, planar tooth or plate.

[0017] Preferably, said one or more protective elements are integrally formed with said body.

[0018] A second aspect of the present invention provides the use of the stirring device of the first aspect of the invention in a stirring device assembly.

[0019] A third aspect of the present invention provides a stirring device assembly for stirring a particulate material and a grinding media in a grinding mill, comprising a plurality of stirring devices of the first aspect of the invention mounted to a drive shaft for rotating said stirring devices.

[0020] Preferably, said stirring devices are spaced apart along the length of said drive shaft.

[0021] Preferably, said drive shaft comprises one or more of protective elements extending radially from said drive shaft. More preferably, said protective elements have the same features as the preferred features of the one or more protective elements of the first aspect of

the invention.

[0022] A fourth aspect of the present invention provides the use of the stirring device assembly of the third aspect of the invention as a mill impeller in a grinding mill.

[0023] A fifth aspect of the present invention provides a drive shaft assembly for stirring a particulate material and a grinding media in a grinding mill, comprising a drive shaft and a plurality of protective elements for deflecting said particulate material and said grinding media from said drive shaft.

[0024] Preferably, said protective elements are spaced apart along the length of said drive shaft.

[0025] Preferably, at least two of said protective elements extend from either side of said drive shaft. In one embodiment, said protective elements extend radially outwardly from said drive shaft. In some embodiments, said protective elements are arranged around the circumference of said drive shaft.

[0026] Preferably, said protective elements have the same features as the preferred features of the protective elements of the first aspect of the invention, where applicable. For example, the protective elements also preferably have a deflection surface as in the first aspect of the invention, but which is arranged at angle to the direction of rotation of the drive shaft and not a stirring device body. In this case, the preferred ranges of the angle are the same, including providing the deflection surface substantially orthogonal to the direction of rotation of the drive shaft. Likewise, the protective elements may also extend at an angle, but with respect to the direction of rotation of the drive shaft and not a stirring device body. In one particularly preferred embodiment, said protective elements have a planar or non-curved deflection surface.

[0027] A sixth aspect of the present invention provides the use of the drive shaft assembly of the fourth aspect of the invention as a mill impeller in a grinding mill.

[0028] A seventh aspect of the present invention provides a mill body comprising the stirring device assembly of the third aspect of the invention or the drive shaft assembly of the fourth aspect of the invention.

[0029] Preferably, said mill body further comprises an inlet for receiving a particulate material and an outlet for discharging ground particles.

[0030] Preferably, said mill body comprises one or more shelves extending from an inner sidewall, said one or more shelves define one or more chambers containing said stirring devices or said protective elements, and openings communicating between said chambers.

[0031] Preferably, said one or more shelves alternate between said one or more stirring

devices or said protective elements.

[0032] Preferably, said mill body is arranged vertically in said mill. In some embodiments, said mill body is arranged at an angle in said mill. In other embodiments, said mill body is arranged horizontally in said mill.

[0033] Preferably, said inlet is at the bottom of said mill body and said inlet is at the top of said mill body.

[0034] An eighth aspect of the present invention provides a grinding mill comprising the mill body of the seventh aspect of the invention.

[0035] Preferably, said grinding mill is a fine grinding mill. More preferably, said fine grinding mill has a power consumption of 10 to 70 kilowatt hours per tonne (kWhr/t). In one preferred embodiment, said fine grinding mill has a power consumption of 30kWhr/t.

[0036] A ninth aspect of the present invention provides a mill body for grinding a particulate material comprising an inlet for receiving said particulate material, an outlet for discharging ground particles and a shelf extending from an inner sidewall, said shelf comprising one or more protective elements that extend outwardly from said shelf to deflect said particulate material and said grinding media said shelf.

[0037] According to the ninth aspect, said one or more protective elements extend radially from said shelf.

[0038] According to the ninth aspect, said shelf comprises opposed surfaces and said one or more protective elements extend from at least one of said opposed surfaces. More particularly, said one or more protective elements extend from each of said opposed surfaces.

[0039] Preferably, said one or more protective elements extend orthogonally from at least one of said opposed surfaces. More preferably, said one or more protective elements extend orthogonally from each of said opposed surfaces.

[0040] According to the ninth aspect, there is a plurality of said protective elements, said protective elements being spaced apart around said shelf. In one embodiment, said protective elements are spaced apart at regular intervals. In another embodiment, said protective elements are spaced apart at uneven or regular intervals.

[0041] Preferably, said one or more protective elements of the sixth aspect have the same features as the preferred features of the one or more protective elements of the first aspect of the present invention, where applicable.

[0042] Preferably, said shelf is annular in shape. In some embodiments, said shelf is angled relative to the inner sidewall. In other embodiments, said shelf is a static counter disc.

[0043] A tenth aspect of present invention provides a grinding mill comprising the mill body of the ninth aspect of the invention, a drive shaft and a plurality of stirring elements mounted to said drive shaft.

[0044] Preferably, the grinding mill of the ninth aspect has the preferred features of the eighth aspect of the invention, where applicable.

[0045] An eleventh aspect of the present invention provides a method of grinding a particulate material in a grinding mill of the type having a mill body and a drive shaft for rotating a plurality of stirring devices within said mill body, said method comprising:

introducing grinding media into said mill body;

introducing said particulate material through an inlet; and

operating said drive shaft to rotate said stirring devices within said mill body;

wherein said rotation of said stirring devices induces a rotating flow of said particulate material within said mill body to grind said particulate material against said grinding media to produce smaller sized particles; and

wherein one or more protective elements deflect said particulate material and said grinding media away from said stirring devices.

[0046] Preferably, said method comprises creating a zone around said stirring devices where said grinding media is captured by said one or more protective elements and rotated with said stirring devices.

[0047] Preferably, said method comprises arranging said one or more protective elements at an angle to a direction of rotation of said stirring devices.

[0048] Preferably, said one or more protective elements comprise a deflection surface, said method comprising arranging said deflection surface at an angle to a direction of rotation of said stirring devices.

[0049] Preferably, said angle is in the range of 10° to 170°, preferably 20° to 160°, preferably 30° to 150°, preferably 40° to 130°, preferably 50° to 120°, preferably 60° to 110°, more preferably 70° to 100°, even more preferably 80° to 95°, and most preferably 85° to 90°. In one embodiment, said method comprising arranging said deflection surface orthogonally to the direction of rotation.

[0050] Preferably, said method comprises locating said one or more protective elements adjacent said stirring devices. In some embodiments, said one or more protective elements

extend from said stirring devices. In other embodiments, said one or more protective elements extend from a shelf extending from an inner sidewall of said mill body.

[0051] A twelfth aspect of the present invention provides a method of grinding a particulate material in the grinding mill of the type having a mill body and a drive shaft assembly comprising a plurality of protective elements extending from a drive shaft, said method comprising:

introducing grinding media into said mill body;

introducing said particulate material through an inlet; and

operating said drive shaft to rotate said drive shaft assembly within said mill body;

wherein said rotation of said drive shaft assembly induces a rotating flow of said particulate material within said mill body to grind said particulate material against said grinding media to produce smaller sized mineral particles; and

wherein said protective elements deflect said particulate material and said grinding media away from said drive shaft.

[0052] Preferably, said particulate material comprises mineral particles. More preferably, said mineral particles have a F80 of 30 μ m to 4000 μ m, preferably 35 μ m to 3000 μ m, preferably 40 μ m to 2000 μ m, preferably 45 μ m to 1500 μ m, even more preferably 50 μ m to 1000 μ m, preferably 60 μ m to 750 μ m, further preferably 65 μ m to 500 μ m, further more preferably 70 μ m to 400 μ m, even more preferably 75 μ m to 300 μ m and most preferably 80 μ m to 200 μ m.

[0053] Preferably, wherein said smaller sized mineral particles have a P80 of 0.1 μ m to 1000 μ m, preferably 0.25 μ m to 750 μ m, preferably 0.3 μ m to 500 μ m, preferably 0.4 μ m to 400 μ m, preferably 0.5 μ m to 300 μ m, preferably 0.6 μ m to 250 μ m, preferably 0.7 μ m to 200 μ m further preferably 0.75 μ m to 150 μ m, further more preferably 0.8 μ m to 100 μ m, even more preferably 0.9 μ m to 75 μ m and most preferably 1 μ m to 50 μ m.

[0054] Preferably, wherein said particulate material comprises mineral particles. More preferably, said mineral particles are mineral ore particles having a density of at least 2,000 kg/m³. In some embodiments, said mineral ore particles comprises at least one of iron, quartz, copper, nickel, zinc, lead, gold, silver, platinum, tungsten, chromium, silicon and combinations thereof.

[0055] Preferably, said particulate material comprises at least one of concrete, cement, recyclable material, pharmaceutical substances, paint pigment, abrasives and food. In some embodiments, said recyclable material comprises at least one of glass, ceramics, electronics and metals.

[0056] The methods of the tenth and eleventh aspects of the invention have the preferred features of any previous aspect of the invention, where applicable. In particular, said protective elements have the preferred features of the first aspect of the invention, where applicable.

[0057] Unless the context clearly requires otherwise, throughout the description and the claims, the words "comprise", "comprising", and the like are to be construed in an inclusive sense as opposed to an exclusive or exhaustive sense; that is to say, in the sense of "including, but not limited to".

[0058] Furthermore, as used herein and unless otherwise specified, the use of the ordinal adjectives "first", "second", "third", etc., to describe a common object, merely indicate that different instances of like objects are being referred to, and are not intended to imply that the objects so described must be in a given sequence, either temporally, spatially, in ranking, or in any other manner.

Brief Description of the Drawings

[0059] Preferred embodiments of the invention will now be described, by way of example only, with reference to the accompanying drawings in which:

Figure 1 is a perspective view of a grinding mill having a stirring device assembly comprising a plurality of stirring devices according to an embodiment of the invention;

Figure 2 is a front view of the grinding mill of Figure 1;

Figure 3 is a side view of the grinding mill of Figure 1;

Figure 4 is a rear view of the mill body used in the grinding mill of Figure 1;

Figure 5 is a cross-sectional view of the mill body of Figure 4;

Figure 6 is a partial cross-sectional perspective view of the mill body of Figure 4;

Figure 7 is a partial cross-sectional view of the mill body of Figure 4 at the mounting ring indicated by area A in Figure 5;

Figure 8 is a top view of the mill body of Figure 4;

Figure 9 is a perspective view of a stirring device in the stirring device assembly used in the mill body of Figure 1;

Figure 10 is a side view of the stirring device of Figure 9;

Figure 11 is a cross-sectional view of the stirring device of Figure 9;

Figures 12A to 12G are partial perspective views of stirring devices according to other embodiments of the invention;

Figures 13A to 13E are partial perspective views of stirring devices and drive shaft assemblies not forming part of the invention;

Figure 14 is a partial cross-sectional view of a mill body according to another embodiment of the invention; and

Figure 15 is a partial cross-sectional view of a mill body according to another embodiment of the invention.

Preferred Embodiments of the Invention

[0060] The present invention will now be described with reference to the following examples which should be considered in all respects as illustrative and non-restrictive. In the Figures, corresponding features within the same embodiment or common to different embodiments have been given the same reference numerals. Referring to Figures 1 to 3, a grinding mill 1 for grinding a slurry having particulate material comprises a mill body 2 mounted on a base frame 3 and a drive mechanism 4 mounted on a drive frame 5 for rotating the mill body 3 about a longitudinal axis 6.

[0061] In this embodiment, the mill body 2 is arranged vertically in the grinding mill 1 and has a bottom inlet 7 and a top outlet 8. It will be appreciated that in other embodiments, the mill body 2 is arranged to be inclined or at an angle in the grinding mill 1. In some embodiments, the mill body 2 is arranged to lie horizontally in the grinding mill 1. Likewise, in other embodiments, the inlet 7a and outlet 8 can be placed at locations of the mill body 2 other than the bottom and top, respectively.

[0062] A charge of feed slurry comprising mineral ore particles is fed into the mill body 2 through the bottom inlet 7. Grinding media M is also added into the mill body 2 initially through the outlet 8 before the feed slurry is added and grinding mill 1 is in operation. Once the grinding mill 1 is in operation, the initial charge of grinding media M tends to wear out due to the grinding process. Accordingly, grinding media M is also progressively added with the feed slurry through the inlet 7 as the grinding mill 1 operates. The grinding media M typically comprises ceramic or steel beads that range from 1mm to 5mm in diameter. The size of the grinding media M may vary in other embodiments, depending on requirements. For example, the diameter of the grinding media can be 30 or 50 times the diameter of the slurry particles, which can be measured by reference to F80 or F100, which is discussed in more detail below. The mill body 2 is rotated by the drive mechanism 4 about the axis 6 to rotate or stir the feed slurry and grinding media together, causing the feed slurry particles to be crushed or ground against between the grinding media. The ground product is then discharged through the top outlet 8.

[0063] Referring to Figures 4 to 8, the mill body 2 comprises a mounting assembly 9 for fitting the mill body to the base frame 3 and operatively aligning the mill body to the drive mechanism 4. The mounting assembly 9 comprises a support gusset 9a and a mounting hinge 9b. The mill body 2 also comprises a stirring device assembly 10 comprising a drive shaft 11 to which are mounted a plurality of stirring devices 12 described in more detail below. In this embodiment, the stirring device assembly 10 takes the form of an impeller, but is also known as a drive shaft assembly. As such, the stirring device assembly will hereinafter be referred to as a mill impeller in reference to this embodiment.

[0064] An internal side wall 13 of the mill body 2 has a plurality of planar annular shelves 14 extending into the internal cavity 15 between the stirring devices 12 to subdivide the mill body 2 so that the feed slurry flows upwardly from the bottom inlet 7 through openings 16 and eventually is discharged from the top outlet 8 after grinding. The shelves 14 tend to subdivide the internal cavity 15 into individual chambers 17. In this embodiment, the grinding mill 1 is a fine grinding mill, and is called a high intensity grinding mill, in which the rotating action of the stirring devices 12 results in intense grinding of the slurry particles by the grinding media M occurring in the cavity 15 adjacent the stirring devices. Fine grinding mills have a relatively high power consumption in order to achieve fine grinding, in the range from 10 kWhr/t to 70 kWhr/t (kilowatt hours per tonne). In this embodiment, the fine grinding mill has a power consumption of 30 kWhr/t.

[0065] Referring to Figures 9 to 11, the stirring devices 12 in the mill impeller 10 comprise a planar body 20 having opposed planar surfaces 21, 22 and an outer edge 23. In this embodiment, the planar body 20 is an annular disc but it will be appreciated that the planar body can take other forms in other embodiments, such as rectangular, square, oval or oval-like, circular and any other regular or irregular polygonal shape. It will be appreciated by one skilled in the art that for industrial duties the annular disc size ranges from 400mm diameter to 2500mm diameter. However, the invention applies equally to fine grinding discs of any size. Also, the stirring devices 12 can have surfaces other than two opposed surfaces, such as any number of surfaces that have the same or different shapes. For example, the stirring devices may have an inclined or angled surface, a curved surface, a corrugated surface, a saw-toothed surface, irregular surface or any other regular or irregular shape. For ease of reference, the stirring devices 12 and planar body 20 in this embodiment will hereinafter be referred to as grinding discs and disc body, respectively.

[0066] A plurality of protective elements 25 adjacent to the outer edge 23 extends outwardly from the disc body 20 to deflect the slurry particles and grinding media M. This effectively minimises or reduces the shear around the disc body 20 by minimising contact of the mixture of slurry particles and grinding media M against the disc body 20 and promoting contact between the slurry particles and grinding media. A mounting ring 28 is connected via arms 29 (typically known as spokes) to the disc body 20 for mounting each grinding disc 12 to the drive shaft 11 of the stirring device assembly 11. The protective elements 25 in this embodiment take the form of blocks or block-like elements that are integrally formed with the disc body 20 and arranged so that opposed sides 31, 32 and one end 33 of the blocks project outwardly from

the planar surfaces 21, 22 and outer edge 23, respectively. Each block 25 thus extends both substantially orthogonally relative to the opposed planar surfaces 21, 22 via its opposed sides 31, 32 and radially outwardly from the outer edge 23 via its end 33. Alternatively, the protective elements 25 are in the form of U-shaped blocks mounted to the disc body 20 so that opposed sides 31, 32 and one end 33 of each block 25 extends or projects outwardly from the planar surfaces 21, 22 and outer edge 23 of the disc body, respectively.

[0067] In operation, the drive mechanism 4 rotates the drive shaft 11 of the stirring device assembly 10, rotating the grinding discs 12 that in turn rotate the feed slurry and grinding media within the internal cavity 15 of the mill body 2. This rotation causes the feed slurry particles to be ground against and between the harder grinding media, thus releasing valuable mineral particles and reducing them in size for further downstream processing after being discharged through the outlet 8. The feed slurry particles may also be ground against the mill impeller 10. This grinding action occurs over a period of time and thus can be viewed as attrition of the slurry particles. In addition, the blocks 25 act to create a zone (relative to the motion of the grinding disc 12) around the outer circumferential edges 23 and the opposed surfaces 21, 22 of the disc body 20, promoting contact between the feed slurry particles and the grinding media M. In effect, a rotating pocket of material comprising the feed slurry and grinding media M is formed and "captured" in the zone that can be transported by the blocks 25. At the same time, the zone created by the blocks 25 minimises the amount of shear or slippage at the surfaces 21, 22 of the grinding discs 12, thus reducing the amount of wear on the grinding discs 12. That is, the protective elements 25 tend to move the slurry and the grinding media M away from the grinding discs 12. This means that there is less chance of shear or slippage being concentrated at the grinding discs 12. In addition, there is a lower probability of impacts occurring between the grinding media M and the grinding discs 12, and any impacts that do occur are not substantial but only minor in nature. Hence, the grinding discs 12 do not suffer excessive wear during operation of the mill body 2 in the grinding mill 1.

[0068] It is known by those skilled in the art that concentrated mineral ore slurries frequently act as non-Newtonian (shear thinning) fluids with a yield stress. This means that such slurries tend to act as a solid body and do not act as a fluid until sufficient force is applied (exceeding the yield stress), after which the viscosity drops dramatically. As a consequence, in a conventional grinding mill of the type that uses a series of stirring elements like grinding discs, the highest shear force is applied by the rotational torque at the lowest radius from the rotational centre due to the geometry of the rotating discs and drive shaft. This results in the non-Newtonian slurry material yielding and becoming fluid immediately adjacent to the drive shaft and grinding discs, with the rest of the slurry material remaining stationary, or close to stationary. This results in the shear or "slip" being concentrated right at the surface of the grinding discs, accelerating the amount of wear to the grinding discs. Accelerated wear of the grinding discs makes their operational life very short, thus requiring more frequent replacement than desired. The frequent replacement of the grinding discs also increases the amount of downtime, reducing the efficiency of the grinding mill, as well as increasing maintenance costs.

[0069] From this description of conventional fine grinding mills using stirring elements, the

technical advantages and benefits of the invention become apparent by way of contrast. In the embodiment of the invention, the zone around the outer edge 23 and the planar surfaces 21, 22 created by the blocks 25 alleviates or overcomes the above drawbacks and deficiencies that occur in conventional grinding mills. That is, the zone minimises or reduces the amount of wear on the grinding discs 12 by minimising the differential speed between the grinding media M and the grinding discs 12 (i.e. the amount of shear), prolonging their operational life. Consequently, there is less frequent replacement of the grinding discs 12, thus reducing maintenance costs and increasing grinding mill capacity due to there being less downtime for maintenance. By improving the amount or frequency of contact between the feed slurry particles and the grinding media M, the zone improves the efficiency of grinding in the grinding mill 1. Furthermore, the zone increases the amount of the feed slurry that acts as a fluid.

[0070] It will be appreciated that the protective elements 25 can take any number of forms in order to create the zone around each grinding disc 12. The protective elements 25 can be any form of projection that extends from the surfaces of the grinding disc 12, such as the upper planar surface 21, the lower planar surface 22, its outer edge 23 or any combination thereof. The protective element 25 can thus be planar, curved or adopt any polyhedral shape that protrudes for generating the zone. Some examples of possible shapes for the protective element 25 are illustrated in Figures 12A to 12G, 13A to 13E and discussed in more detail below. Aside from these specific examples, the protective elements 25 may comprise at least one or more of a protrusion, an elongated body, a flange, a tooth, a vane, a blade, a fin, a bar, a V-shaped element, a U-shaped element and a wedge-shaped element. However, it is preferred that the protective elements either extend or present a deflection surface that is at an angle so that they can gather or grip the slurry particles and grinding media M to deflect or move them away from the stirring device body. Hence, the most preferred implementation is to provide protective elements 25 that are orthogonal (i.e. 90°) to the direction of rotation of the stirring device 12 or slurry within the cavity 15.

[0071] Referring to Figures 12A and 12B, the protective element takes the form of a planar element that is a plate 35 that is inclined relative to the annular disc body 20. In Figure 12A, the plate 35 is inclined forward toward the direction of rotation 37 of the grinding disc 12. In Figure 12B, the plate 35 is inclined away from the direction of rotation 37 of the grinding disc 12. It will be appreciated that the planar element could take other forms other than the plate 25, such as a vane, a blade, a fin, or any other planar element.

[0072] In Figure 12C, the protective element takes the form of a channel 40 having two walls 42, 45 extending orthogonally to a base 48 mounted to the planar surface 21 of the annular disc body 20. In Figure 12D, the protective elements take the form of rectangular posts 50 extending radially from the outer edge 23 of the annual disc body 20. In other variations of this embodiment, the posts 50 can be cylindrical (i.e. a rod), hexagonal, oval or any other polygonal shape.

[0073] In Figure 12E, one of the protective elements takes the form of cylindrical posts or rods 55 extending substantially orthogonally from the planar surface 21 of the annular disc body 20.

In this embodiment, the rods 55 are aligned to be orthogonal to the outer edge 23. However, it will be appreciated that in other embodiments, the posts 55 need not be in alignment or be aligned but at an angle to the outer edge 23. Another of the protective elements takes the form of a ramp 60 having inclined sides 62, 63 and mounted to the planar surface 21 at its base 64.

[0074] Three different embodiments of the protective elements are illustrated in Figure 12F. One protective element takes the form of a depression or recess 65, which is concave in shape in this embodiment. In other forms, the depression or recess 65 need not be concave, but could take other shapes, such as oval, rectangular or even irregular shapes. The inventors consider that the depression 75 acts to capture or trap the grinding media M so as to promote grinding within the grinding media population, rather than causing grinding in the zone between the grinding media M and grinding discs 12. Another protective element takes the form of an inverted triangular prism or ramp 70 having inclined sides 72, 73, both extending substantially orthogonally from the planar surface 21 of the annular disc body 20. The third protective element takes the form of a sinuous or curved planar element 74 that extends substantially orthogonally from the planar surface 21 of the annular disc body 20. Figure 12G shows yet another embodiment of the protective element that takes the form of an angle or bracket 80 with a single wall 82 connected to a base 85 mounted to the planar surface 21 of the annular disc body.

[0075] While the protective elements illustrated in Figures 12A to 12C and 12E to 12G all extend from the planar surface 21, it will be appreciated that the illustrated protective elements 35, 40, 55, 60, 65, 70, 74, 75, 80 can also extend from the other planar surface 22, either in addition to or as an alternative to the protective elements extending from the planar surface 21. They may also extend radially from the outer edge 23 instead of or in addition to the planar surface 21.

[0076] Furthermore, while the protective elements 25, 40, 55, 74, 80 extend substantially orthogonally from the planar surfaces 21, 22, these protective elements can extend at an angle to the planar surfaces 21, 22 in similar fashion to the embodiment shown in Figures 12A and 12B. Also, the protective elements 25, 40, 55, 60, 70, 74, 80 can be mounted at an angle to the outer edge 23 instead of being tangentially at right angles as illustrated in Figures 9 to 11 and 12A to 12G. The radial posts 50 may also extend at an angle from the outer edge 23 instead of radially outward.

[0077] Yet further configurations for the stirring devices 12 are illustrated in Figures 13A to 13E. These configurations are not encompassed by the wording of the claims but are considered as useful for understanding the invention. In Figure 13A, there are blocks or rectangular prism-shaped flanges 88, 89 that extend from the opposed surfaces of the body 12. The flanges 88, 89 alternate in position so that a flange 89 extending from the lower surface 22 is between flanges 88 extending from the upper surface 21, and vice-versa.

[0078] In Figure 13B, the stirring device 12 comprises a corrugated body with upper corrugations 90 and lower corrugations 92 that form its protective elements. It will be

appreciated that while the corrugations are rectangular, they may be in other forms, such as curved or triangular corrugations.

[0079] In Figure 13C, the stirring device 12 comprises a body formed from radially extending rectangular posts or beams 94, 95 that are offset to one another, so that the beams 94 are above the beams 95. This creates protective elements from the upper beams 94 and the lower beams 95.

[0080] Figure 13D illustrates an embodiment not covered by the subject-matter of the claims, where the protective elements are employed directly to protect the drive shaft 11 while acting as stirring devices. A series of plates 97 project directly from the drive shaft 11 to create protective elements that deflect the slurry particles and grinding media M from the drive shaft. The plates 97 also rotate the feed slurry to promote grinding of the slurry particles by the grinding media M. In this particular embodiment, the plates 97 ensure that grinding occurs in the cavity 15, away from the surfaces of the drive shaft 11, thus minimising wear on the mill body components.

[0081] Figure 13E shows a stirring device 12 that has a saw-tooth configuration with alternating peaks 99 and valleys 100 integrated into its body, so as to form ramp-like deflection surfaces 102 that act as the protective elements.

[0082] It is contemplated in a further aspect that the invention can be implemented in relation to the mill body 2 rather than the mill impeller 10. In this aspect, the invention takes an opposite configuration for the mill body 2 by providing the protective elements 25 on the shelves 14 on the inner sidewalls 13 instead of on the grinding discs 12 so as to deflect the slurry particles and grinding media M from the shelves 14 and inner sidewalls 13. This enables a zone to be created around the shelves 14 and inner sidewalls 13, minimising wear on these components of the mill body 2. In this alternative configuration, as best shown in Figure 14, the blocks 25 are spaced apart around the annular shelf 14 in proximity to the now fully planar annular grinding discs 112 and as the annular shelves 14 are interposed between the grinding discs 12 a zone is created around the outer edges 23 of the grinding discs and part of the opposed planar surfaces 21, 22. Of course, the protective elements in this alternative configuration are not limited to the blocks 25, but can include the many variants described above, especially in relation to Figures 12A to 12G and 13A to 13E. This "static" configuration for the blocks 25 is sufficient to achieve the above stated technical advantages and benefits of the invention. In a further embodiment of this aspect, protective elements 25 can be provided on the inner sidewall 13 between the shelves 14 opposite the grinding discs 12 to further minimise wear. Yet another embodiment has angled annular shelves 14 instead of being orthogonal to the inner sidewall 13 that extend radially inward.

[0083] In yet another embodiment, the protective elements 25 are provided on the drive shaft 11 of the mill impeller to further enhance the zone created around the grinding discs 12. The protective elements 25 in this embodiment are axially aligned with the longitudinal axis 6 of the drive shaft 11 and may be located on annular shelves or discs similar to the mounting ring 28

and/or directly on the drive shaft. Figure 15 shows one variation of this embodiment, using the configuration of Figure 13D, in which the plates 97 are mounted or connected directly to the drive shaft 11. Again, it will be appreciated that the protective elements are not limited to the blocks 25, but can include the many variants described above, especially in relation to Figures 12A to 12G and Figures 13A to 13C and 13E.

[0084] While the embodiments have been described with reference to a vertically arranged mill body, the invention may also be used in other mill types, such as grinding mills having a horizontally arranged or an angled mill body. Furthermore, the invention has also been developed for use with high intensity grinding mills that are grinding fine particulates, but is also equally applicable to other grinding mills of the type that use stationary mill shells with rotating stirring elements.

[0085] It will also be appreciated that the invention is readily applicable to various types of particulate material having a variety of particle sizes and particle size distributions. Particle size is usually measured at the feed and at the discharge outlet. Hence, the particle size of the slurry at the feed inlet is typically measured as F80, meaning that 80% of the feed particles pass through a nominated screen mesh size. For example, a F80 = 100 μ m means that 80% of all particles present will pass through a 100 μ m screen aperture. An alternative measurement is F100, meaning that 100% of the feed particles pass through a nominated screen mesh size. Similarly, it will be understood by one skilled in the art that P80 means that 80% of the particles pass through a nominated screen mesh size. For example, a P80 = 600 μ m means that 80% of all particles present will pass through a 600 μ m screen aperture. The present invention has been primarily developed to process particle sizes in the range of F80 = 30 μ m to F80 = 4000 μ m, especially in the range of F80 = 80 μ m to F80 = 200 μ m for the incoming particulate material and particles sizes in the range of P80 = 0.1 μ m to P80 = 1000 μ m, especially in the range of P80 = 1 μ m to P80 = 50 μ m for the ground product. Hence, the present invention permits the grinding mill 1 to process a wide range of particle sizes for mineral particles having a wider particle size distribution in the above stated F80 and P80 ranges to produce very fine particle sizes down to P80 = 1 μ m. Thus, the invention is readily applicable to many different types of particulate materials and is not limited to particular mineral ore types, but can include iron, quartz, copper, nickel, zinc, lead, gold, silver and platinum. Other particulate materials that can be processed using the invention include concrete, cement, recyclable materials (such as glass, ceramics, electronics and metals), food, paint pigment, abrasives and pharmaceutical substances. In these other applications, the invention is used to reduce the size of the particulate material using a grinding process.

[0086] It will further be appreciated that any of the features in the preferred embodiments of the invention can be combined together and are not necessarily applied in isolation from each other. For example, different types of protective elements can be used on the same mill impeller, such as shown in Figures 12F and 12G. Similarly, the protective elements 25 (or its many variants as described above and in particular with reference to Figures 12A to 12G and 13A to 13E) can be used on both the grinding discs 12 and the shelves 14 together, instead of being exclusive of each other. In addition, some parts of the mill body 2 only have grinding

discs 12 with the protective elements 25 while other parts of the mill body 2 only have shelves 14 with the protective elements 25. This combination is also applicable to the many variants of the protective elements 25 as described above and in particular with reference to Figures 12A to 12G and 13A to 13E. Similar combinations of two or more features from the above described embodiments or preferred forms of the invention can be readily made by one skilled in the art. In embodiments, the protective elements 25 of the grinding discs 12 may act as a skeleton for coating with a dissimilar material that forms a sacrificial protective layer arranged to wear off and expose the protective elements within a very short period of time after the installation and start of the grinding operation. The sacrificial protective material may sometimes be used for manufacturing, shipping and installing purposes.

[0087] By providing protective elements on the stirring devices, shaft assembly or shelves of the mill body to create a zone, the invention reduces the amount of wear and thus prolongs the operational life of the components of the grinding mill, reducing maintenance time, costs and improving efficiency of the grinding mill. The zone generated by the protective elements also promotes slurry particle contact with the grinding media, also improving grinding efficiency. Thus, the grinding mill is able to operate more efficiently, consuming components such as grinding discs as at lower rate while grinding at faster rates. Moreover, the invention when implemented in a mill impeller can be readily retrofitted in existing fine grinding mills. In all these respects, the invention represents a practical and commercially significant improvement over the prior art.

[0088] Although the invention has been described with reference to specific examples, it will be appreciated by those skilled in the art that the invention may be embodied in many other forms.

REFERENCES CITED IN THE DESCRIPTION

Cited references

This list of references cited by the applicant is for the reader's convenience only. It does not form part of the European patent document. Even though great care has been taken in compiling the references, errors or omissions cannot be excluded and the EPO disclaims all liability in this regard.

Patent documents cited in the description

- [US6158680A \[0003\]](#)

- US3307792A [0003]

P A T E N T K R A V

1. Omrøringsanordning (12) til omrøring af et partikelformigt materiale og et formalingsmedie (M) i en formalingsmølle (1), omfattende en flerhed af beskyttelseselementer (25, 35, 40, 50, 55, 60, 70, 74, 80),
5 som strækker sig udad fra et legeme (20) og er adskilt omkring legemet (20) for at afbøje nævnte partikelformige materiale og formalingsmediet (M) fra nævnte legeme (20), hvor legemet (20) omfatter et plant legeme (20) omfattende en ringformet skive med modstående overflader (21, 22) og en ydre kant (23), hvor flerheden af beskyttelseselementer (25, 35, 40, 50, 55, 60, 70, 74, 80) strækker sig radialt
10 fra nævnte ydre kant (23), og hvor flerheden af beskyttelseselementer (25, 35, 40, 50, 55, 60, 70, 74, 80) strækker sig radialt fra hver af de modstående overflader (21, 22).

2. Omrøringsanordning (12) ifølge krav 1, hvor nævnte flerhed af
15 beskyttelseselementer (25, 35, 40, 50, 55, 60, 70, 74, 80) strækker sig i en vinkel til en overflade af nævnte legeme (20).

3. Omrøringsanordning (12) ifølge krav 2, hvor nævnte vinkel er i området fra 10° til 170° , fortrinsvis 20° til 160° , fortrinsvis 30° til 150° , fortrinsvis 40° til 130° , fortrinsvis 50° til 120° , fortrinsvis 60° til 110° ,
20 mere fortrinsvis 70° til 100° , endnu mere fortrinsvis 80° til 95° og mest fortrinsvis 85° til 90° .

4. Omrøringsanordning (12) ifølge et hvilket som helst af de foregående krav, hvor nævnte flerhed af beskyttelseselementer (25, 35, 40, 50, 55, 60, 70, 74, 80) omfatter mindst et eller flere af et fremspring,
25 et aflangt legeme, et blokformet element, en flange, en tand, et plant element, en ledeskovl, et blad, en ribbe, en plade, en stang, en stolpe, en søjle, et kanalformet element, et V-formet element, et U-formet element, et rampelignende element og et kileformet element.

5. Omrøringsanordning (12) ifølge krav 4, hvor nævnte flerhed af
30 beskyttelseselementer (25) omfatter nævnte blokformede element (25), hvor nævnte blokformede element (25) er forbundet med nævnte

plane legeme (20), så at modstående sider (31, 32) af nævnte blokformede element (25) strækker sig udad fra nævnte modstående overflader (21, 22) af nævnte plane legeme (20), og/eller hvor nævnte blokformede element (25) omfatter en ydre ende (33), som strækker sig radialt udad fra en ydre kant (23) af nævnte plane legeme (20).

6. Anvendelse af omrøringsanordningen (12) ifølge et hvilket som helst af de foregående krav i et omrøringsanordningsarrangement (10).

7. Omrøringsanordningsarrangement (10) til et formalingsmøllelegeme (2), omfattende en flerhed af omrøringsanordninger (12) ifølge et hvilket som helst af kravene 1 til 5 monteret på en drivaksel (11) for at rotere nævnte omrøringsanordninger (12).

8. Anvendelse af omrøringsanordningsarrangementet (10) ifølge krav 7 som et møllehjul i en formalingsmølle (1).

9. Møllelegeme (2) omfattende omrøringsanordningsarrangementet (10) ifølge krav 7.

10. Formalingsmølle (1) omfattende nævnte møllelegeme (2) ifølge krav 9.

11. Møllelegeme (2) omfattende et indløb (7) til modtagelse af et partikelformigt materiale, et udløb (8) til udledning af formalede partikler og en hylde (14), som strækker sig fra en indre sidevæg (13), hvilken hylde (14) omfatter en flerhed af beskyttelseselementer (25, 35, 40, 50, 55, 60, 70, 74, 80), som strækker sig udad fra nævnte hylde (14) og er adskilt omkring nævnte hylde (14) til at afbøje det partikelformige materiale og nævnte formalede medie (M) fra nævnte hylde (14), hvor nævnte flerhed af beskyttelseselementer (25, 35, 40, 50, 55, 60, 70, 74, 80) strækker sig radialt fra nævnte hylde (14), og hvor nævnte hylde (14) omfatter modstående overflader, og nævnte flerhed af beskyttelseselementer (25, 35, 40, 50, 55, 60, 70, 74, 80) strækker sig fra hver af nævnte modstående overflader.

12. Møllelegeme (2) ifølge krav 11, hvor nævnte flerhed af beskyttelseselementer (25, 35, 40, 50, 55, 60, 70, 74, 80) strækker sig i en

vinkel til mindst én af de modstående overflader.

13. Formalingsmølle (1) omfattende et møllelegeme (2) ifølge et hvilket som helst af kravene 11 til 12 og et omrøringsanordningsarrangement (10), hvilket omrøringsanordningsarrangement (10) har en
5 flerhed af omrøringsanordninger (12) monteret til en drivaksel (11) for at rotere nævnte omrøringsanordninger (12).

14. Formalingsmølle (1) ifølge et hvilket som helst af kravene 10 til 13, hvor nævnte formalingsmølle (1) er til formaling af et partikelformigt materiale, som omfatter mineralske malmpartikler.

10 15. Formalingsmølle (1) ifølge krav 14, hvor nævnte mineralske malmpartikler omfatter mindst én af jern, kvarts, kobber, nikkel, zink, bly, guld, sølv, platin, wolfram, krom, silicium og kombinationer deraf.

16. Formalingsmølle (1) ifølge et hvilket som helst af kravene 10 og 13 til 15, hvor nævnte formalingsmølle (1) er en finformalingsmølle,
15 som har et strømforbrug på 10 til 70 kWhr/t, fortrinsvis på 30 kWhr/t.

17. Fremgangsmåde til formaling af et partikelformigt materiale i en formalingsmølle af typen med et møllelegeme og en drivaksel til at rotere en flerhed af omrøringsanordninger i nævnte møllelegeme, hvilken fremgangsmåde omfatter:

20 at tilvejebringe en formalingsmølle (1) ifølge krav 10;

at indføre et formalingsmedie (M) i nævnte møllelegeme (2);

at indføre nævnte partikelformige materiale gennem et indløb (7);

og

25 at drive nævnte drivaksel (11) til at rotere nævnte omrøringsanordninger (12) i nævnte møllelegeme (2);

hvor nævnte rotation af nævnte omrøringsanordninger (12) inducerer en rotationsstrøm af nævnte partikelformige materiale inden i nævnte møllelegeme (2) for at formale det partikelformige materiale mod formalingsmediet (M) for at fremstille mineralske partikler af mindre størrelse; og
30

hvor nævnte ene eller flere beskyttelselementer (25, 35, 40, 50,

55, 60, 70, 74, 80) afbøjer nævnte partikelformige materiale og nævnte formalingsmedie (M) væk fra nævnte omrøringsanordninger (12).

18. Fremgangsmåde ifølge krav 17, yderligere omfattende at danne en zone omkring nævnte omrøringsanordninger (12), hvor nævnte formalingsmedie (M) holdes og bevæges væk fra omrøringsanordningen (12).

19. Fremgangsmåde til formaling af et partikelformigt materiale i en formalingsmølle af typen med et møllelegeme og en drivaksel til rotering af en flerhed af omrøringsanordninger inden i nævnte møllelegeme, hvilken fremgangsmåde omfatter:

- at tilvejebringe en formalingsmølle (1) ifølge krav 13;
- at indføre formalingsmedie (M) i møllelegemet (2);
- at indføre det partikelformige materiale gennem et indløb (7); og
- at drive nævnte drivaksel (11) til at rotere nævnte omrøringsanordninger (12) inden i nævnte møllelegeme (2);

hvor nævnte rotation af nævnte omrøringsanordninger (12) inducerer en roterende strøm af nævnte partikelformige materiale inden i nævnte møllelegeme (2) for at formale nævnte partikelformige materiale mod formalingsmediet (M) for at fremstille mineralske partikler af mindre størrelse; og

hvor nævnte ene eller flere beskyttelseselementer (25, 35, 40, 50, 55, 60, 70, 74, 80) afbøjer nævnte partikelformige materiale og nævnte formalingsmedie (M) fra hylderne (14) og de indre sidevægge (13) af møllelegemet (2) af nævnte formalingsmølle (1).

DRAWINGS

Drawing

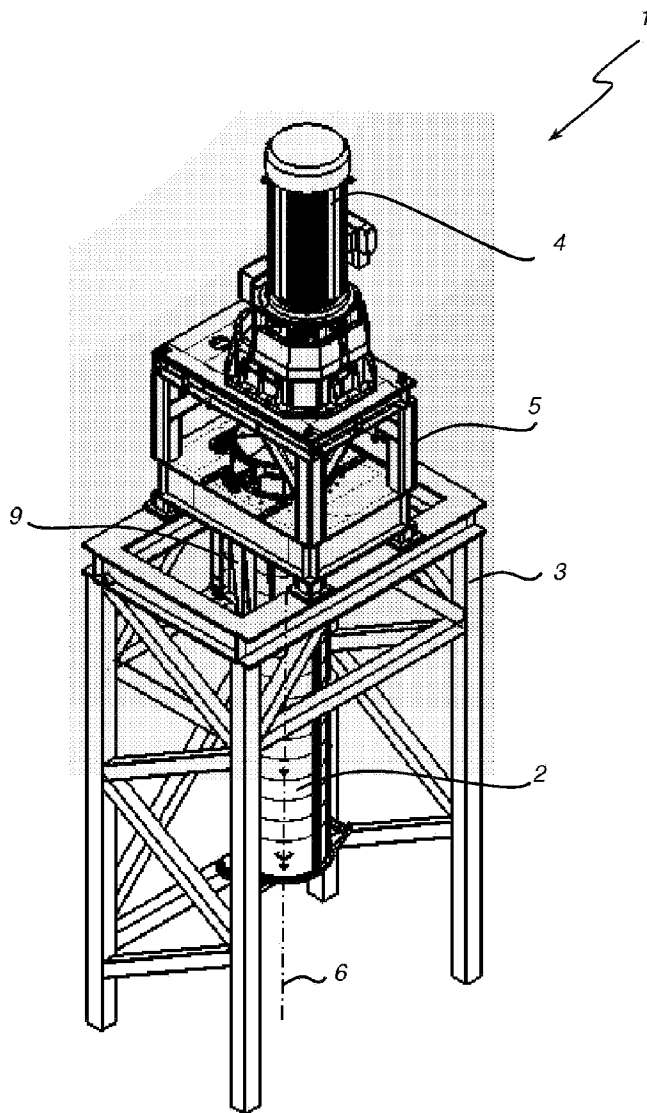

Fig. 1

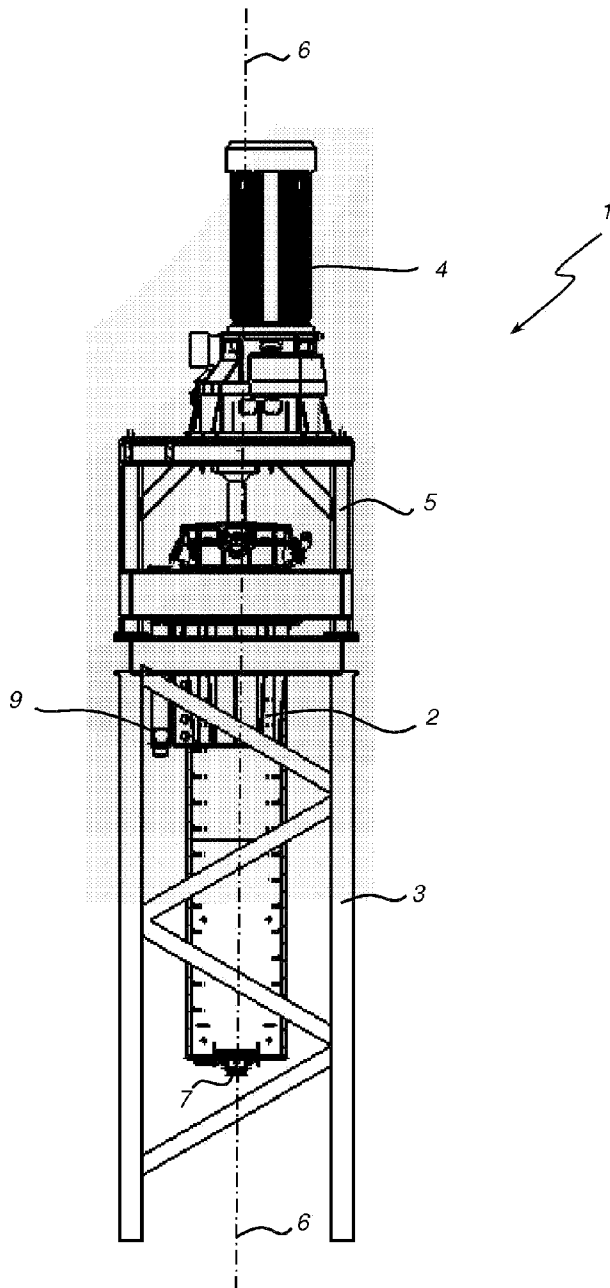

Fig. 2

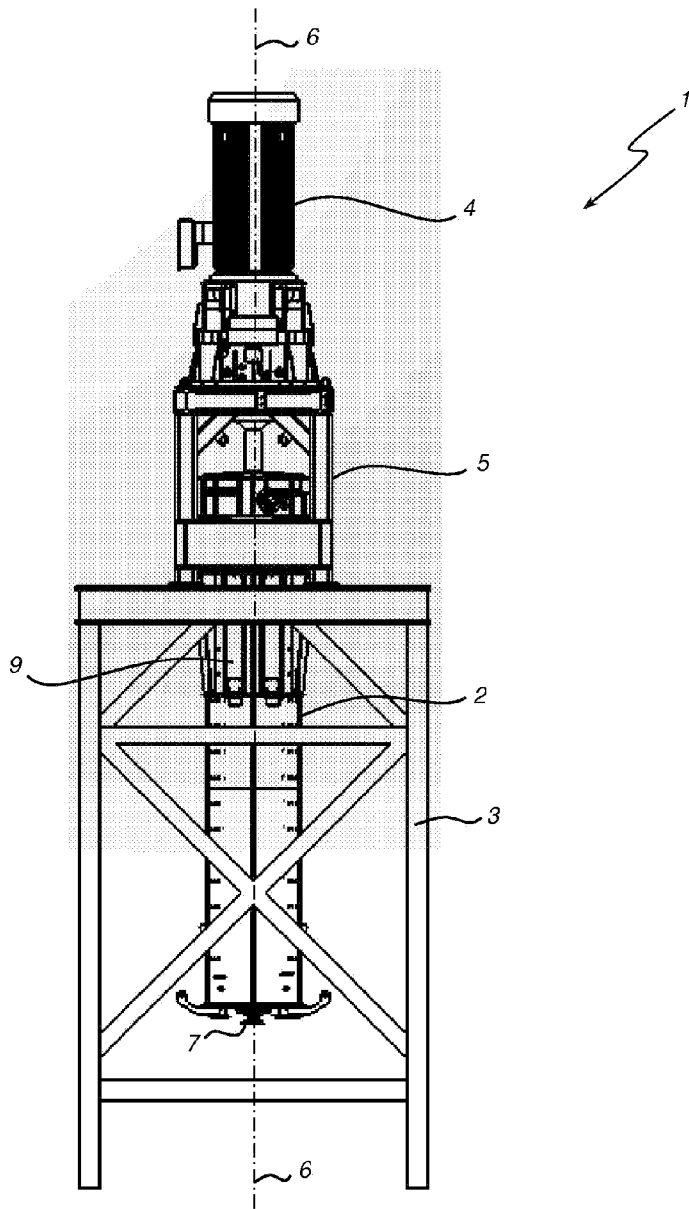

Fig. 3

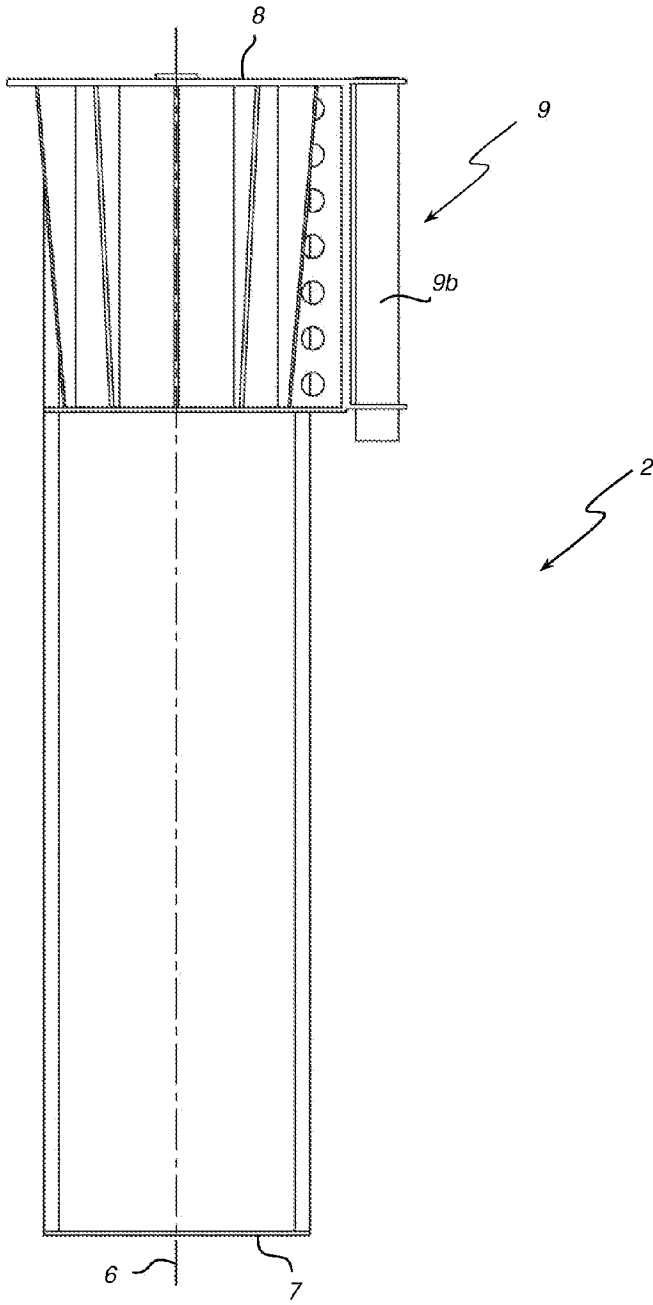

Fig. 4

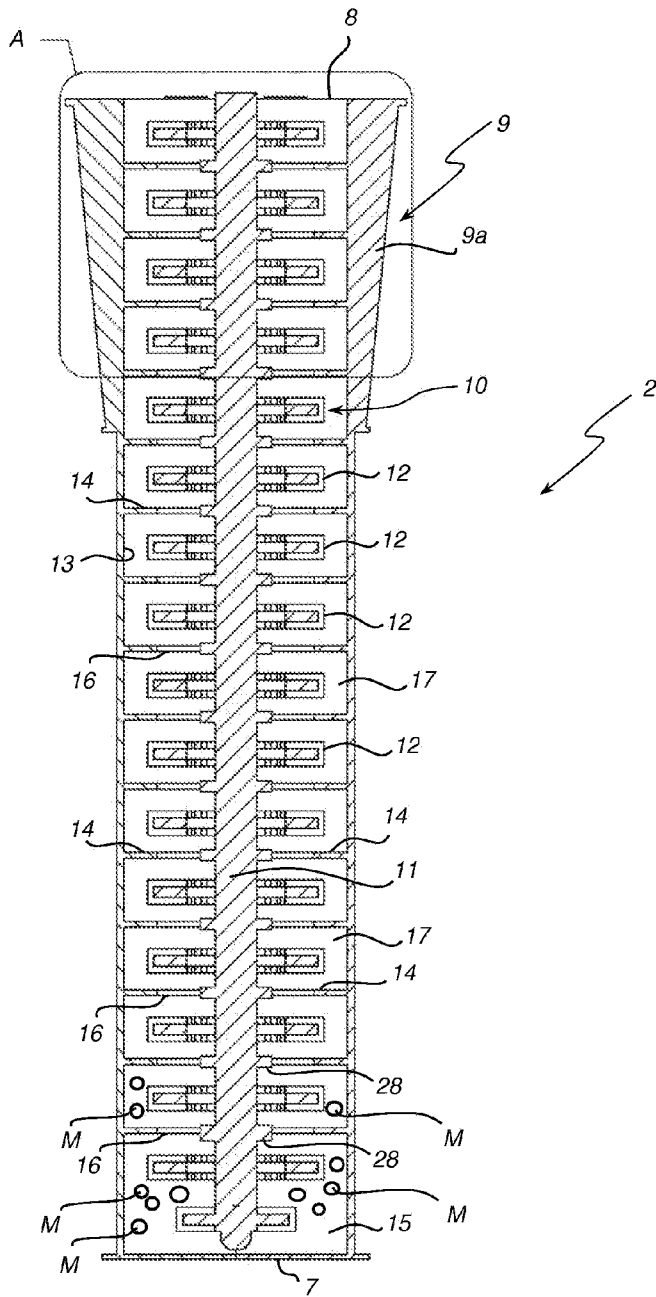

Fig. 5

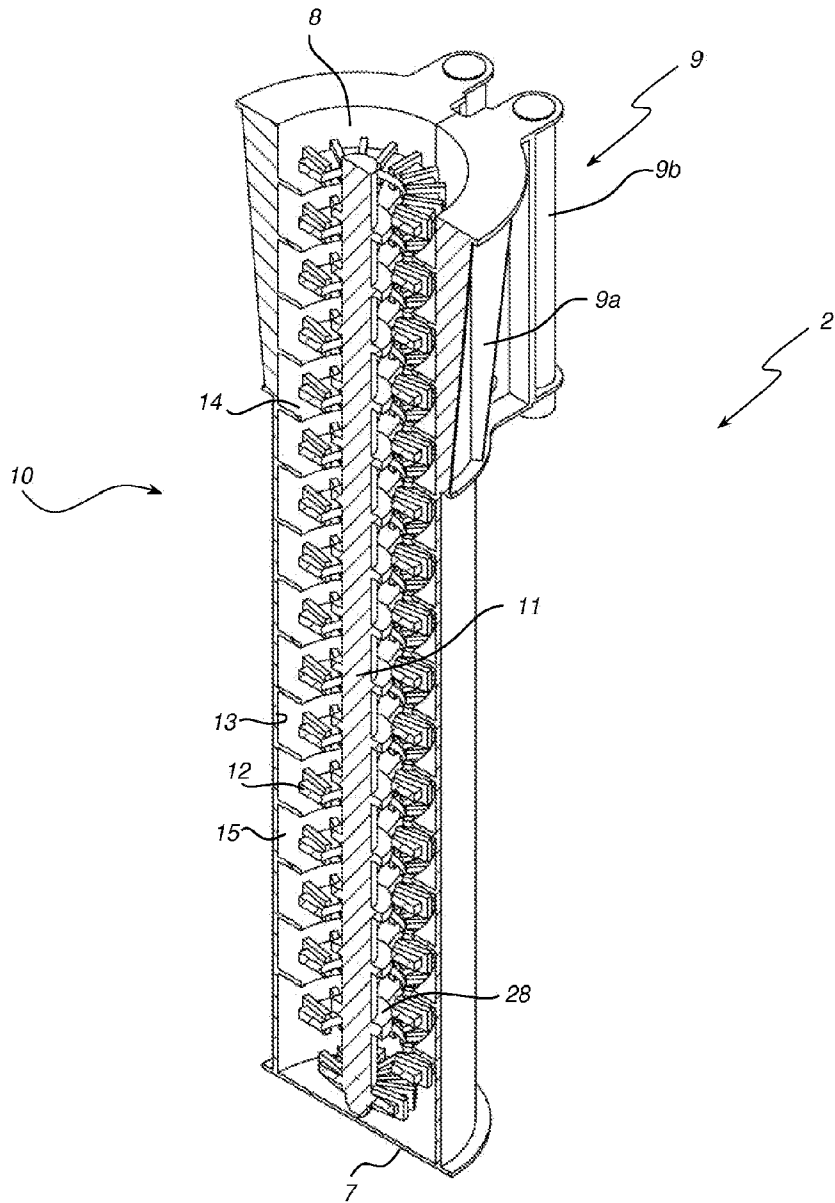

Fig. 6

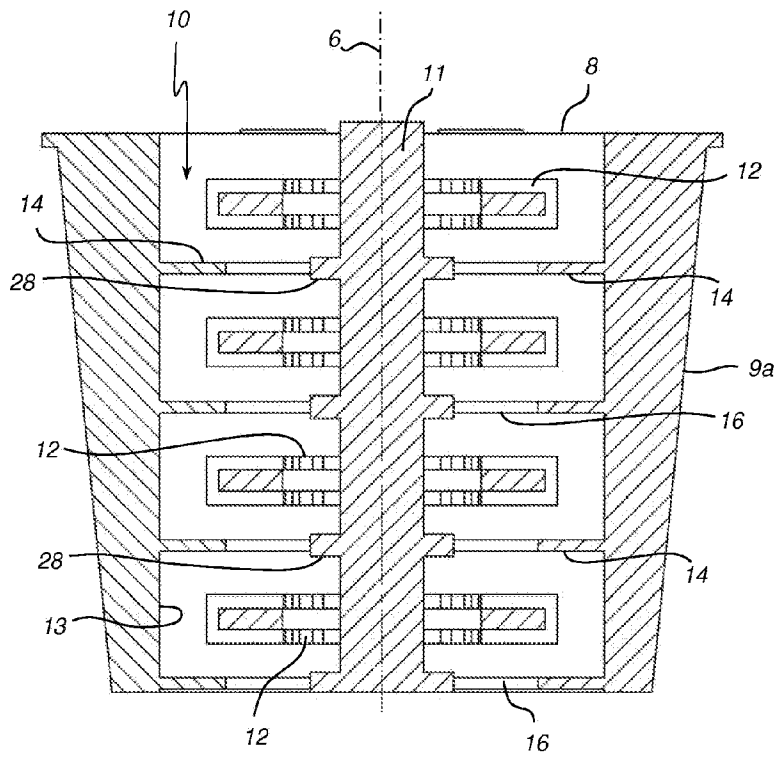

Fig. 7

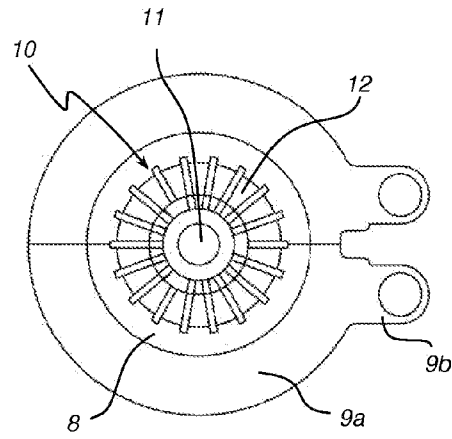

Fig. 8

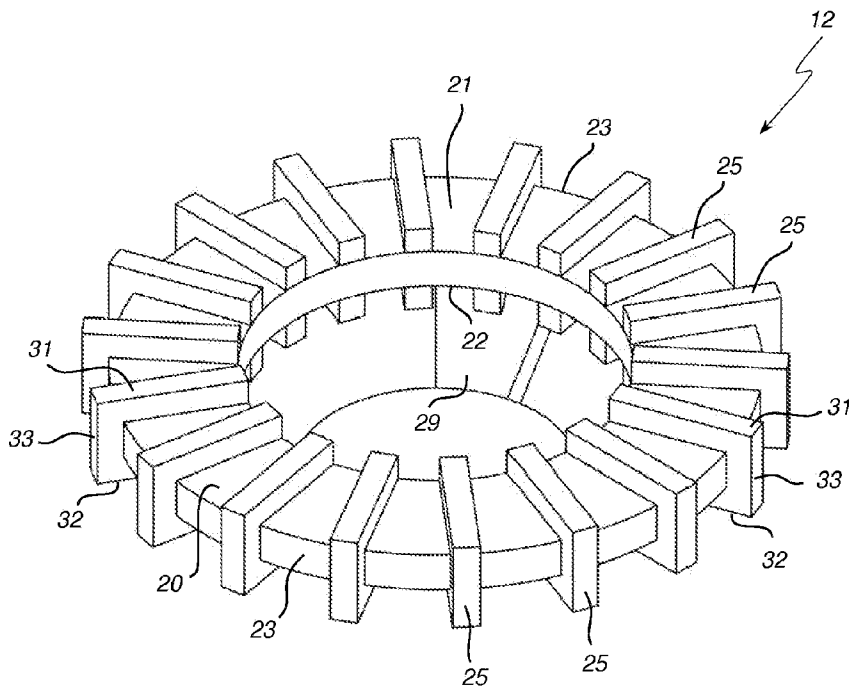

Fig. 9

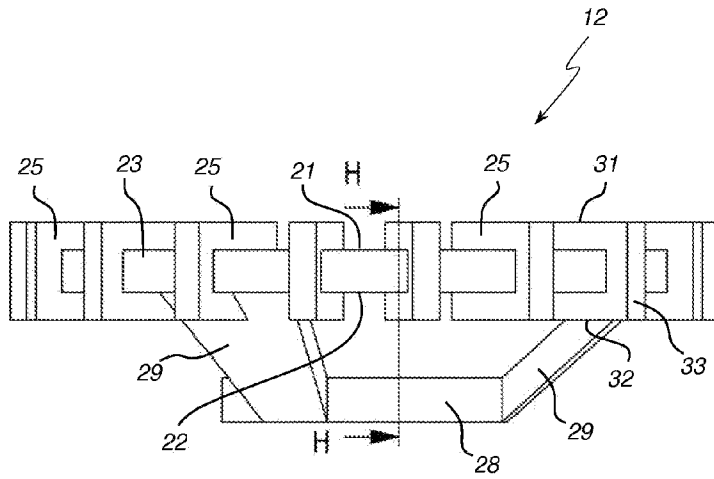

Fig. 10

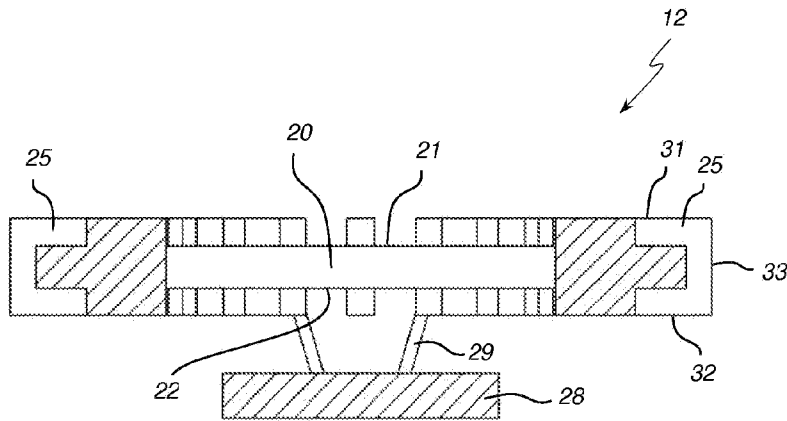

Fig. 11

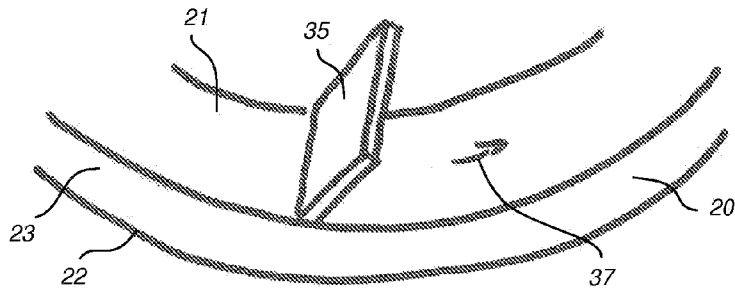

Fig. 12A

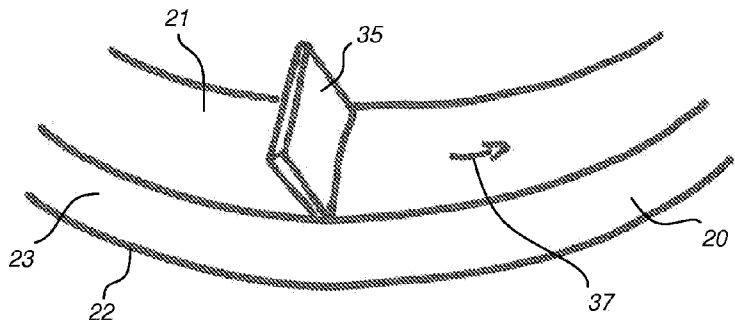

Fig. 12B

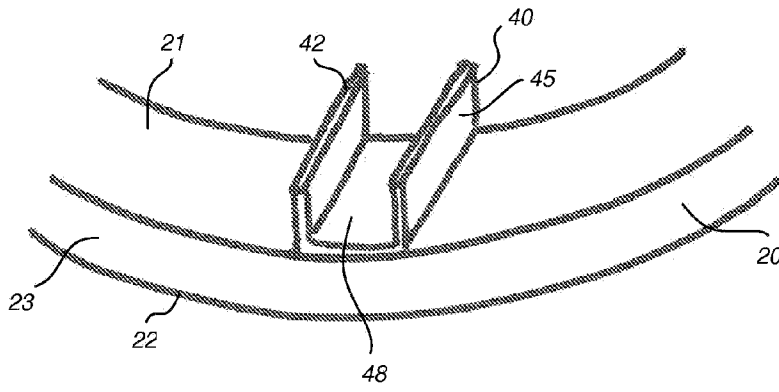

Fig. 12C

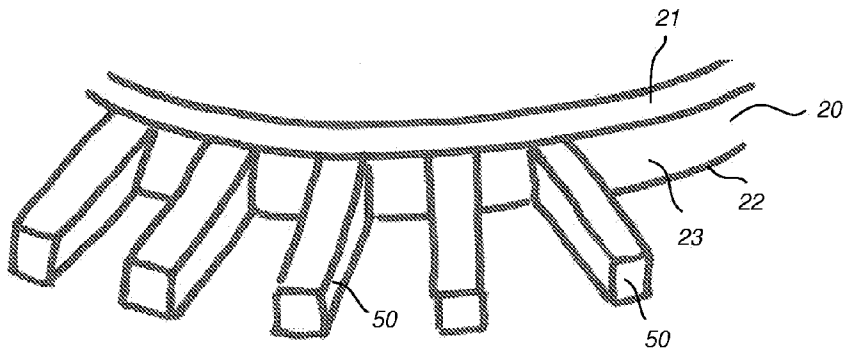

Fig. 12D

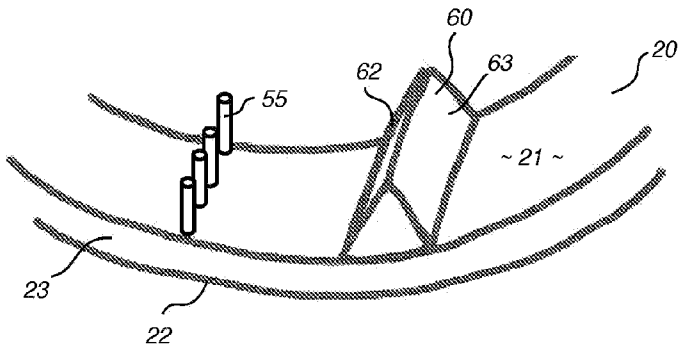

Fig. 12E

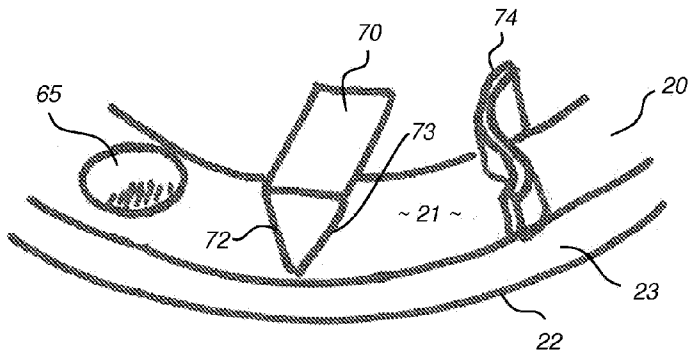

Fig. 12F

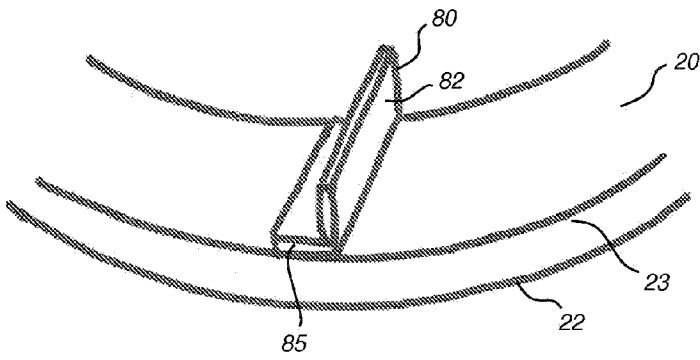

Fig. 12G

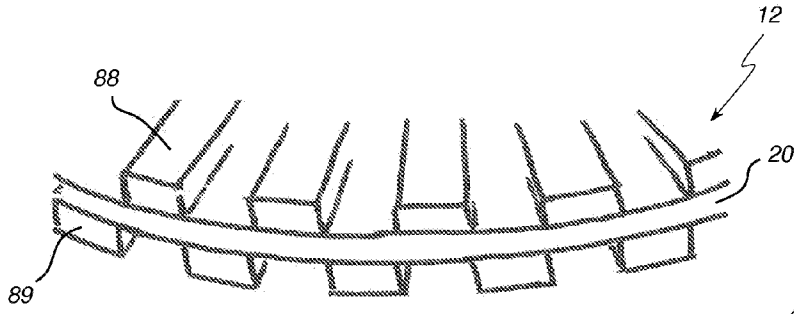

Fig. 13A

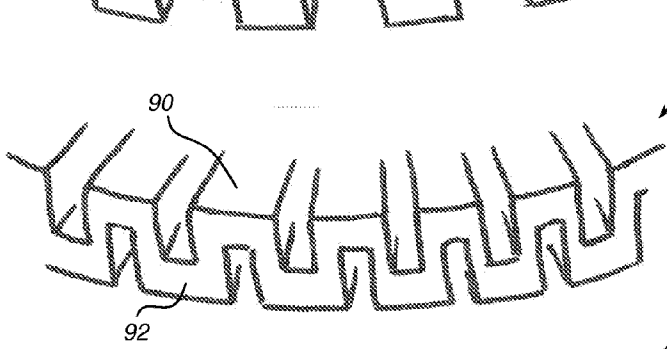

Fig. 13B

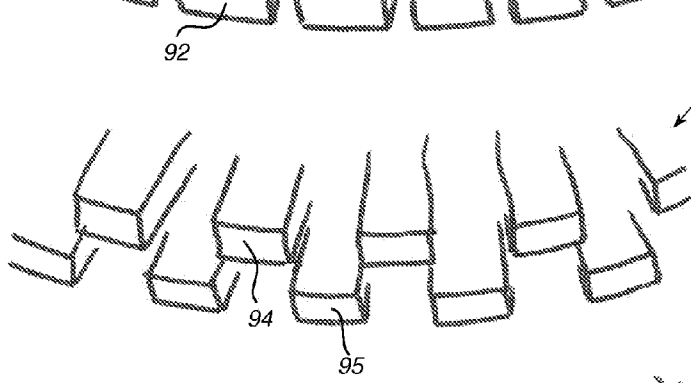

Fig. 13C

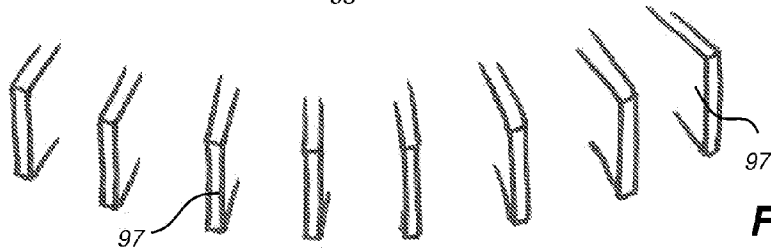

Fig. 13D

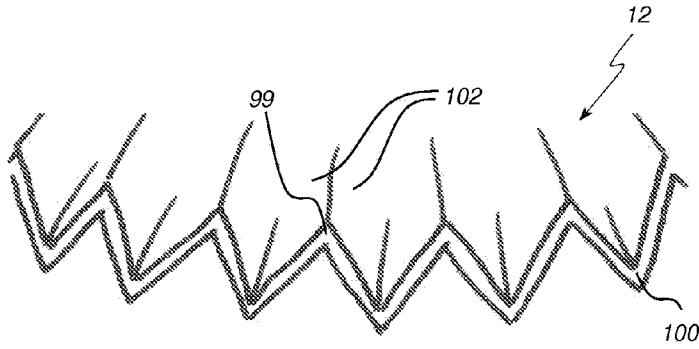

Fig. 13E

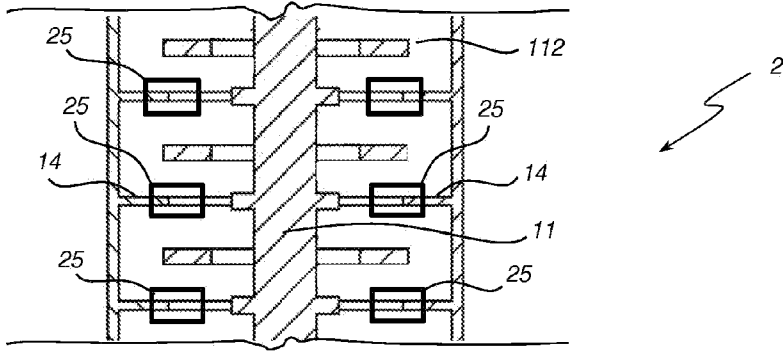

Fig. 14

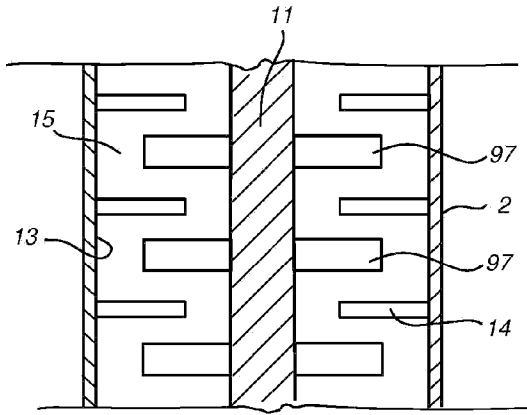

Fig. 15