



- (51) **International Patent Classification:**
A61F 2/24 (2006.01)
- (21) **International Application Number:**
PCT/US2014/045961
- (22) **International Filing Date:**
9 July 2014 (09.07.2014)
- (25) **Filing Language:** English
- (26) **Publication Language:** English
- (30) **Priority Data:**
61/847,515 17 July 2013 (17.07.2013) US
14/170,388 31 January 2014 (31.01.2014) US
14/170,407 31 January 2014 (31.01.2014) US
- (71) **Applicant: CEPHEA VALVE TECHNOLOGIES, INC.** [US/US]; 3050 Three Springs Court, San Jose, CA 95140 (US).
- (72) **Inventors: ERZBERGER, Gary;** 3050 Three Springs Court, San Jose, CA 95140 (US). **CORCORAN, Michael, P.;** 3050 Three Springs Court, San Jose, CA 95140 (US). **GRANADA, Juan, F.;** 3050 Three Springs Court, San Jose, CA 95140 (US). **WALLACE, Dan;** 3050 Three Springs Court, San Jose, CA 95140 (US). **MONTORFANO, Matteo;** 3050 Three Springs Court, San Jose, CA 95140 (US). **CHIEFFO, Alaide;** 3050 Three Springs Court, San Jose, CA 95140 (US). **THAURE, Thierry;** 3050 Three Springs Court, San Jose, CA 95140 (US). **LA-DUCA, Robert;** 3050 Three Springs Court, San Jose, CA 95140 (US).
- (74) **Agents: SHAY, James R.** et al.; Shay Glenn LLP, 2755 Campus Drive, Suite 210, San Mateo, CA 94403 (US).
- (81) **Designated States** (*unless otherwise indicated, for every kind of national protection available*): AE, AG, AL, AM, AO, AT, AU, AZ, BA, BB, BG, BH, BN, BR, BW, BY, BZ, CA, CH, CL, CN, CO, CR, CU, CZ, DE, DK, DM, DO, DZ, EC, EE, EG, ES, FI, GB, GD, GE, GH, GM, GT, HN, HR, HU, ID, IL, IN, IR, IS, JP, KE, KG, KN, KP, KR, KZ, LA, LC, LK, LR, LS, LT, LU, LY, MA, MD, ME, MG, MK, MN, MW, MX, MY, MZ, NA, NG, NI, NO, NZ, OM, PA, PE, PG, PH, PL, PT, QA, RO, RS, RU, RW, SA, SC, SD, SE, SG, SK, SL, SM, ST, SV, SY, TH, TJ, TM, TN, TR, TT, TZ, UA, UG, US, UZ, VC, VN, ZA, ZM, ZW.
- (84) **Designated States** (*unless otherwise indicated, for every kind of regional protection available*): ARIPO (BW, GH, GM, KE, LR, LS, MW, MZ, NA, RW, SD, SL, SZ, TZ, UG, ZM, ZW), Eurasian (AM, AZ, BY, KG, KZ, RU, TJ, TM), European (AL, AT, BE, BG, CH, CY, CZ, DE, DK, EE, ES, FI, FR, GB, GR, HR, HU, IE, IS, IT, LT, LU, LV, MC, MK, MT, NL, NO, PL, PT, RO, RS, SE, SI, SK, SM, TR), OAPI (BF, BJ, CF, CG, CI, CM, GA, GN, GQ, GW, KM, ML, MR, NE, SN, TD, TG).
- Published:**
— *without international search report and to be republished upon receipt of that report (Rule 48.2(g))*



WO 2015/009503 A2

(54) **Title:** SYSTEM AND METHOD FOR CARDIAC VALVE REPAIR AND REPLACEMENT

(57) **Abstract:** A prosthetic mitral valve includes a proximal anchor, a distal anchor, and a central portion therebetween. The proximal and distal anchors each include a first outer frame and a second outer frame. The first outer frame includes a plurality of first arcs joined together, and the second outer frame includes a plurality of second arcs joined together. The plurality of first arcs are out of phase relative to the plurality of second arcs.

SYSTEM AND METHOD FOR CARDIAC VALVE REPAIR AND REPLACEMENT**INCORPORATION BY REFERENCE**

5 [0001] All publications and patent applications mentioned in this specification are herein incorporated by reference to the same extent as if each individual publication or patent application was specifically and individually indicated to be incorporated by reference.

FIELD OF INVENTION

10 [0002] The present invention relates generally to the treatment of cardiac valve disorders, such as mitral valve replacement, using minimally invasive techniques.

BACKGROUND

[0003] The mitral valve lies between the left atrium and the left ventricle of the heart. Various diseases can affect the function of the mitral valve, including degenerative mitral valve disease and mitral valve prolapse. These diseases can cause mitral stenosis, in which the valve fails to open fully and thereby obstructs blood flow, and/or mitral insufficiency, in which the mitral valve is incompetent and blood flows passively in the wrong direction.

[0004] Many patients with heart disease, such as problems with the mitral valve, are intolerant of the trauma associated with open-heart surgery. Age or advanced illness may have impaired the patient's ability to recover from the injury of an open-heart procedure. Additionally, the high costs are associated with open-heart surgery and extra-corporeal perfusion can make such procedures prohibitive.

[0005] Patients in need of cardiac valve repair or cardiac valve replacement can be served by minimally invasive surgical techniques. In many minimally invasive procedures, small devices are manipulated within the patient's body under visualization from a live imaging source like ultrasound, fluoroscopy, or endoscopy. Minimally invasive cardiac procedures are inherently less traumatic than open procedures and may be performed without extra-corporeal perfusion, which carries a significant risk of procedural complications.

30 [0006] Minimally invasive aortic valve replacement devices, such as the Medtronic Corevalve or the Edwards Sapien, deliver aortic valve prostheses through small tubes which may be positioned within the heart through the aorta via the femoral artery or through the apex of the heart. However, current cardiac valve prostheses are not designed to function

effectively within the mitral valve. Further, current cardiac valve prostheses delivered via a minimally invasive device are often difficult to place correctly within the native valve, difficult to match in size to the native valve, and difficult to retrieve and replace if initially placed incorrectly.

5 [0007] Accordingly, it is desirable to have a mitral valve replacement that solves some or all of these problems.

SUMMARY OF THE DISCLOSURE

10 [0008] In general, in one embodiment, a prosthetic mitral valve includes a proximal anchor, a distal anchor, and a central portion therebetween. The proximal and distal anchors each include a first outer frame and a second outer frame. The first outer frame includes a plurality of first arcs joined together, and the second outer frame includes a plurality of second arcs joined together. The plurality of first arcs are out of phase relative to the plurality of second arcs.

15 [0009] This and other embodiments can include one or more of the following features. The first plurality of arcs can be movable relative to the second plurality of arcs. The first and second outer frames can be substantially circular. The plurality of first arcs can be disposed around substantially the entire first outer frame, and the plurality of second arcs can be disposed around substantially the entire second outer frame. The plurality of first arcs can lie 20 substantially in a first plane, and the plurality of second arcs can lie substantially in an adjacent second plane. The first and second arcs can be approximately 90 degrees out of phase. The first and second outer frames can be made of wire rope. The wire rope of the first outer frame can have an opposite lay than a lay of the wire rope of the second outer frame. The proximal anchor and distal anchor can be substantially parallel to one another. The 25 central portion can include substructures connecting the proximal and distal anchors. The substructures can be hexagonal. The proximal anchor, distal anchor, and central portion can be configured to expand from a constrained configuration to an expanded configuration. The device can be configured to foreshorten upon expansion of the proximal anchor, distal anchor, and central portion from the constrained configuration to the expanded configuration. 30 The proximal anchor and the distal anchor can each have a diameter in the expanded configuration that is greater than a diameter of the central portion in the expanded configuration.

[0010] In general, in one embodiment, a prosthetic mitral valve includes a valve frame comprising a proximal anchor, a distal anchor, and a central portion therebetween. The valve

frame is configured to expand from a constrained configuration to an expanded configuration. A plurality of struts is attached to the central portion and extends distally past the distal anchor. A plurality of leaflets are secured to the plurality of struts such that at least a portion of each leaflet extends distally past the distal anchor.

5 [0011] This and other embodiments can include one or more of the following features. The valve frame can be configured to self-expand. The plurality of leaflets can be attached to the central portion. The plurality of leaflets can include a biomaterial or a polymer. The proximal anchor can be covered with a skirt configured to seal the prosthetic valve. The skirt can include a biomaterial or polymer. The outer perimeter of the proximal anchor can be
10 substantially circular when covered with the skirt. The plurality of leaflets can be arranged to fill an inner diameter of the mitral valve prosthetic. The ratio of the inner diameter to a height of the plurality of struts can be approximately 2:1. The valve frame can be configured to foreshorten upon expansion of the valve frame from the constrained configuration to the expanded configuration. The proximal anchor and the distal anchor can each have a diameter
15 in the expanded configuration that can be greater than a diameter of the central portion in the expanded configuration.

[0012] In general, in one embodiment, a prosthetic mitral valve includes a valve frame having a proximal anchor, a distal anchor, and a central portion therebetween. The valve frame is configured to expand from a constrained configuration to an expanded
20 configuration. The ratio of an outer diameter of the central portion to a length of the valve frame in the expanded configuration is at least 1.1.

[0013] This and other embodiments can include one or more of the following features. The valve frame can be configured to self-expand. The ratio can be less than or equal to 2. The ratio of the outer diameter of the proximal anchor or the distal anchor to the length of the
25 device can be greater than or equal to 2. The outer diameter of the central portion can be between 25 and 40mm. The length can be less than or equal to 22mm. The proximal and distal anchors can extend radially outward from the central portion. The outer diameter of the proximal and distal anchors can be at least 38mm.

[0014] In general, in one embodiment a method of delivering a prosthetic mitral valve
30 includes delivering a distal anchor from a delivery sheath such that the distal anchor self-expands inside a first heart chamber on a first side of the mitral valve annulus, pulling proximally on the distal anchor such that the distal anchor self-aligns within the mitral valve annulus and the distal anchor rests against tissue of the ventricular heart chamber, and delivering a proximal anchor from the delivery sheath to a second heart chamber on a second

side of the mitral valve annulus such that the proximal anchor self-expands and moves towards the distal anchor to rest against tissue of the second heart chamber. The self-expansion of the proximal anchor captures tissue of the mitral valve annulus therebetween.

[0015] This and other embodiments can include one or more of the following features.

5 The first heart chamber can be a ventricular heart chamber, and the second heart chamber can be an atrial heart chamber.

[0016] In general, in one embodiment, a method of delivering a prosthetic mitral valve includes securing a prosthetic valve within a delivery device by extending a plurality of wires of the delivery device through a proximal anchor so as to collapse the proximal anchor, extending the prosthetic delivery device into a heart with the prosthetic valve covered by a sheath of the delivery device, pulling the sheath proximally to expose a distal anchor of the prosthetic valve, thereby allowing the distal anchor to self-expand into place on a first side of the mitral valve annulus, pulling the sheath proximally to expose the proximal anchor, loosening the wires of the delivery device so as to allow the proximal anchor to self-expand into place on a second side of the mitral valve annulus, and removing the delivery device from the heart.

[0017] This and other embodiments can include one or more of the following features.

The method can further include tightening the wires after loosening the wires so as to collapse the proximal anchor again, repositioning the proximal anchor to a second location on the second side of the mitral valve annulus and loosening the wires of the delivery device so as to allow the proximal anchor to self-expand into place at the second location on the second side of the mitral valve annulus. Extending a plurality of wires of the delivery device through a proximal anchor so as to collapse the proximal anchor and can include extending a plurality of wires through arcs of the proximal anchor. Neighboring retention wires can extend through neighboring arcs. The method can further include extending a guidewire down a central lumen of the delivery device before extending the prosthetic delivery device into the heart. Tightening and loosening the wires of the delivery device can be performed with a control on a handle of the delivery device.

[0018] In general, in one embodiment, a delivery device includes a central longitudinal structure having a plurality of tubes extending therethrough, a retention wire extending within each tube, a sheath, a handle, and a control on the handle. Each tube has a tubular wall and an aperture in the tubular wall. Each retention wire configured to extend through a portion of a medical device at the aperture. The sheath is configured to fit over and slide relative to the central longitudinal structure and the medical device. The handle is connected

to the central longitudinal structure. The control on the handle is configured to tighten the wires to collapse at least a portion of the medical device and to loosen the wires to expand the portion of the medical device.

[0019] This and other embodiments can include one or more of the following features.

5 The delivery device can further include a central lumen extending through the central longitudinal structure. The central lumen can be configured to house a guidewire. The retention wires can be made of nitinol or liquid crystal polymer fiber. There can be between 4 and 20 retention wires and tubes. The delivery device can further include a tapered distal tip connected to the central longitudinal structure. The control can be further configured to
10 retighten the wires after loosening to collapse the portion of the medical device again.

BRIEF DESCRIPTION OF THE DRAWINGS

[0020] The novel features of the invention are set forth with particularity in the claims. A better understanding of the features and advantages of the present invention will be
15 obtained by reference to the following detailed description that sets forth illustrative embodiments, in which the principles of the invention are utilized, and the accompanying drawings of which:

[0021] Figures 1A-1E are various view of a compliant, self-centering valve prosthesis structure suitable for delivery via minimally invasive surgical techniques. Figures 1A and
20 1B are isometric views of the prosthesis. Figure 1C is a proximal view of a proximal anchor of the prosthesis. Figure 1D is a proximal view of the prosthesis. Figure 1E is a side view of the prosthesis.

[0022] Figures 2A-2C show an exemplary prosthesis with leaflets attached thereto. Figure 2A is an isometric view of the prosthesis. Figure 2B is a distal view of the prosthesis.
25 Figure 2C is a section view of the prosthesis.

[0023] Figures 3A-3B show the prosthesis of Figures 1A-1E with various dimensions marked thereon. Figure 3A is a proximal view of the prosthesis. Figure 3B is a side view of the prosthesis.

[0024] Figure 4A shows a delivery device with a prosthesis fully loaded therein. Figure
30 4B shows the delivery device with the prosthesis deployed.

[0025] Figures 5A-5D shows exemplary steps for delivery a valve prosthesis. Figure 5A shows a delivery device housing the prosthesis. Figure 5B shows the distal anchor of the prosthesis deployed with the proximal anchor folded up therearound. Figure 5C shows the

sheath of the delivery device pulled back to expose the retention wires of the delivery device.

Figure 5D shows the valve prosthesis fully deployed around the delivery device.

[0026] Figures 6A-6D show placement of a prosthesis within the mitral valve using a delivery device.

5 [0027] Figure 7 shows a valve prosthesis structure with integral folding hooks for gripping cardiac tissue.

[0028] Figures 8A-8B and 9A-9B show various wire rope configurations.

[0029] Figures 10A-10B show a mechanism for releasing the retention wires of a delivery device by pulling proximally on the retention wires.

10 [0030] Figures 11A-11B show a mechanism for loosening the retention wires of a delivery device by pushing distally on the retention wires.

[0031] Figures 12A-12B show an exemplary mechanism for looping the proximal anchor with the retention wires of a delivery device. Figure 12A shows the use of twelve retention wires. Figure 12B shows the use of six retention wires.

15 [0032] Figure 13 shows an alternative mechanism for looping the proximal anchor over a delivery device.

DETAILED DESCRIPTION

[0033] Described herein is a flexible, self-orienting cardiac valve prosthesis configured to be delivered through minimally invasive techniques. The prosthesis can include a proximal anchor (e.g., configured to be placed in the ventricle), a distal anchor (e.g., configured to be placed in the atrium), a central portion or column between the anchors, a plurality of struts extending distally (e.g., into the ventricle), and a plurality of leaflets attached to the struts. The prosthesis can be self-expanding, such as be made of super elastic nickel titanium (nitinol). In some embodiments, the prosthesis can be made of woven
25 stranded nitinol.

[0034] The prosthesis described herein can be delivered to a cardiac valve orifice, such as the mitral valve, by using minimally invasive techniques to access cardiac valves through small incisions in the patient's body, passing the prosthesis through the apex of the heart,
30 through the aorta via femoral artery access, through the aorta via an intercostal puncture, through the vena cava via femoral vein access, through the vena cava via jugular access, and through the venous system into the left heart via a transseptal puncture. The flexible prosthesis can be folded and compressed to fit within a delivery tube. The delivery tube can

used to position the prosthesis at the treatment site, and if necessary, re-sheath, reposition, and re-deploy the device.

[0035] During deployment, the distal anchor can be deployed first in a cardiac chamber, such as the ventricle, and retracted to a seated position against the valve orifice, such as the mitral valve orifice. Then the center column and proximal anchor may then be deployed in another cardiac chamber, such as the atrium, sandwiching the valve orifice securely between the anchors in opposing cardiac chambers.

[0036] Embodiments of the invention are designed to secure the valve prosthesis in the orifice by applying a radial force from the center column structure of the prosthesis outward against the cardiac orifice and by sandwiching the cardiac orifice between distal and proximal anchors that are larger in diameter than the orifice. Further engagement between the prosthesis and tissue may be added by securing small, curved wire hooks into the sub-structures of the valve prosthesis.

[0037] Figures 1A-1E show an exemplary embodiment of a valve prosthesis 100. The valve prosthesis includes a proximal anchor 2, a distal anchor 3, and a central portion 4 therebetween. A central opening 15 extends through the center of the prosthesis 100. The central portion 4 can substantially trace the perimeter of the central opening 15 while each anchor 2, 3 can extend outwardly therefrom in an annular shape. The proximal anchor 2, distal anchor 3, and central portion 4 can be formed of wire, such as nitinol wire rope. Each anchor 2,3 can include a first outer frame 122, 133 and a second outer frame 222, 233, respectively. In one embodiment, the proximal anchor 2 and distal anchor 3 can be substantially parallel to one another.

[0038] An exemplary proximal anchor 2 is shown in Figure 1C. The first outer frame 122 can sit proximal to the second outer frame 222, and the first outer frame 122 can sit in a plane substantially parallel to the plane of the second outer frame 222. Further, each frame 122, 222 can include a plurality of arcs 111, 211 (which can also be referred to as arcuate portions, curved portions, or petals), such as between 4 and 10 or between 5 and 8 arcs, joined together at joints 16, 26, respectively. For example, outer frame 122 can include six arcs 111a,b,c,d,e,f while outer frame 222 can also include six arcs 211a,b,c,d,e,f. The arcs 111 of the outer frame 122 can be connected together, and the arcs 211 of the outer frame 222 can be connected together, so as to form a substantially circular outer perimeter for each of the frames 122, 222.

[0039] Each joint 16, 26 between neighboring arcs 111 or 211 can be, for example, a crimp that crimps adjacent arcs (e.g., 111a and 111b) to one another. As shown in Figure

1C, the outer frames 122, 222 can be positioned relative to one another such that the arcs 111, 211 are out of phase relative to one another. For example, the arcs 111 can be approximately 90 degrees out of phase relative to the arcs 211. That is, the arcs 111 of the first outer frame 122 can overlap with the arcs 211 of the second outer frame 222 such that, for example, a single arc 111a of the first outer frame 122 overlaps with half of two underlying arcs 211f, 211a of the second outer frame 222. In some embodiments, only some arcs are out of phase with one another while other arcs are in-phase with one another. The second outer frames 133, 233 can likewise include arcs as described with respect to the first outer frame 122, 222.

10 [0040] As shown in Figures 1A and 1E, the first outer frame 122, 133 and the second outer frame 222, 233 of each anchor 2, 3 can be connected to one another through the central portion 4. The central portion 4 can extend from the crimps 16, 26 of the proximal anchor 2 to the corresponding crimps of the distal anchor 3. The central portion 4 can include substructures or wire segments 44 that form a pattern, such as a hexagonal pattern (see 15 Figure 1E). For example, two wire segments 44a,b of the central portion 4 can extend at an angle from the crimp 16a (see Figures 1D, 1E), such as to form an angle of approximately 120 degrees relative to one another. Each of the wire segments 44a,b can then meet adjacent wire segments within the central portion 4 (e.g., segment 44b meets segment 44c). The adjacent wire segments (e.g., 44b and 44c) can then be joined together at a joint 46 (e.g., 20 joint 46a). The joint 46a can form a column substantially parallel to a central axis 110 of the prosthesis 100. This pattern can extend throughout the entire prosthesis to form a number of joints 46, such as twelve joints 46. The joints 46 can not only fix the position of the outer frames of a single anchor together, but also fix the proximal and distal anchors 2, 3 together. The hexagonal structure of the segments 44 and joints 46 can advantageously provide radial and vertical strength as well as stability to the prosthesis 100.

[0041] In some embodiments (as shown in Figure 1D), parts of the central portion 4 can be formed of the same wire or wire rope as the outer frames of the anchors 2,3 and/or the outer frames of the anchors 2,3 can be formed of the same wire or wire rope as one another. For example, two single strands of wire, such as two 22-inch long strands of wire, can be 30 used to form the anchors 2, 3 and the central portion 4. As shown in Figures 1D and 1E, a single strand 191 (darkened in the picture relative to the opposite strand 193 for clarity) can form an arc 111a (see Figure 1D) of the first outer frame 122 of proximal anchor 2, extend through a joint 16a to form wire segment 44b of the central portion 4, extend through joint 46a to form wire segment 44d (see Figure 1D), then form an arch of the second outer frame

233, extend through another joint to form wire segment 44e (see Figure 1D), extend around in a similar fashion to form wire segment 44f (see Figure 1D), and continue winding in a similar fashion until all of the outer frames 122, 233 have been formed from the single strand 191. The ends of the strand 191 can then be attached to one another, such as through splicing
5 crimps, butt joint crimps, welding, riveting, or weaving. The second strand 193 can be wound similarly to form the second outer frame 222 of the proximal anchor 2 and the first outer frame 133 of the distal anchor 3.

[0042] By joining the first outer frame 122, 133 to the second outer frame 222, 233 of each anchor 2, 3, as described above, the arcs of each outer frame can be movable relative to
10 one another. For example, the arc 111a can be movable relative to the arcs 211f, 211a that it overlaps (see Figure 1C). That is, the outer perimeter of the arc 111a can flex along the central axis and/or translate relative to the arcs 211f, 211a (while the inner perimeter is fixed at the joints 46).

[0043] Advantageously, the large arc structure of the anchors can provide flexibility and
15 compliance for the portions of the prosthesis intended to be placed in the chambers of the heart. In contrast, in the stiffer tissue of the valve orifice, the hexagonal sub-structures of the central portion can provide higher radial stiffness and strength.

[0044] Further, by using wire rope, the prosthesis can advantageously be foldable and strong while the individual fibers, because they are small in diameter, can maintain resistance
20 to fatigue and fracture. In some embodiments, the two frames of a single anchor can be formed of wire rope of opposite lays. For example, the wire of one frame (e.g. strand 193) can be made of a rope twisted to the left while the wire of another frame (e.g. strand 191) can be made of a rope twisted to the right. Using wires of opposite lays can allow the wires to compensate for one another as they compress, thereby maintaining relative positioning
25 during expansion or contraction/folding of the device (as opposed to twisting of the entire device). Various possibilities for winding the wire rope are shown in Figures 8A-9B.

[0045] As shown in Figures 1A and 1E, struts 5 can extend distally from the distal anchor 3 and/or the central portion 4 and be configured to hold leaflets (shown in Figures 2A-2C). The struts 5 can be formed, for example, of wire rope. Further, in one example,
30 each strut 5 can include a plurality of wire components 55, such as three wire components 55. Each of the three wire components 55 of a single strut 5 can extend from neighboring joints 46 and come together at a joint 56, thereby forming triangular struts 5. In some embodiments, additional supporting structures, such as tubes, can be placed over or around

the struts to increase the stiffness. The triangular struts 5 can provide vertical strength and lateral flexibility.

[0046] In one embodiment, there can be three struts 5 located approximately 120 degrees away from one another around the circumference of the prosthesis 100. The joints 56 can be, for example, crimps. As shown in Figures 1A and 1E, in one embodiment, the center strut member 55a of a three-strut support can be substantially straight and connected to two outside, curved strut members 55b, 55c to form a structure comprised of two substantially triangular sub-structures, each with the center member as a common triangle leg. This center member may be made of a thin element of material which provides strength in tension as the pressurized leaflets are pushed toward the center of the valve, while providing flexion in compression to allow the valve prosthesis to be folded for delivery and to allow the prosthesis to conform to tissue when placed within the heart.

[0047] The various crimps used for the joints of the prosthesis 100 may be made of a suitable implantable material, such as platinum, tantalum, or titanium. Further, in place of crimps, braids, weaves, or welding can be used.

[0048] Referring to Figures 2A-2C, the valve prosthesis 100 can include integral valve leaflets 511 attached, such as sewn, to the struts 5. There can be three integral valve leaflets 511, and the leaflets 511 can form a pressure actuated valve that provides uni-directional flow occlusion when the prosthesis 100 is implanted in a valve orifice. The leaflets can be constructed of bio-materials, such as bovine or porcine pericardium, or polymer materials.

[0049] In one embodiment (shown in Figures 2B-2C), the proximal anchor 2 can include a cover or skirt 12 thereon or therearound formed of a biomaterial or thin polymer material. The skirt 12 can advantageously help seal the prosthesis 100 against the cardiac tissue when implanted.

[0050] The prosthesis 100 can be configured to be placed in a cardiac valve orifice such that the central portion 4 lines the orifice while the proximal and distal anchors 2, 3 sit within the chambers of the heart and pinch tissue of the orifice therebetween.

[0051] In some embodiments, the prosthesis 100 can be sized and configured for use in the mitral valve orifice (shown in Figure 6D). Referring to Figures 3A-3B, to ensure that the prosthesis 100 fits properly within the valve, the diameter d_o of the central opening 15 can be greater than a length ℓ of the device when fully expanded. For example, the ratio d_o/ℓ can be greater than or equal to 1.1, such as greater than or equal to 1.2 or greater than or equal to 1.3. Further, the ratio d_o/ℓ can be less than 2.0. In one embodiment, the diameter d_o is between 25mm and 40mm, such as approximately 28mm. Further, in one embodiment, the

length ℓ is less than or equal to 22mm, or less than or equal to 20mm, such as approximately 14mm. Further, to ensure that the proximal and distal anchors have enough tissue to grab onto, a ratio of the outer diameter of the anchors, d_T , to the length ℓ can be greater than or equal to 2.0. In one embodiment, an outer diameter of anchors, d_T , can be at least 38mm, such as greater than or equal to 40mm. Further, in one embodiment, the anchors can extend out at a radius r_a of greater than 10mm, such as approximately 12mm. Finally, a ratio d_o to a length of the struts ℓ_s can be approximately 1.5 to 3.0, such as 2.1. A ratio of d_o/ℓ_s within this range can advantageously ensure that there is enough leaflet material to allow the leaflets to oppose and seal under stress while maintaining a small enough length to fit properly within the valve. In one embodiment, the struts have a length ℓ_s of between 8 and 16mm, such as approximately 14mm. Further, ℓ_c can be approximately 4-10mm, such as 6mm.

[0052] In one exemplary embodiment, d_o is 28mm, r_a is 12mm, ℓ_c is 6mm, ℓ_s is 14mm, d_T is 40mm, and ℓ is 14mm.

[0053] Figures 4A-4B show a closed delivery device 200 for delivery of a valve prosthesis 100. The delivery device 200 can include an outer sheath 13 and a multi-lumen central longitudinal structure 17 extending therethrough. The valve prosthesis 100 is configured to fit over the central longitudinal structure 17 and within the sheath 13 so as to be fully encapsulated within the delivery device 200. The lumens in the longitudinal structure 17 can be tubular structures 357 (see Figures 4B and 5C). Each tubular structure 357 can include a side lumen 355 (see Figures 4B and 10A) therein, i.e., an aperture disposed on a radial outer portion of the tubular wall. The tubular structures 357 can contain retention members 19 that bind the proximal anchor 2 of the valve prosthesis tightly to the longitudinal structure 17. The retention members 19 can be made, for example, of a strong, flexible material such as nitinol, nitinol wire rope, or liquid crystal polymer fiber, such as Vectran®. There can be various numbers of retention wires and corresponding tubes 357 and lumens, such as between 4 and 20 or between 6 and 12 retention wires and corresponding tubes/lumens. In one embodiment, there are six retention wires and lumens. In another, there are twelve retention wires and lumens. The delivery device 200 includes a central lumen 15 running therethrough (i.e., through the central longitudinal structure 17) configured to pass a standard cardiac guidewire 16. The guidewire 16 may be used to provide a safe pathway for getting the device 100 to the anatomical target. The delivery device 200 further includes a tapered tip 14 to provide a gradual, atraumatic transition from the guidewire to the outer sheath 13 of the delivery device 200.

[0054] In some embodiments, the delivery device 200 can be adapted to specific delivery paths and cardiac structures by being provided with pre-shaped bends in the outer sheath 13. In some embodiments, the delivery device 200 may contain pull-wires integral with the outer wall that may be tensioned to articulate and bend the outer sheath 13. The pull
5 wires may terminate at the tip of the device to provide a bend starting at the distal tip or may terminate along the longitudinal shaft of the device to provide a more proximal bend location.

[0055] Figures 5A-5D show a multi-stage delivery system for a cardiac valve prosthesis (with the valve leaflets omitted from the drawings for clarity). Figure 5A shows the delivery
10 device 200 having a handle 300 connected thereto to control the delivery of a prosthesis loaded within the device.

[0056] Figures 5B and 5C shows the prosthesis 100 partially deployed. That is, as the sheath 13 is pulled back with a lever 301 on the handle 300, the distal anchor 3 (previously collapsed into the sheath 11 with the peaks of the arcs extending distally) pops open. The
15 proximal anchor 2, in turn, can remain connected to the delivery device 100 via the retention wires 19. That is, the retention wires 19 can pass through the multi-lumen central structure 17, through the arcs of the outer frame 122, 222 at apertures 355, and back into lumens of the structure 17. Referring to Figures 10A and 12A, in one embodiment, the proximal anchor 2 can be connected to the retention wires 19 such that neighboring arcs 111a, 211a of the
20 proximal anchor 2 extend over neighboring retention wires 19a, 19b. In other embodiments (as shown in Figure 12B), two neighboring arcs 111a, 211a can extend over a single retention wire 19a. Referring back to Figures 5B and 5C, as the retention wires 19 are pulled tight, the peaks of the arcs of the proximal anchor 2 will be pulled proximally, thereby causing the proximal anchor 2 to fold or cinch up to form a funnel shape at the proximal end of the distal
25 anchor 3 (crimps 16, 26 of the proximal anchor 2 can be seen).

[0057] To expand the proximal anchor 2, the wires 19 can either be withdrawn or loosened (such as with a lever 303 on the handle), thereby allowing the proximal anchor 2 to self-expand into place, as shown in Figure 5D. Referring to Figures 10A-10B, in some
30 embodiments, the wires 19a can be withdrawn completely, thereby allowing the proximal anchor 2 to expand. In another embodiment, shown in Figures 11A-11B, the retention wires 19 can be formed of loops that, when loosened, i.e. pushed distally, allow the distal anchor 2 to expand without releasing the anchor 2. By using such a mechanism, the proximal anchor can be resheathed and moved (by retightening the retention members 19) if necessary. A mechanism on the handle can then be used to release the retention members 19 entirely.

[0058] Referring to Figure 6A, to deploy the valve prosthesis 100 in a valve (such as the mitral valve), the guidewire 16 and delivery device 200 can be inserted through the native valve. Referring to Figure 6B, as the outer sheath 13 of the device 200 is retracted relative to the central longitudinal structure 17, the distal anchor 3 of the valve prosthesis is exposed and self-expands (such as into the left ventricle). Once expanded, the distal anchor 3 may be retracted proximally against the distal-facing tissue of the cardiac chamber around the orifice, providing positive tactile feedback that the distal anchor 3 is oriented and positioned properly against the distal wall of the cardiac orifice. Further retraction of the sheath 13 exposes the central portion 4 of the valve prosthesis, allowing the central portion 4 to radially expand against the inner wall of the cardiac orifice.

[0059] Referring to Figure 6C, to expand the prosthesis 100 on the other side of the cardiac orifice (i.e., in the left atrium), the central retention members 19 of the delivery device can be withdrawn or loosened as described above, thereby expanding the proximal anchor 2. The expanded proximal anchor 2 provides a second backstop to the valve prosthesis 100, allowing the prosthesis 100 to sandwich the valve orifice, such as the mitral valve orifice between the proximal and distal anchors 2, 3. As the device 100 expands, it foreshortens, moving the proximal anchor 2 and distal anchor 3 toward each other to provide a compressive force on tissue surrounding the cardiac orifice, such as the valve annulus.

[0060] Thus, in one example, as shown in Figure 6D, the prosthesis can be delivered into the mitral valve orifice such that the distal anchor 3 sits within the left ventricle while the proximal anchor 2 sits within the left atrium. The struts 5 and leaflets 511 can extend distally into the left ventricle. Tissue of the mitral valve annulus can be captured between the anchors 2, 3. Further, the size of the prosthesis 100 can be such that the anchors 2, 3 extend within the chambers of the heart and much wider than the diameter of the orifice itself, thereby allowing for strong tissue capture and anchoring. In some embodiments, placement of the prosthesis can move the existing leaflets valves out of the way.

[0061] In some embodiments, as described above, the valve prosthesis 100 can be repositioned using the delivery device 200. That is, by pulling on the retention wires 19, the proximal anchor 2 can be cinched back down with the proximal arcs extending proximally. The distal anchor 3 can be collapsed into the sheath (with the arcs extending distally) either by pulling proximally on the prosthesis 100 or pushing the sheath 13 distally.

[0062] Use of an alternative delivery device is shown in Figure 13. As shown in Figure 13, rather than including multiple retention wires, the delivery device can include a single elongate member 96 over which all of the arcs 111, 211 of the proximal anchor 2 are placed.

[0063] Figure 7 shows an embodiment of the valve prosthesis 199 where retention hooks 21 are built into the device. The hooks 21 extend from toward the center of the device from the joints (e.g., crimps) of the distal anchor 3. The hooks may be made of nitinol and are curved so that as the distal anchor 3 is drawn toward the center longitudinal member 17 of the delivery device 200, the hooks flatten and collapse, allowing the outer sheath 13 of the delivery device 200 to slide smoothly over the hooks 21. As the outer sheath 13 is removed from the valve prosthesis 100 during delivery and the distal anchor 3 of the valve prosthesis opens, the hooks 21 expand into the tissue of the cardiac orifice. In embodiment, the hooks 21 are only located on the distal anchor 3, as the distal anchor 3, when located on the ventricular side of the aorta, undergoes the highest pressure. In other embodiments, the hooks 21 are located on the proximal anchor 2 and/or the central portion 4.

[0064] In one embodiment, small hooks in the distal anchor 3 may be used to grip the valve leaflets. As the distal anchor 3 is retracted from the ventricle toward the mitral valve annulus, the hooks can pull the leaflets into a folded position just under the ventricular side of the mitral annulus.

[0065] While preferred embodiments of the present invention have been shown and described herein, it will be obvious to those skilled in the art that such embodiments are provided by way of example only. Numerous variations, changes, and substitutions will now occur to those skilled in the art without departing from the invention. It should be understood that various alternatives to the embodiments of the invention described herein may be employed in practicing the invention. It is intended that the following claims define the scope of the invention and that methods and structures within the scope of these claims and their equivalents be covered thereby.

CLAIMS

What is claimed is:

1. A prosthetic mitral valve comprising:

a proximal anchor, a distal anchor, and a central portion therebetween;

5 wherein the proximal and distal anchors each comprise a first outer frame and a second outer frame,

the first outer frame comprising a plurality of first arcs joined together, and

the second outer frame comprising a plurality of second arcs joined together,

wherein the plurality of first arcs are out of phase relative to the plurality of second arcs.

10

2. The prosthetic mitral valve of claim 1, wherein the first plurality of arcs are movable relative to the second plurality of arcs.

3. The prosthetic mitral valve of claim 1, wherein the first and second outer frames
15 are substantially circular.

4. The prosthetic mitral valve of claim 1, wherein the plurality of first arcs are disposed around substantially the entire first outer frame, and wherein the plurality of second arcs are disposed around substantially the entire second outer frame.

20

5. The prosthetic mitral valve of claim 1, wherein the plurality of first arcs lie substantially in a first plane, and wherein the plurality of second arcs lie substantially in an adjacent second plane.

25

6. The prosthetic mitral valve of claim 1, wherein the first and second arcs are approximately 90 degrees out of phase.

7. The prosthetic mitral valve of claim 1, wherein the first and second outer frames are made of wire rope.

30

8. The prosthetic mitral valve of claim 1 wherein the wire rope of the first outer frame has an opposite lay than a lay of the wire rope of the second outer frame.

9. The prosthetic mitral valve of claim 1, wherein the proximal anchor and distal anchor are substantially parallel to one another.

10. The prosthetic mitral valve of claim 1, wherein the central portion includes substructures connecting the proximal and distal anchors.

11. The prosthetic mitral valve of claim 10, wherein the substructures are hexagonal.

12. The prosthetic mitral valve of claim 1, wherein the proximal anchor, distal anchor, and central portion are configured to expand from a constrained configuration to an expanded configuration.

13. The prosthetic mitral valve of claim 12, wherein the device is configured to foreshorten upon expansion of the proximal anchor, distal anchor, and central portion from the constrained configuration to the expanded configuration.

14. The prosthetic mitral valve of claim 1, wherein the proximal anchor and the distal anchor each have a diameter in the expanded configuration that is greater than a diameter of the central portion in the expanded configuration.

15. A prosthetic mitral valve comprising:
a valve frame comprising a proximal anchor, a distal anchor, and a central portion therebetween, the valve frame configured to expand from a constrained configuration to an expanded configuration;
a plurality of struts attached to the central portion and extending distally past the distal anchor; and
a plurality of leaflets secured to the plurality of struts such that at least a portion of each leaflet extends distally past the distal anchor.

16. The prosthetic mitral valve of claim 15, wherein the valve frame is configured to self-expand.

17. The prosthetic mitral valve of claim 15, wherein the plurality of leaflets are further attached to the central portion.

18. The prosthetic mitral valve of claim 15, wherein the plurality of leaflets comprise a biomaterial or a polymer.

19. The prosthetic mitral valve of claim 15, wherein the proximal anchor is covered with a skirt configured to seal the prosthetic valve.

20. The prosthetic mitral valve of claim 19, wherein the skirt comprises a biomaterial or polymer.

21. The prosthetic mitral valve of claim 15, wherein an outer perimeter of the proximal anchor is substantially circular when covered with the skirt.

22. The prosthetic mitral valve of claim 15, wherein the plurality of leaflets are arranged to fill an inner diameter of the mitral valve prosthetic.

23. The prosthetic mitral valve of claim 22, wherein a ratio of the inner diameter to a height of the plurality of struts is approximately 2:1.

24. The prosthetic mitral valve of claim 15, wherein the valve frame is configured to foreshorten upon expansion of the valve frame from the constrained configuration to the expanded configuration.

25. The prosthetic mitral valve of claim 15, wherein the proximal anchor and the distal anchor each have a diameter in the expanded configuration that is greater than a diameter of the central portion in the expanded configuration.

26. A delivery device, comprising:
a central longitudinal structure having a plurality of tubes extending therethrough, each tube having a tubular wall and an aperture in the tubular wall;
a retention wire extending within each tube, each retention wire configured to extend through a portion of a medical device at the aperture;

a sheath configured to fit over and slide relative to the central longitudinal structure and the medical device;

a handle connected to the central longitudinal structure; and

5 a control on the handle configured to tighten the wires to collapse at least a portion of the medical device and to loosen the wires to expand the portion of the medical device.

27. The delivery device of claim 26, further comprising a central lumen extending through the central longitudinal structure, the central lumen configured to house a guidewire.

10 28. The delivery device of claim 26, wherein the retention wires are made of nitinol or liquid crystal polymer fiber.

29. The delivery device of claim 26, wherein there are between 4 and 20 retention wires and tubes.

15

30. The delivery device of claim 26, further comprising a tapered distal tip connected to the central longitudinal structure.

20 31. The delivery device of claim 26, wherein the control is further configured to retighten the wires after loosening to collapse the portion of the medical device again.

32. The delivery device of claim 26, wherein the aperture is a side aperture.

33. A method of delivering a prosthetic mitral valve comprising:

25 delivering a distal anchor from a delivery sheath such that the distal anchor self-expands inside a first heart chamber on a first side of the mitral valve annulus;

pulling proximally on the distal anchor such that the distal anchor self-aligns within the mitral valve annulus and the distal anchor rests against tissue of the ventricular heart chamber; and

30 delivering a proximal anchor from the delivery sheath to a second heart chamber on a second side of the mitral valve annulus such that the proximal anchor self-expands and moves towards the distal anchor to rest against tissue of the second heart chamber, the self-expansion of the proximal anchor capturing tissue of the mitral valve annulus therebetween.

34. The method of claim 33, wherein the first heart chamber is a ventricular heart chamber, and wherein the second heart chamber is an atrial heart chamber.

35. A method of delivering a prosthetic mitral valve comprising:

5 securing a prosthetic valve within a delivery device by extending a plurality of wires of the delivery device through a proximal anchor so as to collapse the proximal anchor;

 extending the prosthetic delivery device into a heart with the prosthetic valve covered by a sheath of the delivery device;

10 pulling the sheath proximally to expose a distal anchor of the prosthetic valve, thereby allowing the distal anchor to self-expand into place on a first side of the mitral valve annulus;

 pulling the sheath proximally to expose the proximal anchor;

 loosening the wires of the delivery device so as to allow the proximal anchor to self-expand into place on a second side of the mitral valve annulus; and

 removing the delivery device from the heart.

15

36. The method of claim 35, further comprising:

 tightening the wires after loosening the wires so as to collapse the proximal anchor again;

 repositioning the proximal anchor to a second location on the second side of the mitral valve annulus; and

20 loosening the wires of the delivery device so as to allow the proximal anchor to self-expand into place at the second location on the second side of the mitral valve annulus.

37. The method of claim 35, wherein extending a plurality of wires of the delivery device through a proximal anchor so as to collapse the proximal anchor comprises extending a plurality of wires through arcs of the proximal anchor.

25

38. The method of claim 37, wherein neighboring retention wires extend through neighboring arcs.

39. The method of claim 35, further comprising extending a guidewire down a central lumen of the delivery device before extending the prosthetic delivery device into the heart.

30

40. The method of claim 35, wherein tightening and loosening the wires of the delivery device is performed with a control on a handle of the delivery device.

41. A method of delivering a prosthetic mitral valve comprising:

providing a prosthetic valve within a delivery device such that a plurality of wires of the delivery device extend through a proximal anchor and maintain the proximal anchor in a collapsed configuration;

5 extending the prosthetic delivery device into a heart with the prosthetic valve covered by a sheath;

pulling the sheath proximally to expose a distal anchor of the prosthetic valve, thereby allowing the distal anchor to self-expand on a first side of the mitral valve annulus;

10 pulling the sheath proximally to expose the proximal anchor and maintaining a proximal end of the proximal anchor in a collapsed configuration after exposing the proximal anchor;

loosening the wires of the delivery device so as to allow the proximal anchor to self-expand on a second side of the mitral valve annulus, wherein loosening the wires occurs at a time after the sheath is pulled proximally to expose the proximal anchor and comprises retracting
15 distal ends of each of the plurality of wires from a position distal to a proximal end of the proximal anchor to a position proximal to the proximal end of the proximal anchor.

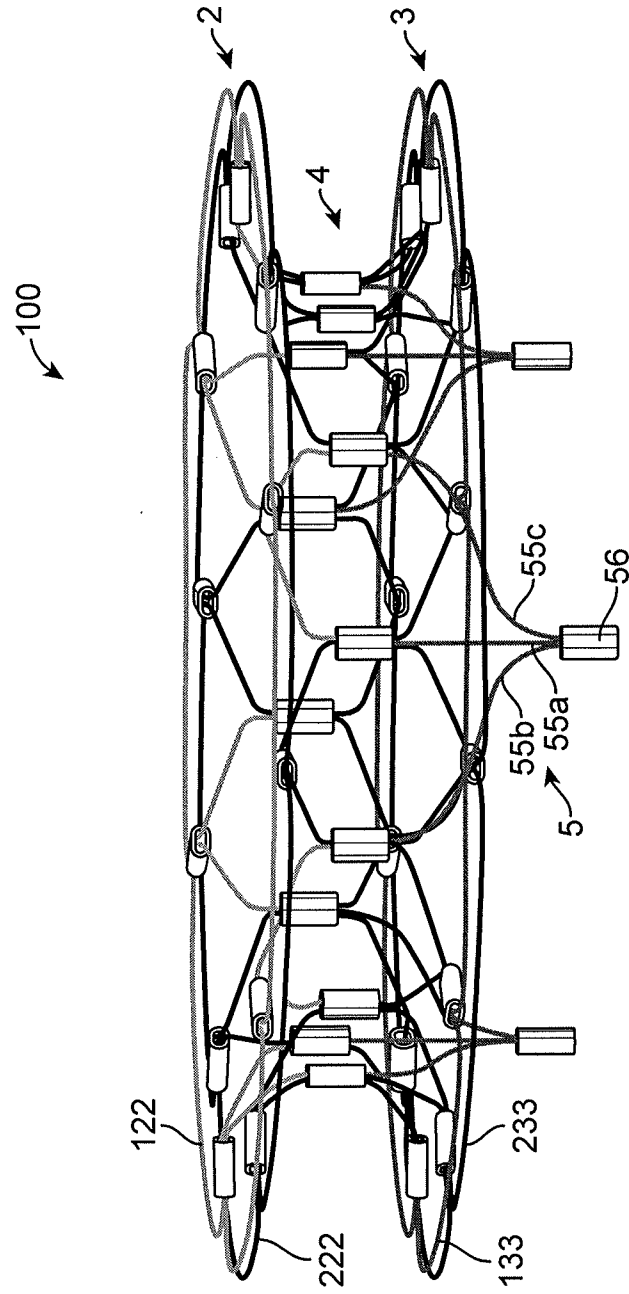

FIG. 1A

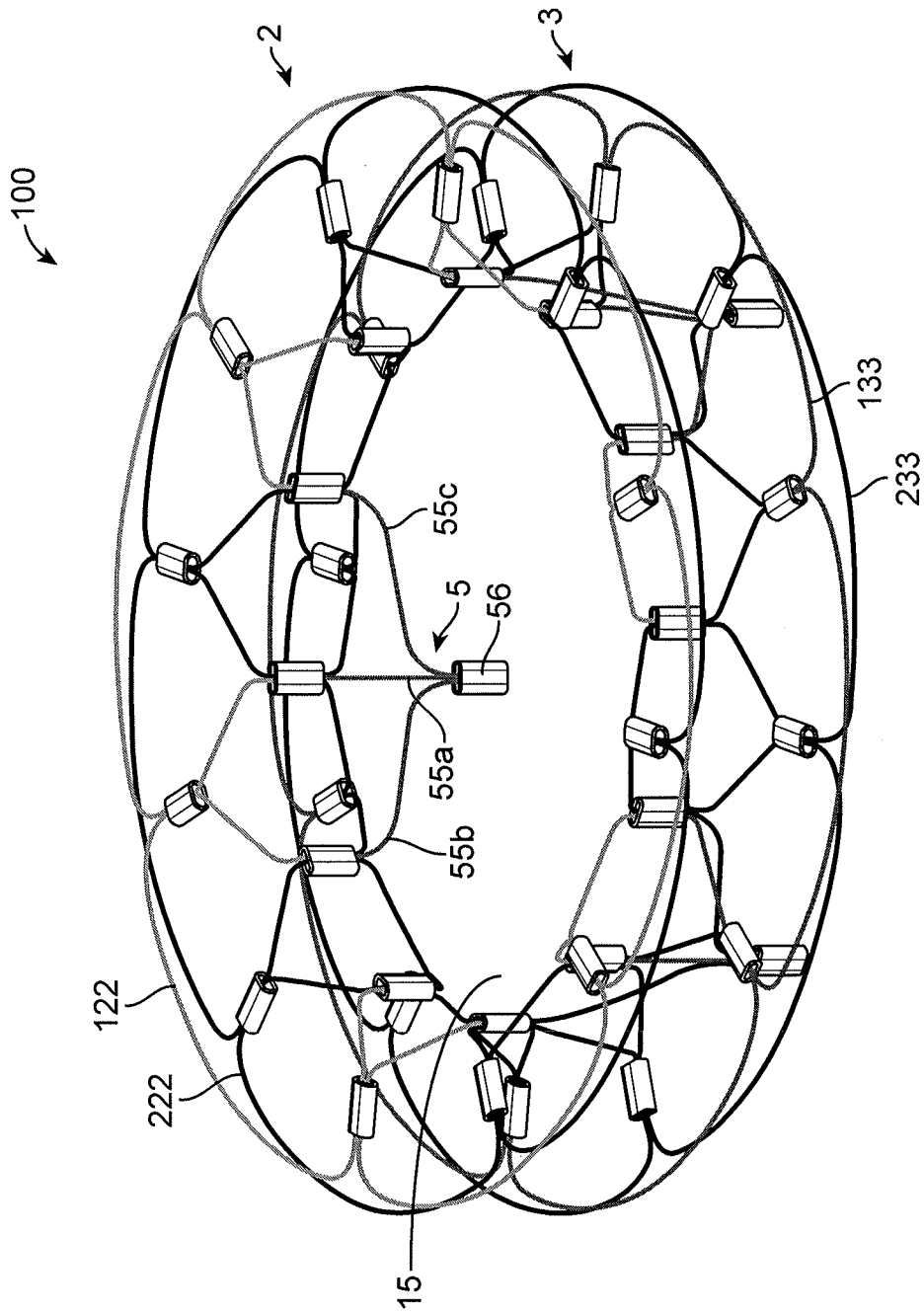

FIG. 1B

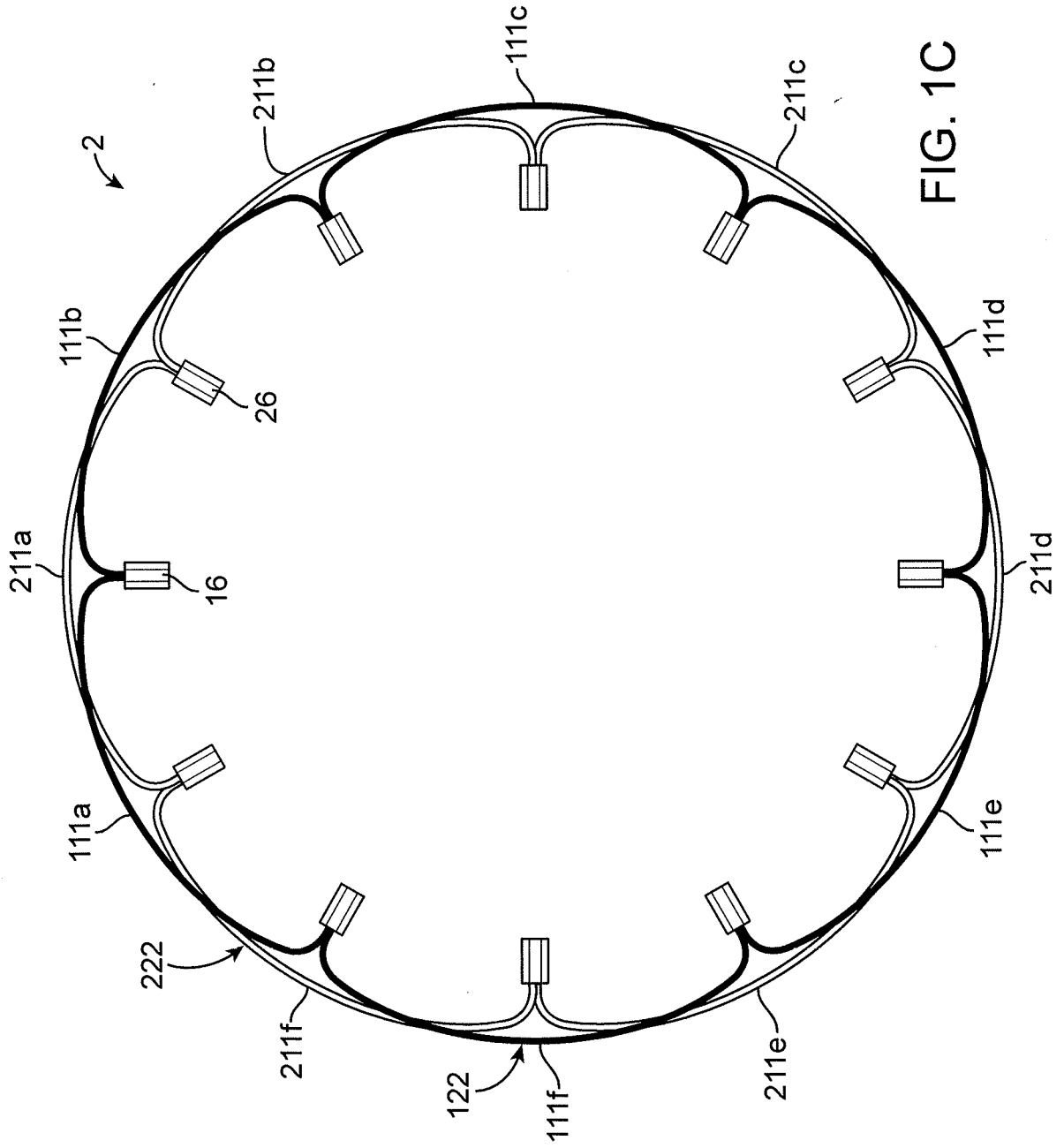

FIG. 1C

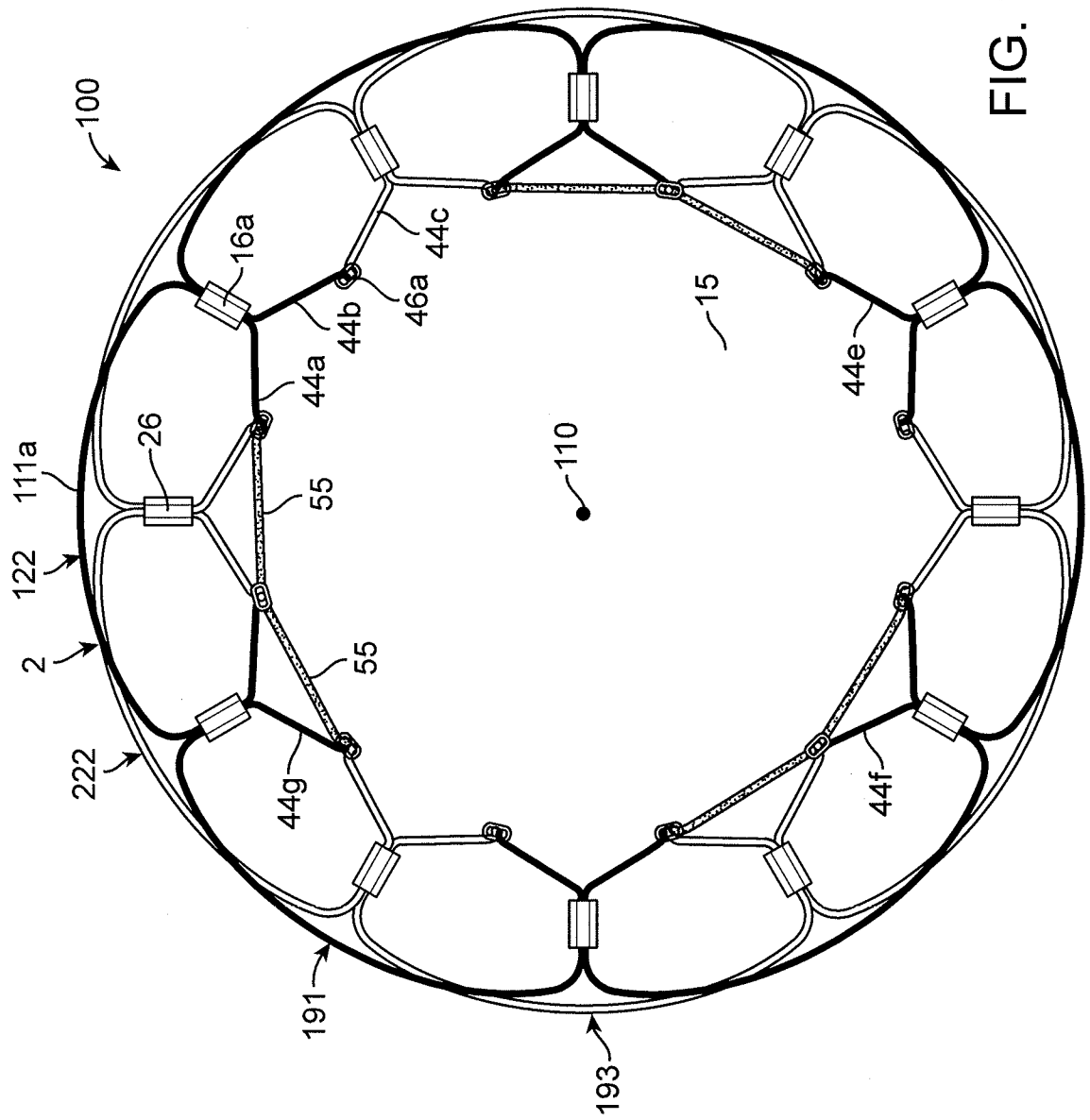

FIG. 1D

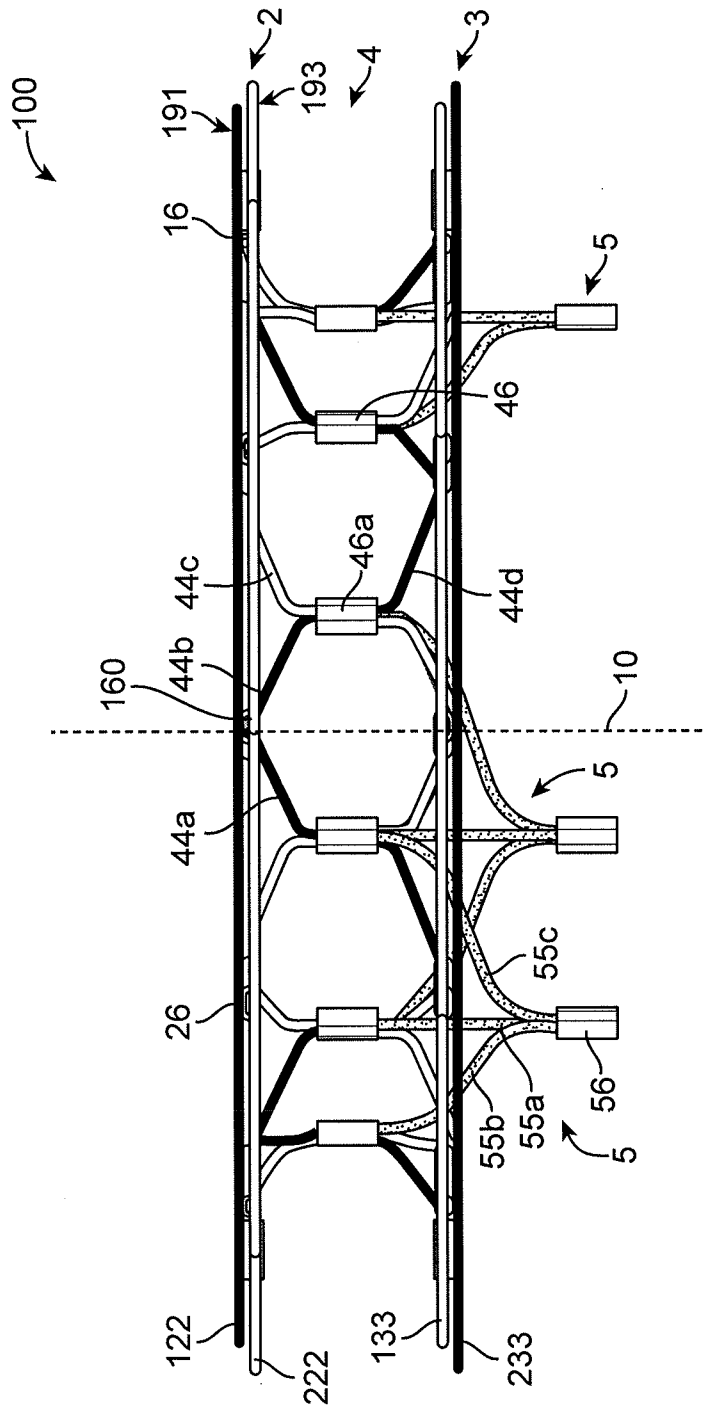

FIG. 1E

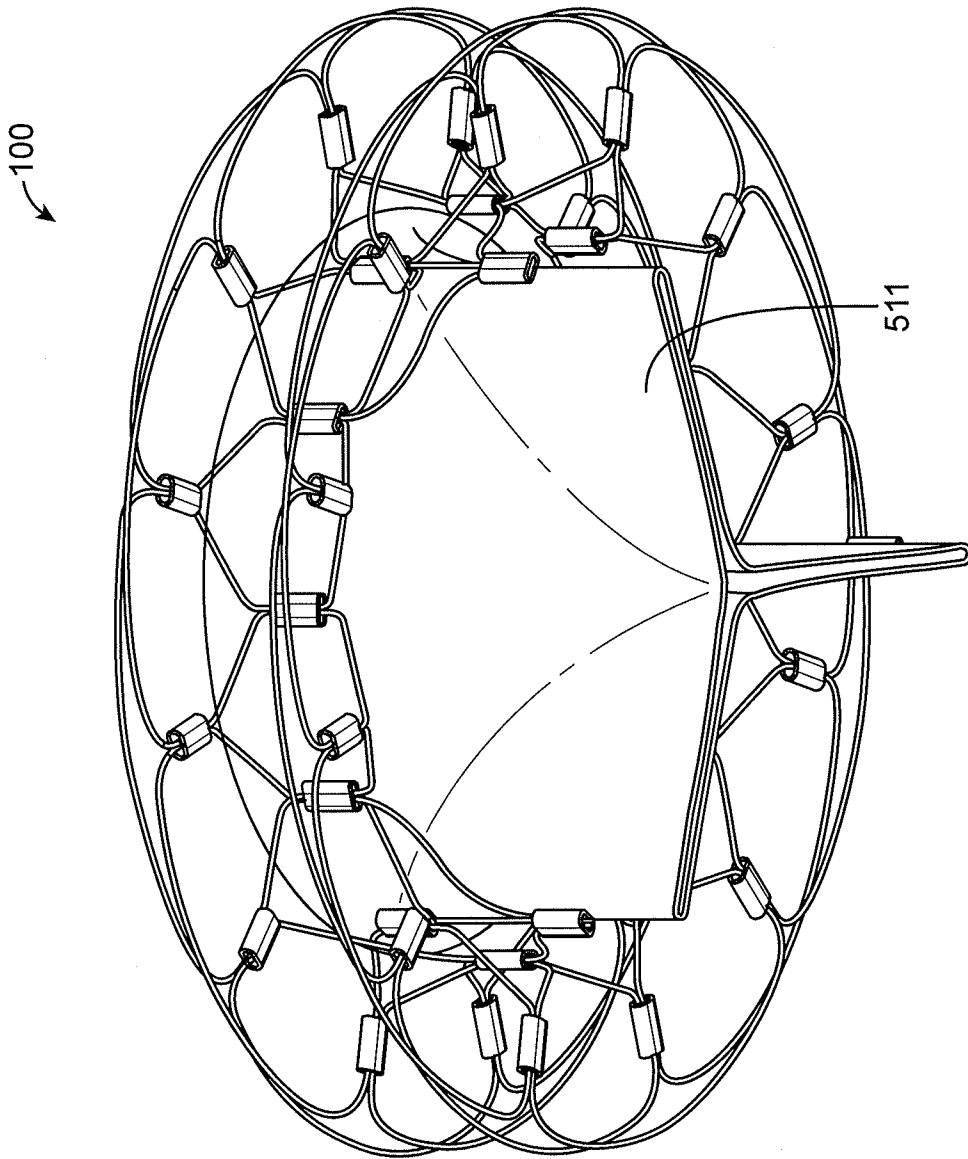

FIG. 2A

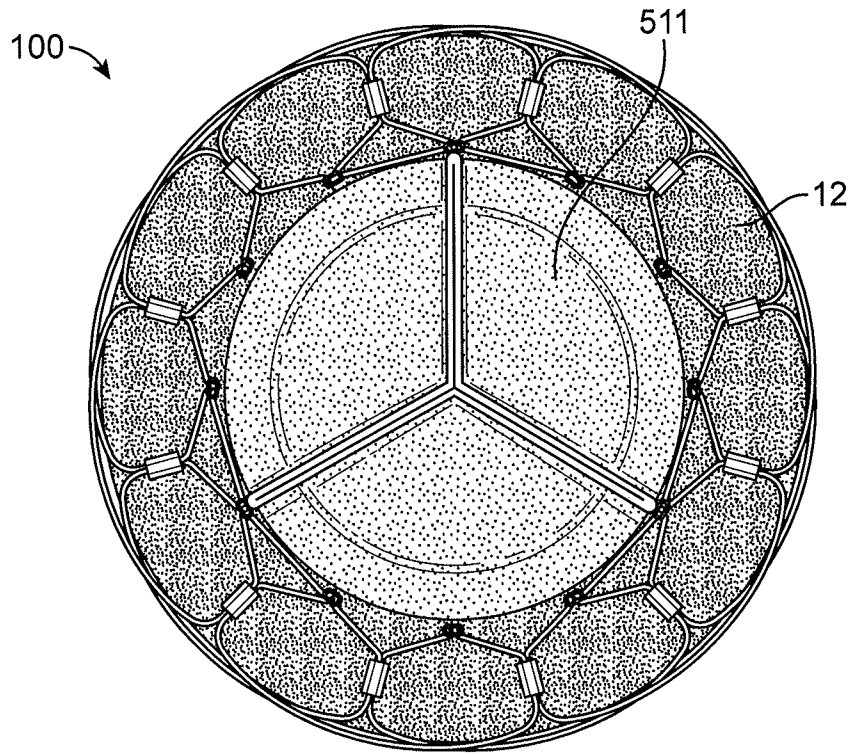

FIG. 2B

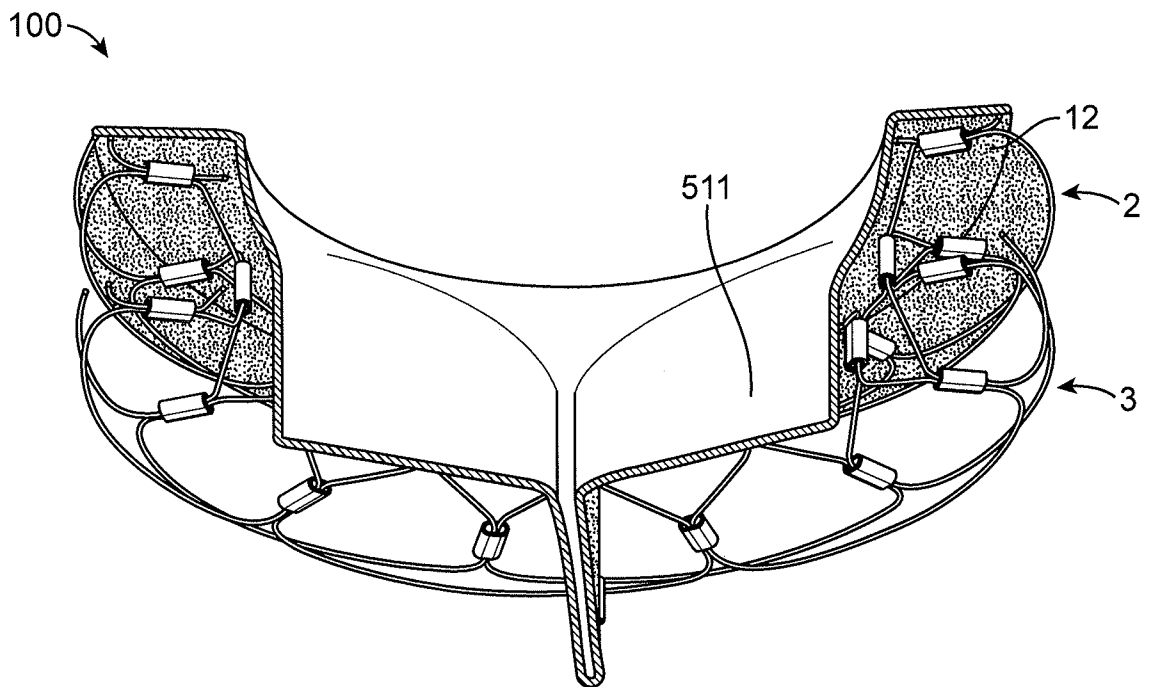

FIG. 2C

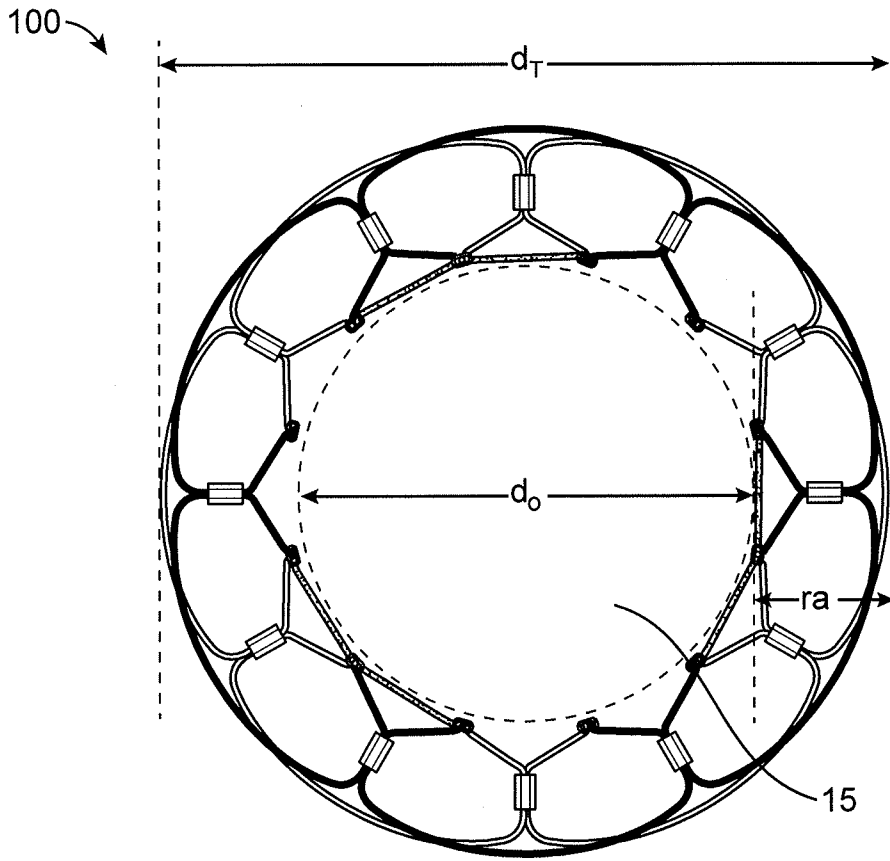

FIG. 3A

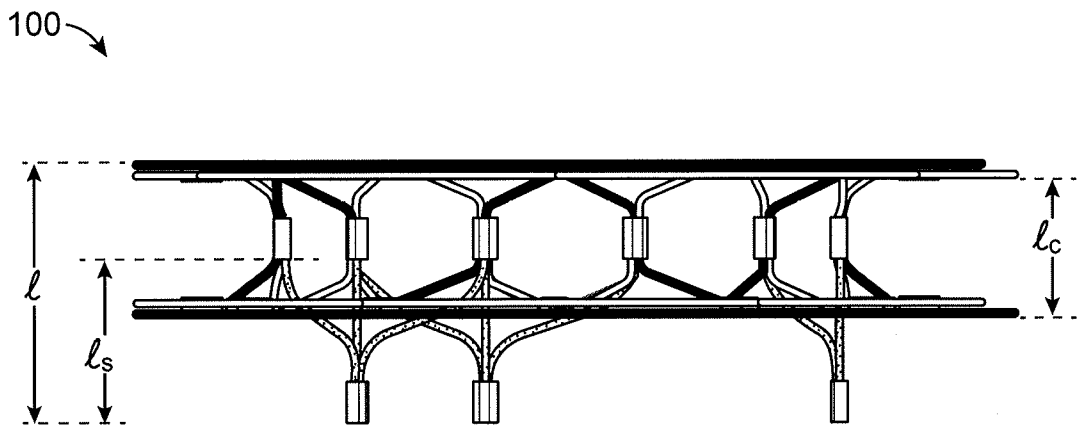

FIG. 3B

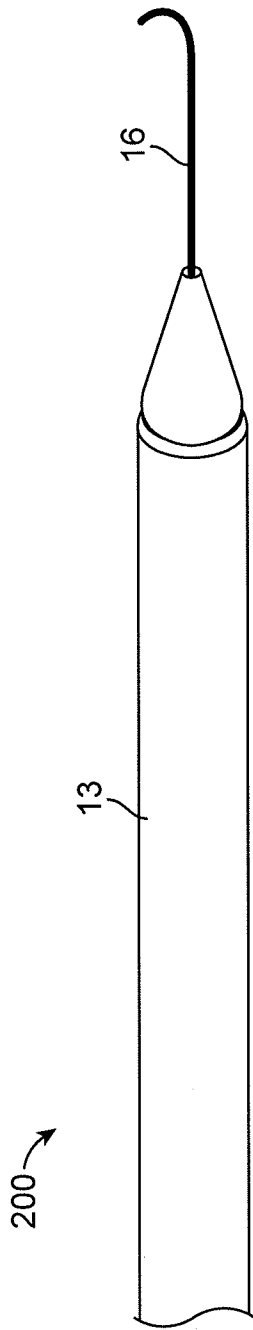

FIG. 4A

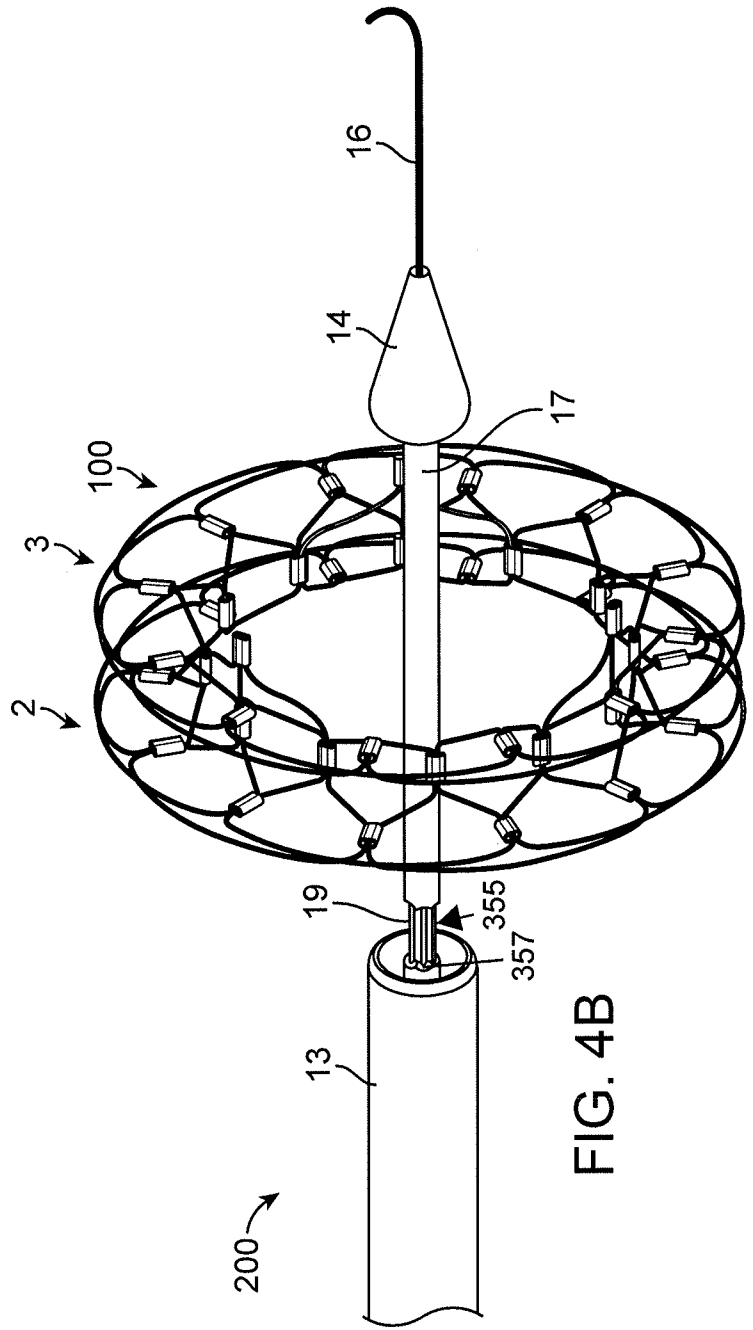

FIG. 4B

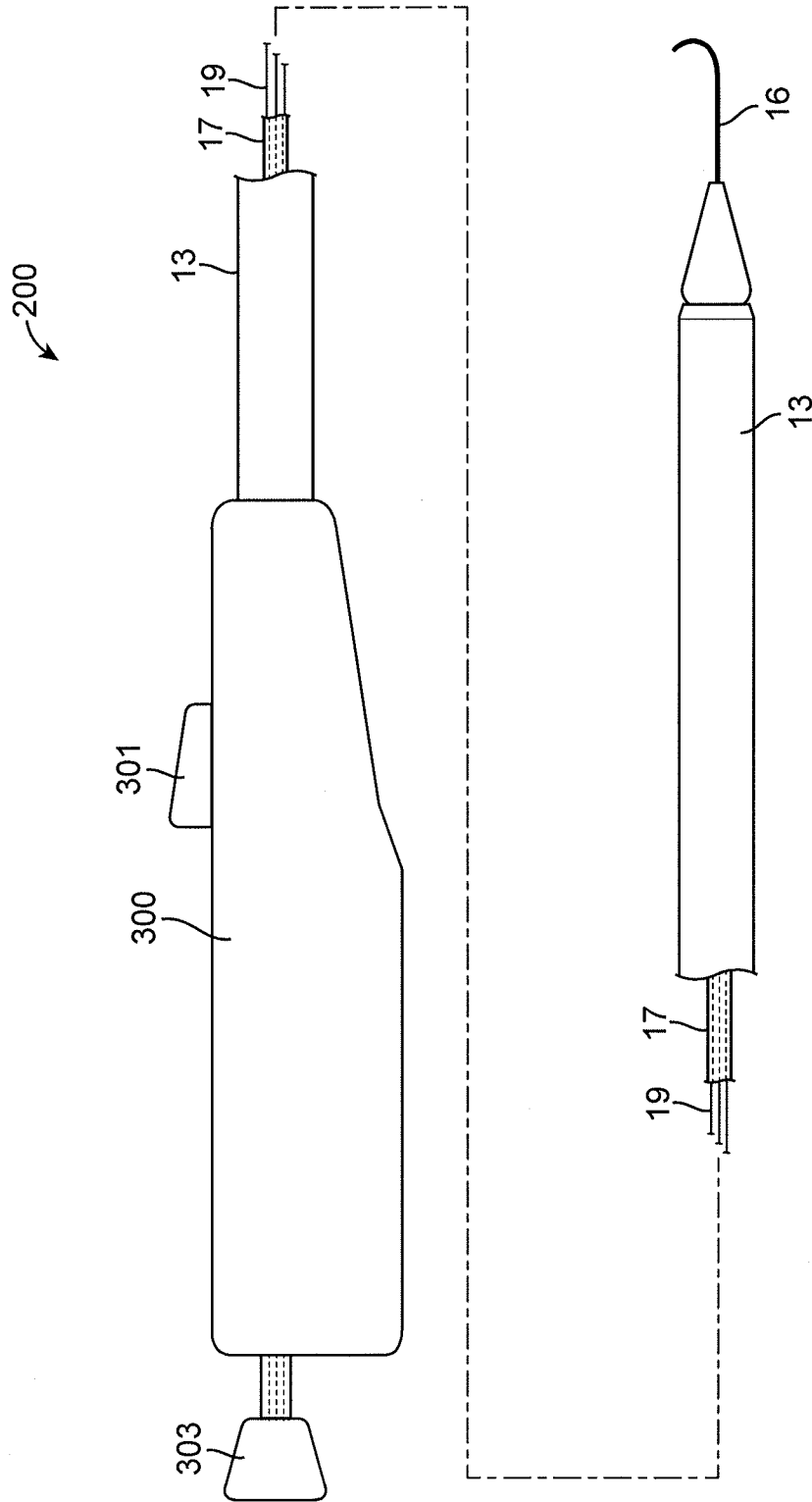

FIG. 5A

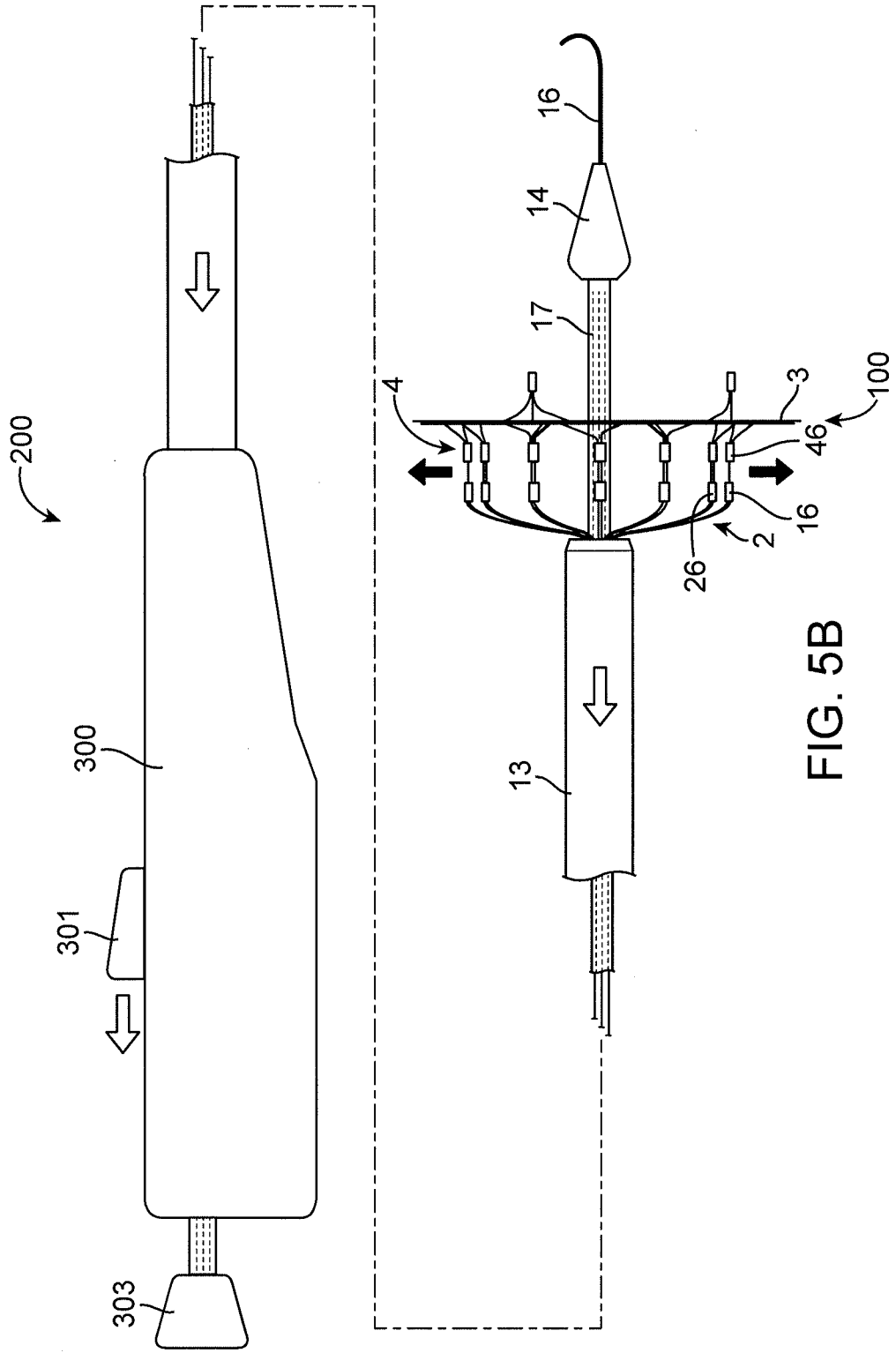

FIG. 5B

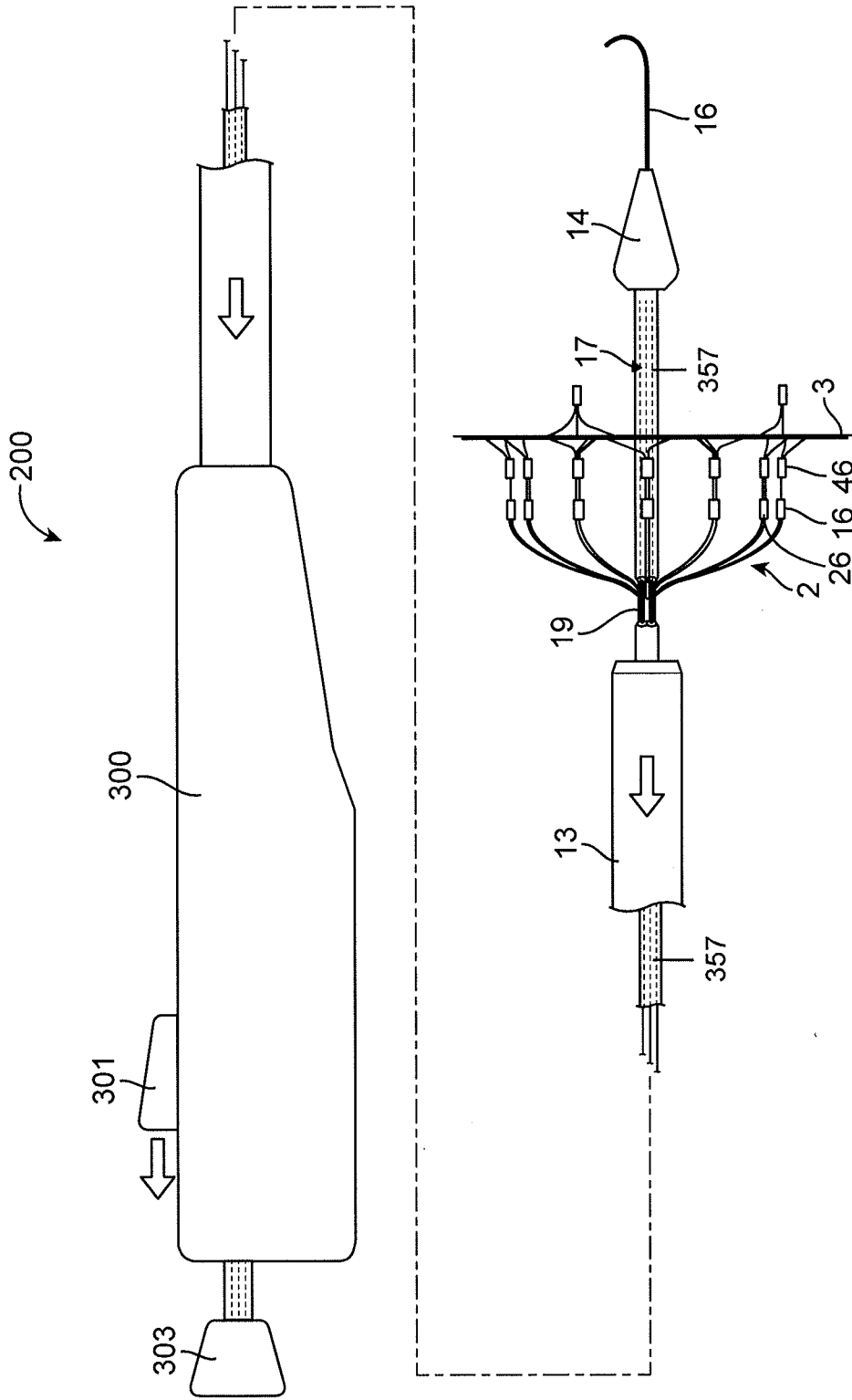
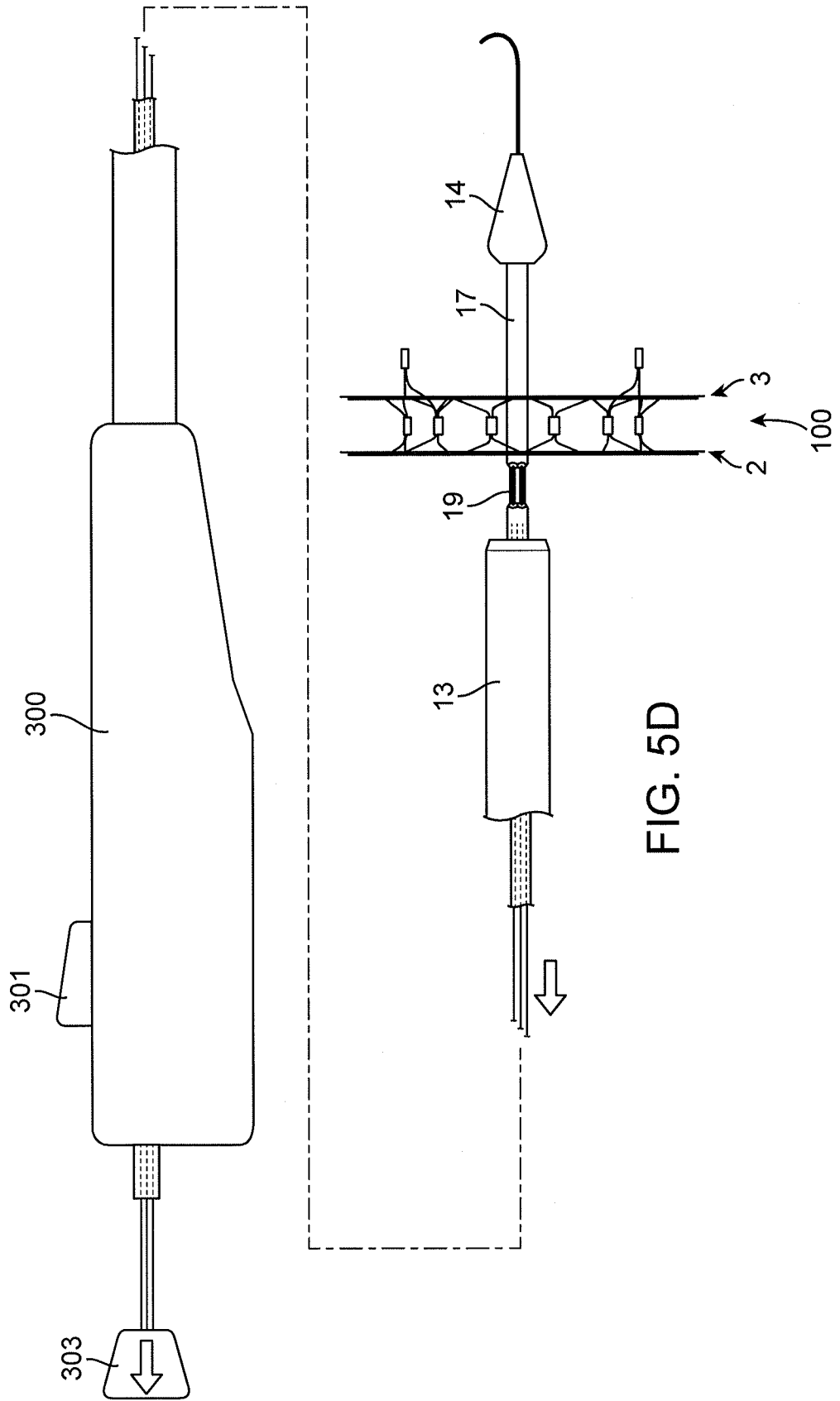

FIG. 5C



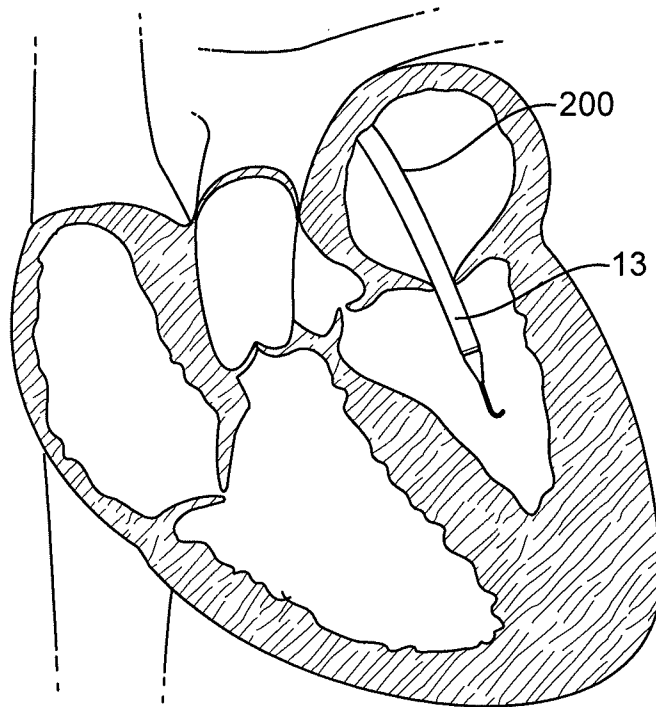

FIG. 6A

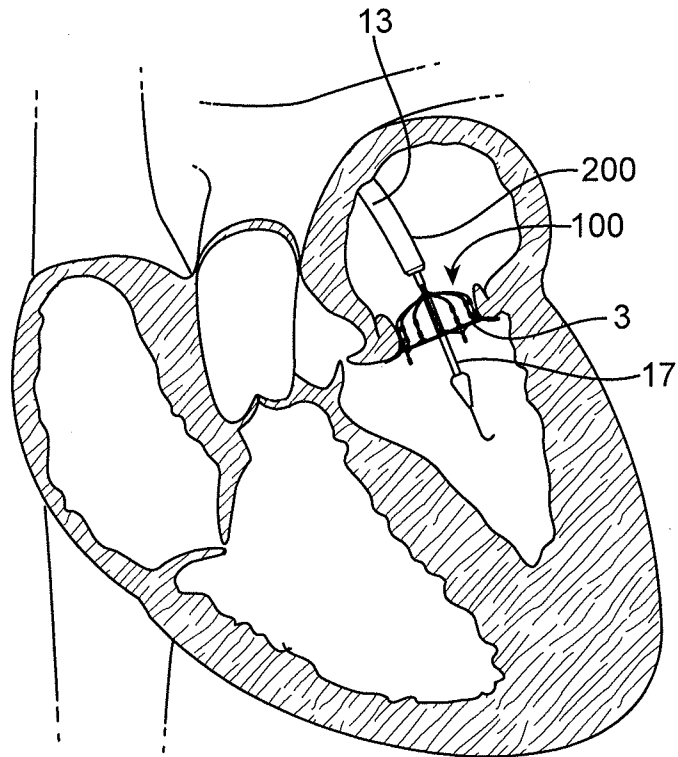

FIG. 6B

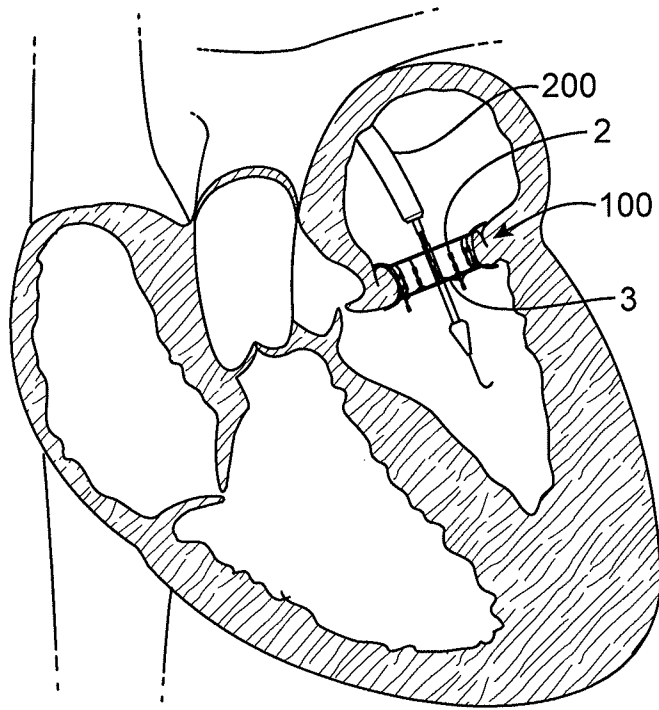

FIG. 6C

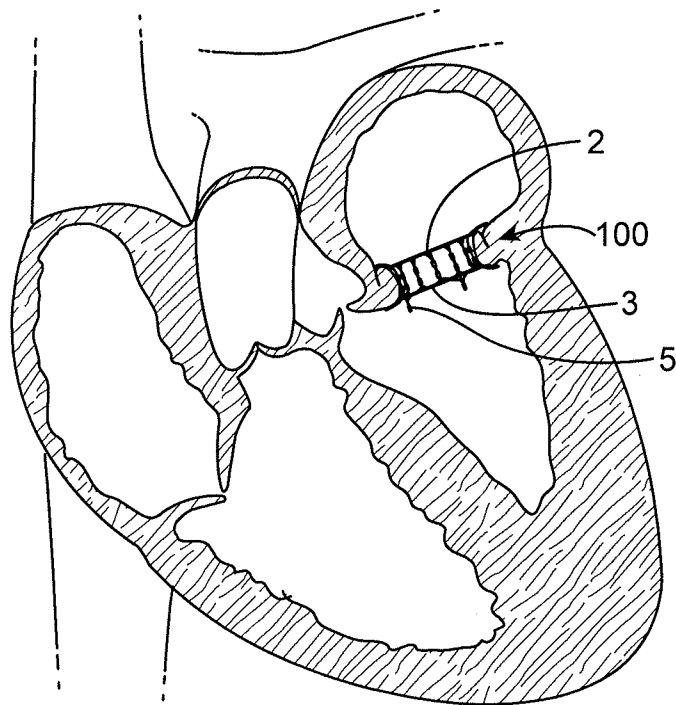

FIG. 6D

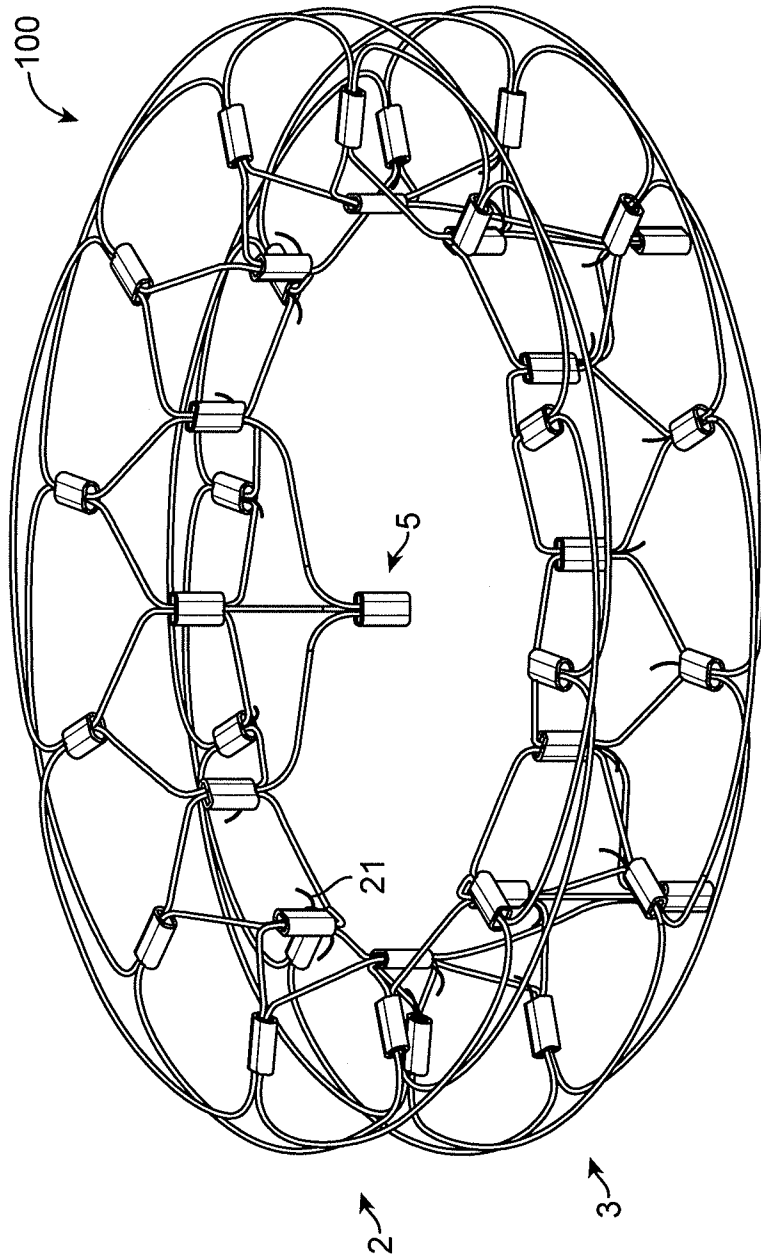

FIG. 7

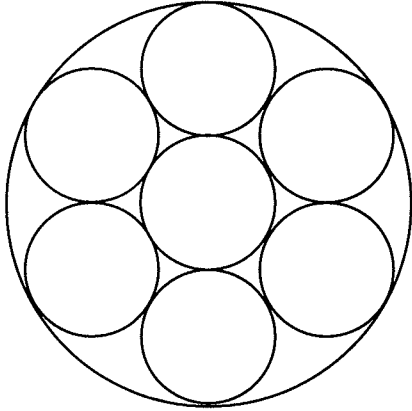

FIG. 8B

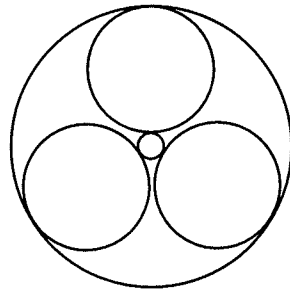

FIG. 9B

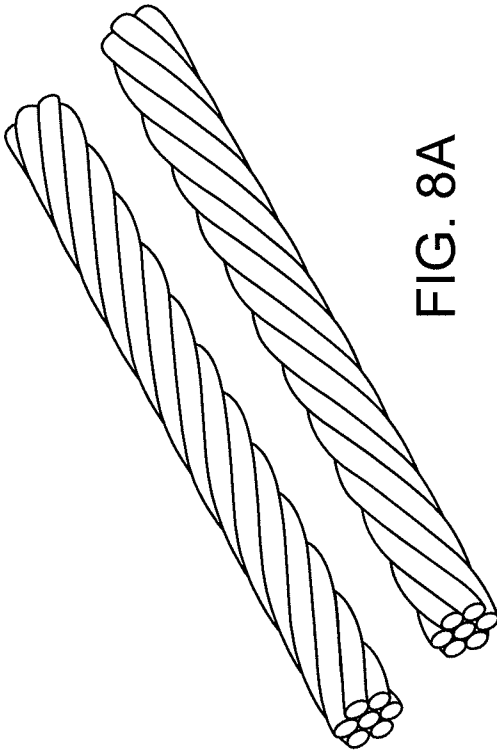

FIG. 8A

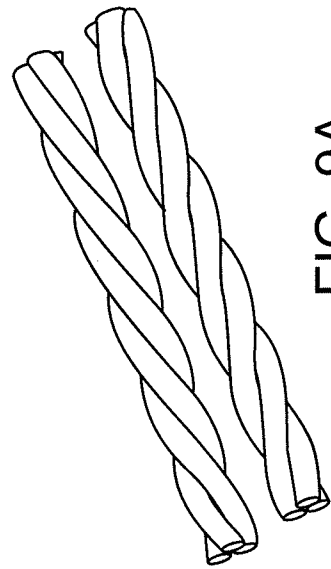

FIG. 9A

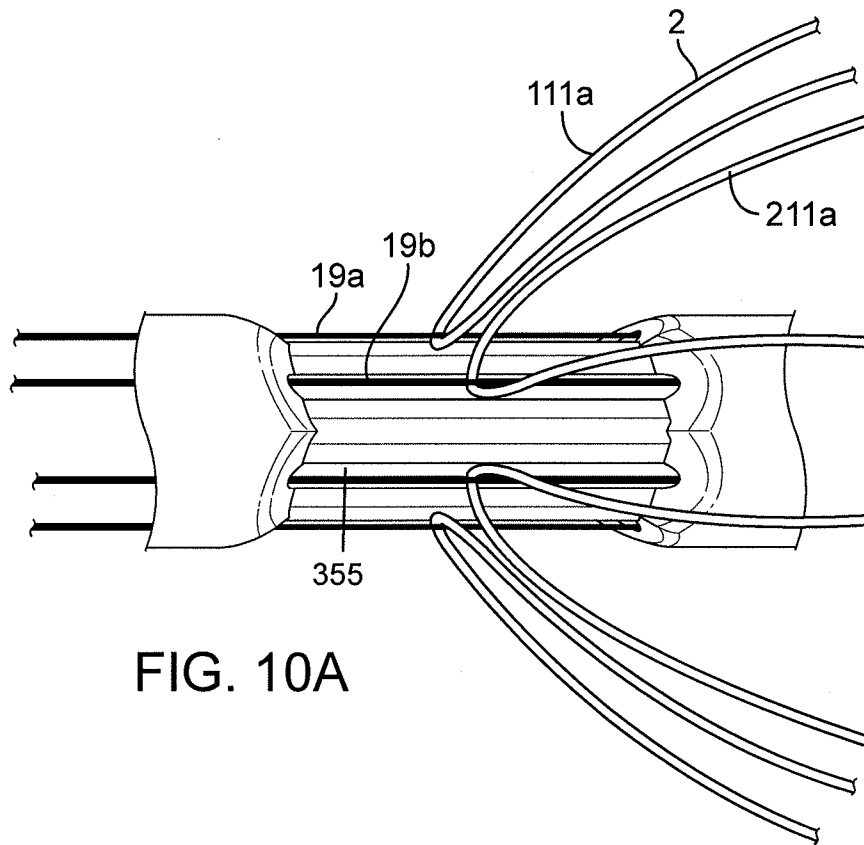

FIG. 10A

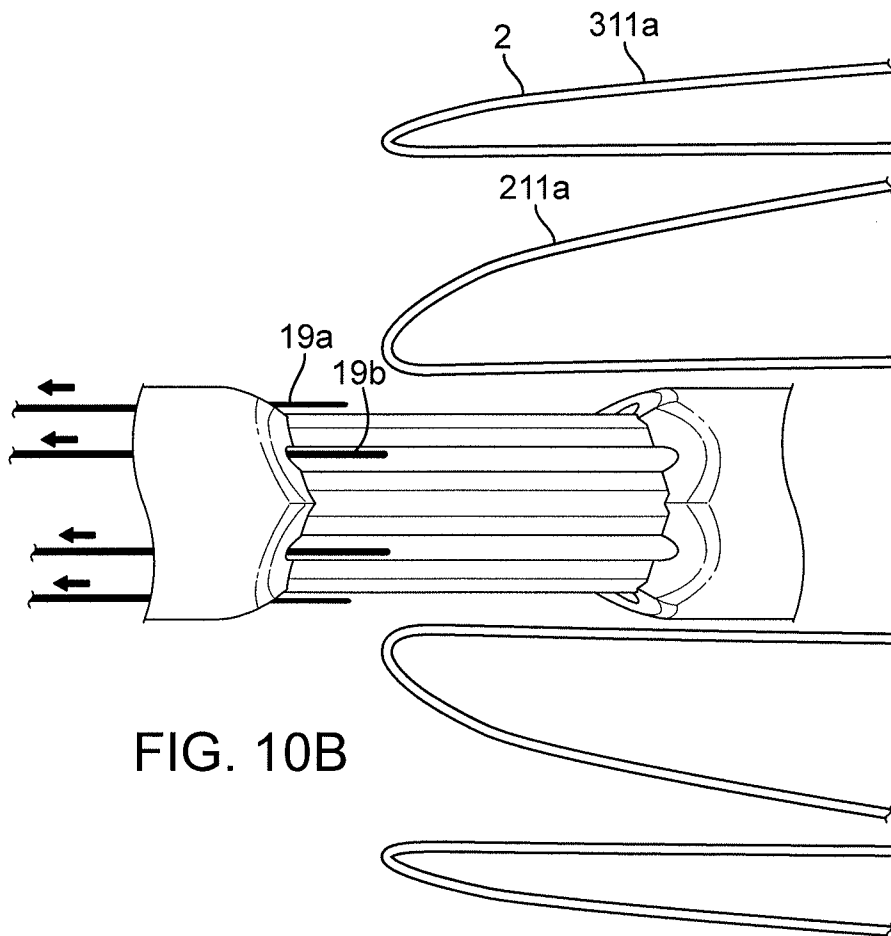

FIG. 10B

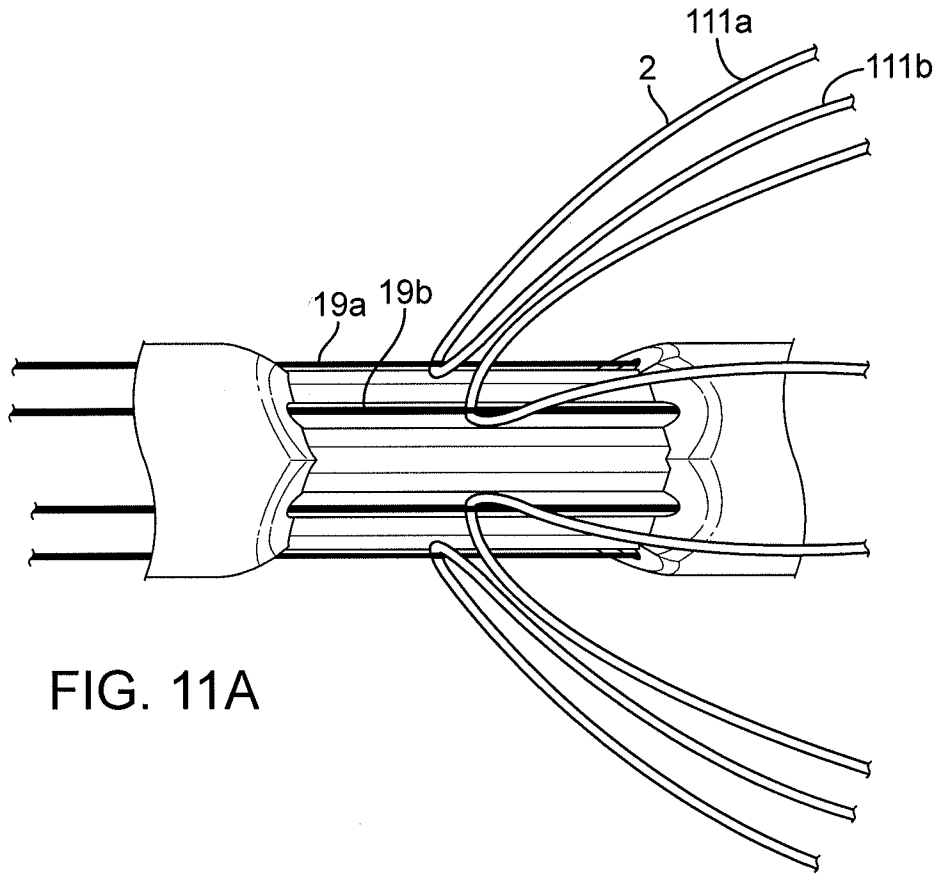

FIG. 11A

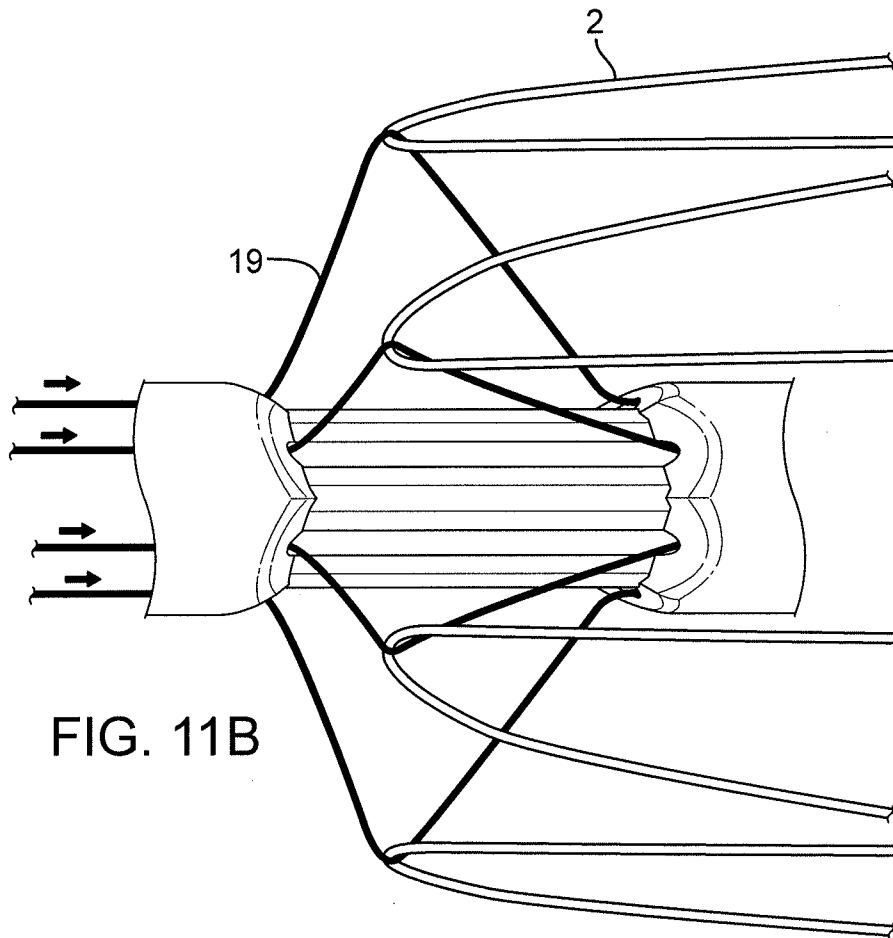

FIG. 11B

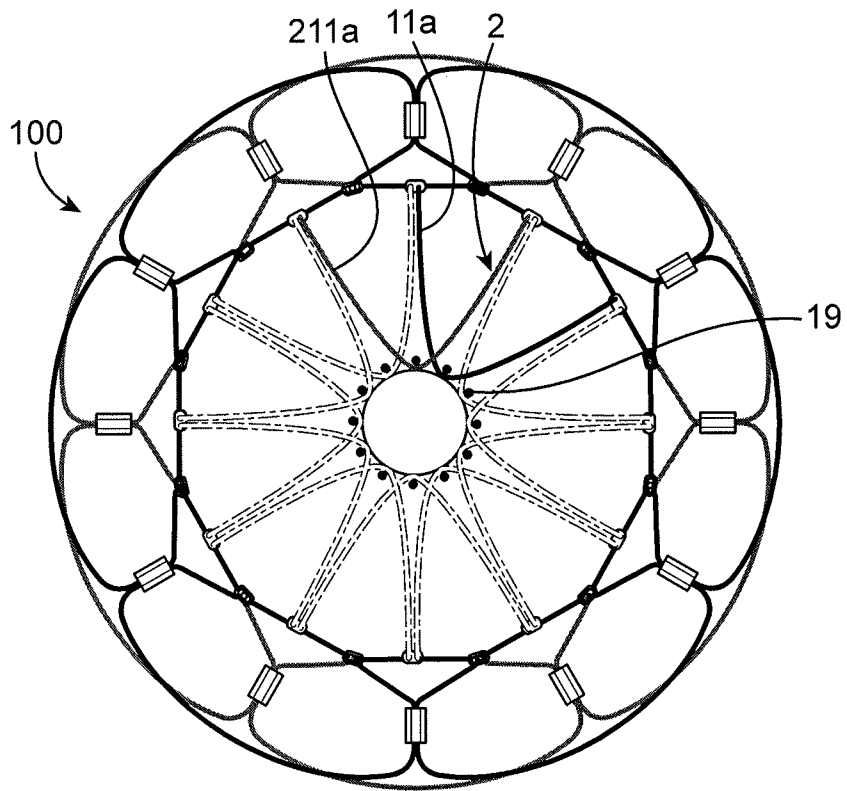

FIG. 12A

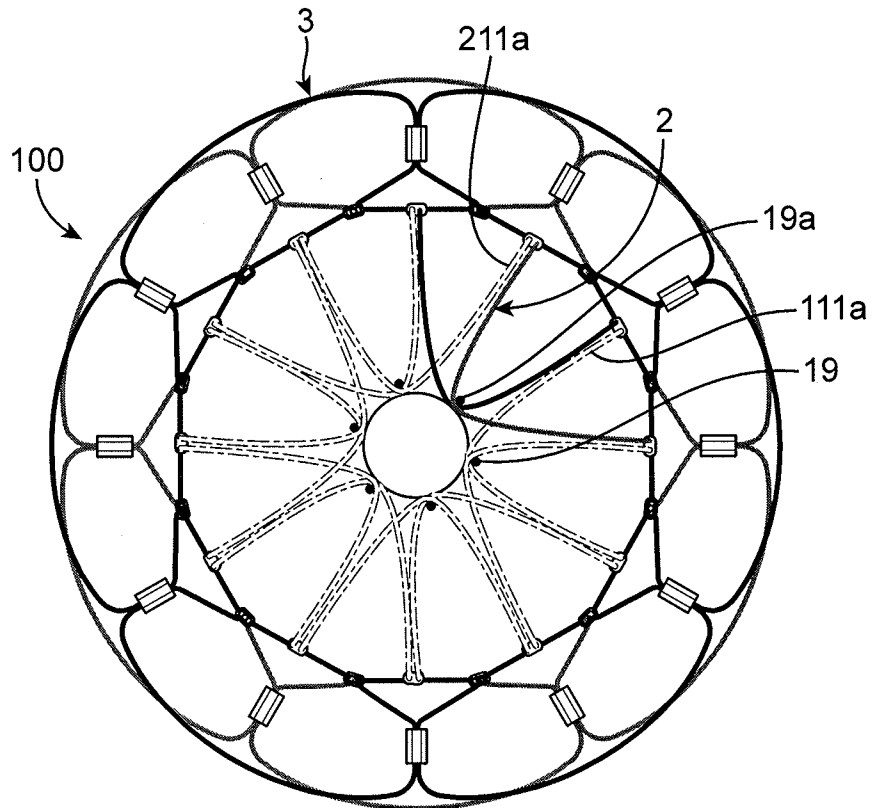

FIG. 12B

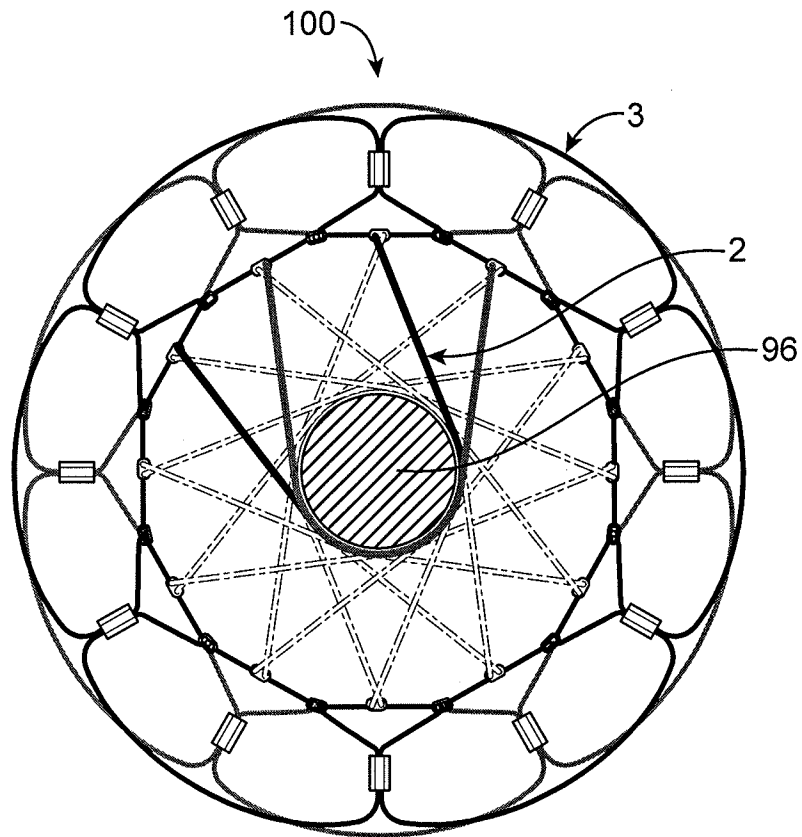

FIG. 13