

William E. Whitehead's
IMPROVEMENT in OPENERS, PICKERS, &c.

110318

PATENTED DEC 20 1870

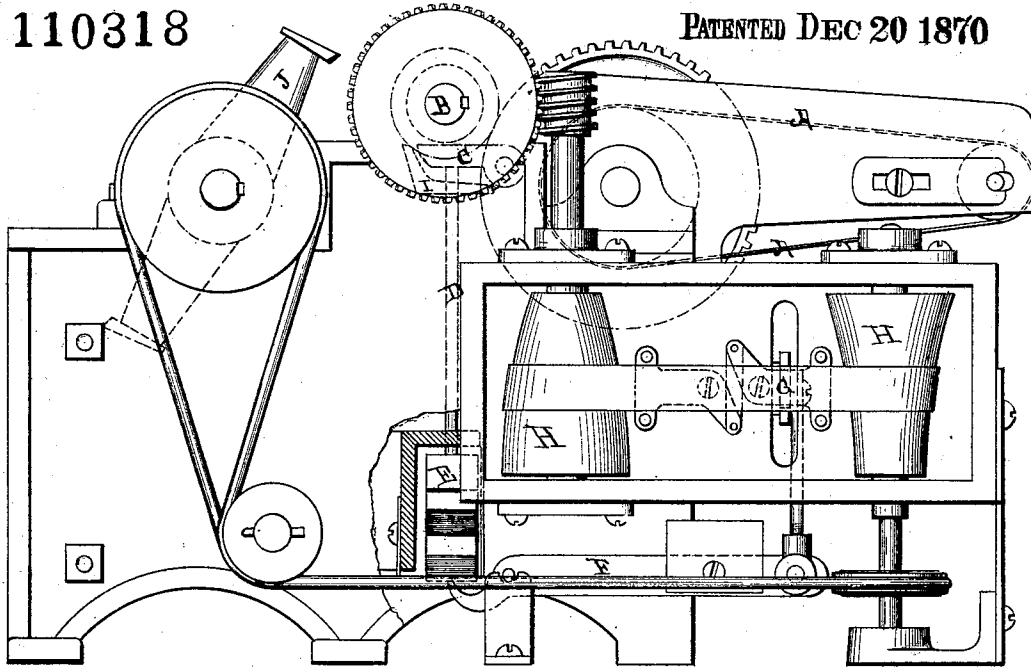

FIG. 1.

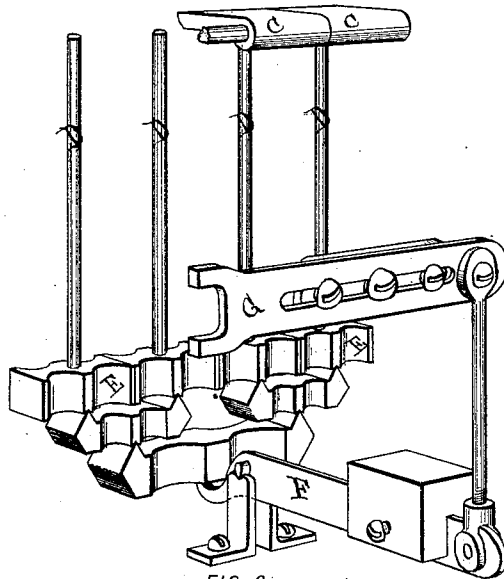

FIG. 2.

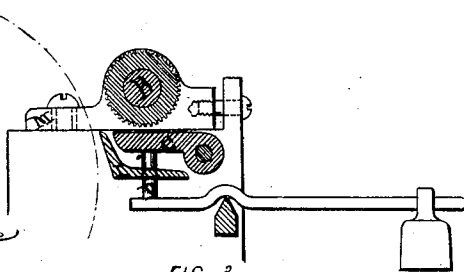

FIG. 3.

Witnesses,
Albert M. Moore
Levi Dumas

Inventor,
William E. Whitehead
by Abel J. Alherton his atty

William E. Whitehead's.

IMPROVEMENT in OPENERS, PICKERS, &c.

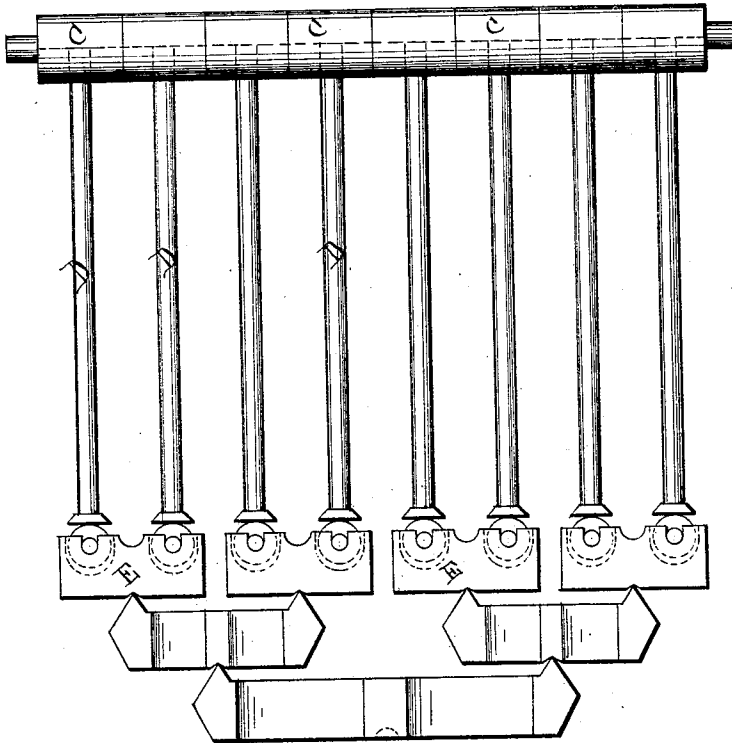

FIG. 4.

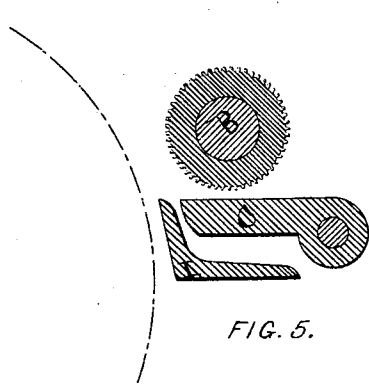

FIG. 5.

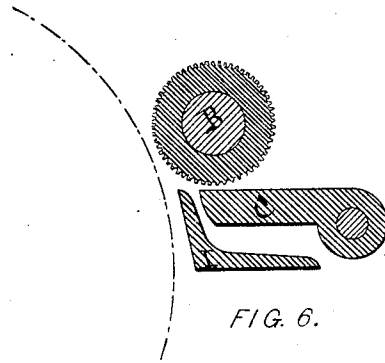

FIG. 6.

Witnesses.
Albert M. Moore
Levi Dumas

Inventor.
William E. Whitehead,
by *Abel T. Scherwin,*
his attorney.

UNITED STATES PATENT OFFICE.

WILLIAM EDWARD WHITEHEAD, OF MILES PLATTING, ENGLAND.

IMPROVEMENT IN FEEDING MECHANISMS FOR COTTON-OPENERS, &c.

Specification forming part of Letters Patent No. **110,318**, dated December 20, 1870.

I, WILLIAM EDWARD WHITEHEAD, of Miles Plating, county of Lancaster, England, have invented certain new and useful Improvements in Openers, Pickers, Scutchers, Carding-Engines, &c., of which the following is a specification:

My invention relates to the construction and arrangement of certain operating parts attached to the machine, by means of which cotton or other fibrous substances are more quickly and thoroughly cleaned and opened, and with less liability of injuring the staple, than by the use of the apparatus commonly employed, and also to be easily adjusted to work all lengths of staple with equal advantage.

Figure 1 is a side elevation of a picker with my improvements attached. Fig. 2 is a perspective view of the arrangement of levers for working belt-shippers, showing a series of plates, independent of each other, connected to independent beams. Fig. 3 represents the method of adjusting the feed-roller. Fig. 4 is a view of another arrangement of plates with beams, showing a series of plates connected in pairs with independent beams. Figs. 5 and 6 show the different positions of the feed-roller in working long or short staple of cotton, dotted lines representing the track of the beater-blades.

The same letters, wherever they appear, refer to corresponding parts of the machine.

A is the apron. B is the feed-roller. C C are two of a number of plates, said plates being flat on their upper surface, and, when connected to the operating parts, regulate the supply of cotton to the beater. D D D are perpendicular rods, connected at one end to the beams E E E, and pressing with the other end the plates C C C. E E E are beams connected to rods D D D. F is a weighted lever, by means of which the rods D D D press against the plates C C C. Said lever, by the operation of said plates, also communicates motion to the shipper-rod G, said shipper operating the belt on cone-pulleys H H, and regulating thereby the speed of the feed-roller. I is an independent shell-plate or bar, so placed as to be capable of relieving the plates C C from the action of the beater J, (said action of the beater, without said shell plate, interferes with the regulating arrangement of said plates,) and at

the same time, in connection with said beater, thoroughly removing all seed or dirt from the fibers.

The roller B and plates C C can be used without the shell-plate I, if required.

J is a beater of a form commonly in use.

In Fig. 3 the roller B is arranged on an adjustable stand, M, so that, in connection with plates C C and shell-plate I, said roller can be regulated to work any length of fiber without damaging the staple.

The cotton to be cleaned and opened is first placed upon the apron, and, by the operation of the machine, is carried between the feed-roller and plates C C and acted upon by the beater.

By the use of the plates commonly employed, (where, instead of a number of plates, as in my invention, but one is used,) great care is necessary in feeding the cotton into the machine, so that there shall be a sheet of even thickness continually passing between said feed-roller and plate. This is necessary to guard against the danger of injuring the staple, and to prevent the escape of portions of the cotton from the machine in an uncleaned condition, as is the case if a sheet of cotton thicker on one or both edges than in the center passes between said feed-roller and plate, as commonly constructed, for in the latter case the thick portions of the sheet would operate on the plate and cause a sufficient distance to intervene between the feed-roller and plate, thus preventing the action of the feed-roller upon the thinner portions of the said sheets, and allowing them to be drawn from the apron faster than is beneficial to the staple or the working of the cotton.

Owing to the construction of my plates, but a slight amount of care is necessary in feeding in the cotton, as, in case sheets of cotton of an uneven thickness pass between the feed-roller and plates, each plate, by the operation of the beams, maintains a uniform pressure on such portion of the sheet as it comes in contact with, and prevents any portion of the cotton from being drawn through the space between said feed-roller and plates faster than is beneficial.

By the combination of the beams E E, lever F, plates C C, and shipper-rod G, an equaliz-

ing arrangement of the most sensitive nature is produced, and put into operation by the slightest unevenness of the sheet of cotton passing between the feed-roller and plates, and perfectly regulates the speed of the feed-roller to accommodate the quantity of the cotton so passing.

By the introduction of the shell-plate I, the jarring effect commonly noticed upon the plates C C, and which disturbs the uniformity of the pressure during the passage of the cotton over said plates, is avoided, as said shell-plate receives the force of the concussion consequent upon the beater striking the cotton in close proximity to and as it passes over said shell-plate; also, by the introduction of the arrangement for adjusting the feed-roller, as shown in Fig. 3, a short or long staple of cotton can be used with equal advantage, the position of said

roller when a long staple is used being shown at Fig. 5, and when a short staple is used being shown at Fig. 6.

I claim as my invention—

1. The combination of the rods D, beams E, plates C, and shell-plate I with the feed-roller B, and the weighting and shifting devices F G, all constructed and arranged substantially as described, and for the purpose specified.

2. The combination of the plates C, rods D, and beams E with the weighting and shifting devices F G, all constructed and arranged substantially as described, and for the purpose specified.

WILLIAM EDWARD WHITEHEAD.

Witnesses:

ALBERT M. MOORE,
ABEL T. ATHERTON.