

AUSTRALIA
PATENTS ACT 1952

A

APPLICATION
BY INVENTOR

DECLARATION IN SUPPORT OF AN APPLICATION NO. 64732/86
FOR A PATENT

In support of an application made for a patent for an invention entitled:

TITLE "ISOLATION CABINET"

FULL NAME AND
ADDRESS OF
SIGNATORY

I, PETER B. GRAHAM
of 105 SANDY POINT ROAD,
SOMERS, VICTORIA 3927, AUSTRALIA,

do solemnly and sincerely declare as follows:

1. I am the applicant for the patent.
2. I am the actual inventor of the invention.
- ~~3. The basic application as defined by Section 141 of the Act was made in my name~~

COUNTRY

in

DATE

on

DELETE PARAGRAPHS
3 AND 4 FOR
NON-CONVENTION
APPLICATION

- ~~4. The basic application referred to in the preceding paragraph was the first application made in a Convention country for protection in respect of the invention the subject of this application.~~

PLACE AND DATE
OF SIGNING

Declared at

HASTINGS

this

18th

day at

JUNE

19 90

Signed

PETER B. GRAHAM

GRIFFITH HACK & CO

PATENT AND TRADE MARK ATTORNEYS

MELBOURNE · SYDNEY · PERTH

Ref: AJFW:E:P4030

(12) PATENT ABRIDGMENT (11) Document No. AU-B-64732/86
(19) AUSTRALIAN PATENT OFFICE (10) Acceptance No. 601162

(54) Title
ISOLATION CABINET

International Patent Classification(s)
(51)⁴ B01L 001/00 A01K 001/00 A01K 031/18 A01K 031/19
A61G 011/00

(21) Application No. : 64732/86 (22) Application Date : 29.09.86

(87) WIPO Number : WO87/01966

(30) Priority Data

(31) Number (32) Date (33) Country
PH2671 30.09.85 AU AUSTRALIA

(43) Publication Date : 24.04.87

(44) Publication Date of Accepted Application : 06.09.90

(71) Applicant(s)
PETER BEST GRAHAM

(72) Inventor(s)
PETER BEST GRAHAM

(74) Attorney or Agent
GRIFFITH HACK & CO., MELBOURNE

(57) Claim

1. An isolation cabinet to house small laboratory animals or chickens for extended periods of time comprising a cabinet body defining an interior chamber to receive the animals or chickens; an air inlet for admission of air into the chamber; an air outlet for outlet of air from the chamber to an exhaust extension to the cabinet; forced flow air flow means operable to force an air flow through the chamber via the air inlet and air outlet directly to the exhaust; an observation window in the cabinet body for viewing the interior of the chamber; and at least one glove port in the cabinet body for handling said creature in the chamber; and a transfer chamber formed by the cabinet body adjacent the interior chamber and fitted with sealable inner and outer door openings, respectively, to the interior chamber and to the exterior of the cabinet.

8. An isolation cabinet to house at least one living creature, comprising:

a rigid cabinet body defining an interior chamber to receive the living creature;

(11) AU-B-64732/86
(10) 601162

-2-

an air inlet for admission of air into the chamber;
an air outlet for outlet of air from the chamber to
an exhaust extension to the cabinet;

forced flow air flow means operable to force an air
flow through the chamber via the air inlet and air outlet
directly to the exhaust;

an observation window in the cabinet body for
viewing the interior of the chamber;

at least one glove port in the cabinet body for
handling said creature in the chamber;

a transfer chamber formed by the cabinet body
adjacent the interior chamber and fitted with sealable
inner and outer door openings, respectively, to the
interior chamber and to the exterior of the cabinet;

a sump formed by the cabinet body in the bottom of
the interior chamber;

a perforated floor in the bottom of the interior
chamber;

film holder means to hold film material such that
it extends across the bottom of the interior chamber
beneath the perforated floor to catch excreta of the living
creature and to enable the film to be drawn into the sump;
and

a sump pass-out port to enable film and excreta to
be withdrawn from the sump without disrupting the isolation
of the interior chamber.

9. An isolation cabinet installation comprising:

a base structure;

a swinging cabinet support mounted on the base
structure for swinging movement about a generally
horizontal axis;

at least two isolation cabinets pivotally mounted
on the swinging cabinet support for pivoting movement
relative to the cabinet support, said isolation cabinet
comprising:

a rigid cabinet body defining an interior chamber
to receive the living creature;

an air inlet for admission of air into the chamber;

an air outlet for outlet of air from the chamber to

(11) AU-B-64732/86
(10) 601162

-3-

an exhaust extension to the cabinet;

forced flow air means operable to force an air flow through the chamber via the air inlet and air outlet directly to the exhaust;

an observation window in the cabinet body for viewing the interior of the chamber;

at least one glove port in the cabinet body for handling said creature in the chamber; and

a transfer chamber formed by the cabinet body adjacent the interior chamber fitted with sealable inner and outer door openings, respectively, to the interior chamber and to the exterior of the cabinet;

a sump formed by the cabinet body in the bottom of the interior chamber;

a perforated floor in the bottom of the interior chamber;

film holder means to hold film material such that it extends across the bottom of the interior chamber beneath the perforated floor to catch excreta of the living creature and to enable the film to be drawn into the sump; and

a sump pass-out port to enable film and excreta to be withdrawn from the sump without disrupting the isolation of the interior chamber.

PCT

AU-AI 64732/86
WORLD INTELLECTUAL PROPERTY ORGANIZATION
International Bureau



601162

INTERNATIONAL APPLICATION PUBLISHED UNDER THE PATENT COOPERATION TREATY (PCT)

<p>(51) International Patent Classification 4 : B01L 1/00, A01K 1/00 A61G 11/00 // A01K 31/18 A01K 31/19</p>	<p>A1</p>	<p>(11) International Publication Number: WO 87/ 01966 (43) International Publication Date: 9 April 1987 (09.04.87)</p>
<p>(21) International Application Number: PCT/AU86/00281 (22) International Filing Date: 29 September 1986 (29.09.86) (31) Priority Application Number: PH 2671 (32) Priority Date: 30 September 1985 (30.09.85) (33) Priority Country: AU (71)(72) Applicant and Inventor: GRAHAM, Peter, Best [AU/AU]; 105 Sandy Point Road, Somers, VIC 3927 (AU). (74) Agent: CLEMENT HACK & CO.; 601 St. Kilda Road, Melbourne, VIC 3004 (AU). (81) Designated States: AT (European patent), AU, BE (European patent), CH (European patent), DE (European patent), FR (European patent), GB (European patent), IT (European patent), JP, LU (European patent), NL (European patent), SE (European patent), US.</p>	<p>Published With international search report.</p> <div data-bbox="858 571 1257 728" style="border: 1px solid black; padding: 5px; margin: 10px 0;"> <p>amc...</p> </div> <p style="text-align: center; font-weight: bold;">A.O.J.P. 28 MAY 1987</p> <div data-bbox="944 918 1248 1093" style="border: 1px solid black; padding: 10px; margin: 10px 0; text-align: center;"> <p>AUSTRALIAN 24 APR 1987 PATENT OFFICE</p> </div>	

(54) Title: ISOLATION CABINET

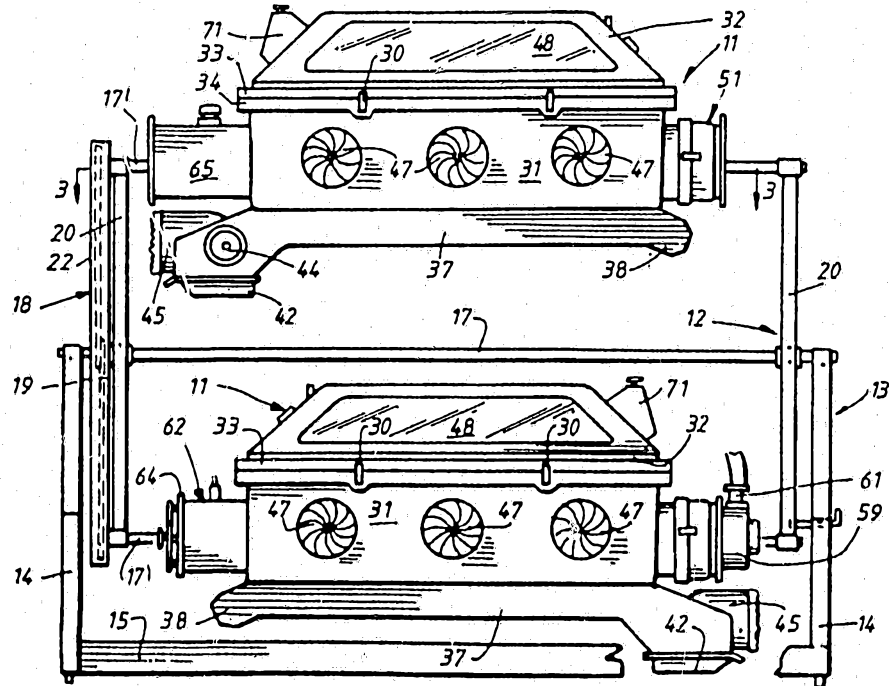

(57) Abstract

Isolation cabinet (11) for living creatures, particularly chickens. Fan (53, 59) provides forced airflow through interior chamber of the cabinet via inlet (51) and outlet (55) fitted with air purification filters (52, 57). Fan may be operated to maintain either a positive pressure within the chamber or a negative pressure compared with atmospheric pressure. A pair of cabinets are carried on a swinging support (12) such that they can be supported one above the other and such that by movement of the swinging support their positions can be interchanged.

- 1 -

ISOLATION CABINET

5 Technical Field

This invention relates to isolation cabinets for housing living creatures in an environment having a high degree of micro-biological security.

The invention has arisen to satisfy a specific need
10 for isolation cabinets to house poultry from day old chicks to approximately ten weeks of age but it will be appreciated from the ensuing description that the same or similar cabinets could be used for housing other living creatures such as mice, rats and other laboratory animals which must be kept in
15 micro-biological isolation.

Summary of the Invention

5 According to the present invention there is provided an isolation cabinet to house small laboratory animals or chickens for extended periods of time comprising a cabinet body defining an interior chamber to receive the animals or chickens; an air inlet for admission of air into the chamber; an air outlet for outlet of air from the chamber to an exhaust extension to the cabinet; forced flow air flow means operable to force an air flow through the chamber via the air inlet and air outlet directly to the exhaust; an observation window in the cabinet body for viewing the interior of the chamber; and at least one glove port in the cabinet body for handling said creature in the chamber; and a transfer chamber formed by the cabinet body adjacent the interior chamber and fitted with sealable inner and outer door openings, respectively, to the interior chamber and to the exterior of the cabinet.

10
15
20 According to the present invention there is further provided an isolation cabinet to house at least one living creature, comprising:

- 25 a rigid cabinet body defining an interior chamber to receive the living creature;
- an air inlet for admission of air into the chamber;
- an air outlet for outlet of air from the chamber to an exhaust extension to the cabinet;
- forced flow air flow means operable to force an air flow through the chamber via the air inlet and air outlet directly to the exhaust;
- an observation window in the cabinet body for viewing the interior of the chamber;
- at least one glove port in the cabinet body for handling said creature in the chamber;
- a transfer chamber formed by the cabinet body adjacent the interior chamber and fitted with sealable inner and outer door openings, respectively, to the interior chamber and to the exterior of the cabinet;
- 35 a sump formed by the cabinet body in the bottom of the interior chamber;



a perforated floor in the bottom of the interior chamber;

film holder means to hold film material such that it extends across the bottom of the interior chamber
5 beneath the perforated floor to catch excreta of the living creature and to enable the film to be drawn into the sump; and

a sump pass-out port to enable film and excreta to be withdrawn from the sump without disrupting the isolation
10 of the interior chamber.

According to the present invention there is still further provided an isolation cabinet installation comprising:

a base structure;

15 a swinging cabinet support mounted on the base structure for swinging movement about a generally horizontal axis;

at least two isolation cabinets pivotally mounted on the swinging cabinet support for pivoting movement relative to the cabinet support, said isolation cabinet
20 comprising:

a rigid cabinet body defining an interior chamber to receive the living creature;

an air inlet for admission of air into the chamber;

25 an air outlet for outlet of air from the chamber to an exhaust extension to the cabinet;

forced flow air means operable to force an air flow through the chamber via the air inlet and air outlet directly to the exhaust;

30 an observation window in the cabinet body for viewing the interior of the chamber;

at least one glove port in the cabinet body for handling said creature in the chamber; and

a transfer chamber formed by the cabinet body
35 adjacent the interior chamber fitted with sealable inner and outer door openings, respectively, to the interior chamber and to the exterior of the cabinet;



a sump formed by the cabinet body in the bottom of the interior chamber;

a perforated floor in the bottom of the interior chamber;

5 film holder means to hold film material such that it extends across the bottom of the interior chamber beneath the perforated floor to catch excreta of the living creature and to enable the film to be drawn into the sump; and

10 a sump pass-out port to enable film and excreta to be withdrawn from the sump without disrupting the isolation of the interior chamber.

Brief Description of the Drawings

15 In order that the invention may be more fully explained, one particular embodiment will be described in some detail with reference to the accompanying drawings in which:

20 Figure 1 is a side elevation of a pair of isolation cabinets constructed in accordance with the invention and mounted on a pivoting support;

Figure 2 is an end elevation of the isolation cabinets shown in Figure 1;

Figure 3 is a cross-section on the line 3-3 in Figure 1;

25 Figure 4 is a cross-section on the line 4-4 in Figure 3; and

Figure 5 is a cross-section on the line 5-5 in Figure 3.

Best Mode of Carrying out the Invention

30 The drawings illustrate an isolation cabinet installation comprising a pair of isolation cabinets denoted generally as 11 which are carried on a swinging support frame

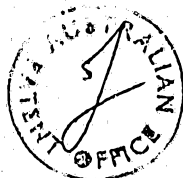

12 pivotally mounted on a main 'cradle frame 13. Cradle frame 13 comprises a pair of cradle ends 14 interconnected by a cranked lower bar 15. It is provided with wheels 16 so that the complete installation can be readily moved into a required 5 location.

A fixed axle 17 extends between the upper ends of the cradle ends 14 and carries the swinging frame 12. Frame 12 comprises two end arms 20 rotatable on the axle 17 and provided at their outer ends with stub axles 17' which carry 10 the isolation cabinets 11.

When the arms 20 of the swinging frame 12 are vertical, the isolation cabinets are held one above the other such that the upper cabinet is at a convenient height for inspection. Typically the upper part of the upper cabinet 15 will be at eye level for an average person. By swinging the swinging support frame 12 on its cradle mounting, the general positions of the two cabinets can be reversed so that the lower cabinet swings into the upper position and vice versa.

A sprocket and chain system denoted generally as 18 20 is provided to maintain the isolation cabinets at a constant attitude relative to the support frame, and therefore the ground, during such swinging movements. The sprocket and chain system 18 may comprise a chain 19 engaging a central sprocket 20 fixed to the central mounting axle 17 and an outer 25 pair of sprockets 21 fixed to two of the stub axles 17' of the isolation cabinets. A channel shaped guard 22 may be fitted around the chain and sprocket system.

Each isolation cabinet 11 comprises a main body portion 31 and a roof portion 32 moulded of a suitable 30 plastics material such as glass reinforced plastic, (GRP), polyvinyl chloride, polyethylene or polypropylene. These two body portions have opposing flanges 33, 34 and are clamped firmly together about a neoprene sealing gasket by means of over-centre clamps 30 operating on these flanges.

35 The cabinet body portions together define a hollow interior chamber 35 which is approximately 1 metre long, 0.6 metres wide and 0.65 metres high. A wire mesh floor 36 is

supported approximately 200 millimetres above the base 37 of the cabinet and this may be provided with a fine mesh overlay when very small chickens are to be housed in the cabinet.

The base part of the main body portion 31 is formed at one end with a compartment 38 which houses a roll 39 of polyethylene film. The film 41 from this roll is extended across the base of the chamber immediately beneath the mesh floor 36 to collect excreta and litter from the housed birds. When sufficiently soiled, the film is drawn into a drained sump 42 formed in a moulded compartment 43 moulded into the base of the cabinet body at its end remote from the compartment 38. This compartment is provided with a sealed pass-out port 44 to enable disposal of soiled film collected in the sump.

Access is gained to the under-floor area of the compartment via glove ports 45 adjacent to the pass-out port. A viewing window 46 is also provided at this end of the cabinet body.

Additional glove ports 47 are provided in either side of the main cabinet body portion for handling the birds and the roof portion 32 incorporates two viewing windows 48 to ensure an adequate view of the birds during such handling.

One end of the cabinet has an air inlet denoted generally as 51 comprising a filter compartment fitted with a high efficiency particulate air (HEPA) filter 52 to purify incoming air. An air inlet fan 53 is mounted in a removable plenum 54 attached to the filter chamber. The fan can be removed and replaced without compromising the environment in the cabinet.

The other end of the cabinet has an air outlet denoted generally as 55 which is generally similar to the air inlet in that it has a high efficiency air purification filter 56 mounted within an exhaust filter chamber 57 to which there is attached an exhaust plenum 58 housing an exhaust fan 59 and provided with an air outlet valve 61 for connection to an exhaust manifold.

In a typical installation the isolation cabinet will be installed within a room which is supplied with filtered air conditioned air. Inlet air is drawn from the conditioned room air through the air inlet and is filtered by the high efficiency inlet filter 52. Air flows from the cabinet through the exhaust filter 57 and is normally discharged to the atmosphere via an exhaust manifold extending outside the building. Separate inlet and outlet fans may be provided or a single fan may be interchangeable between the inlet and outlet. Air is forced through the inlet or drawn through the outlet so as to maintain within the cabinet a constant pressure which may be positive or negative relative to atmospheric pressure according to the requirements of the particular experimental program. In programs in which the cabinet houses poultry, roughing filters may be provided in advance of the exhaust filter to remove down and dust from air passing to the exhaust filter. Manometers or other devices are fitted to monitor internal pressure and pressure drops across the exhaust filter to indicate its condition.

The cabinet body is provided with a transfer chamber 62 adjacent to the outlet filter. This chamber is fitted with sealed inner and outer doors 63, 64 and can be purged to the air outlet via appropriate tubing. Access to the interior of the cabinet to remove birds or other material is obtained by opening the outer and inner doors after treatment of the enclosed space with paracetic acid or other disinfectant.

A water tank 65 is attached to the outer wall of the cabinet adjacent to the inlet filter compartment and feeds water to a drinking cup system 66 via tubing 67.

The roof moulding 32 is formed with a housing 68 for mounting an electrical control box and sealed glands are fitted to the cabinet body for the entry of cables and controls to an electric heater and circulation fan mounted internally. A fluorescent light 69 is provided internally for illumination and black out covers can be provided if necessary. A feed hopper 71 feeds grain to a feed trough 72 location within the cabinet.

Industrial Application

The illustrated cabinets enable chickens to be housed in a biologically isolated environment for long periods. They may be kept under positive or negative pressure compared with atmospheric pressure and they can readily be examined at all times. However the illustrated cabinets are advanced by way of example only and could be modified considerably. For example, the cabinet body could be modified so that one side wall (incorporated two glove ports) is removable. Two such cabinets could then be fitted together on removal of the side walls to produce a matching larger sized cabinet. It will be appreciated that details of the cabinet design could be varied considerably for applications in which rats, mice or larger animals are to be housed.

THE CLAIMS DEFINING THE INVENTION ARE AS FOLLOWS:

1. An isolation cabinet to house small laboratory animals or chickens for extended periods of time comprising a cabinet body defining an interior chamber to receive the animals or chickens; an air inlet for admission of air
5 into the chamber; an air outlet for outlet of air from the chamber to an exhaust extension to the cabinet; forced flow air flow means operable to force an air flow through the chamber via the air inlet and air outlet directly to the exhaust; an observation window in the cabinet body for
10 viewing the interior of the chamber; and at least one glove port in the cabinet body for handling said creature in the chamber; and a transfer chamber formed by the cabinet body adjacent the interior chamber and fitted with sealable inner and outer door openings, respectively, to
15 the interior chamber and to the exterior of the cabinet.

2. An isolation cabinet as claimed in Claim 1 further comprising a perforated floor in the bottom of the interior chamber, film holder means to hold film material such that it extends across the bottom of the interior chamber beneath the perforated floor to catch excreta of the living creature and to enable the film to be drawn into the sump, and a sump pass-out port to enable film and excreta to be withdrawn from the sump without disrupting the isolation of the interior chamber.

3. An isolation cabinet as claimed in either Claim 1 or Claim 2, wherein the forced airflow means comprises a fan operable to force air through the air inlet and through the chamber to maintain during said airflow a positive pressure within the chamber compared with atmospheric pressure.

4. An isolation cabinet as claimed in either Claim 1 or Claim 2, wherein the forced airflow means comprises a fan operable to draw air from the outlet to maintain within the cabinet during said airflow a positive pressure compared with atmospheric pressure.

64732/86



5. An isolation cabinet as claimed in either Claim 1 or Claim 2, wherein the forced airflow means comprises a fan which can be interchangeably fitted either to the inlet or to the outlet to permit operation such as to maintain during said airflow either a positive pressure within the chamber or a negative pressure compared with atmospheric pressure.

6. An isolation cabinet as claimed in either Claim 1 or Claim 2, wherein it is pivotally mounted together with another similar cabinet on a swinging cabinet support swingable about a generally horizontal axis and there is a cabinet attitude control means interconnecting the cabinet with the other cabinet and effective to maintain the attitude of each cabinet constant relative to the ground or swinging movement of the cabinet support.

7. An isolation cabinet as claimed in Claim 6, wherein the cabinet attitude control means comprises a first sprocket fixed to a base structure about the horizontal axis, two further sprockets coupled one to each cabinet and a chain interengaging all three sprockets.

8. An isolation cabinet to house at least one living creature, comprising:

a rigid cabinet body defining an interior chamber to receive the living creature;

an air inlet for admission of air into the chamber;

an air outlet for outlet of air from the chamber to an exhaust extension to the cabinet;

forced flow air flow means operable to force an air flow through the chamber via the air inlet and air outlet directly to the exhaust;

an observation window in the cabinet body for viewing the interior of the chamber;

at least one glove port in the cabinet body for handling said creature in the chamber;

64732/86



15 a transfer chamber formed by the cabinet body adjacent the interior chamber and fitted with sealable inner and outer door openings, respectively, to the interior chamber and to the exterior of the cabinet;

20 a sump formed by the cabinet body in the bottom of the interior chamber;

a perforated floor in the bottom of the interior chamber;

25 film holder means to hold film material such that it extends across the bottom of the interior chamber beneath the perforated floor to catch excreta of the living creature and to enable the film to be drawn into the sump; and

30 a sump pass-out port to enable film and excreta to be withdrawn from the sump without disrupting the isolation of the interior chamber.

9. An isolation cabinet installation comprising:

a base structure;

5 a swinging cabinet support mounted on the base structure for swinging movement about a generally horizontal axis;

at least two isolation cabinets pivotally mounted on the swinging cabinet support for pivoting movement relative to the cabinet support, said isolation cabinet comprising:

10 a rigid cabinet body defining an interior chamber to receive the living creature;

an air inlet for admission of air into the chamber;

an air outlet for outlet of air from the chamber to an exhaust extension to the cabinet;

15 forced flow air means operable to force an air flow through the chamber via the air inlet and air outlet directly to the exhaust;

64732/86



an observation window in the cabinet body for viewing the interior of the chamber;

20 at least one glove port in the cabinet body for handling said creature in the chamber; and

a transfer chamber formed by the cabinet body adjacent the interior chamber fitted with sealable inner and outer door openings, respectively, to the interior chamber and to the exterior of the cabinet;

25 a sump formed by the cabinet body in the bottom of the interior chamber;

a perforated floor in the bottom of the interior chamber;

30 film holder means to hold film material such that it extends across the bottom of the interior chamber beneath the perforated floor to catch excreta of the living creature and to enable the film to be drawn into the sump; and

35 a sump pass-out port to enable film and excreta to be withdrawn from the sump without disrupting the isolation of the interior chamber.

1.0. An isolation cabinet installation comprising:

a base structure;

5 a swinging cabinet support mounted on the base structure for swinging movement about a generally horizontal axis;

at least two isolation cabinets pivotally mounted on the swinging cabinet support for pivoting movement relative to the cabinet support, each said isolation comprising:

10 a rigid cabinet body defining an interior chamber to receive small laboratory animals or chickens for extended periods of time;

a sump in the bottom of the interior chamber;

15 a perforated floor in the bottom of the interior chamber to support the animals or chickens in the chamber and separating the sump from the interior chamber;



means within the sump to collect excreta from the animals or chickens falling through the perforated floor; an air inlet for admission of air into the chamber; an air outlet for outlet of air from the chamber to an exhaust extension to the cabinet;

20 forced flow air flow means operable to force an air flow through the chamber via the air inlet air outlet directly to the exhaust;

25 an observation window in the cabinet body for viewing the interior of the chamber;

at least one glove port in the cabinet body for handling said creature in the chamber;

30 a transfer chamber formed by the cabinet body adjacent the interior chamber and fitted with sealable inner and outer door openings, respectively, to the interior chamber and to the exterior of the cabinet; and

cabinet attitude control means interconnecting the cabinets and effective to maintain the attitude of each cabinet constant relative to the ground on swinging movement of the cabinet support, the swinging cabinet support being selectively moveable in between a position in which the cabinets are supported one above the other and an inverted position in which the positions of the cabinets are interchanged.

40 11. An isolation cabinet to house small laboratory animals or chickens for extended periods of time substantially as described herein with reference to and as illustrated in the accompanying drawings.

DATED this 15th day of June, 1990.

PETER BEST GRAHAM
By His Patent Attorneys

GRIFFITH HACK & CO.
Fellows Institute of Patent
Attorneys of Australia.

64732/86



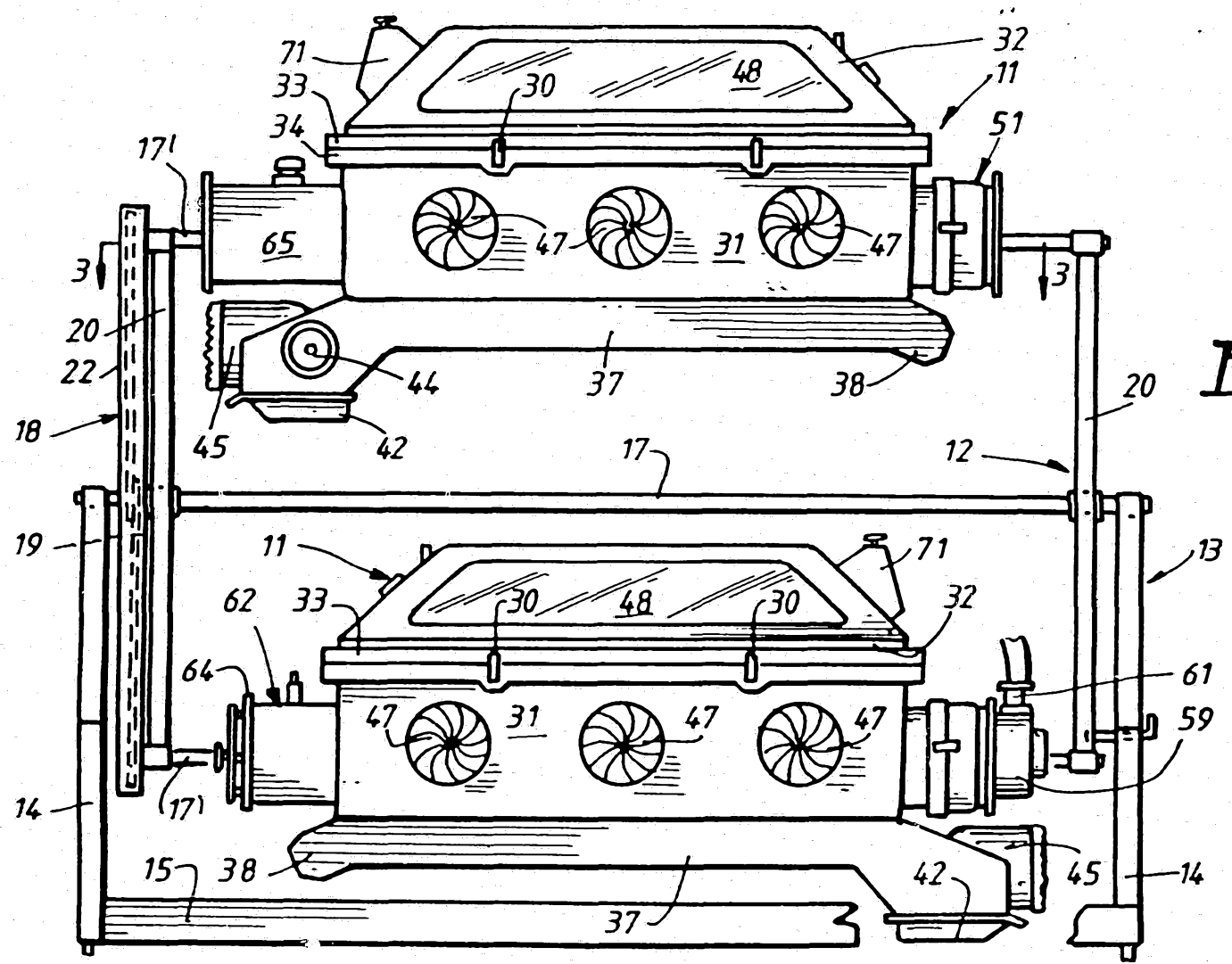
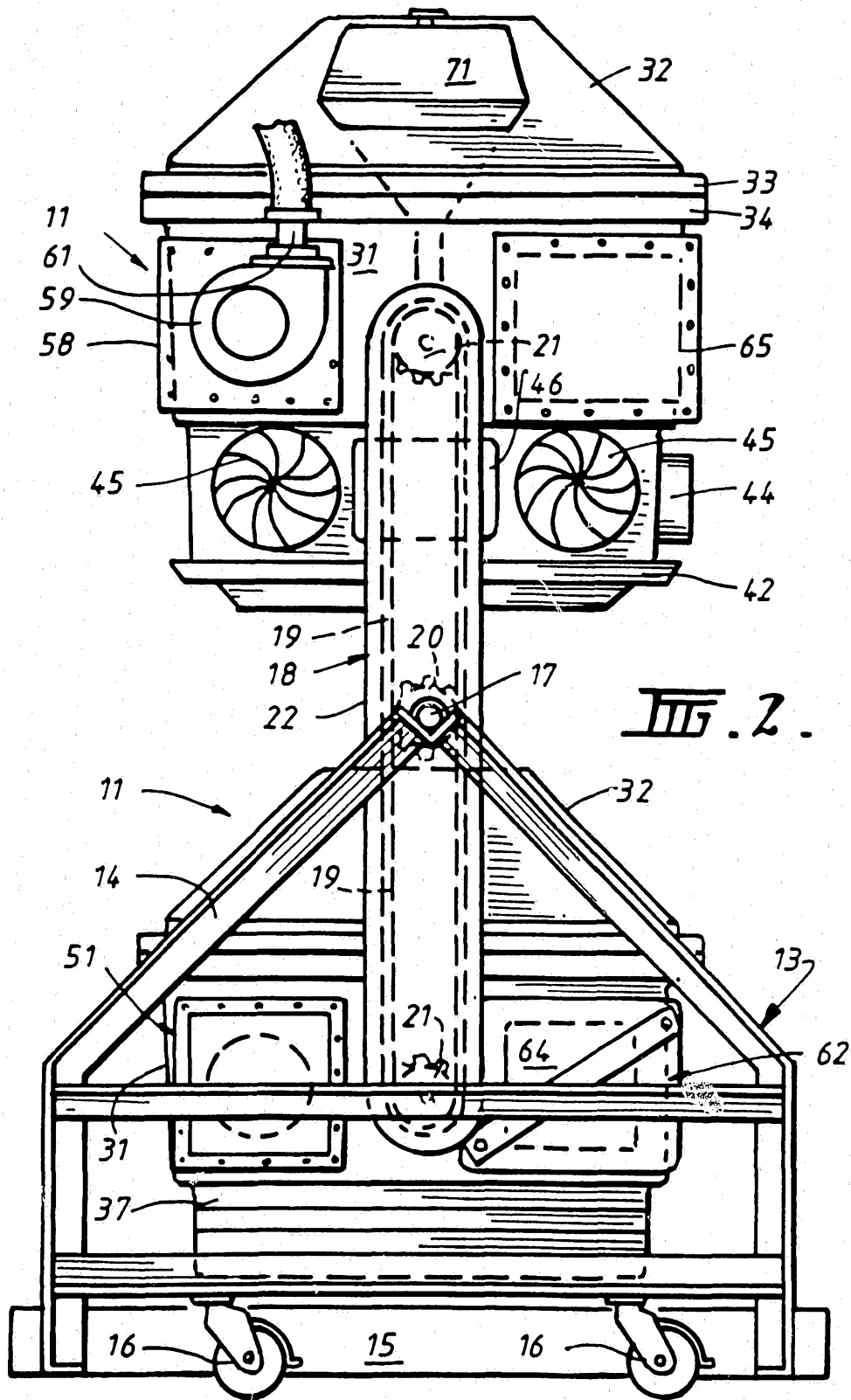
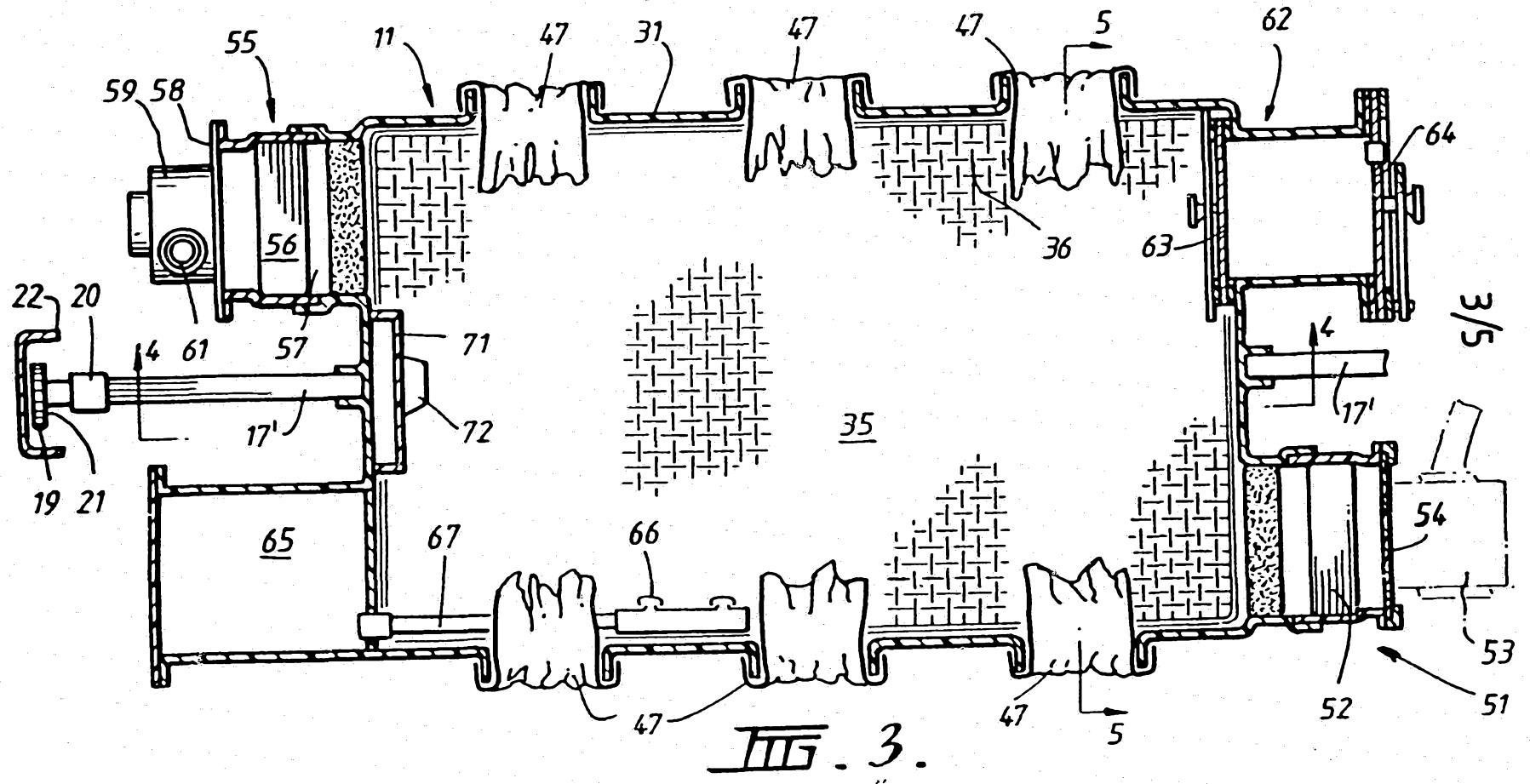

FIG. 1.

1/5

2/5





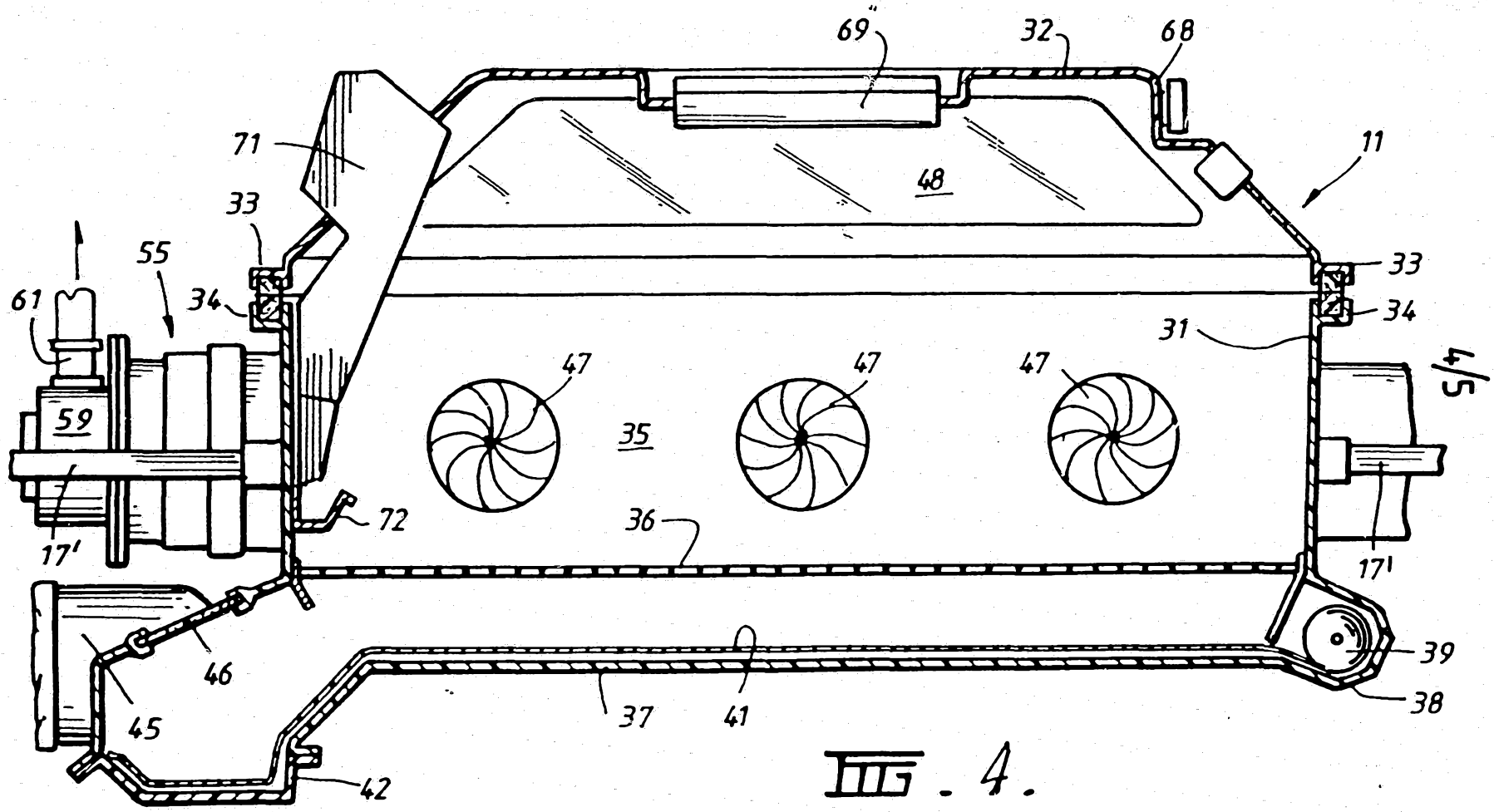

FIG. 4.

5/5

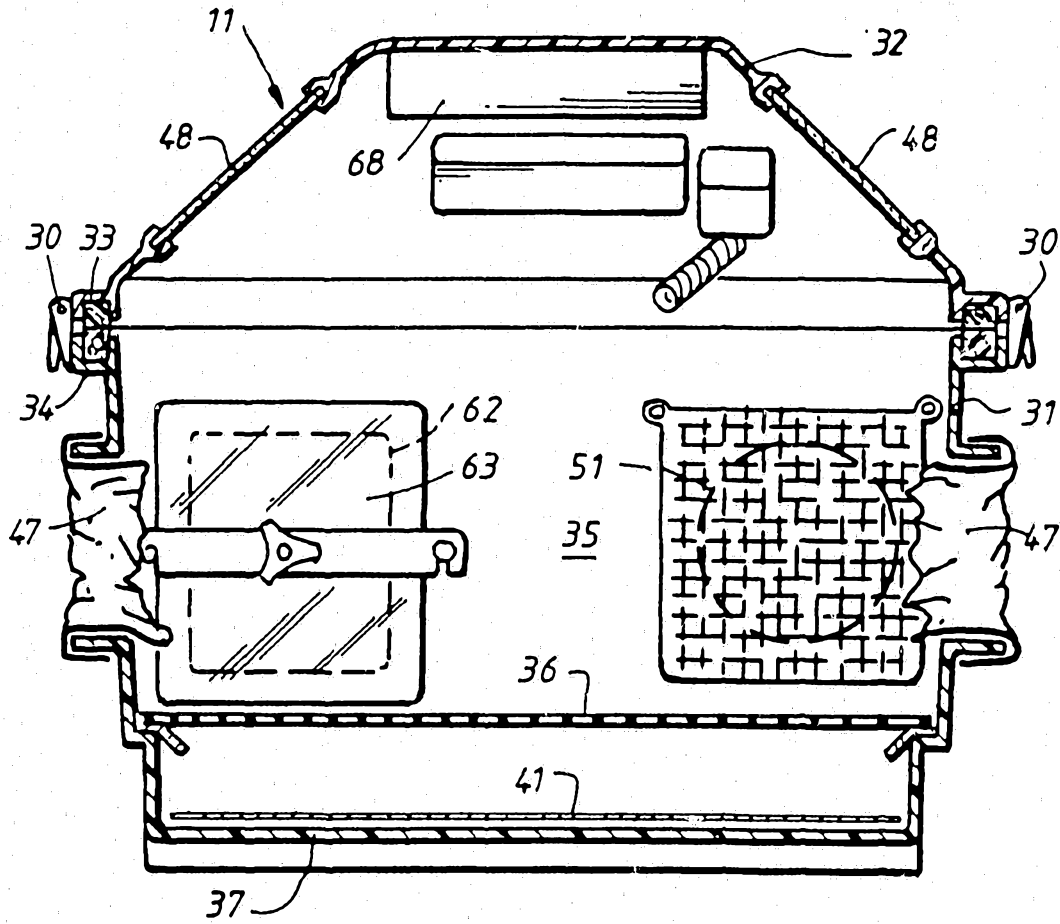

FIG. 5.

INTERNATIONAL SEARCH REPORT

International Application No PCT/AU 86/00281

I. CLASSIFICATION OF SUBJECT MATTER (Special classification symbols apply, indicate all) ⁶		
According to International Patent Classification (IPC) or to both National Classification and IPC		
Int. Cl. ⁴ B01L 1/00, A01K 1/00, A61G 11/00 / A01K 31/18, 31/19		
II. FIELDS SEARCHED		
Minimum Documentation Searched ⁷		
Classification System	Classification Symbols	
IPC	B01L 1/00, A01K 31/18, 31/19	
Documentation Searched other than Minimum Documentation to the Extent that such Documents are Included in the Fields Searched ⁸		
AU: IPC as above; A01K 1/00, 41/00, 41/04, A61M 16/02, A61G 10/00, 10/02, 10/04, E04H 5/08		
III. DOCUMENTS CONSIDERED TO BE RELEVANT⁹		
Category ¹⁰	Citation of Document ¹¹ with indication, where appropriate, of the relevant passages ¹²	Relevant to Claim No. ¹³
A	AU,B, 11913/33 (HARRISON) 29 March 1934 (29.03.34)	(1,2,13)
X	AU,B, 1640/51 (150326) (HIGGS) 31 May 1951 (31.05.51)	(1)
X	AU,B, 11260/55 (205358) (HAMNETT) 9 February 1956 (09.02.56)	(1,2)
X	AU,B, 53972/59 (236039) (AIR-SHIELDS INC.) 28 April 1960 (28.04.60)	(1,2,7)
X	AU,A, 21746/70 (INTERNATIONAL FARM SYSTEMS, INC.) 4 May 1972 (04.05.72)	(1,4,5,9)
Y	AU,B, 24640/77 (505087) (THE COMMONWEALTH INDUSTRIAL GASES LIMITED) 2 November 1978 (02.11.78)	(1,5)
X	US,A, 1814979 (TAYLOR) 14 July 1931 (14.07.31)	(1,4)
X	US,A, 4085705 (GLAND et al) 25 April 1978 (25.04.78)	(1,9,10)
A	US,A, 4216741 (MOSS) 12 August 1980 (12.08.80)	
Y	US,A, 4249482 (HARR) 10 February 1981 (10.02.81)	(3)
<p>⁶ Special categories of cited documents: 10</p> <p>"A" document defining the general state of the art which is not considered to be of particular relevance</p> <p>"E" earlier document but published on or after the international filing date</p> <p>"L" document which may throw doubts on priority claim(s) or which is cited to establish the publication date of another citation or other special reason (as specified)</p> <p>"O" document referring to an oral disclosure, use, exhibition or other means</p> <p>"P" document published prior to the international filing date but later than the priority date claimed</p> <p>"T" later document published after the international filing date of priority date and not in conflict with the application but cited to understand the principle or theory underlying the invention</p> <p>"X" document of particular relevance; the claimed invention cannot be considered novel or cannot be considered to involve an inventive step</p> <p>"Y" document of particular relevance; the claimed invention cannot be considered to involve an inventive step when the document is combined with one or more other such documents, such combination being obvious to a person skilled in the art.</p> <p>"A" document member of the same patent family</p>		
IV. CERTIFICATION		
Date of the Actual Completion of the International Search	Date of Mailing of this International Search Report	
7 December 1986 (07.12.86)	(18-12-86) 18 DECEMBER 1986	
International Searching Authority	Signature of Authorized Officer	
Australian Patent Office	H.W. Ness for B.R. DASHWOOD	

ANNEX TO THE INTERNATIONAL SEARCH REPORT ON
INTERNATIONAL APPLICATION NO. PCT/AU 86/00281

This Annex lists the known "A" publication level patent family members relating to the patent documents cited in the above-mentioned international search report. The Australian Patent Office is in no way liable for these particulars which are merely given for the purpose of information.

Patent Document Cited in Search Report	Patent Family Members		
AU 21746/70	BE 759288 CH 520248 US 3633547	BR 7023965 GB 1338409 US 3802390	CA 936053 LU 62128 US 3846559
US 4085705	CA 1067767		
US 4216741	CA 1116456 FR 2450634	CH 643984 GB 2048043	DE 3007946 JP 55150826

END OF ANNEX