

669677

SPRUSON & FERGUSON

AUSTRALIA

PATENTS ACT 1990

PATENT REQUEST: STANDARD PATENT

I/We, the Applicant(s)/Nominated Person(s) specified below, request I/We be granted a patent for the invention disclosed in the accompanying standard complete specification.

[70,71] Applicant(s)/Nominated Person(s):

Vance Products Incorporated d/b/a Cook Urological Incorporated,
incorporated in Indiana, of 1100 West Morgan Street, Spencer, Indiana,
47460, UNITED STATES OF AMERICA

[54] Invention Title:

Surgical Cutting Instrument

[72] Inventor(s):

Edward D. Pingleton, Paul G. Thomson

[74] Address for service in Australia:

Spruson & Ferguson, Patent Attorneys
Level 33 St Martins Tower
31 Market Street
Sydney New South Wales Australia (Code SF)

[31] Appl'n No(s):

790,583

Details of Basic Application(s):

[33] Country:

US

[32] Application Date:

8 November 1991

DATED this FIFTH day of NOVEMBER 1992

Vance Products Incorporated d/b/a Cook Urological Incorporated

By:

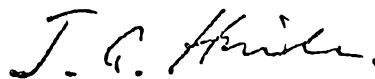

Registered Patent Attorney

033333 061192

IRN: 218762

INSTR CODE: 54781

Australia

Patents Act 1990

NOTICE OF ENTITLEMENT

I, John Gordon Hinde, of Spruson & Ferguson, St. Martins Tower, 31 Market Street, Sydney, New South Wales 2000, Australia, being the patent attorney for the Applicant/Nominated Person in respect of Application No 28206/92 state the following:-

The Applicant/Nominated Person has entitlement from the actual inventor(s) as follows:-

The Applicant/Nominated Person is the assignee of the actual inventor(s)

The Applicant/Nominated Person is entitled to rely on the basic application(s) listed on the Patent Request as follows:

The basic application listed on the Patent Request was not the first application made in a convention country in respect of the entire invention the subject of the present application. Application No. 543,679 made in the United States on 22 June 1990 by Edward D. Pingleton and Paul G. Thomson disclosed in part the invention the subject of the present application. Convention priority from the basic application is only claimed in respect of those forms of the invention first disclosed in the said basic application and not previously disclosed in the earlier Application No. 543,679

DATED this 19th day of January 1993

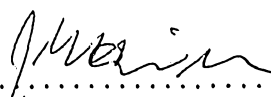
.....
John Gordon Hinde



AU9229206

(12) PATENT ABRIDGMENT (11) Document No. AU-B-28206/92
(19) AUSTRALIAN PATENT OFFICE (10) Acceptance No. 669677

- (54) Title
SURGICAL CUTTING INSTRUMENT
- International Patent Classification(s)
(51)⁵ **A61B 017/32 A61B 019/00**
- (21) Application No. : **28206/92** (22) Application Date : **06.11.92**
- (30) Priority Data
- (31) Number (32) Date (33) Country
790583 08.11.91 US UNITED STATES OF AMERICA
- (43) Publication Date : **13.6.93**
- (44) Publication Date of Accepted Application : **20.06.96**
- (71) Applicant(s)
VANCE PRODUCTS INCORPORATED D/B/A COOK UROLOGICAL INCORPORATED
- (72) Inventor(s)
EDWARD D. PINGLETON; PAUL G. THOMSON
- (74) Attorney or Agent
SPRUSON & FERGUSON , GPO Box 3898, SYDNEY NSW 2001
- (56) Prior Art Documents
US 4200106
US 4517977
US 5019036
- (57) Claim

1. A surgical cutting instrument comprising an elongated fixed outer sheath with a passageway therethrough, an elongated tubular cutter member rotatably mounted within the passageway of the sheath, a mechanism for rotatably driving the said member within the sheath, the distal end of the said member providing a peripheral circumferential cutter blade for cutting through tissue, and means for removing cut-through tissue via the said member, wherein the distal end of the sheath, when the device is in the cutting condition, is partially annularly closed to provide a distal end opening of smaller cross-sectional dimension than said passageway, and wherein the cutter blade of the said member is, during the said cutting condition, contained within the said passageway and with the cutter blade spaced inwardly from the said distal end opening.

AUSTRALIA
PATENTS ACT 1990

COMPLETE SPECIFICATION

FOR A STANDARD PATENT

ORIGINAL

Name and Address
of Applicant: Vance Products Incorporated d/b/a Cook Urological
Incorporated
1100 West Morgan Street
Spencer Indiana 47460
UNITED STATES OF AMERICA

Actual Inventor(s): Edward D. Pingleton, Paul G. Thomson

Address for Service: Spruson & Ferguson, Patent Attorneys
Level 33 St Martins Tower, 31 Market Street
Sydney, New South Wales, 2000, Australia

Invention Title: Surgical Cutting Instrument

The following statement is a full description of this invention, including the best method of performing it known to me/us:-

Surgical Cutting Instrument

This invention relates to percutaneous surgical cutting instruments and preferably to surgical instruments for debulking biological tissue.

Australian Patent Application No. 79263/91 in the prior art statement thereof,
5 describes surgical debulking instruments disclosed before June 22nd 1990.

A problem associated with side port or partially open-ended instruments, are the complex angles that are required for the cutting edges. Not only do these complex cutting angle instruments have limited access, but also provide limited control or directionality with respect to slicing or cutting soft tissue.

10 It is the object of the present invention to overcome or substantially ameliorate the above disadvantages.

There is disclosed herein a surgical cutting instrument comprising an elongated fixed outer sheath with a passageway therethrough, an elongated tubular cutter member rotatably mounted within the passageway of the sheath, a mechanism for rotatably driving
15 the said member within the sheath, the distal end of the said member providing a peripheral circumferential cutter blade for cutting through tissue, and means for removing cut-through tissue via the said member, wherein the distal end of the sheath, when the device is in the cutting condition, is partially annularly closed to provide a distal end opening of smaller cross-sectional dimension than said passageway, and wherein the
20 cutter blade of the said member is, during the said cutting condition, contained within the said passageway and with the cutter blade spaced inwardly from the said distal end opening.

The problem of inadvertently cutting tissue with an open-ended surgical instrument is solved and a technical advantage is achieved by a surgical cutting instrument of an
25 embodiment of the invention in which a cutting edge, that is positioned circumferentially about the distal end of an inner rotating member, is contained within the passageway of a stationary outer sheath. To further safeguard the cutting edge from inadvertent contact, the outer surface of the inner member and outer sheath annularly can close about the distal ends thereof. The contours of the annular closings of the sheath and the member
30 conform to one another, but they can be different if required. The member need not be annularly closed. The cutting action of the instrument is facilitated with a sideways motion when tissue is drawn through the distal ends of the outer sheath and inner member.

The distal ends of the elongated sheath and the inner member can each have a distal
35 opening therein. Typically, the hollow passageway of the elongated sheath has a first predetermined cross-sectional dimension, whereas the distal opening of the sheath can have a predetermined cross-sectional dimension smaller than that of the sheath



passageway. The distal opening of the inner member can be positioned within the elongated sheath and typically has a cross-sectional dimension preferably smaller than the cross-sectional dimension of the inner member passageway.

5 Positioned between the inner member and elongated sheath can be a bearing surface on which the inner member rotates freely within the passageway of the outer sheath. The bearing surface can comprise an electrolysed material such as chrome deposited on the outer surface of the inner member about the distal and proximal ends thereof. In another embodiment, the bearing surface comprises a tube of PTFE that extends between the distal and proximal ends of the inner member.

10 The cutting instrument can include suction means for drawing tissue through the first and second distal openings of the outer sheath and inner member.

The annularly closing outer surface of the elongated sheath and inner member positioned about the distal ends thereof can include a uniformly radiused curvature for facilitating easy rotation of the inner member within the outer sheath and also for
15 advantageously preventing inadvertent head-on cutting of tissue.

Brief Description of the Drawings

Figs. 1, 2 and 3 illustrate figures which have been fully described and claimed in Australian Patent Application No. 79263/91. For a description of these figures reference is made to Figs. 1 to 3 and the description thereof in the above application.

20 Fig. 4 depicts a partially sectioned side view of an embodiment of the present invention;

Fig. 5 depicts a partially sectioned side view of the distal end of the surgical cutting instrument of Fig. 4; and

25 Fig. 6 depicts a partially sectioned pictorial view of the distal end of the surgical cutting instrument of Fig. 4.

30 Depicted in Fig. 4 is a partially sectioned side view of an illustrative surgical cutting instrument 400 having a rotary, open-ended cutting edge 407 for percutaneously debulking and cutting tissue. The cutting edge is completely contained within passageway 412 of outer sheath 409, which annularly closes about distal end 410 thereof to prevent perforation of the surgical tissue bag. The cutting instrument comprises an inner elongated cutting member tube



401 rotatably positioned within outer elongated sheath tube 409. Tissue is drawn into hollow passageway 404 of inner cutting tube member 401 with a vacuum applied thereto and cut with a sideways or lateral motion of the distal end of the instrument, which is provided
5 by the attending physician. Rotary drive mechanism 416 includes, for example, electric motor 440, which is positioned about proximal end 403 of inner cutting member tube 401 for rotating the tube and cutting tissue drawn within. A suction or vacuum line 422 is connected to the handle of the instrument to draw tissue within hollow passageway 404
10 of the inner cutting member tube. Severed tissue is drawn through the inner cutting member tube and exits evacuation port 418 of the tube into tissue collection chamber 419, which is positioned in the handle 431 of the instrument. Conically shaped screen 423 positioned in the bottom of the tissue collection chamber over vacuum port 424 prevents
15 the severed tissue from exiting the chamber and blocking the vacuum line. Vacuum control means 417 includes stopcock 425 that is positioned between the vacuum port and vacuum line and controls the amount of suction or vacuum applied to the cutting instrument.

The rotary drive mechanism of the embodiment of FIGS.4,5 and 6,
20 can alternatively be replaced by another form of drive mechanism such as shown in the arrangements of FIGS.1, 2 or 3.

Similarly the handle and evacuation system of the embodiments of FIGS.4, 5 and 6 can be replaced by other forms of handle and
evacuation system such as shown in the arrangements of FIGS.1, 2 or 3.

25 Inner cutting member tube 401 includes distal end 402, proximal end 403, and hollow passageway 404 extending longitudinally therein. Surrounding the rotary inner cutting member tube is stationary outer elongated sheath tube 409 with proximal end 411 thereof connected to the handle of the instrument via coupler 426. Hollow passageway 412
30 extends longitudinally in the outer sheath between distal end 410 and proximal end 411.

Depicted in FIGS.5 and 6 are enlarged partially sectioned views of distal end 402 of inner cutting member tube 401 and distal end 410 of outer sheath 409 of the cutting instrument. To prevent perforation
35 of a surgical tissue bag of which the tissue is contained, the

distal end 410 including the outer surface 413 of the stationary outer sheath closes annularly thereabout, to provide distal opening 414.

The distal end 410 extends up to or beyond the distal end 402 of cutting member 401, and is partially closed about the end 402 except
5 for the opening 414. The annular closing of end 410 is shown in FIGS.5 and 6 as being partially dome shaped. It will be appreciated, however, that the end 410 can be partially annularly closed about the end 402 by annular closures of other shape, such as a frusto-conically shaped end.

10 It is preferable that the distal end 402 of cutting member 401 is partially annularly closed in a manner similar to that of end 410. The end 402 can, however, be of a different shape to that of end 410 if required, but it should be within the passageway of the sheath at the distal end 410, in the sense that end 406 can extend up to end 414
15 or inwardly spaced therefrom.

Tissue is drawn through distal opening 414 of the outer sheath for engagement with rotary cutting edge 407 that is circumferentially positioned about distal opening 406 of the rotary inner cutting member tube. The physician applies a sideways or circular motion to the
20 distal end of the instrument for rotary edge 407 to cut the tissue drawn through the distal openings of the outer sheath and inner member tube. To further prevent perforation of the surgical tissue bag and ease operation of the instrument therein, respective annularly closing surfaces 427 and 428 of outer sheath 409 and inner cutting member tube
25 401 are uniformly radiused. As a result, distal opening 414 of the outer sheath and distal opening 406 of the inner cutting member tube each have a cross-sectional diameter dimension smaller than the cross-sectional diameter dimension of respective hollow passageways 412 and 404. In addition, circular distal opening 406 of the inner
30 tube is positioned within distal opening 414 of the outer sheath and has a smaller cross-sectional diameter dimension to draw tissue into the inner cutting member tube and into contact with rotary cutting edge 407 to cut the tissue with a sideways or circular motion provided by the attending physician. It is preferable that the rotary cutting
35 edge 407 has a diameter which is less than the diameter of opening



414 to facilitate cutting of the tissue. If required, however, the diameter of edge 407 can be equal to or less than the diameter of opening 414.

By way of example, outer elongated sheath tube 409 comprises a 300 series stainless steel tube approximately 12.38cms (4.875") in length with an outside diameter of 1.09cms (0.428") and inside diameter of 1.04cms (0.41"). The diameter of distal opening 414 of the outer sheath is approximately 0.79cms (0.31") to 0.8cm (0.315") with outer annularly closing surface 427 having a uniform radius of approximately 0.254cms (0.1"). Inner cutting member tube 401 comprises a 19cms (7.5") length of 300 series stainless steel tube having an outside diameter dimension of approximately 0.96cm (0.377") with a wall thickness of 0.0254cm (0.01") resulting in an inside diameter of approximately 0.9cm (0.357"). The diameter of circular distal opening 406 is approximately 0.698cm (0.275") with outer annularly closing surface 428 having a uniform radius of approximately 0.254cm (0.1"). Rotary cutting edge 407 has an included angle of approximately 25 to 30 degrees and faces inwardly in a perpendicular radial direction toward the longitudinal axis of the cutting tube. This particular orientation provides for a sideways cutting or sculpting action when tissue is drawn with suction through distal opening 406 and 414. As partially depicted in FIG.4, approximately 0.95cm (0.375") from proximal end 403 of the inner cutting member tube, evacuation port 418 extends for approximately 2.86cms (1.125") with a depth of 0.45cm (0.177") from outer surface 405 into hollow passageway 404. Nylon coupler 408 is fixedly positioned in hollow passageway 404 and extends from proximal end 403 of the inner cutting member tube for detachable engagement with shaft 441 of electric motor 440.

As depicted in FIGS.4 and 5, positioned about distal end 402 on outer surface 405 of the inner member is distal bearing surface 415 approximately 0.5cm in length and 0.5cm from distal end 402. This bearing surface is approximately 0.038cm (0.015") in thickness and comprises an electrolysed material such as 95% hard chrome for rotating inner member 401 within the passageway of the outer sheath.

A proximal bearing surface 420 is similarly positioned on the outer surface of the inner member about the proximal end of the outer sheath. The distance between the distal ends of the rotary inner cutting member tube and the stationary outer sheath is maintained with
5 thrust disc 429, which is positioned around inner member tube 401 proximal to the outer sheath and engages distal handle coupler 426 and PTFE bearing disc 430. Alternatively as shown in FIG.6, a thin-wall tube 421 of approximately 0.038cm (0.015") PTFE material is inserted between the inner member and outer sheath, which acts as the bearing
10 surface.

Hollow passageway 404 of rotary inner cutting member tube 401 extends the entire length of the tube for drawing and removing tissue severed from the surgical site through tissue evacuation port 418 and into tissue collection chamber 419. Handle 431 of the instrument
15 comprises a cylindrical T-shaped member with coupler 426 fixedly positioned in distal cross-bar opening 432. Rotary inner cutting member tube 401 is inserted through proximal cross-bar opening 433 of handle 431 and into outer sheath 409. A circular solid material disc 434 is positioned about the proximal end of the cutting tube to
20 prevent tissue from being drawn into electric motor 440. The disc is fixedly positioned in passageway 435 of the handle about proximal cross-bar opening 433 between inwardly extending flange 436 and the distal end of the rotary drive mechanism.

Tissue collection chamber 419 of the cutting instrument handle
25 includes hollow T-shaped passageway 435 which communicates with inner passageway 404 of the rotary inner cutting member tube via evacuation port 418. The tissue collection chamber is enclosed by cylindrical wall 437 of the T-shaped handle. The proximal end of the chamber includes removable cap 438 with chamber evacuation port 424 positioned
30 therein and vacuum stopcock 425 extending therefrom. As previously discussed, conically-shaped screen 423 prevents tissue from being drawn through evacuation port 424 and into vacuum or suction line 422. Suction means 417 of the cutting instrument comprises evacuation port 424, stopcock 425, and conically-shaped screen 423. The cylindrical
35 T-shaped handle of the instrument is comprised of any well-known

plastic material such as PVC which is easily moulded and shaped. Rotary drive mechanism 416 comprises a commercially available electrical motor 440 that is encased, for example, in plastic material cylinder case 439, which is readily screwed into proximal cross-bar opening 433 of the handle to engage rotary inner cutting member tube coupler 408.

With rotary drive mechanism 416 rotating inner cutting member tube 401, tissue is severed with cutting edge 407 and drawn through hollow passageway 404 and into tissue collection chamber 419 via evacuation port 418. A power and control line (not shown) is connected to the rotary drive mechanism to energize and control the speed of the electric motor. The physician controls the speed, for example, with the use of a foot pedal (not shown) connected to the power and control line. The vacuum applied to the tissue collection chamber via the suction means draws the severed tissue from the inner cutting member tube and into the collection chamber of the surgical cutting instrument handle. The physician regulates the suction applied to the chamber via stopcock 425.

The distal end of the cutting instrument may be devised to include serrated teeth or a modified cutting edge for providing any number of different cutting or slicing actions. The rounded distal end of the outer shield may be devised to include a series of rounded wires to permit penetration through soft tissue to permit cutting and slicing by the inner cutting member tube. Such a wire cage arrangement would also prevent puncture of a surgical tissue bag should one be desired to be used by the physician.

30

35

The claims defining the invention are as follows:

1. A surgical cutting instrument comprising an elongated fixed outer sheath with a passageway therethrough, an elongated tubular cutter member rotatably mounted within the passageway of the sheath, a mechanism for rotatably driving the said member within
 5 the sheath, the distal end of the said member providing a peripheral circumferential cutter blade for cutting through tissue, and means for removing cut-through tissue via the said member, wherein the distal end of the sheath, when the device is in the cutting condition, is partially annularly closed to provide a distal end opening of smaller cross-sectional dimension than said passageway, and wherein the cutter blade of the said member is,
 10 during the said cutting condition, contained within the said passageway and with the cutter blade spaced inwardly from the said distal end opening.

2. An instrument according to claim 1, wherein the cutter blade is serrated or continuous.

3. An instrument according to claim 1 or 2, wherein the inward curving of the
 15 outer sheath is in a smooth continuous manner of uniformly radiused curvature, and wherein the distal end of the tubular member is inwardly curved in a continuous manner also of uniformly radiused curvature.

4. An instrument according to claim 3, wherein the distal blade of the tubular cutter is of smaller dimension than the dimension of said distal end opening.

20 5. An instrument according to any one preceding claim, wherein bearing surface means are provided between the outer sheath and the said member to facilitate rotation of said member.

6. An instrument according to claim 5, wherein the bearing means are in the form of electrolysed surfaces formed on the said member.

25 7. An instrument according to any one preceding claim, wherein the said member has an evacuation port at a position along the member remote from the said distal end thereof, and wherein the port is in communication with the said means for removing, the latter comprising a suction arrangement.

8. An instrument according to claim 7, further comprising a tissue collection
 30 chamber connected between the evacuation port and the suction arrangement, the chamber being contained within the handle of the instrument.

9. An instrument according to claim 7, further comprising a shaped screen within the collection chamber to prevent tissue within the said chamber from reaching the suction arrangement.



10. A surgical cutting instrument substantially as hereinbefore described with reference to Figs. 4, 5 and 6 of the accompanying drawings.

Dated 29 April, 1996

Vance Products Incorporated d/b/a Cook Urological Incorporated

5

**Patent Attorneys for the Applicant/Nominated Person
SPRUSON & FERGUSON**

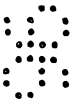

Surgical Cutting Instrument

Abstract

A surgical cutting instrument is disclosed in Fig. 4 for percutaneously debulking tissue through an access sheath. The cutting instrument includes an inner rotary member tube (401) having a cutting edge (407) at the distal end thereof for cutting and slicing tissue. The outside surface of the rotary inner cutting member tube and outer sheath (409) annularly close about the distal ends thereof for preventing perforation of the surgical tissue bag in which the tissue is contained. The inner cutting member tube includes a hollow passageway for suctioning and aspirating tissue and fluid through the tube and into a collection chamber (419) or out through a vacuum or suction line (422) attached thereto. Vacuum or suction control ports are included at the proximal end of the inner cutting member tube and stationary sheath for also controlling the amount of vacuum or suction applied to the tissue. The surgical cutting instrument includes a control handle (431) for grasping by the physician. A collection chamber is connected to a coupler connected to the stationary sheath for collecting tissue therein. The inner cutting member tube extends through the collection chamber to a drive motor (440) or to a remotely positioned rotary drive mechanism. A vacuum line is attached to the collection chamber for drawings tissue and fluid through the inner cutting member tube and into the collection chamber.

Figure 4

6 1 1 9 2 2 2 0 8

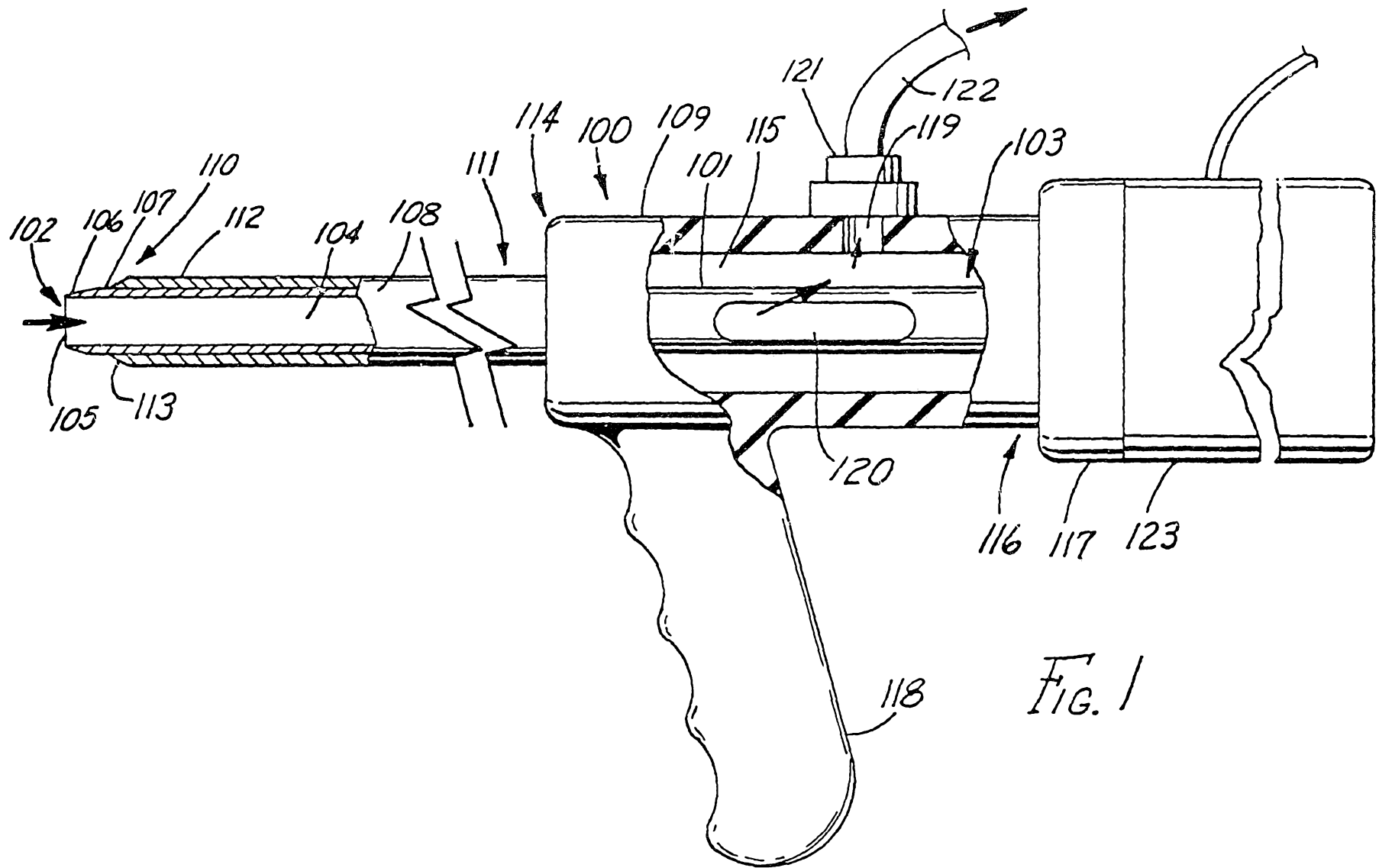

FIG. 1

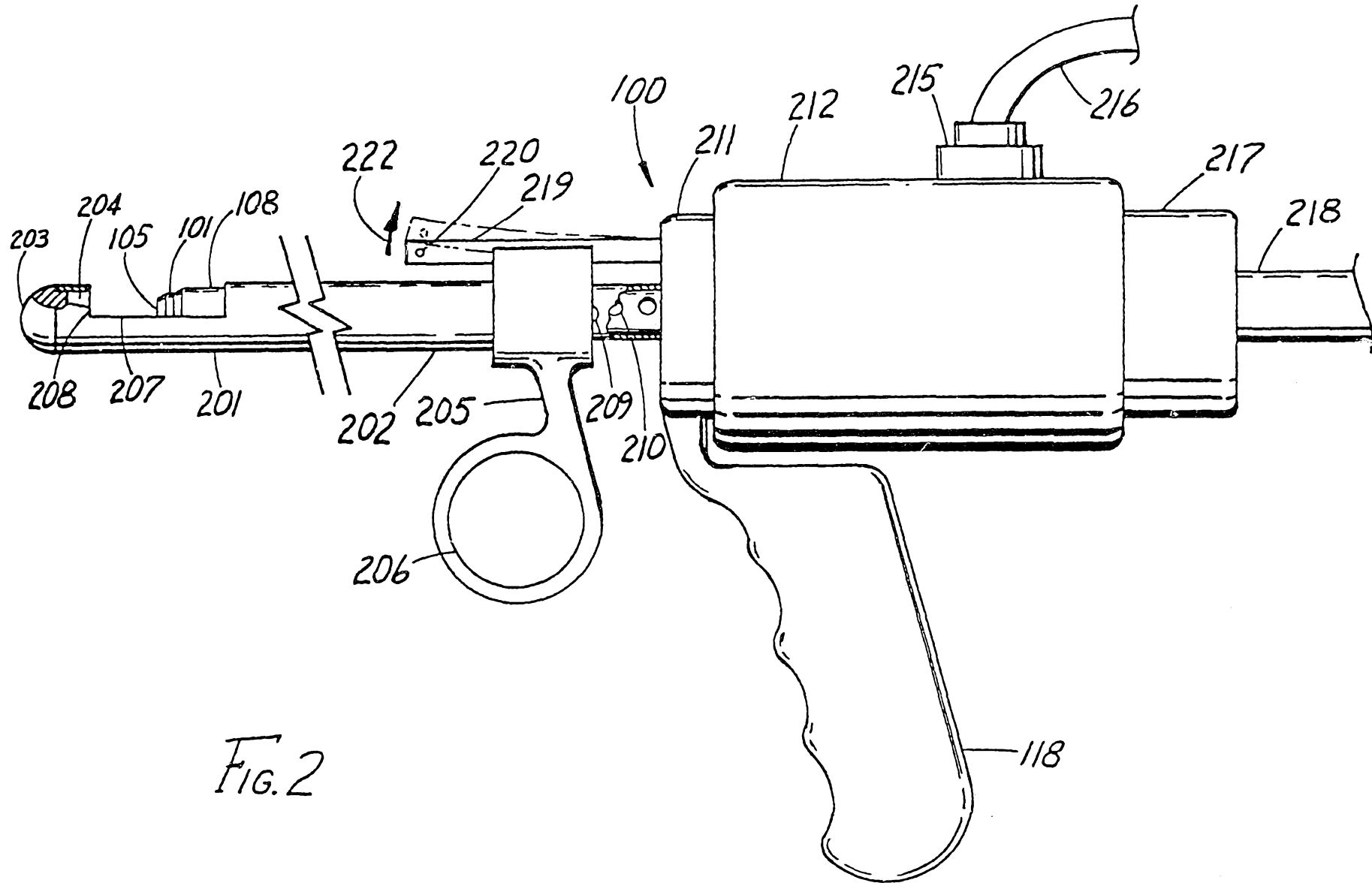

FIG. 2

0 1 1 0 2 2 0 0 0 5

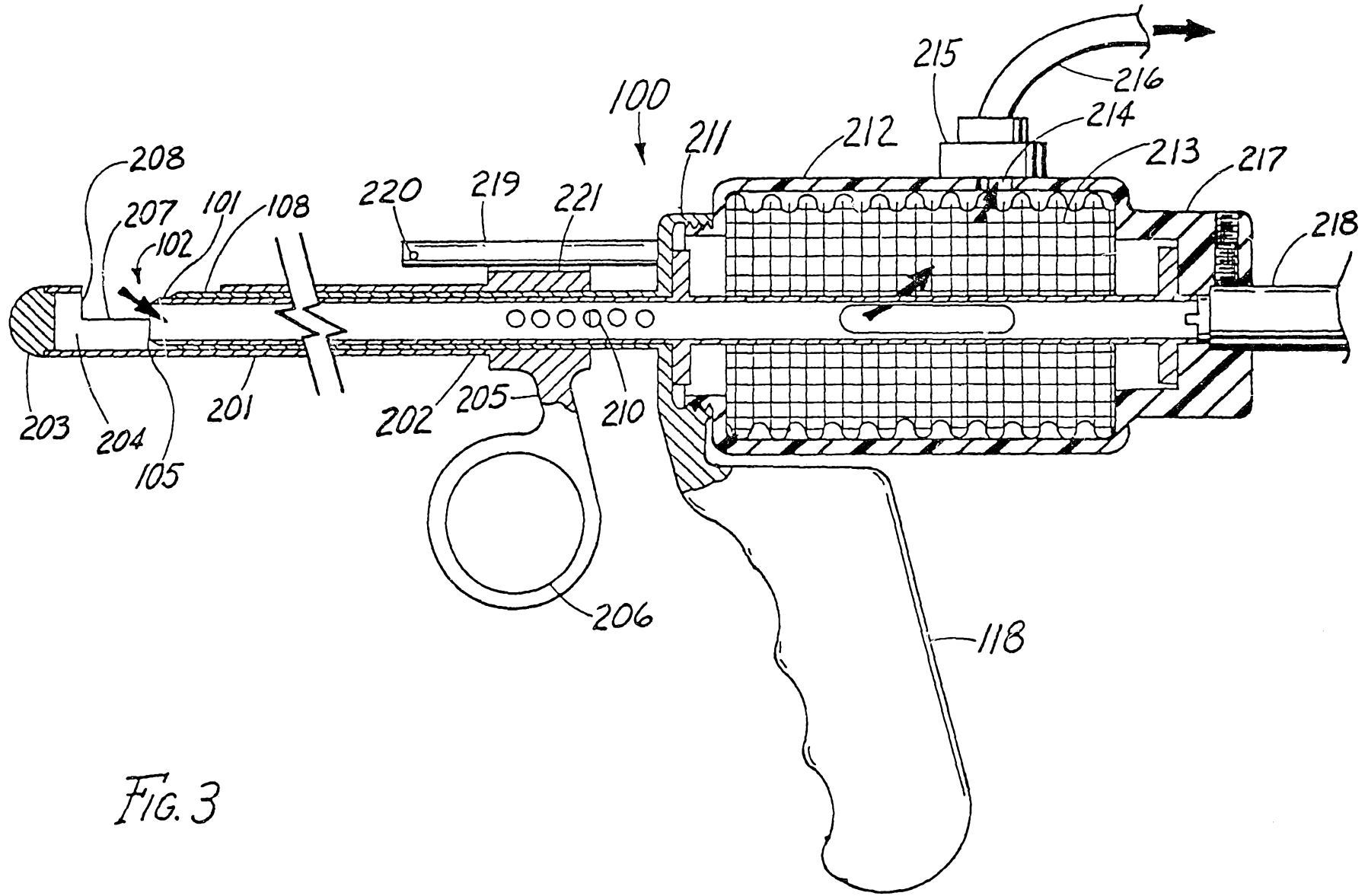

FIG. 3

0 1 1 9 2 2 0 0 5

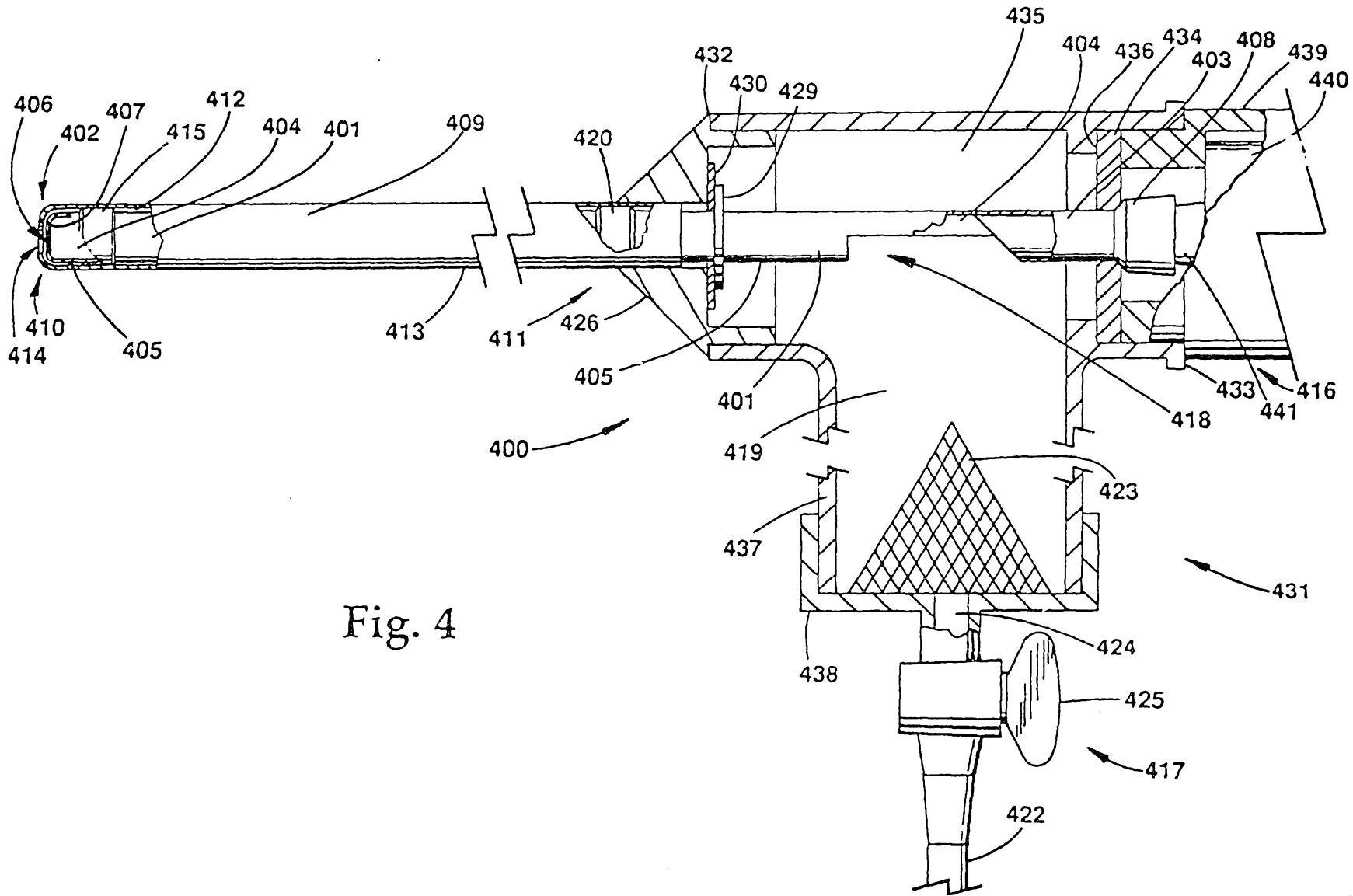

Fig. 4

4/5

28206/92

28206/92

5/5

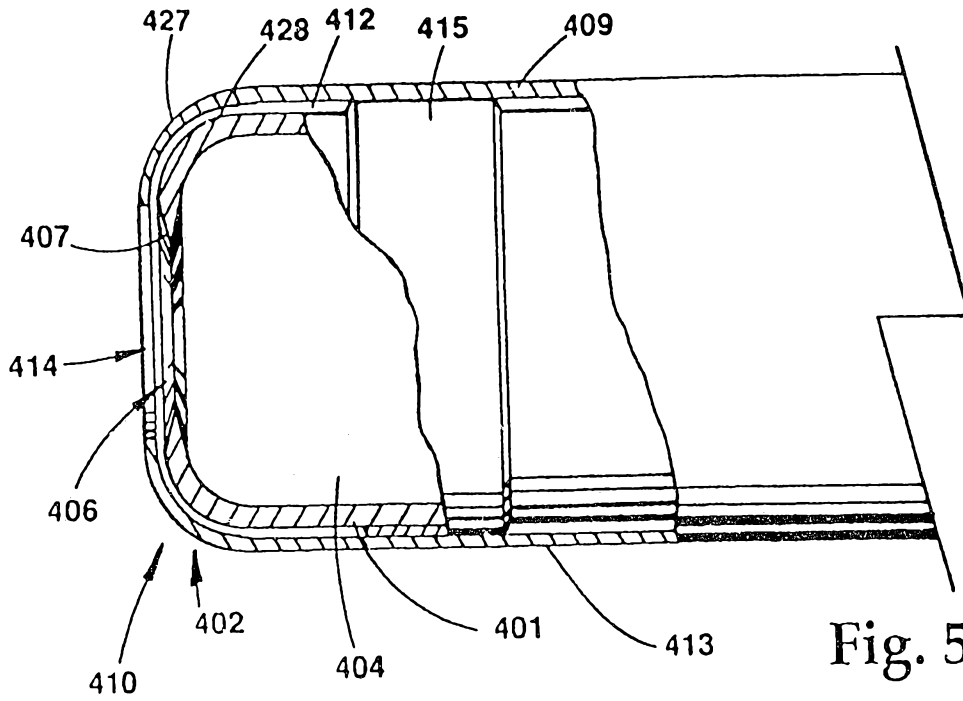

Fig. 5

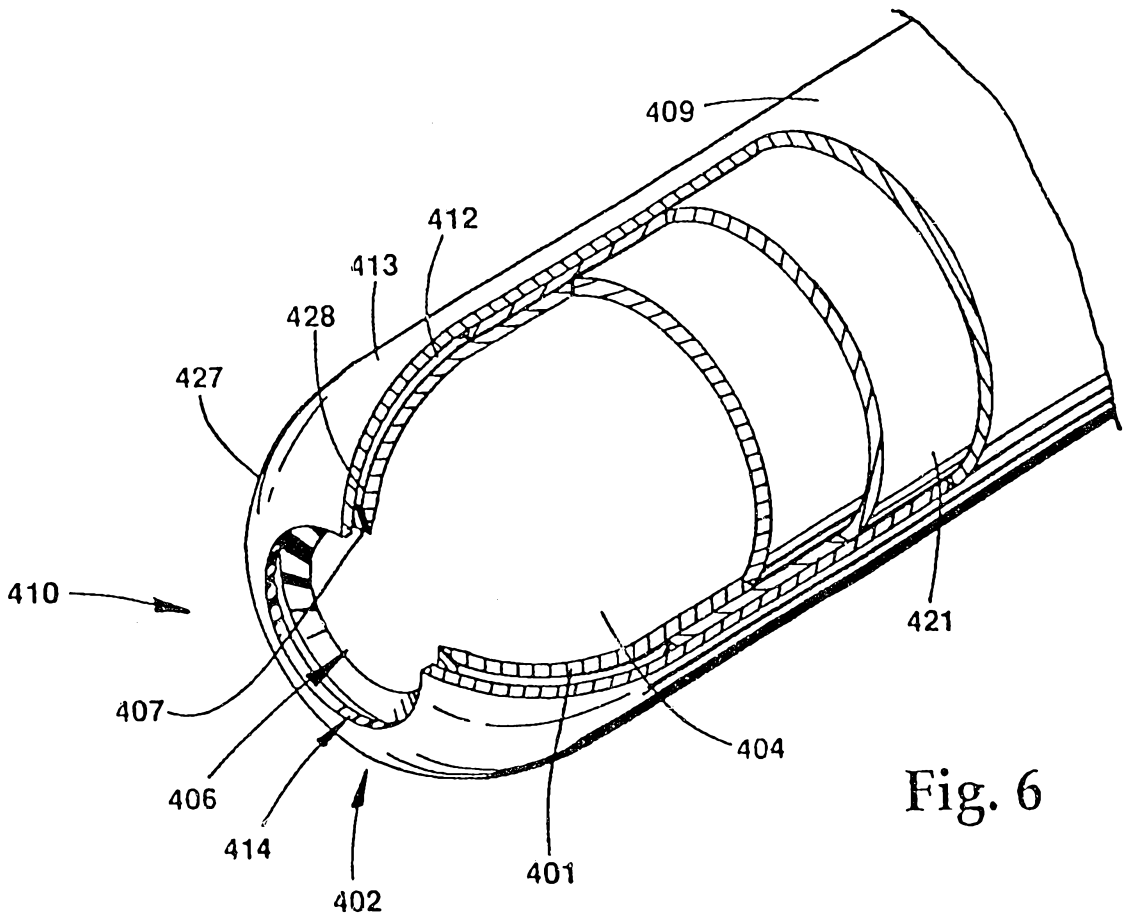

Fig. 6

