

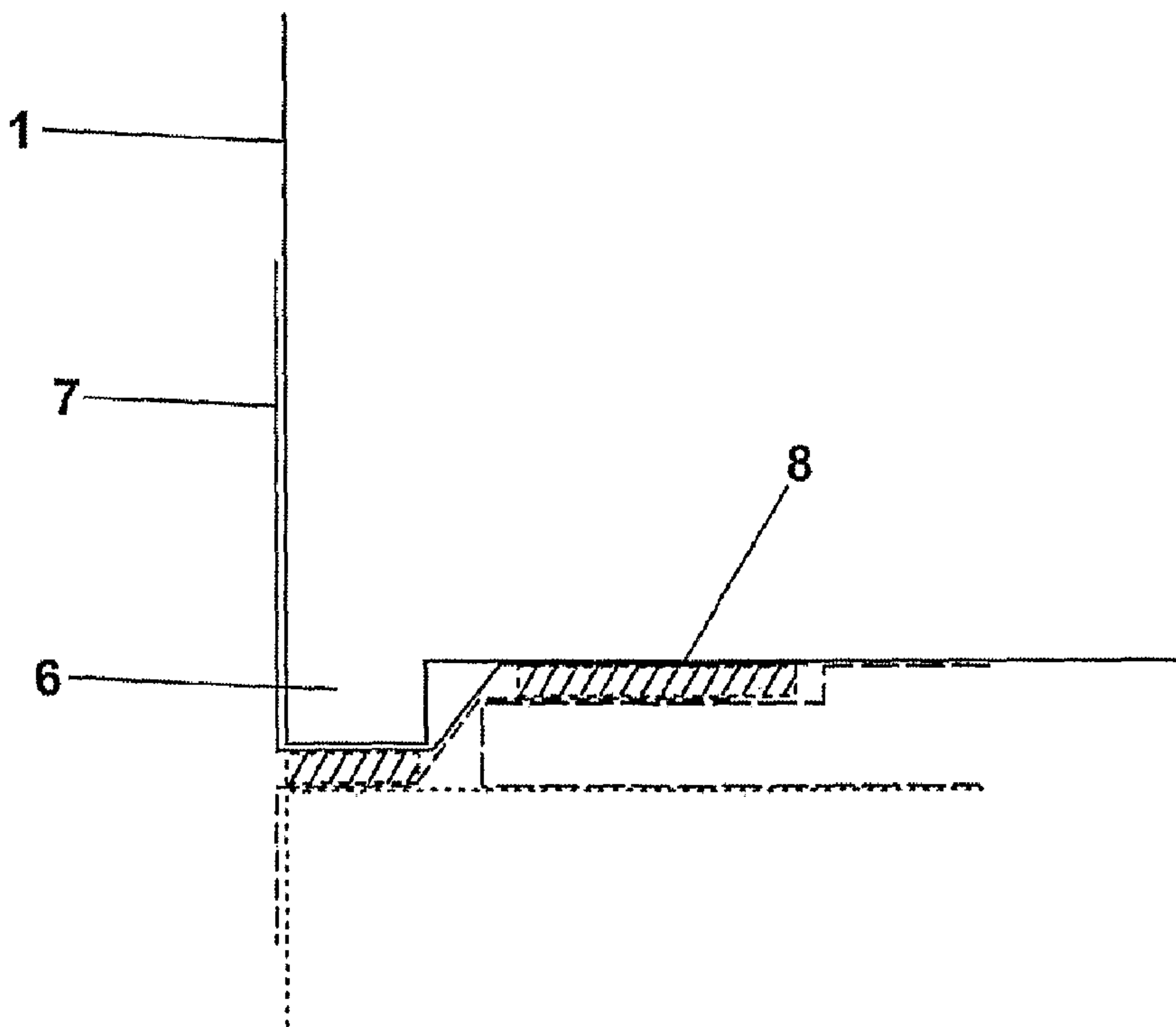

(86) Date de dépôt PCT/PCT Filing Date: 2003/12/03
 (87) Date publication PCT/PCT Publication Date: 2004/06/17
 (45) Date de délivrance/Issue Date: 2008/02/26
 (85) Entrée phase nationale/National Entry: 2005/06/02
 (86) N° demande PCT/PCT Application No.: GB 2003/005280
 (87) N° publication PCT/PCT Publication No.: 2004/051018
 (30) Priorité/Priority: 2002/12/03 (GB0228173.1)

(51) Cl.Int./Int.Cl. *E04B 1/348* (2006.01),
E04B 1/00 (2006.01)
 (72) Inventeur/Inventor:
WINDOW, JOHN, GB
 (73) Propriétaire/Owner:
HENLEY TECHNOLOGY LTD., GB
 (74) Agent: MACRAE & CO.

(54) Titre : ALIGNEMENT VERTICAL ET NIVELLEMENT D'UNITES DE CONSTRUCTION MODULAIRES
 (54) Title: VERTICAL ALIGNMENT AND LEVELLING OF MODULAR BUILDING UNITS



(57) Abrégé/Abstract:

The invention provides a modular building unit (1) comprising walls, a floor and a ceiling, which is preferably assembled off-site and furnished or fitted out off-site prior to being transported to a building site for assembly in a stack as a vertical and horizontal array to form a building. The modular building unit is essentially a lined shell defining the walls of a room. Vertical location of one such modular building unit (1) on the unit below it in the stack is established by a downwardly extending location flange (6) around the outside bottom edge of each module, engaging in a peripheral recess (2b, 2c) around the top perimeter of the outside top edge of the vertically adjacent module beneath it in the stack.

(12) INTERNATIONAL APPLICATION PUBLISHED UNDER THE PATENT COOPERATION TREATY (PCT)

(19) World Intellectual Property
Organization
International Bureau



(43) International Publication Date
17 June 2004 (17.06.2004)

PCT

(10) International Publication Number
WO 2004/051018 A1

- (51) International Patent Classification⁷: **E04B 1/348**
- (21) International Application Number:
PCT/GB2003/005280
- (22) International Filing Date: 3 December 2003 (03.12.2003)
- (25) Filing Language: English
- (26) Publication Language: English
- (30) Priority Data:
0228173.1 3 December 2002 (03.12.2002) GB
- (71) Applicant and
(72) Inventor: **WINDOW, John** [GB/GB]; Bishops House, 37
The Green, Great Bowden, Market Harborough, Leicester-
shire LE16 7EU (GB).
- (74) Agent: **SERJEANTS**; 25 The Crescent, King Street, Le-
icester LE1 6RX (GB).
- (81) Designated States (*national*): AE, AG, AL, AM, AT, AU, AZ, BA, BB, BG, BR, BY, BZ, CA, CH, CN, CO, CR, CU, CZ, DE, DK, DM, DZ, EC, EE, ES, FI, GB, GD, GE, GH, GM, HR, HU, ID, IL, IN, IS, JP, KE, KG, KP, KR, KZ, LC, LK, LR, LS, LT, LU, LV, MA, MD, MG, MK, MN, MW, MX, MZ, NI, NO, NZ, OM, PG, PH, PL, PT, RO, RU, SC, SD, SE, SG, SK, SL, SY, TJ, TM, TN, TR, TT, TZ, UA, UG, US, UZ, VC, VN, YU, ZA, ZM, ZW.
- (84) Designated States (*regional*): ARIPO patent (BW, GH, GM, KE, LS, MW, MZ, SD, SL, SZ, TZ, UG, ZM, ZW), Eurasian patent (AM, AZ, BY, KG, KZ, MD, RU, TJ, TM), European patent (AT, BE, BG, CH, CY, CZ, DE, DK, EE, ES, FI, FR, GB, GR, HU, IE, IT, LU, MC, NL, PT, RO, SE, SI, SK, TR), OAPI patent (BF, BJ, CF, CG, CI, CM, GA, GN, GQ, GW, ML, MR, NE, SN, TD, TG).
- Published:**
— with international search report
- For two-letter codes and other abbreviations, refer to the "Guidance Notes on Codes and Abbreviations" appearing at the beginning of each regular issue of the PCT Gazette.*

(54) Title: VERTICAL ALIGNMENT AND LEVELLING OF MODULAR BUILDING UNITS

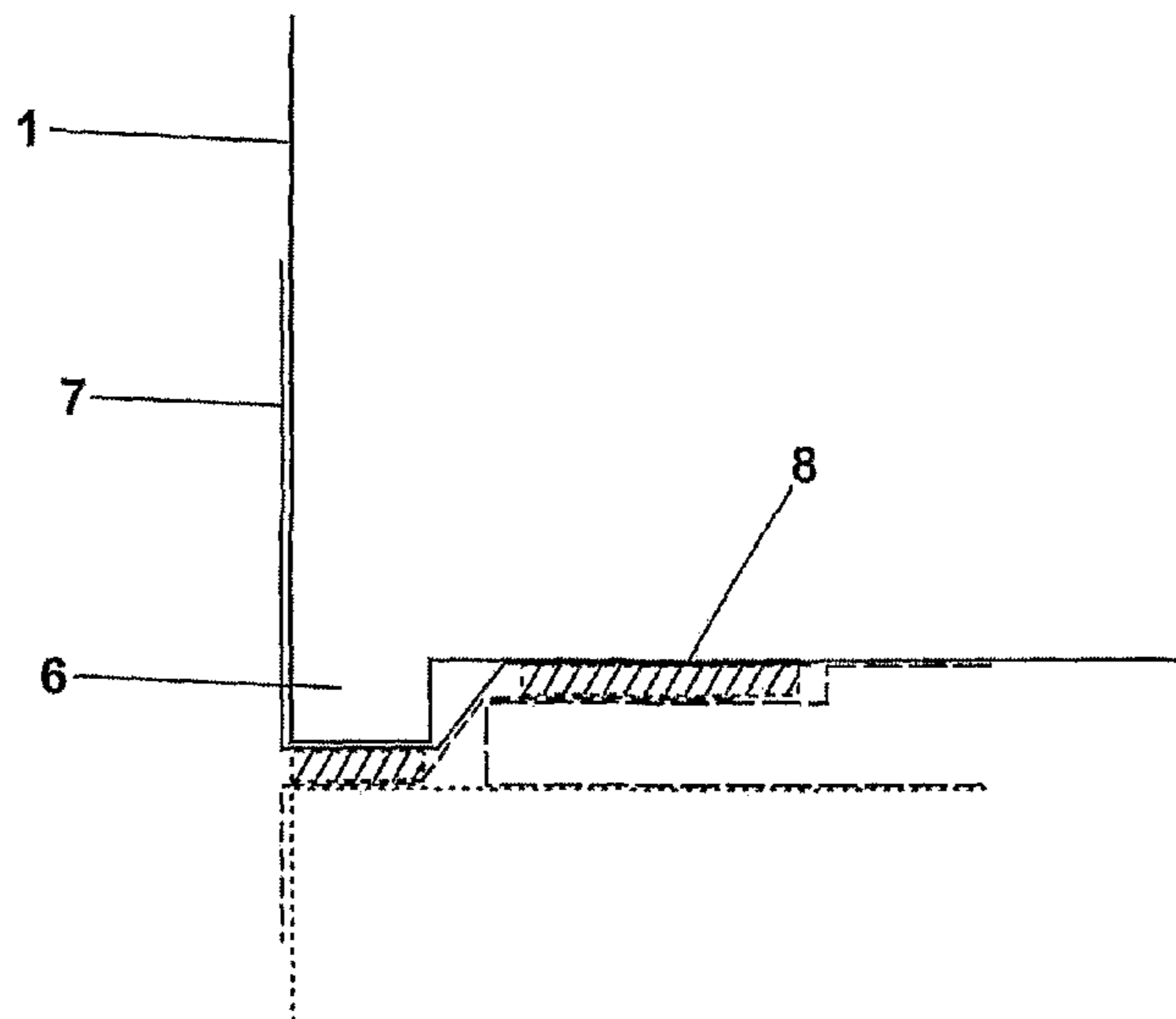

(57) Abstract: The invention provides a modular building unit (1) comprising walls, a floor and a ceiling, which is preferably assembled off-site and furnished or fitted out off-site prior to being transported to a building site for assembly in a stack as a vertical and horizontal array to form a building. The modular building unit is essentially a lined shell defining the walls of a room. Vertical location of one such modular building unit (1) on the unit below it in the stack is established by a downwardly extending location flange (6) around the outside bottom edge of each module, engaging in a peripheral recess (2b, 2c) around the top perimeter of the outside top edge of the vertically adjacent module beneath it in the stack.

WO 2004/051018 A1

- 1 -

TITLE:

Vertical Alignment and levelling of Modular Building Units

DESCRIPTION5 Field of the Invention

The invention relates to modular building units for use in the construction of largely prefabricated offices, hotels and apartment blocks, and buildings of a similar general nature. Such modular building units are box-like structures which can be manufactured and fitted-out off-site and then transported to a construction site for final assembly to form the internal rooms of a building. The invention also relates to a method for the erection of buildings using such modular building units, and in particular to the alignment of such a building and the levelling of the lower or ground floor units.

15 Background Art

Particularly in the construction of hotels, apartments and student accommodation it is known to construct the buildings from lightweight building modules each of which is a skeletal steel shell formed from lightweight structural steel sections welded into a box-like structure and lined with boarding such as plasterboard, plywood or oriented strand board (OSB). Each building module is made initially as such a lined shell, and is then fitted-out to the desired standard of internal decoration in a factory before being transported to the final building site for incorporation into a building. Other building modules are known, made primarily from wood frames and wood boarding.

At the building site, the modules are hoisted by crane from the lorry or truck on which they had been transported, and stacked in a vertical and horizontal array cooperating to form the linked rooms of the final building. For low-rise buildings, the accuracy required in the stacking process is relatively crude. It makes very little difference to the final stability of the building whether the individual modules are accurately positioned vertically one over the other, and

- 2 -

generally it is considered to be adequate for the individual modular building units to be manipulated into their final positions by hand as they are lowered by crane. For progressively higher rise buildings, the accuracy of the vertical alignment of the individual building units in the array becomes of increasing importance. Hitherto, however, the accuracy of the stacking has depended entirely on the skill of the crane driver in being able to hold the topmost building unit static, while skilled workers manoeuvre it manually into the correct vertically aligned position, before the tension in the crane cable is released and the building unit takes up its final position over the lower units in the stack.

It is an object of this invention to provide, for such a modular building unit and building system, a means for automatically and accurately aligning the vertically adjacent building units in the stack. By making the alignment automatic and largely unreliant on the skill of the building workers manoeuvring the modular building units into position, it is possible to increase the height of buildings made from such modular units using unskilled labour, from a previous practical maximum of about five storeys to from twenty to thirty storeys.

20

The invention

The invention comprises a modular building unit as specified in claims 1 to 6 herein. The edge location means, provided by the cooperating location flange and peripheral recess of vertically adjacent modules, makes it possible accurately to position the modular building units one above the other in the array with the minimum reliance on skilled labour. Preferably the peripheral recess has an inside side wall which slopes upwardly and inwardly relative to the building module, to guide the vertically adjacent building module into position when stacking the modules one above the other during the erection of a building therefrom. Therefore the erection team manhandling the module into position as it is lowered by crane simply have to guide the module being hoisted into position to within about two or three centimetres of its final

30

- 3 -

position, and the sloping inside side wall of the peripheral recess is sufficient to guide the module into its precise final position.

5 The building modules according to the invention may be constructed as described and claimed in copending Patent Application No. W068004 filed herewith and linked together horizontally and vertically as described in W068006 filed herewith. They may be made from a lined skeletal shell of structural building elements as described and claimed in copending Patent Application No. W068007 filed herewith.

10

The invention also provides a levelling unit for a building module according to the invention, as specified in claim 7 herein. Finally, the invention provides a method of building as specified in claim 8 herein.

15 Drawings

Figure 1 is a perspective view of a modular building unit according to the invention;

Figure 2 is a section taken along the line A-A of a top corner of the building unit of Figure 1;

20 Figure 3 is a section taken along the line B-B through a bottom corner of the building unit of Figure 1; and

Figure 4 is a perspective view of a levelling unit for use with the modular building unit of Figures 1 to 3.

25 Figure 1 is a perspective view of a complete building module 1, constructed according to my copending Patent Application No W068004 and provided in addition with edge location means in accordance with this invention. The module comprises four walls, a floor and a roof. One end wall is shown in Figure 1 as having a window. The opposite end wall (not visible) would have
30 a door. The window wall would be on the outside of the assembled building and the door wall would be on the inside, with the doors opening for example onto a corridor providing access to any of the modules in a given row.

- 4 -

5 Around the outer edge of the top of the module 1 is a peripheral recess which is defined by a corner strip 2, as shown in Figure 2. The corner strip 2 is made from lightweight cold-formed structural steel by a folding or creasing operation, and comprises a front face 2a, a lower top face 2b, an inclined face 2c and an upper top face 2d. The front face 2a is secured to the structural uprights of the modular building unit, for example by spot welding or plug welding. The lower top face 2b lies over the horizontally aligned top ends of those structural uprights. Between the lower top face 2b and the inclined face 10 2c is formed the peripheral recess which extends around all four edges of the top of the module 1.

15 The top of the module 1 is externally boarded with load-bearing panels 3 which are strong enough to bear the weight of the construction team members who are employed to erect a building from a number of such modular units. The upper top face 2d of the corner strip 2 lies in a recess formed in the top of the load-bearing panels 3, and over the upper top face 2d is adhered a strip 4 of acoustic insulation, for example a strip of rubber or elastomeric material such as high density neoprene foam. Another such strip 5 of acoustic 20 insulation is adhered over the lower top face 2b of the corner strip 2, so as to provide good acoustic insulation between vertically adjacent stacked modules 1. An alternative sound insulation barrier could be obtained by laying the corner strip 2 over a layer of rubber or elastomeric or other sound-absorbing lining.

25 Figure 3 shows the detail of the bottom periphery of each module 1, and also shows how that bottom detail cooperates with the peripheral recess around the top edge of the module vertically beneath it in the final building. That module beneath is shown in Figure 3 in broken line, but is exactly as 30 described above with reference to Figure 2. In Figure 3 the strips 4 and 5 of acoustic insulation are shown compressed, as they would be in practice, by the weight of the module or modules 1 vertically above.

- 5 -

The bottom detail of the module 1 is provided by a corner strip cold-formed so as to define a downwardly extending locating flange 6 into which the structural uprights (not shown) of the module rest. An outer wall of the flange 6 extends upwardly as an outside wall portion 7 of the corner strip, which is secured to the outside of the skeletal building module 1 by spot welding or plug welding for example. The inner wall of the flange 6 is bent to follow the angle of the inclined face 2c of the top corner strip 2, terminating in a bottom plate portion 8 which is welded to the bottoms of an array of cross-beams (not shown) which support the floor of the module 1. Although welding has been specified as the securing method of choice in the particular example illustrated, other securing methods such as bolts, rivets or even adhesive are feasible alternatives depending on the permanence of the intended building and the stresses to which it is expected to be exposed.

When erecting a building from a number of modules according to the invention, a lowermost array of modules 1 is first manoeuvred into position and anchored to foundations. Then one by one the modules 1 of the next storey are hoisted into position by crane. As the modules 1 are lowered by the crane operator, they are pushed into position by a crew. The edge location provides accurate positioning of the modules on the modules of the floor below, and the workmen can walk freely on the roofs of the ground floor array of modules 1 because the top boarding 3 is load-bearing.

When each upper storey module 1 is approximately in position, the crane driver lowers it its last few centimetres, and the inclined faces 2c guide it gently but accurately into register with the module below.

The assembled modules may be locked together as described and claimed in my copending Patent Application No. W068006. Alternatively a continuous cable may be threaded through the wall cavities defined by mutually aligned vertical structural uprights of successive storeys of the building and tensioned

- 6 -

as a continuous cable run from the building foundations to roof, to lock together the modules vertically. Instead of a cable, a series of interconnected tubes or rods may be used, each one storey in height, as described in my copending Application No W068007. Similar interconnected tubes or rods may be used across the building in the horizontal plane, but generally it will be sufficient to connect the modules together horizontally using gutter plates straddling the roves of horizontally adjacent modules, which for sound insulation purposes are usually stacked with a small horizontal gap therebetween. The gutter plates not only tie the adjacent modules together horizontally but also prevent the ingress of rain between adjacent modules during erection.

Figure 4 shows a levelling unit which in practice is laid over the foundations or any given course of a building and accurately levelled before the next courses of building modules are hoisted into position. The levelling unit of Figure 4 is given the general reference 10 and comprises a peripheral structure of C-sections 11, each made from lightweight cold-formed structural steel. Running in parallel between the C-sections 11 forming the long edges of the base levelling unit 10 are an array of C-section cross-beams 12, each connected to the corresponding C-section peripheral beam 11 in exactly the same way as the floor and ceiling cross-beams are connected in the building modules of Figures 1 to 3. For additional rigidity, spacers (not shown) of C-section may be welded at staggered intervals between adjacent pairs of cross-beams 12, to create an overall rigid assembly. If desired, although not shown in Figure 4, that assembly can be clad over its top surface with load-bearing flooring similar to the boarding 3 of Figure 2.

Around the outside edge of the base levelling unit 10 (although again not shown in Figure 4) is a corner strip defining a peripheral recess exactly the same as the corner strip 2 described and illustrated with reference to Figure 2 around the top of each complete building module according to the invention. Thus Figure 2 could equally be a section through one of the edges of the base

- 7 -

levelling unit 10 of Figure 4, except that the line in Figure 2 referenced 1 and indicating the building module would in fact indicate the outside wall of the levelling unit 10 and the C-section peripheral members 11.

5 In use, it is far easier to handle a levelling unit 10 than a complete fitted-out building module 1. Therefore after preparing the foundations of the building, one such levelling unit 10 is placed in position to define the footprint of each room to be created on successive floors of the finished building. Levelling of the individual levelling units 10 can be achieved by the insertion of metal
10 shims or by the use of screw jacks, and is carried out with precision until an accurate level base or lower level course is created for the upper courses of the individual building modules 1 of the finished building. As each levelling unit 10 is accurately positioned and levelled, it may be secured to the foundations or ground level structure by anchor bolts, tie straps or other
15 appropriate anchorage means (not shown) so that the base course for the upper storeys of the building is both accurately levelled and secured to the foundations or ground level structure.

Thereafter, individual building modules 10 are hoisted into position by a crane
20 and are located by the edge recesses in the levelling units 10, exactly as described above in relation to the accurate assembly of the upper storeys of the building.

CLAIMS:

1. A modular building unit comprising a skeletal shell lined to define the walls of a room or rooms, the building units when stacked in a vertical and horizontal array cooperating to form the linked rooms of a building, **characterized in that** for precise location of one module or part thereof vertically over another in the resulting building, each module is provided around the perimeter of its base with a downwardly extending location flange, and each module is also provided with an external roof covering of load-bearing boarding which extends close to but not up to the outside perimeter of the top of the module, and the external perimeter of the module is clad with an edging of cold-formed lightweight steel which has a first portion which laps around the top of the side and end walls of the module and a second portion which laps over the outside edge of the boarding, so that between the first and second portions of the edging is formed a peripheral locating recess into which the location flange of a vertically adjacent building module can accurately locate.
5
10
2. A modular building unit according to claim 1, wherein the peripheral recess has an inside side wall which slopes upwardly and inwardly relative to the building module, to guide the vertically adjacent building module into position when stacking the modules one above the other during the erection of a building therefrom.
15
3. A modular building unit according to claim 1 or claim 2, wherein the modular building unit comprises a skeletal shell of structural steel uprights and cross-members lined to define the walls of the room.
20
4. A modular building unit according to any one of claims 1 to 3, wherein the lined skeletal shell is clad with an external roof covering of load-bearing boarding which extends close to but not up to the outside perimeter of the top of the module, so that the edge of the boarding lies along the inside edge of the locating recess.

5. A modular building unit according to any one of claims 1 to 4, wherein the locating recess is lined with a rubber or elastomeric or other sound-absorbing lining.

6. A modular building unit according to any one of claims 1 to 4, wherein the edging of cold-formed lightweight steel is laid over a layer of a rubber or elastomeric or other sound-absorbing lining.

7. A method of building using modular building units according to any one of claims 1 to 6, wherein one or more levelling units each comprising a skeletal shell of structural steel peripheral members and cross-members defining a footprint of a modular building unit according to any one of claims 1 to 6 are positioned over a foundation or ground level structure of the building, and each is accurately levelled and located relative to the adjacent levelling units by the use of shims or screw jacks between the levelling units and the building foundations or ground level structure; and the levelling units are secured fast to the building foundations or ground level structure prior to placing individual modular building units thereon, and locating those modular building units by engagement of the generally extending location flange around the perimeter of the base of each building unit into a peripheral recess formed around the respective levelling unit into which the location flange of the corresponding modular building unit can accurately locate.

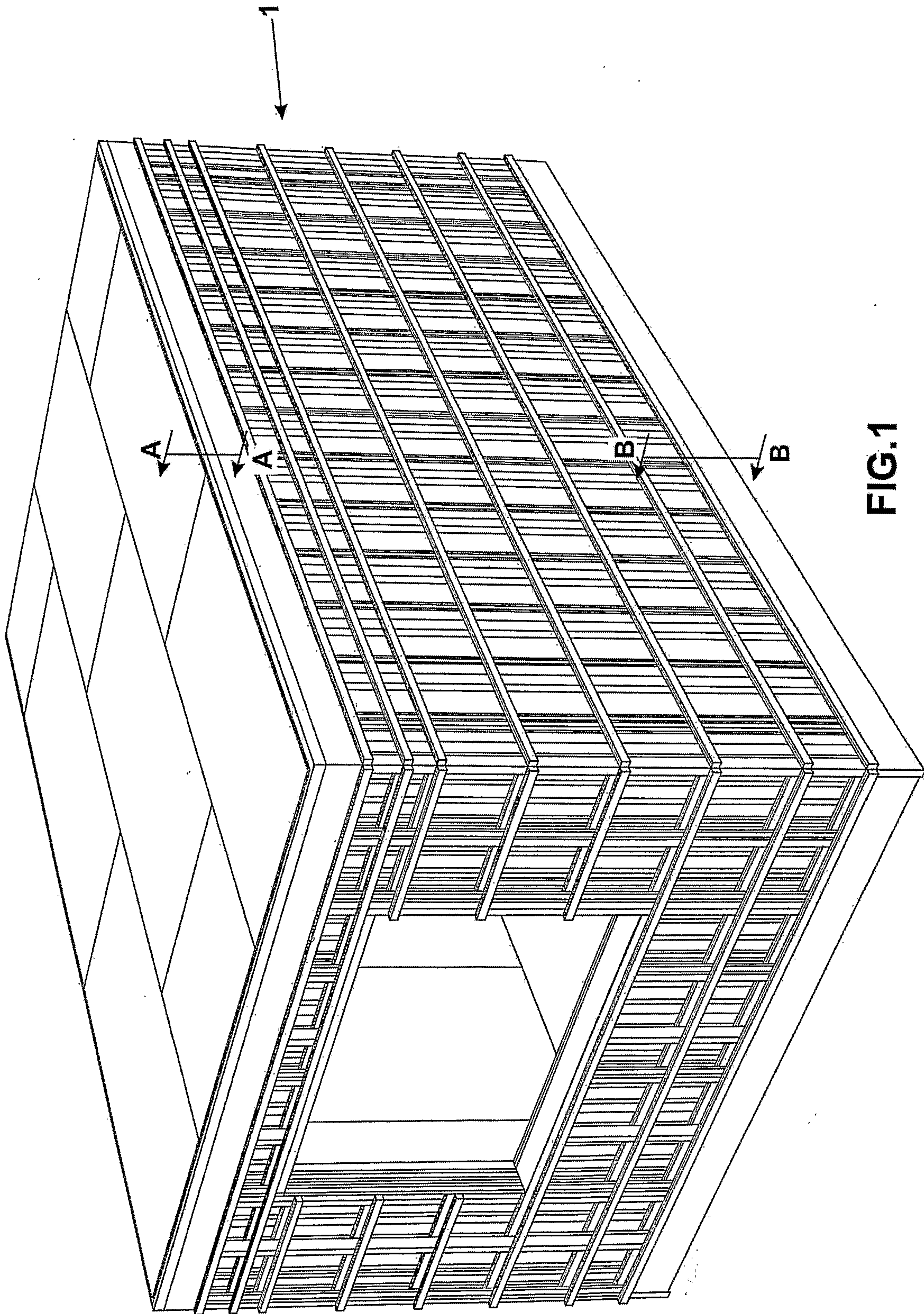
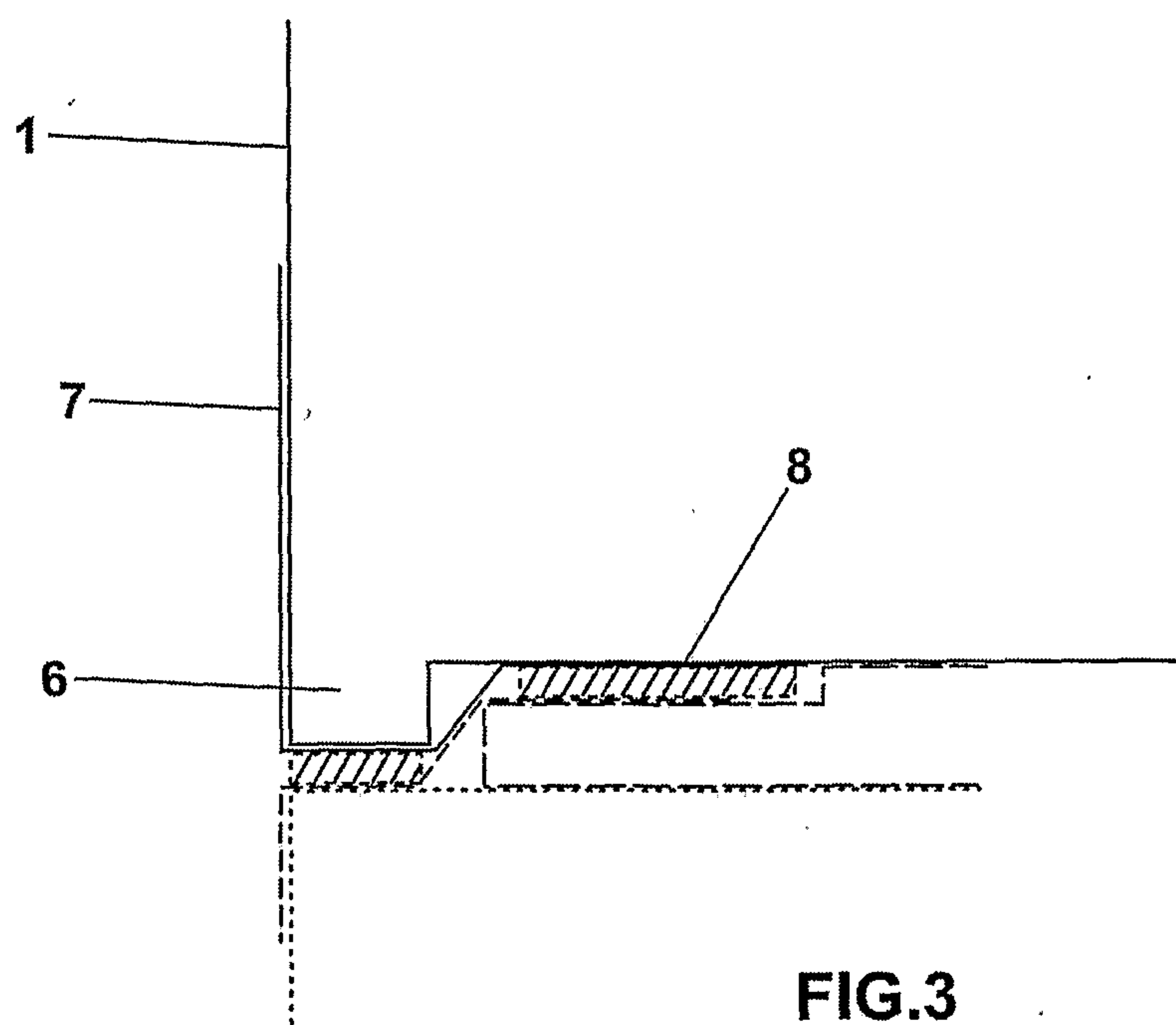
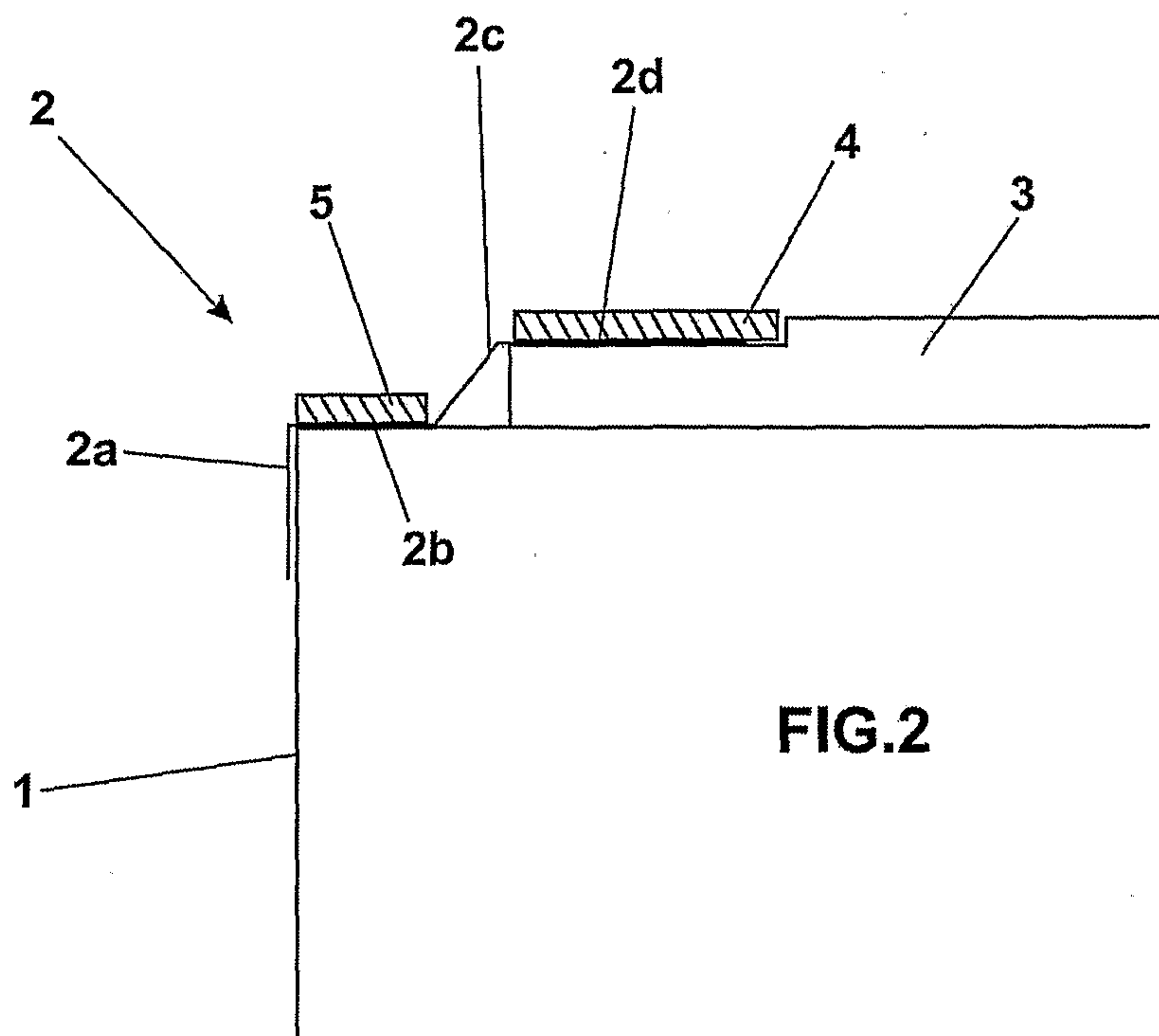

FIG.1



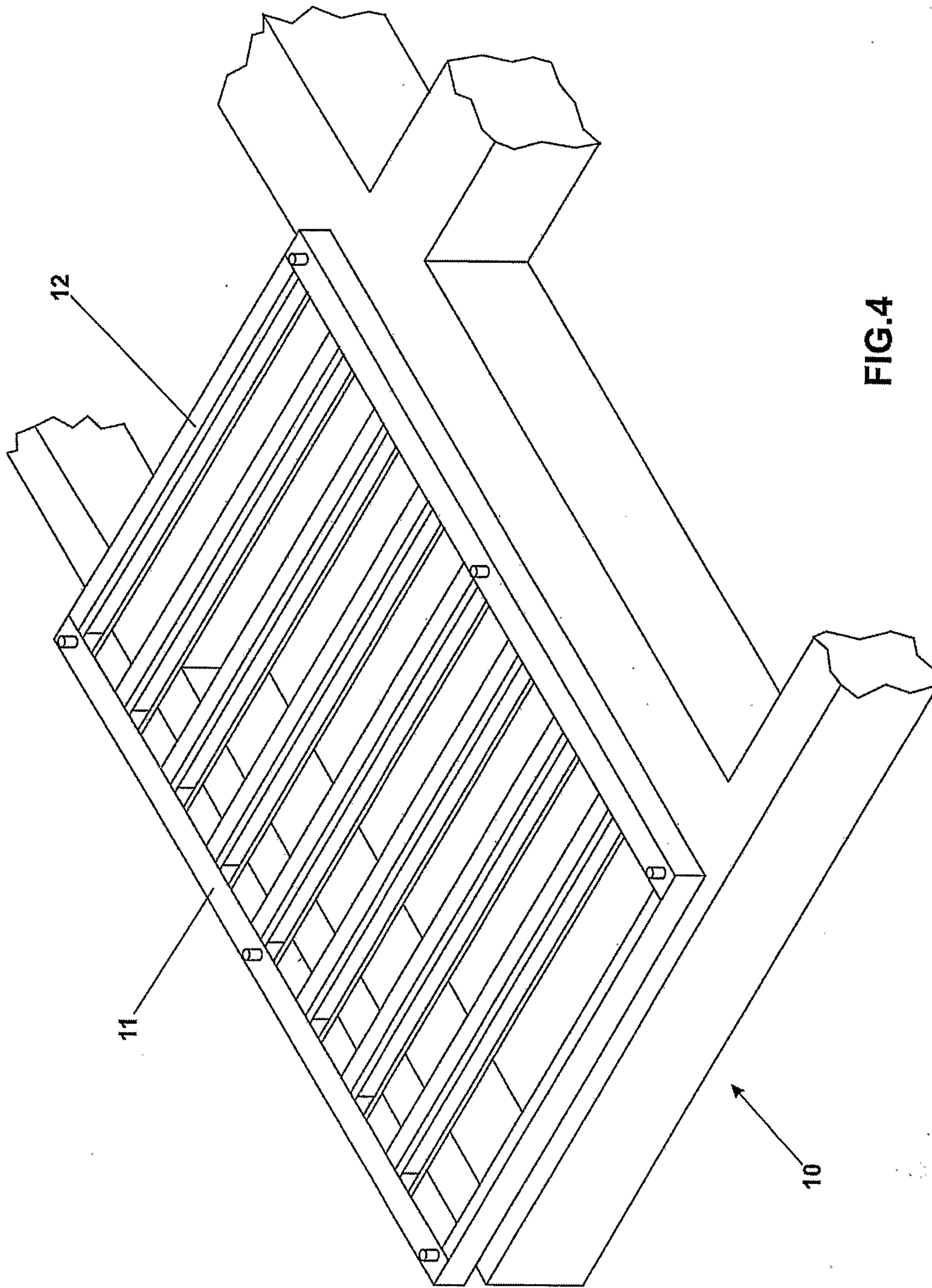

FIG.4

