

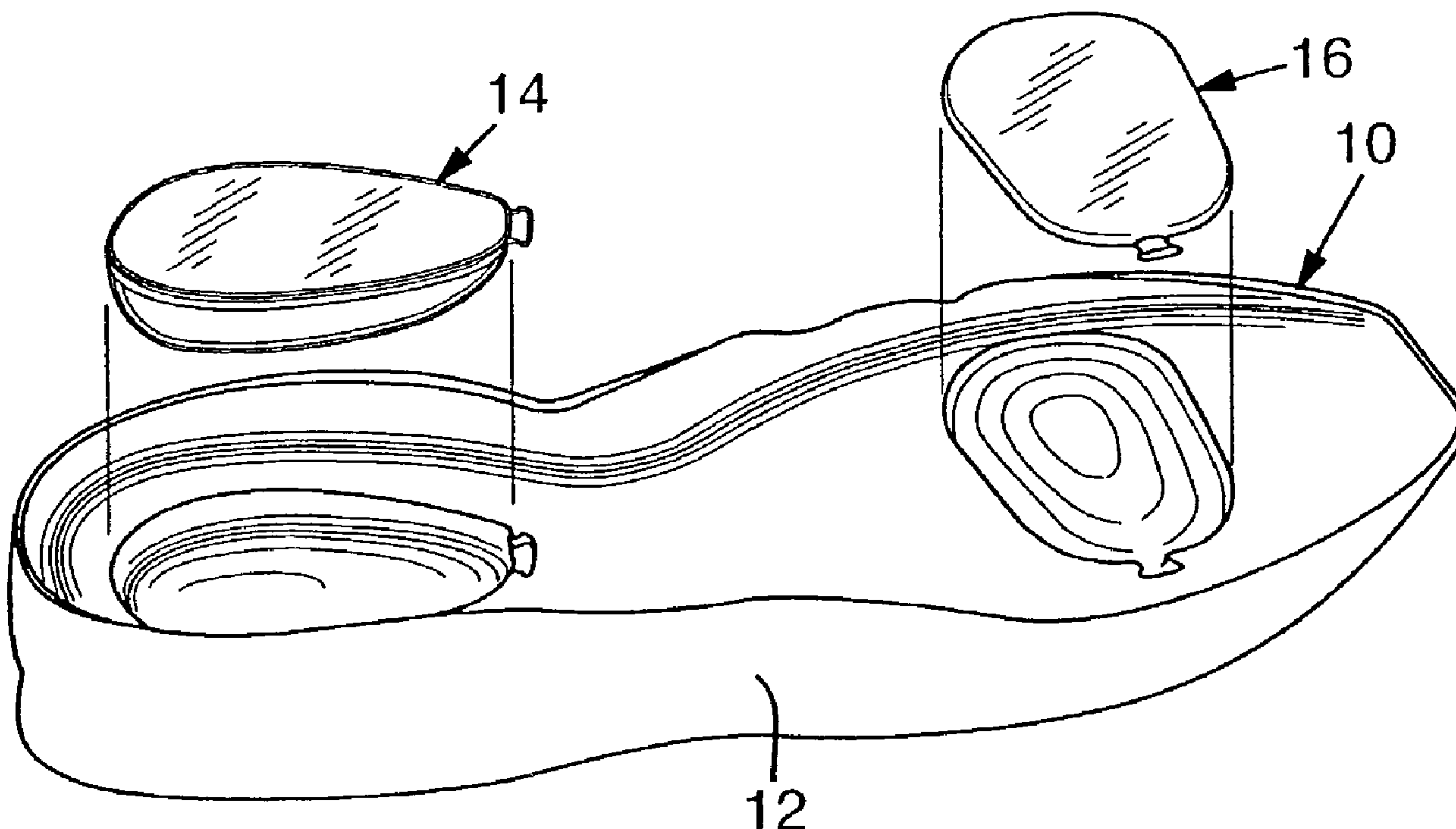

(86) Date de dépôt PCT/PCT Filing Date: 2003/05/08
 (87) Date publication PCT/PCT Publication Date: 2003/11/20
 (45) Date de délivrance/Issue Date: 2009/02/17
 (85) Entrée phase nationale/National Entry: 2004/11/01
 (86) N° demande PCT/PCT Application No.: US 2003/014399
 (87) N° publication PCT/PCT Publication No.: 2003/094645
 (30) Priorité/Priority: 2002/05/09 (US10/143,745)

(51) Cl.Int./Int.Cl. *A43B 13/20* (2006.01)
 (72) Inventeur/Inventor:
 SWIGART, JOHN F., US
 (73) Propriétaire/Owner:
 NIKE INTERNATIONAL LTD., US
 (74) Agent: SMART & BIGGAR

(54) Titre : SEMELLE DE CHAUSSURE DOTEES D'UNE SEULE CAVITE ETANCHE
 (54) Title: FOOTWEAR SOLE COMPONENT WITH A SINGLE SEALED CHAMBER



(57) **Abrégé/Abstract:**

A sole component for footwear combining the desirable response characteristics of a fluid filled chamber and an elastomeric material. The chamber (14, 14') can be formed as a single bladder chamber (14, 16) in contact with an elastomeric midsole (12), or a single chamber formed by a sealing (19) a void in elastomeric material. The interface between the chamber and elastomeric material is sloped and gradual so that the shape of the chamber and its placement in a midsole determine the combination of response characteristics in the sole component. The chamber (14, 14') has a relatively simple shape with one axis of symmetry with a rounded portion (27) and a narrow portion (29). Varying the placement of the chamber in the elastomeric material can simulate the impact response of more complex and expensive systems with only a single chamber shape that needs to be stocked. The

(57) **Abrégé(suite)/Abstract(continued):**

chamber has a relatively large volume, is devoid of internal connections, and has an internal pressure within 5 psi if ambient pressure, and preferably at ambient pressure. Since air is used as the fluid, no specialized gases are required. No specialized films or bladder materials are required where the chamber is formed as a bladder, since the bladder is not highly pressurized. Manufacture is simplified and design flexibility enhanced with only one type of air chamber.

(12) INTERNATIONAL APPLICATION PUBLISHED UNDER THE PATENT COOPERATION TREATY (PCT)

(19) World Intellectual Property Organization
International Bureau



(43) International Publication Date
20 November 2003 (20.11.2003)

PCT

(10) International Publication Number
WO 03/094645 A1

- (51) International Patent Classification⁷: A43B 13/20, 13/18
- (21) International Application Number: PCT/US03/14399
- (22) International Filing Date: 8 May 2003 (08.05.2003)
- (25) Filing Language: English
- (26) Publication Language: English
- (30) Priority Data:
10/143,745 9 May 2002 (09.05.2002) US
- (71) Applicant (for JP, KR only): NIKE INC. [US/US]; One Bowerman Drive, Beaverton, OR 97005 (US).
- (71) Applicant (for all designated States except JP, KR, US): NIKE INTERNATIONAL LTD. [GB/US]; One Bowerman Drive, Beaverton, OR 97005 (US).
- (72) Inventor; and
- (75) Inventor/Applicant (for US only): SWIGART, John, F. [US/US]; 14024 NW Eagleridge Lane, Portland, OR 97229 (US).
- (74) Agent: EVANS, Thomas, L.; Banner & Witcoff, Ltd., 11th Floor, 1001 G Street, NW, Washington, DC 20001-4597 (US).
- (81) Designated States (national): AE, AG, AL, AM, AT, AU, AZ, BA, BB, BG, BR, BY, BZ, CA, CH, CN, CO, CR, CU, CZ, DE, DK, DM, DZ, EC, EE, ES, FI, GB, GD, GE, GH, GM, HR, HU, ID, IL, IN, IS, JP, KE, KG, KP, KR, KZ, LC, LK, LR, LS, LT, LU, LV, MA, MD, MG, MK, MN, MW, MX, MZ, NI, NO, NZ, OM, PH, PL, PT, RO, RU, SC, SD, SE, SG, SK, SL, TJ, TM, TN, TR, TT, TZ, UA, UG, US, UZ, VC, VN, YU, ZA, ZM, ZW.
- (84) Designated States (regional): ARIPO patent (GH, GM, KE, LS, MW, MZ, SD, SL, SZ, TZ, UG, ZM, ZW), Eurasian patent (AM, AZ, BY, KG, KZ, MD, RU, TJ, TM), European patent (AT, BE, BG, CH, CY, CZ, DE, DK, EE, ES, FI, FR, GB, GR, HU, IE, IT, LU, MC, NL, PT, RO, SE, SI, SK, TR), OAPI patent (BF, BJ, CF, CG, CI, CM, GA, GN, GQ, GW, ML, MR, NE, SN, TD, TG).
- Published:
— with international search report
- For two-letter codes and other abbreviations, refer to the "Guidance Notes on Codes and Abbreviations" appearing at the beginning of each regular issue of the PCT Gazette.

(54) Title: FOOTWEAR SOLE COMPONENT WITH A SINGLE SEALED CHAMBER

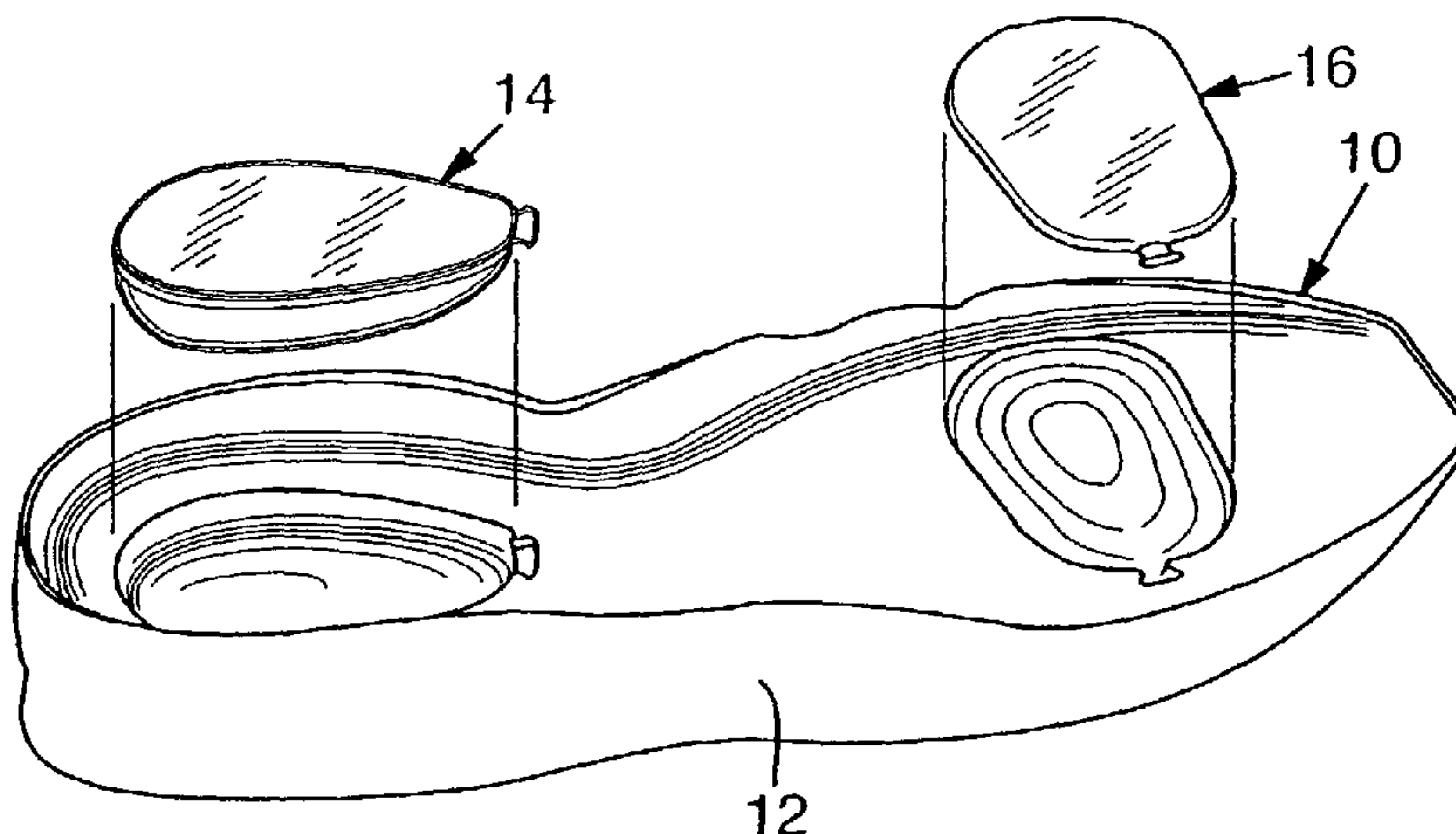

(57) Abstract: A sole component for footwear combining the desirable response characteristics of a fluid filled chamber and an elastomeric material. The chamber (14, 14') can be formed as a single bladder chamber (14, 16) in contact with an elastomeric midsole (12), or a single chamber formed by a sealing (19) a void in elastomeric material. The interface between the chamber and elastomeric material is sloped and gradual so that the shape of the chamber and its placement in a midsole determine the combination of response characteristics in the sole component. The chamber (14, 14') has a relatively simple shape with one axis of symmetry with a rounded portion (27) and a narrow portion (29). Varying the placement of the chamber in the elastomeric material can simulate the impact response of more complex and expensive systems with only a single chamber shape that needs to be stocked. The chamber has a relatively large volume, is devoid of internal connections, and has an internal pressure within 5 psi if ambient pressure, and preferably at ambient pressure. Since air is used as the fluid, no specialized gases are required. No specialized films or bladder materials are required where the chamber is formed as a bladder, since the bladder is not highly pressurized. Manufacture is simplified and design flexibility enhanced with only one type of air chamber.

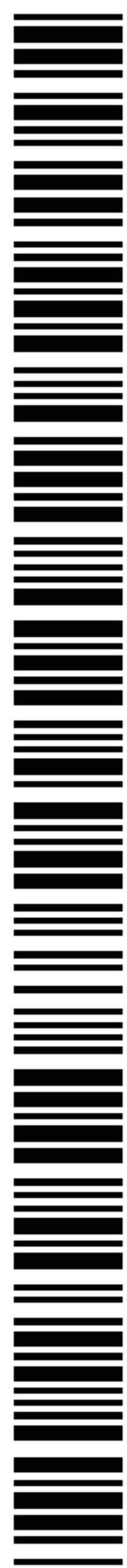

WO 03/094645 A1

FOOTWEAR SOLE COMPONENT
WITH A SINGLE SEALED CHAMBER

BACKGROUND OF THE INVENTION

1. FIELD OF THE INVENTION

[01] The present invention relates to an improved cushioning system for athletic footwear which provides a large deflection for cushioning the initial impact of footstrike, a controlled stiffness response, a smooth transition to bottom-out and stability, and more specifically to a system which allows for customization of these response characteristics by adjustment of the orientation of a single bladder in a resilient foam material.

2. DESCRIPTION OF RELATED ART

[02] Basketball, tennis, running, and aerobics are but a few of the many popular athletic activities which produce a substantial impact on the foot when the foot strikes the ground. To cushion the strike force on the foot, as well as the leg and connecting tendons, the sole of shoes designed for such activities typically include several layers, including a resilient, shock absorbent layer such as a midsole and a ground contacting outer sole or outsole which provides both durability and traction.

[03] The typical midsole uses one or more materials or components which affect the force of impact in two important ways, i.e., through shock absorption and energy dissipation. Shock absorption involves the attenuation of harmful impact forces to thereby provide enhanced foot protection. Energy dissipation is the dissemination of both impact and useful propulsive forces. Thus, a midsole with high energy

50879-3

dissipation characteristics generally has a relatively low resiliency and, conversely, a midsole with low energy dissipating characteristics generally has a relatively high resiliency. The optimum midsole should be designed with an impact response that takes into consideration both adequate shock absorption and sufficient resiliency.

[04] One type of sole structure in which attempts have been made to design appropriate impact response are soles, or inserts for soles, that contain a bladder element of either a liquid or gaseous fluid. These bladder elements are either encapsulated in place during the foam midsole formation or dropped into a shallow, straight walled cavity and cemented in place, usually with a separate piece of foam cemented on top. Particularly successful gas filled structures are disclosed in U.S. Patent Nos. 4,183,156 and 4,219,945 to Marion R. Rudy. An inflatable bladder or barrier member is formed of an elastomeric material having a multiplicity of preferably intercommunicating, fluid-containing chambers inflated to a relatively high pressure by a gas having a low diffusion rate through the bladder. The gas is supplemented by ambient air diffusing through the bladder to thereby increase the pressure therein and obtain a pressure that remains at or above its initial value over a period of years. (U.S. Patent Nos. 4,340,626, 4,936,029 and 5,042,176 to Marion F. Rudy describe various diffusion mechanisms).

[05] The pressurized, inflatable bladder insert is incorporated into the insole structure, in the '156 patent, by placement within a cavity below the upper, e.g., on top of a midsole layer and within sides of the upper or midsole. In the '945 patent, the inflatable bladder insert is encapsulated within a yieldable foam material, which functions as a bridging moderator filling in the irregularities of the bladder, providing a substantially smooth and contoured surface for supporting the foot and forming an easily handled structure for attachment to an upper. The presence of the moderating foam, however, detracts from the cushioning and perception benefits of the gas inflated bladder. Thus, when the inflated bladder is encapsulated in a foam midsole, the impact response characteristics of the bladder are hampered by the effect of the

foam structure. Referring to FIG. 5 of the '945 patent for example, the cross-section of the midsole shows a series of tubes linked together to form the gas filled bladder. When the bladder is pressurized its tendency is to be generally round in cross-section. The spaces between those bladder portions are filled with foam. Because the foam-filled spaces include such sharp corners, the foam density in the midsole is uneven, i.e., the foam is of higher density in the corners and smaller spaces, and lower density along rounded or flatter areas of the bladder. Since foam has a stiffer response to compression, in the tighter areas with foam concentrations, the foam will dominate the cushioning response upon loading. So instead of a high deflection response, the response can be stiff due to the foam reaction. The cushioning effects of the bladder thus may be reduced due to the uneven concentrations of foam. In addition, the manufacturing techniques used to produce the sole structure formed by the combination of the foam midsole and inflated bladder must also be accommodating to both elements. For example, when encapsulating the inflatable bladder, only foams with relatively low processing temperatures can be used due to the susceptibility of the bladder to deform at high temperatures. The inflated bladder must also be designed with a thickness less than that of the midsole layer in order to allow for the presence of the foam encapsulating material completely therearound. Thus, there are manufacturing as well as performance constraints imposed in the foam encapsulation of an inflatable bladder.

- [06] A cushioning shoe sole component that includes a structure for adjusting the impact response of the component is disclosed in U.S. Patent Nos. 4,817,304 to Mark G. Parker et al. The sole component of Parker et al. is a viscoelastic unit formed of a gas containing bladder and an elastomeric yieldable outer member encapsulating the bladder. The impact resistance of the viscoelastic unit is adjusted by forming a gap in the outer member at a predetermined area where it is desired to have the bladder predominate the impact response. The use of the gap provides an adjustment of the impact response, but the adjustment is localized to the area of the gap. The '304 patent does not disclose a way of tuning the impact response to optimize the response

50879-3

over the time of footstrike through the appropriate structuring of both the bladder and encapsulating material.

- [07] A cushioning system for a shoe sole which uses a bladder connected only along its perimeter and supported in an opening in resilient foam material, is disclosed in U.S. Patent No. 5,685,090 to Tawney et al. The bladder of Tawney et al. has generally curved upper and lower major surfaces and a sidewall that extends outward from each major surface. The angled sidewalls form a horizontally orientated V-shape in cross-section, which fits into a correspondingly shaped groove in the opening in the surrounding resilient foam material. Portions of the top and bottom of the bladder are not covered with the foam material. By forming the bladder without internal connections between the top and bottom surfaces, and exposing portions of the top and bottom surfaces, the feel of the bladder is maximized. However, the '090 patent does not disclose a way of tuning the impact response through design of both the bladder and foam material.
- [08] One type of prior art construction concerns air bladders employing an open-celled foam core as disclosed in U.S. Patent Nos. 4,874,640 and 5,235,715 to Donzis. These cushioning elements do provide latitude in their design in that the open-celled foam cores allow for a variety of shapes of the bladder. However, bladders with foam core tensile members have the disadvantage of unreliable bonding of the core to the barrier layers. One of the main disadvantages of this construction is that the foam core defines the shape of the bladder and thus must necessarily function as a cushioning member at footstrike which detracts from the superior cushioning properties of air alone. The reason for this is that in order to withstand the high inflation pressures associated with such air bladders, the foam core must be of a high strength which requires the use of a higher density foam. The higher the density of the foam, the less the amount of available air space in the air bladder. Consequently, the reduction in the amount of air in the bladder decreases the benefits of cushioning. Cushioning generally is improved when the cushioning component, for a given impact, spreads the

50879-3

impact force over a longer period of time, resulting in a smaller impact force being transmitted to the wearer's body.

- [09] Even if a lower density foam is used, a significant amount of available air space is sacrificed which means that the deflection height of the bladder is reduced due to the presence of the foam, thus accelerating the effect of "bottoming-out." Bottoming-out refers to the failure of a cushioning device to adequately decelerate an impact load. Most cushioning devices used in footwear are non-linear compression based systems, increasing in stiffness as they are loaded. Bottom-out is the point where the cushioning system is unable to compress any further. Compression-set refers to the permanent compression of foam after repeated loads which greatly diminishes its cushioning properties. In foam core bladders, compression set occurs due to the internal breakdown of cell walls under heavy cyclic compression loads such as walking or running. The walls of individual cells constituting the foam structure abrade and tear as they move against one another and fail. The breakdown of the foam exposes the wearer to greater shock forces, and in the extreme, to formation of an aneurysm or bump in the bladder under the foot of the wearer, which will cause pain to the wearer.
- [10] Another type of composite construction prior art concerns air bladders which employ three dimensional fabric as tensile members such as those disclosed in U.S. Patent Nos. 4,906,502, 5,083,361 and 5,543,194 to Rudy; and U.S. Patent Nos. 5,993,585 and 6,119,371 to Goodwin et al. The bladders described in the Rudy patents have enjoyed commercial success in NIKE*, Inc. brand footwear under the name Tensile-Air®. Bladders using fabric tensile members virtually eliminate deep peaks and valleys. In addition, the individual tensile fibers are small and deflect easily under load so that the fabric does not interfere with the cushioning properties of air.
- [11] One shortcoming of these bladders is that currently there is no known manufacturing method for making complex-curved, contoured shaped bladders using these fabric

*Trade-mark

fiber tensile members. The bladders may have different levels, but the top and bottom surfaces remain flat with no contours and curves.

- [12] Another disadvantage is the possibility of bottoming-out. Although the fabric fibers easily deflect under load and are individually quite small, the sheer number of them necessary to maintain the shape of the bladder means that under high loads, a significant amount of the total deflection capability of the air bladder is reduced by the volume of fibers inside the bladder and the bladder can bottom-out.
- [13] One of the primary problems experienced with the fabric fibers is that these bladders are initially stiffer during initial loading than conventional air bladders. This results in a firmer feel at low impact loads and a stiffer "point of purchase" feel that belies their actual cushioning ability. The reason for this is because the fabric fibers have a relatively low elongation to properly hold the shape of the bladder in tension, so that the cumulative effect of thousands of these relatively inelastic fibers is a stiff feel. The tension of the outer surface caused by the low elongation or inelastic properties of the tensile member results in initial greater stiffness in the air bladder until the tension in the fibers is broken and the effect of the air in the bladder can come into play.
- [14] Another category of prior art concerns air bladders which are injection molded, blow-molded or vacuum-molded such as those disclosed in U.S. Patent No. 4,670,995 to Huang; U.S. Patent No. 4,845,861 to Moundjian; U.S. Patent Nos. 6,098,313, 5,572,804, and 5,976,541 to Skaja et al.; and U.S. Patent No. 6,029,962 to Shorten et al. These manufacturing techniques can produce bladders of any desired contour and shape including complex shapes. A drawback of these air bladders can be the formation of stiff, vertically aligned columns of elastomeric material which form interior columns and interfere with the cushioning benefits of the air. Since these interior columns are formed or molded in the vertical position and within the outline of the bladder, there is significant resistance to compression upon loading which can severely impede the cushioning properties of the air.

- [15] Huang '995 teaches forming strong vertical columns so that they form a substantially rectilinear cavity in cross section. This is intended to give substantial vertical support to the air cushion so that the vertical columns of the air cushion can substantially support the weight of the wearer with no inflation (see '995, Column 5, lines 4-11). Huang '995 also teaches the formation of circular columns using blow-molding. In this prior art method, two symmetrical rod-like protrusions of the same width, shape and length extend from the two opposite mold halves to meet in the middle and thus form a thin web in the center of a circular column (see Column 4, lines 47-52, and depressions 21 in Figs. 1-4, 10 and 17). These columns are formed of a wall thickness and dimension sufficient to substantially support the weight of a wearer in the uninflated condition. Further, no means are provided to cause the columns to flex in a predetermined fashion, which would reduce fatigue failures. Huang's columns 42 can be prone to fatigue failure due to compression loads, which force the columns to buckle and fold unpredictably. Under cyclic compression loads, the buckling can lead to fatigue failure of the columns.
- [16] Prior art cushioning systems which incorporate an air bag or bladder can be classified into two broad categories: cushioning systems which focused on the design of the bladder and its response characteristics; and cushioning systems which focused on the design of the supporting mechanical structure in and around the bladder.
- [17] The systems that focused on the air bladder itself dealt with the cushioning properties afforded by the pneumatics of the sealed, pressurized bladder. The pneumatic response is a desirable one because of the large deflections upon loading which corresponds to a softer, more cushioned feel, and a smooth transition to the bottom-out point. Potential drawbacks of a largely pneumatic system may include poor control of stiffness through compression and instability. Control of stiffness refers to the fact that a solely pneumatic system will exhibit the same stiffness function upon loading. There is no way to control the stiffness response. Instability refers to potential uneven loading and potential shear stresses due to the lack of structural constraints on the bladder upon loading.

50879-3

- [18] Pneumatic systems also focused on the configuration of chambers within the bladder and the interconnection of the chambers to effect a desired response. Some bladders have become fairly complex and specialized for certain activities and placements in the midsole. The amount of variation in bladder configurations and their placement have required stocking of dozens of different bladders in the manufacturing process. Having to manufacture different bladders for different models of shoes adds to cost both in terms of manufacture and waste.
- [19] Certain prior pneumatic systems generally used air or gas in the bladder at pressures substantially above ambient. To achieve and maintain pressurization, it has been necessary to employ specially designed, high-cost barrier materials to form the bladders, and to select the appropriate gas depending on the barrier material to minimize the migration of gas through the barrier. This has required the use of specialty films and gases such as nitrogen or sulfur hexafluoride at high pressures within the bladders. Part and parcel of high pressure bladders filled with gases other than air or nitrogen is added requirement to protect the bladders in the design of the midsole to prevent rupture or puncture.
- [20] The prior art systems which focused on the mechanical structure by devising various foam shapes, columns, springs, etc., dealt with adjusting the properties of the foam's response to loading. Foam provides a cushioning response to loading in which the stiffness function can be controlled throughout and is very stable. However, foam, even with special construction techniques, does not provide the large deflection upon loading that pneumatic systems can deliver.

50879-3

SUMMARY OF THE INVENTION

In one aspect of the present invention, there is provided a sole component for forming a portion of an article of footwear, the sole component comprising: a
5 midsole formed from a polymer foam material, the midsole defining a void; and a sealed chamber at least partially positioned within the void, the chamber having a first surface, an opposite second surface, and a sidewall surface extending between a perimeter of the first surface and a
10 perimeter of the second surface, the first surface having a pair of rounded end areas, one of the rounded end areas being larger than another of the rounded end areas, and the first surface having a greater area than the second surface such that the sidewall surface tapers between the first
15 surface and the second surface entirely around the chamber, the second surface having at least fifty percent lesser area than the first surface, the chamber being devoid of internal connections that extend between the first surface and the second surface.

20 In another aspect of the present invention, there is provided a sole component for an article of footwear, the sole component including a midsole and a sealed chamber at least partially encapsulated within the midsole, the chamber comprising: a first surface having a first perimeter with a
25 pear shape, at least a portion of the first surface being substantially planar; a second surface spaced from the first surface, the second surface having a second perimeter with a pear shape, at least a portion of the second surface being substantially planar, and the second surface having at least
30 fifty percent lesser area than the first surface; and a sidewall surface extending between the first perimeter and the second perimeter of the second surface, the sidewall surface tapering inward between the first surface and the

50879-3

second surface, wherein the chamber is devoid of internal connections that extend between the first surface and the second surface, and the chamber is positioned within the midsole such that the first surface is substantially
5 coplanar with a surface of the midsole.

In another aspect of the present invention, there is provided a sole component for forming a portion of an article of footwear, the sole component comprising: a midsole formed from a polymer foam material, the midsole
10 having an upper surface and an opposite lower surface, and the midsole defining a void; a chamber at least partially positioned within the void, the chamber having a first surface, an opposite second surface, and a sidewall surface extending between a perimeter of the first surface and a
15 perimeter of the second surface, the first surface having an area that is at least two times an area of the second surface such that the sidewall surface tapers between the first surface and the second surface, the chamber being devoid of internal connections that extend between the first
20 surface and the second surface; and a fluid sealed within the chamber, the fluid having a fluid pressure between zero and five pounds per square inch, wherein the chamber is oriented within the midsole such that the first surface is substantially coplanar with the upper surface of the midsole
25 and exposed on the upper surface.

[21] An embodiment of the present invention pertains to a sole component for footwear incorporating a sealed, fluid containing chamber and resilient material to harness the benefits of both a pneumatic system and a mechanical system,
30 i.e., provide a large deflection at high impact, controlled stiffness response, a smooth transition to maximum deflection and stability. The sole component of the present invention is specifically designed to

optimally combine pneumatic and mechanical structures and properties. The sealed, fluid containing chamber can be made by sealing an appropriately shaped void in the resilient material, or forming a bladder of resilient barrier material.

- [22] Recognizing that resilient material, such as a foamed elastomer, and air systems each possess advantageous properties, the present invention focuses the design of cushioning systems combining the desirable properties of both types, while reducing the effect of their undesirable properties.
- [23] Foamed elastomers as a sole cushioning material possesses a very desirable material property: progressively increasing stiffness. When foamed elastomers are compressed the compression is smooth as its resistance to compression is linear or progressive. That is, as the compression load increases, foamed elastomers become or feel increasingly stiff. The high stiffness allows the foamed elastomers to provide a significant contribution to a cushioning system. The undesirable properties of foamed elastomers include limitations on deflection by foam density, quick compression set, and limited design options.
- [24] Gas filled chambers or bladders also possess very desirable properties such as high deflection at impact and a smooth transition to bottom-out. The soft feel of a gas filled bladder upon loading is the effect of high deflection, which demonstrates the high energy capacity of a pneumatic unit. Some difficulties of designing gas filled bladder systems include instability and the need to control the geometry of the bladder. Pressurized bladders by their very nature tend to take on a shape as close to a ball, or another round cross-section, as possible. Constraining this tendency can require complex manufacturing methods and added elements to the sole unit.
- [25] In the past these two types of structures were used together but were not specifically designed to work together to exhibit the best properties of each system while eliminating or minimizing the drawbacks.

- [26] This is now possible due to the specially designed single chamber, pear-shaped, or taper-shaped bladder that can be used in a variety of locations and configurations in a midsole. The tapered shape has at least one planar major surface and a contoured surface, which is contoured from side to side and front to back. This contoured surface, when used with a resilient material, such as a foamed elastomer, provides a smooth stiffness transition from the resilient material to the bladder and vice-versa. The single chamber tapered bladder can be used in a variety of locations and configurations in a midsole to provide desired response characteristics. Only one bladder shape is required to be stocked which will significantly reduce manufacturing costs.
- [27] The present invention provides the best of pneumatic and mechanical cushioning properties without high pressurization of the air bladder. The air bladder used in the present invention is simply sealed with air at ambient pressure or at a slightly elevated pressure, within 5psi (gauge) of ambient, and does not require nitrogen or specialized gases. Since the bladder is pressurized to a very low pressure if at all, the air bladder of the present invention also does not require a special barrier material. Any available barrier material can be used to make the bladder, including recycled materials which presents another substantial cost advantage over conventional pressurized bladders. Against the prevailing norm of pressurization, the cushioning system of the present invention is engineered to provide sufficient cushioning with an air bladder sealed at ambient pressure.
- [28] The single chamber air bladder of the present invention can be formed by blow-molding or vacuum forming with the bladder sealed from ambient air at ambient pressure or at slightly elevated pressure. Because high pressurization is not required, the additional manufacturing steps of pressurizing and sealing a pressurized chamber are not required. Minimizing complexity in this way will also be less expensive resulting in a very cost-effective system that provides all of the benefits of more expensive specially designed pneumatic systems.

[29] When a cushioning system is loaded, the desired response is one of large deflection at initial load or strike to absorb the shock of the greatest force, and a progressively increasing stiffness response to provide stability through the load. The overall stiffness is controlled primarily by the density or hardness of the resilient material – the foam density or hardness when a foamed elastomer is used. Because of the smoothly contoured transition areas of the foam material and air bladder interface, foam densities are even and high concentrations are eliminated. The gentle slopes and contours of the tapered air bladder provide gradual transitions between the foam material and air bladder responses. Thus, because of the shape of the air bladder, the response to a load can be controlled by its placement. Placing the tapered, for example, pear-shaped air bladder at ambient or very low pressure under the area of greatest force of the wearer's foot affords greater deflection capacity than current systems, which employ high pressurization. This is due to the relatively large volume of the tapered air bladder, in combination with the lack of internal connections or structure within the interior area of the bladder, allowing for a relatively large deflection upon load. For example, when the pear shape is used, the larger, more bulbous end of the pear shaped bladder will deflect more than the narrower end. With this parameter in mind, rotation and movement of the air bladder can provide very different cushioning characteristics, which can mimic the effect of more complex and expensive foam structures within a midsole. In this way the air bladder and foam material work in concert to provide the desired response.

[30] These and other features and advantages of the invention may be more completely understood from the following detailed description of the preferred embodiments of the invention with reference to the accompanying drawings.

BRIEF DESCRIPTION OF THE DRAWINGS

[31] FIG. 1 is an exploded perspective view of a footwear sole in accordance with the present invention showing air bladders placed in the heel and metatarsal head areas.

50879-3

- [32] FIG. 2A is a top plan view of the sole of FIG. 1 shown with the air bladders positioned in the foam midsole material.
- [33] FIG. 2B is a top plan view of an alternative embodiment of the footwear sole of FIG. 1 in which an air bladder is rotated in its orientation to provide a specific response.
- [34] FIG. 3A is a cross-section taken along line 3A-3A of FIG. 2A.
- [35] FIG. 3B is a cross-section taken along line 3B-3B of FIG. 2B.
- [36] FIG. 4 is a cross-section taken along line 4-4 of FIG. 2A.
- [37] FIG. 5 is a side elevational view of the heel air bladder shown in the top-load configuration.
- [38] FIG. 6 is an end elevation view of the air bladder of FIG. 5.
- [39] FIG. 7 is a bottom plan view of the air bladder of FIG. 5.
- [40] FIG. 8A is a cross-section taken along line 8A-8A of FIG. 7.
- [41] FIG. 8B is a cross-section similar to that of FIG. 8A and shown with a representation of midsole foam material to illustrate the smooth transition of stiffness during footstrike.
- [42] FIG. 9A is a cross-section taken along line 9A-9A of FIG. 7.
- [43] FIG. 9B is a cross-section similar to that of FIG. 9A and shown with a representation of midsole foam material to illustrate the smooth transition of stiffness during footstrike.
- [44] FIG. 10 is a side elevational view of the calcaneus air bladder shown in the top-load configuration.

- [45] FIG. 11 is an end elevation view of the air bladder of FIG. 10.
- [46] FIG. 12 is a bottom plan view of the air bladder of FIG. 10.
- [47] FIG. 13 is a cross-section taken along line 13-13 of FIG. 12.
- [48] FIG. 14 is a cross-section taken along line 14-14 of FIG. 12.
- [49] FIG. 15 is an exploded assembly view of the cushioning system shown in FIG. 1 with other elements of a shoe assembly.
- [50] FIG. 16A is an exploded perspective view of another embodiment of a heel chamber in accordance with the present invention.
- [51] FIG. 16B is a cross-section taking along line 16B-16B of FIG. 16A, with the heel chamber sealed.
- [52] FIG. 16C is a cross-section taken along line 16C-16C of FIG. 16A, with the heel chamber sealed.
- [53] FIG. 17A is a diagrammatic cross-section of a sealed chamber illustrating film tensioning and internal pressure when no force is applied to the sealed chamber.
- [54] FIG. 17B is a diagrammatic cross-section of a sealed chamber illustrating film tensioning and internal pressure when light force is applied to the sealed chamber.
- [55] FIG. 17C is a diagrammatic cross-section of a sealed chamber illustrating film tensioning and internal pressure when increasing force is applied to the sealed chamber.
- [56] FIG. 17D is a diagrammatic cross-section of a sealed chamber illustrating film tensioning and internal pressure when high force is applied to the sealed chamber.

DETAILED DESCRIPTION OF THE INVENTION

- [57] Sole 10 of the present invention includes a midsole 12 of an elastomer material, preferably a resilient foam material and one or more air bladders 14, 16 disposed in the midsole. FIGS. 1-4 illustrate a cushioning system with a bladder 14 disposed in the heel region and a bladder 16 disposed in the metatarsal head region, the areas of highest load during footstrike. The bladders are used to form sealed chambers of a specific shape. In an alternate embodiment a sealed chamber can be formed from a void in an elastomeric chamber that is sealed with a separate cover material. The shape of the chambers and their arrangement in the elastomeric material, particularly in the heel region, produces the desired cushioning characteristics of large deflection for shock absorption at initial footstrike, then progressively increasing stiffness through the footstrike.
- [58] The preferred shape of the bladder is a contoured taper shaped outline, preferably pear-shaped, as best seen in FIGS. 5-14. This shape was determined by evaluating pressures exerted by the bottom of a wearer's foot. The shape of the air bladder matches the pressure map of the foot, wherein the higher the pressure, the higher the air-to-foam depth ratio. The shape of the outline is defined by the two substantially planar major surfaces in opposition to one another and in generally parallel relation: a first major surface 18 and a second major surface 20. These surfaces each have a perimeter border 22, 24 respectively which define the shape of the bladder so that bladder 14 has a larger rounded end 27 and tapers to a more pointed narrow end 29. Narrow end 29 has a width substantially less than the maximum width of larger rounded end 27 so that major surfaces 18 and 20 take on a generally pear-shaped outline. Second major surface 20 has substantially the same outline as first major surface 18 but is smaller in surface area by approximately 50%. At the rounded end 27 of the bladder, first major surface 18 and second major surface 20 are only slightly offset as seen in FIGS. 7-8. At narrow end 29 of the bladder, the point of second major surface 20 is further apart from the corresponding point of first major surface

18 than at the rounded end. First major surface 18 and second major surface 20 are symmetric about a longitudinal center line 31 of the bladder. These major surfaces are connected together by a contoured sidewall 26, which extends around the entire bladder. Sidewall 26 is preferably integral with first major surface 18 and second major surface 20, and if the bladder is formed of flat sheets, i.e., vacuum molded, a substantial portion of sidewall 26 is formed from the same sheet making up second major surface 20. Even in a blow-molded bladder, the seam is located such that the sidewall appears to be formed on the same side of the seam as the second major surface.

[59] As best seen in FIGS. 7, 8A and 9A, the longitudinal spacing between the rounded end of second major surface 20 and the rounded end of first major surface 18 is less than the longitudinal spacing between the pointed end of second major surface 20 and the pointed end of first major surface 18. This distance is covered in a contoured manner by sidewall 26 as best seen in FIGS. 5-9A so as to provide a long, smoothly sloped contour at the pointed end of the bladder and a shorter, smoothly sloped contour at the rounded end. This results in a bladder that has a substantially flat side where major surface 18 is disposed, and a substantially convex side where major surface 20 is disposed. Bladder 14 has one axis of symmetry, i.e., the longitudinal axis, and is asymmetrical in all other aspects. This seemingly simple, articulated shape of the air bladder provides a multitude of possible variations depending on the desired cushioning response to load. Also as seen in the Figures, the major surfaces are connected to one another only by the sidewalls. The major surfaces are devoid of any internal connections.

[60] As seen in FIGS. 1, 2A-B and 3A-B, the orientation of the bladder in the foam material can be varied to attain differing cushioning properties. Air bladder 14 can be oriented in the resilient foam material with its longitudinal axis generally aligned with the longitudinal axis of the midsole as shown in FIG. 2A, which will provide overall cushioning and lateral support for a wide range of wearers. Alternatively, air bladder 14 can be oriented with its longitudinal axis rotated with respect to the longitudinal

axis, toward the lateral side, of the midsole as shown in FIG. 2B. With the bladder rotated in this manner, more foam material is present in the medial side of the midsole thereby creating a simulated medial post since the foam material will dominate the response to a load in the medial portion and thereby feel stiffer than the response in the lateral side which will be dominated by the air bladder's deflection. More support is provided on the medial side to stabilize the medial side of the sole and inhibit over-pronation during footstrike. By adjusting the orientation of the air bladder in this manner, the response characteristics of the cushioning system can be customized. The orientations shown in FIGS. 2A and 2B are intended to be exemplary, and other orientations are contemplated to be within the scope of the invention.

- [61] Another possible adjustment to the air bladder's orientation is the determination of which side of the air bladder faces upward. When bladder 14 is positioned in resilient foam material 12 in the orientation shown in FIGS. 1 and 3A, the convex side of the bladder is cradled in the foam, and the flat side faces upward and is not covered with foam, thereby providing more cushioning, i.e. greater deflection of the bladder, and a smooth transition from the feel of the bladder to the stiffer feel of the foam upon loading. The orientation of FIG. 3A in which the mostly planar surface of the bladder is loaded, is referred to herein as the top loaded condition.
- [62] It is possible to turn bladder 14 over and orient it in the foam so that the substantially flat side, containing major surface 18, faces downward and the convex side, containing major surface 20, faces upward, FIG. 3B, so that a foam material arch above the bladder takes the load. This orientation is referred to herein as the bottom loaded condition in which a layer of foam material is disposed over the convex side of the bladder. The bottom loaded condition provides a stiffer response than the top loaded condition since more foam material is present between the heel and the bladder to moderate the feel of the bladder's deflection. Additionally, a structural arch is formed. This results in a stronger support for the heel region during footstrike.
- [63] Similarly, air bladder 16 which is illustrated to be in the metatarsal head region of the midsole affords different cushioning properties depending on its orientation. Air

bladder 16 also has a first major surface 28, which is generally planar, and a second major surface 30, which is also generally planar and is smaller in surface area than first surface 28. The second surface has a surface area approximately 25% to 40% of the surface area of the first surface. These surfaces are generally parallel to one another and are defined by first perimeter border 32 and second perimeter border 34 which are connected by a sidewall 36, similar to sidewall 26 of air bladder 14. Because of the relatively small size of second surface 30, sidewall 36 has a relatively flat slope, in other words, when placed in resilient foam material the transition from air bladder to foam response is very gradual with air bladder 16.

- [64] Air bladder 16 is shown placed in the resilient foam midsole in a top loaded configuration, but as with air bladder 14, it could be turned over to provide a different response to load. The orientation of air bladder 16 with its longitudinal axis aligned with the direction of the metatarsal heads of a wearer as shown in FIG. 2A will provide the desired cushioning response for a wide variety of wearers. However, the orientation can be rotated as explained above to achieve customized responses.
- [65] The line FS in FIG. 2A, which will be referred to as footstrike line FS, illustrates the line of maximum pressure applied by the foot of a wearer to a shoe sole during running by a person whose running style begins with footstrike in the lateral heel area (rear foot strikers). The line FS is a straight line generalization of the direction that the line of maximum pressure follows for rearfoot strikers. The actual line of pressure for a given footstrike would not be precisely along straight line FS, but would generally follow line FS. As seen in this Figure, footstrike line FS starts in the lateral heel area, proceeds diagonally forward and towards the medial side as it proceeds through the heel area (pronation), turns in a more forward direction through the forward heel and arch areas, and finally proceeds through the metatarsal, metatarsal head and toe areas, with the foot leaving the ground (toe off) adjacent the area of the second metatarsal head.
- [66] FIGS. 8B and 9B illustrate how the midsole foam material and the shape of bladder 14 accomplishes smooth transition of stiffness as the foot of the wearer proceeds through

50879-3

footstrike in the heel area towards the forefoot. At initial footstrike, the foot contacts the rear lateral heel area where the midsole is formed entirely of foam material (F1) to provide a firm, stable, yet shock-absorbing effect. As footstrike proceeds medially and forwardly, the amount of foam material (F2) underlying the foot gradually decreases and the thickness of bladder 14 gradually increases because of the smooth, sloped contour of sidewall 26 in the lateral side area (BSL). In this area, the effect of the more compliant bladder 14 gradually takes greater effect for shock absorbing and gradually decreasing the stiffness of the midsole, until an area of maximum bladder thickness and minimum foam thickness (F3) is reached. The maximum bladder thickness occurs in the side-to-side center area (BC) of bladder 14, which underlies the calcaneus of the foot. In this manner, maximum deflection of bladder 14, minimum stiffness and maximum shock attenuation is provided under the calcaneus.

[67] As footstrike proceeds medially past center area BC, sidewall 26 has a smooth contour that decreases the thickness of bladder 14 in the medial side area (BSM) of the bladder so that the thickness of the foam (F4) gradually increases to again provide a smooth transition from the more compliant effect of bladder 14 to the more stiff, supportive effect of the foam material. When footstrike reaches the medial side of the front heel area, the full thickness of foam F5 is reached to provide the maximum supportive effect of the foam material. As seen by comparing FIG. 2A to FIG. 2B, the supportive effect of the foam material in the medial heel front area can be maximized by angling the front bladder 14 toward the lateral side as shown in FIG. 2B. Such angling places more foam material, as compared to bladder 14 in FIG. 2A, in the medial front heel area. This orientation is preferred for a shoe designed to restrict over-pronation during running.

[68] A smooth transition from the effect of the bladder to the effect of the foam material also occurs as footstrike proceeds forward from the rear heel area toward the forefoot area. This transition is accomplished in a similar manner to the transition from the lateral to medial direction by smoothly sloping the forward sidewall of bladder 14 in the forward bladder area BF, and by reducing the overall width of bladder 14 as it

extends from its larger rounded end 27 to its more pointed narrow end 29. In this manner, the thickness of bladder 14 gradually decreases and the thickness of the foam material F6 gradually increases until the full thickness of the foam material is reached in front of bladder 14.

- [69] An alternative method of making the cushioning component is to mold the resilient material, such as a foam elastomer, with a void in the shape of the taper shaped bladder and sealing off the void to form a sealed chamber. Any conventional molding technique can be used, such as injection molding, pour molding, or compression molding. Any moldable thermoplastic elastomer can be used, such as ethylene vinyl acetate (EVA) or polyurethane (PU). This alternative method, as well as an alternative configuration for the sealed chamber within the foam material is illustrated in FIGS. 16A, 16B, and 16C. When a foam elastomer is molded with an insert to provide the void, the foam surrounding the insert will flow and form a skin during the molding process. At the conclusion of the molding process the insert is removed, and the opening which allowed removal of the insert is sealed, such as by the attachment of the outsole, a lasting board, or another piece of resilient material, such as a sheet of thermoplastic urethane 19, as illustrated in FIGS. 16A-C. The skin formed from the molding process acts like air bladder material and seals the air in the void, without the need for a separate air bladder. If a closed cell foam material is used, skin formation would not be required. The sealed chamber provides a comparable cushioning effect as having an ambient air filled air bladder surrounded by the foam. This manufacturing method is economical as no air bladder materials are required. Also, the step of forming the separate air bladder is eliminated.
- [70] As seen in FIGS. 16A to 16C, an alternate sealed chamber 14' is configured for use in the heel area of sole 10'. As with bladder 14, sealed chamber 14' has a contoured tapered shape, and is orientated in the heel area to match with the pressure map of the foot, wherein the higher the pressure, the higher the air to foam depth ratio. Sealed chamber 14' has two substantially planar major surfaces in opposition to one another and in a generally parallel relation: a first major surface 18' and a second major

surface 20'. These surfaces each have a perimeter border 22', 24', respectively, which define the shape of the bladder so that bladder 14 has a first rounded end 27' and tapers slightly to a flat end 29'. A contoured sidewall 26' connects the major surfaces between their respective perimeters 22' and 24'.

- [71] Sealed chamber 14' accomplishes smooth stiffness transition from the lateral to medial direction, and from the rear to forward direction in a manner similar to bladder 14. Comparing FIGS. 9B and 16C, it is seen that a slope contour from bottom surface 24' and along sidewalls 26' is similar on both the medial and lateral sides of sealed chamber 14' as with bladder 14. Thus, proceeding from heel strike in the lateral rear area and moving towards the medial rear area, the smooth transition of stiffness described above is accomplished. Since the perimeter borders 22' and 24' do not taper inwardly as much as the perimeter borders of bladder 14, smooth stiffness transition proceeding from the rear of sealed chamber 14' forward is accomplished by varying the slope from bottom surface 20' forward along sidewall 26' in a manner different from bladder 14. As seen in FIG. 16B, the bottom of sealed chamber 14' tapers upwardly at a greater rate in the forward direction, from bottom surface 20' through sidewall 26' than the upward taper of the bottom in bladder 14, as seen in FIG. 8B. The more rapid upward taper compensates for the lack of narrowing of sealed chamber 14', so as to increase the amount of foam material underlying the bladder as foot strike moves in the forward direction in a proper gradual rate.
- [72] Stiffness can be controlled by adjusting the orientation of the air bladders. For instance, placing the air bladders directly under the calcaneus in the top loaded orientation results in less initial stiffness during footstrike and more later stiffness than when the bladder is placed under the calcaneus in the bottom loaded orientation with foam between the calcaneus and the bladder. Overall stiffness response is controlled primarily by material density or hardness. For the top loaded configuration, increasing foam density or hardness increases the latter stiffness. For the bottom load condition, increasing foam density or hardness increases the middle and latter stiffness. The stiffness slope is also determined by volume, with large air bladders

having lower stiffness and therefore more displacement upon loading. This is due to the larger air volume in a single chamber allowing a gradual pressure increase as the bladder volume decreases during compression. Overall stiffness can also be adjusted by varying the size of the larger first major surface 18, 18'. As will be discussed later, as pressure is applied to the bladder or sealed chamber, the exposed major surface 18, 18' undergoes tensioning. If the area of the major surface 18, 18' is increased, the amount of tension the surface undergoes decreases so that stiffness also decreases.

- [73] A preferred foam material to use is a conventional PU foam with a specific gravity or density in the range of 0.32 to 0.40 grams/cm³, preferably 0.36 grams/cm³. Another preferred foam material is conventional EVA with a hardness in the range of 52 to 60 Asker C, preferably 55 Asker C. Alternatively, a solid elastomer, such as urethane or the like, could be used if the solid elastomer is compliant or shaped to be compliant. Another material property relevant to the sole construction is the tensile stress at a given elongation of the elastomeric material (modulus). A preferred range of tensile stress at 50% elongation is between 250 and 1350 psi.
- [74] When bladder 14, or sealed chamber 14', is incorporated in the heel area of a midsole an appropriate amount of shock attenuation is provided when the open internal volume of the chamber is between about 10 cubic centimeters and 65 cubic centimeters. For such bladders, the substantially flat major surfaces 18, 18' could be in the range of about 1,200 mm² to 4,165 mm². For example, when a bladder with a volume of 36 cubic centimeters is used, the pressure ranges from ambient 0 psi to 35 psi when bladder 14 is compressed to 95% of its original volume.
- [75] Another advantage of the sole structure of the present invention is the manner in which bladder 14 accomplishes smooth, progressive stiffening by the combination of film tensioning and pressure ramping. Enhanced shock attenuation is also accomplished by minimizing the structure under the areas of greatest pressure to allow for greater maximum deflection while the bag is progressively stiffening. FIGS. 17A

50879-3

through 17D illustrate the film tensioning and pressure ramping in the chamber devoid of internal connections.

- [76] FIG. 17A diagrammatically illustrates bladder or sealed chamber 14 within an elastomeric material 13. Bladder 14 has a flat primary surface 18 and a secondary major surface 20 with its tapered sides. In FIG. 17A, no pressure is applied to the bladder and the tension T_0 along primary surface 18 is zero. The pressure inside the bladder likewise is ambient and for ease of reference will be indicated as P_0 being zero.
- [77] FIG. 17B diagrammatically illustrates a small amount of force being applied to bladder 16. For example, a person standing at rest and an external force F_1 representing the external force applied by a calcaneus of the heel to bladder 14. As seen in this FIG. 17B, force F_1 causes primary surface 18 to bend downward a certain degree, reducing the volume within bladder 14, and thereby increasing the pressure to a pressure P_1 . The bowing of primary surface 18 also causes tension in primary surface 18 to increase to T_1 . While not illustrated in these diagrams, material 13 also compresses when forces $F-F_3$ are applied. The combination of increasing pressure within bladder 14 and the compression of the foam material 13 by the downward force helps to stabilize the foam material walls.
- [78] FIG. 17C diagrammatically illustrates increasing calcaneal force F_2 being applied to bladder 14, for example during walking. As seen therein, the volume of bladder 16 has been reduced further, thereby increasing the pressure within the bladder to P_2 and the tension along primary surface 18 to T_2 .
- [79] FIG. 17D illustrates maximum calcaneal force F_3 being applied to bladder 14, for example during running. As seen therein, the volume of bladder 14 has been reduced substantially, thereby substantially increasing the pressure within the bladder to P_3 and the tension along primary surface 18 to T_3 . Since the interior area of the bladder is devoid of internal connection filled with foam, the bladder can compress a significant degree, as seen in FIG. 17D, thereby enhancing the ability of the bladder to absorb

shock. While undergoing this deflection, the pressure is ramping up, such as from P_0 (ambient) to P_3 (greater than 30 psi). The increase in pressure in the bladder, together with the increasing stiffness of the foam material along the sides of the bladder, help stabilize the footbed. The desired objective of maximum deflection for shock absorption, in combination with medial to lateral stability is thus attained with the combination of the appropriately shaped bladder at ambient pressure within an elastomeric material.

- [80] Both air bladders 14 and 16, and sealed chamber 14' contain ambient air and are configured to be sealed at ambient pressure or slightly elevated pressure, within 5psi (gauge) of ambient pressure. The low or no pressurization provides sufficient cushioning for even repeated, cyclic loads. Because high pressurization is not required, air bladders 14 and 16 are not material dependent, and correspondingly, there is no requirement for the use of specialized gases such as nitrogen or sulfur hexafluoride, or specialized barrier materials to form the bladders. Avoiding these specialized materials results in significant cost savings as well as economies of manufacture.
- [81] By varying the orientation and placement of the pear-shaped or taper shaped air bladders sealed at ambient pressure or within 5 psi of ambient pressure, it has been found that a variety of customized cushioning responses are attainable.
- [82] The preferred methods of manufacturing the bladders are blow-molding and vacuum forming. Blow-molding is a well-known technique, which is well suited to economically produce large quantities of consistent articles. The tube of elastomeric material is placed in a mold and air is provided through the column to push the material against the mold. Blow-molding produces clean, cosmetically appealing articles with small inconspicuous seams. Many other prior art bladder manufacturing methods require multiple manufacturing steps, components and materials which makes them difficult and costly to produce. Some prior art methods form conspicuously large seams around their perimeters, which can be cosmetically unappealing. Vacuum forming is analogous to blow-molding in that material,

preferably in sheet form, is placed into the mold to take the shape of the mold, however, in addition to introducing air into the mold, air is evacuated out to pull the barrier material to the sides of the mold. Vacuum forming can be done with flat sheets of barrier material which can be more cost effective than obtaining bars, tubes or columns of material typically used in blow molding elastomeric. A conventional thermoplastic urethane can be used to form the bladder. Other suitable materials are thermoplastic elastomers, polyester polyurethane, polyether polyurethane, and the like. Other suitable materials are identified in the '156 and '945 patents.

- [83] The cushioning components of the present invention are shown as they would be assembled in a shoe S in FIG. 15. Cushioning system 10 is generally placed between a liner 38, which is attached to a shoe upper 40, and an outsole 42, which is the ground engaging portion of the shoe.
- [84] From the foregoing detailed description, it will be evident that there are a number of changes, adaptations, and modifications of the present invention that come within the province of those skilled in the art. However, it is intended that all such variations not departing from the spirit of the invention be considered as within the scope thereof as limited solely by the claims appended hereto.

50879-3

CLAIMS:

1. A sole component for forming a portion of an article of footwear, the sole component comprising:
 - a midsole formed from a polymer foam material, the midsole defining a void; and
 - a sealed chamber at least partially positioned within the void, the chamber having a first surface, an opposite second surface, and a sidewall surface extending between a perimeter of the first surface and a perimeter of the second surface, the first surface having a pair of rounded end areas, one of the rounded end areas being larger than another of the rounded end areas, and the first surface having a greater area than the second surface such that the sidewall surface tapers between the first surface and the second surface entirely around the chamber, the second surface having at least fifty percent lesser area than the first surface, the chamber being devoid of internal connections that extend between the first surface and the second surface.
2. The sole component recited in claim 1, wherein the chamber contains a fluid with a substantially ambient fluid pressure.
3. The sole component recited in claim 1, wherein the chamber contains a fluid with a fluid pressure between zero and five pounds per square inch.
4. The sole component recited in claim 1, wherein the void forms a depression in the midsole, and the first surface of the chamber is positioned at an elevation of an upper surface of the midsole.
5. The sole component recited in claim 1, wherein the void forms a depression in the midsole, and the depression has a shape that corresponds with the second surface and the sidewall surface.
6. The sole component recited in claim 1, wherein a substantial portion of the first surface is planar.
7. The sole component recited in claim 1, wherein a substantial portion of the first surface and a substantial portion of the second surface are planar.
8. The sole component recited in claim 7, wherein the substantial portion of the first surface is substantially parallel to the substantial portion of the second surface.
9. The sole component recited in claim 1, wherein the second surface has a pair of rounded end areas, one of the rounded end areas of the second surface is larger than another of the rounded end areas of the second surface.
10. The sole component recited in claim 1, wherein a portion of the first surface is substantially parallel to a portion of the second surface.

50879-3

11. A sole component for an article of footwear, the sole component including a midsole and a sealed chamber at least partially encapsulated within the midsole, the chamber comprising:

- a first surface having a first perimeter with a pear shape, at least a portion of the first surface being substantially planar;
- a second surface spaced from the first surface, the second surface having a second perimeter with a pear shape, at least a portion of the second surface being substantially planar, and the second surface having at least fifty percent lesser area than the first surface; and
- a sidewall surface extending between the first perimeter and the second perimeter of the second surface, the sidewall surface tapering inward between the first surface and the second surface,

wherein the chamber is devoid of internal connections that extend between the first surface and the second surface, and the chamber is positioned within the midsole such that the first surface is substantially coplanar with a surface of the midsole.

12. The sole component recited in claim 11, wherein the chamber contains a fluid with a substantially ambient fluid pressure.

13. The sole component recited in claim 11, wherein the chamber contains a fluid with a fluid pressure between zero and five pounds per square inch.

14. The sole component recited in claim 11, wherein the first surface is substantially parallel to the second surface.

15. The sole component recited in claim 11, wherein the first surface has a pair of rounded end areas, one of the rounded end areas of the first surface being larger than another of the rounded end areas of the first surface to impart the pear shape to the first surface.

16. The sole component recited in claim 11, wherein the midsole is formed from a polymer foam material.

17. The sole component recited in claim 16, wherein the midsole defines a void, and the chamber is at least partially positioned within the void.

18. The sole component recited in claim 17, wherein the void forms a depression in an upper surface of the midsole, and the first surface of the chamber is positioned at an elevation of the upper surface of the midsole.

19. The sole component recited in claim 17, wherein the void forms a depression in the midsole, and the depression has a shape that corresponds with the second surface and the sidewall surface.

50879-3

20. The sole component recited in claim 11, wherein the first surface, the second surface, and the sidewall surface are formed from an elastomeric material.

21. The sole component recited in claim 11, wherein the first surface is formed from a first sheet of elastomeric material, and the second surface and sidewall surface are formed from a second sheet of the elastomeric material, the first sheet being joined to the second sheet at the first perimeter of the first surface.

22. A sole component for forming a portion of an article of footwear, the sole component comprising:

a midsole formed from a polymer foam material, the midsole having an upper surface and an opposite lower surface, and the midsole defining a void;

a chamber at least partially positioned within the void, the chamber having a first surface, an opposite second surface, and a sidewall surface extending between a perimeter of the first surface and a perimeter of the second surface, the first surface having an area that is at least two times an area of the second surface such that the sidewall surface tapers between the first surface and the second surface, the chamber being devoid of internal connections that extend between the first surface and the second surface; and

a fluid sealed within the chamber, the fluid having a fluid pressure between zero and five pounds per square inch,

wherein the chamber is oriented within the midsole such that the first surface is substantially coplanar with the upper surface of the midsole and exposed on the upper surface.

23. The sole component recited in claim 22, wherein the void forms a depression in the midsole, and the first surface of the chamber is positioned at an elevation of the upper surface of the midsole.

24. The sole component recited in claim 22, wherein the void forms a depression in the midsole, and the depression has a shape that corresponds with the second surface and the sidewall surface.

25. The sole component recited in claim 22, wherein a substantial portion of the first surface and a substantial portion of the second surface are planar.

26. The sole component recited in claim 25, wherein the substantial portion of the first surface is substantially parallel to the substantial portion of the second surface.

27. The sole component recited in claim 22, wherein the first surface has a pair of rounded end areas, one of the rounded end areas being larger than another of the rounded end areas.

50879-3

28. The sole component recited in claim 27, wherein the first surface is symmetrical about an axis extending between the rounded end areas and otherwise asymmetrical.

29. The sole component recited in claim 22, wherein at least one of the first surface and the second surface have a pear shape.

30. The sole component recited in claim 22, wherein a portion of the first surface is substantially parallel to a portion of the second surface.

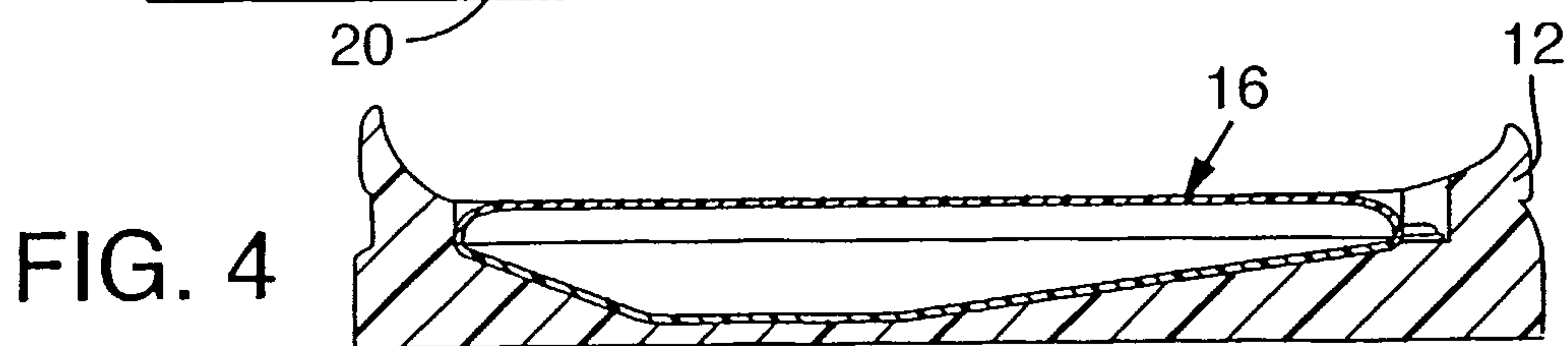
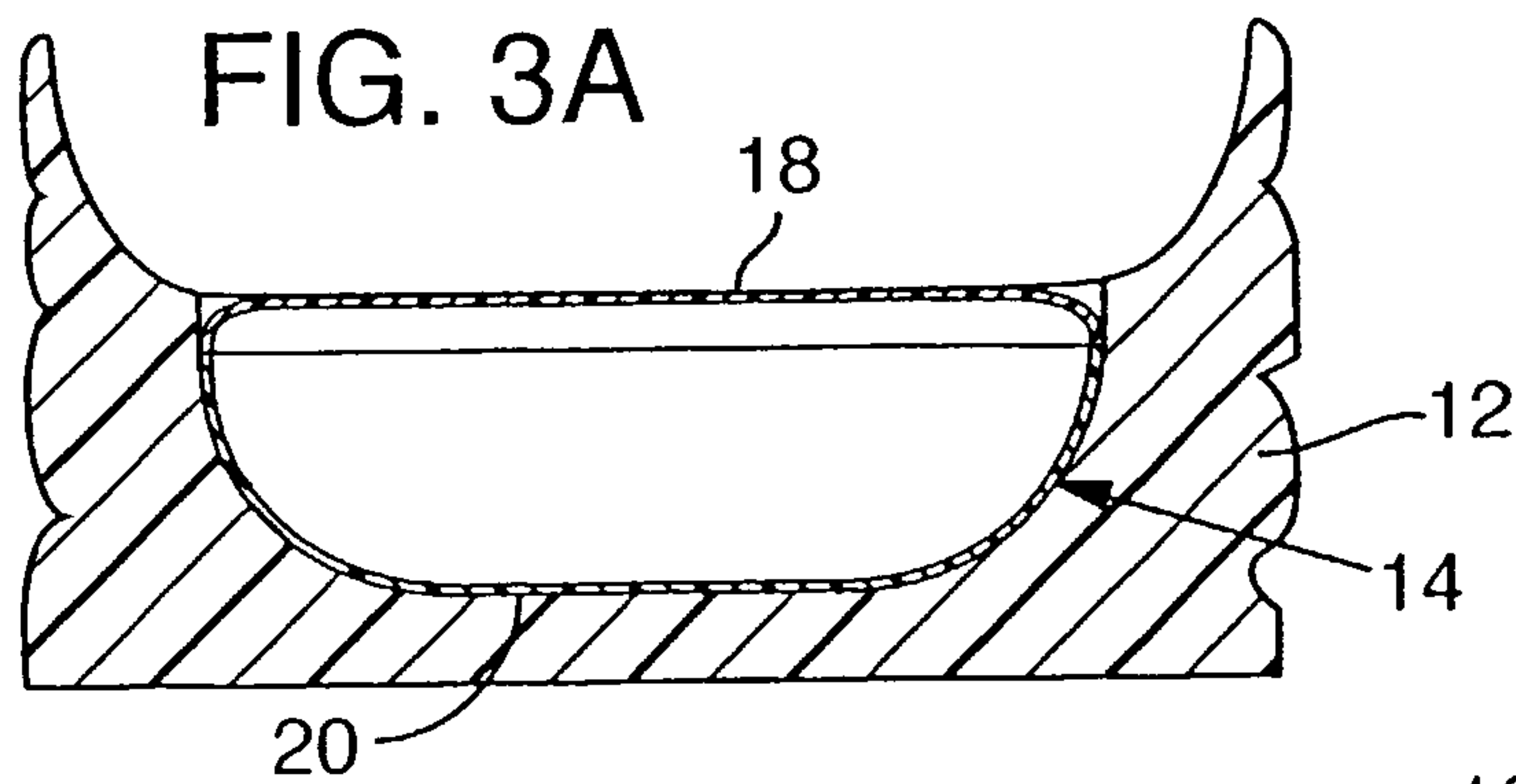
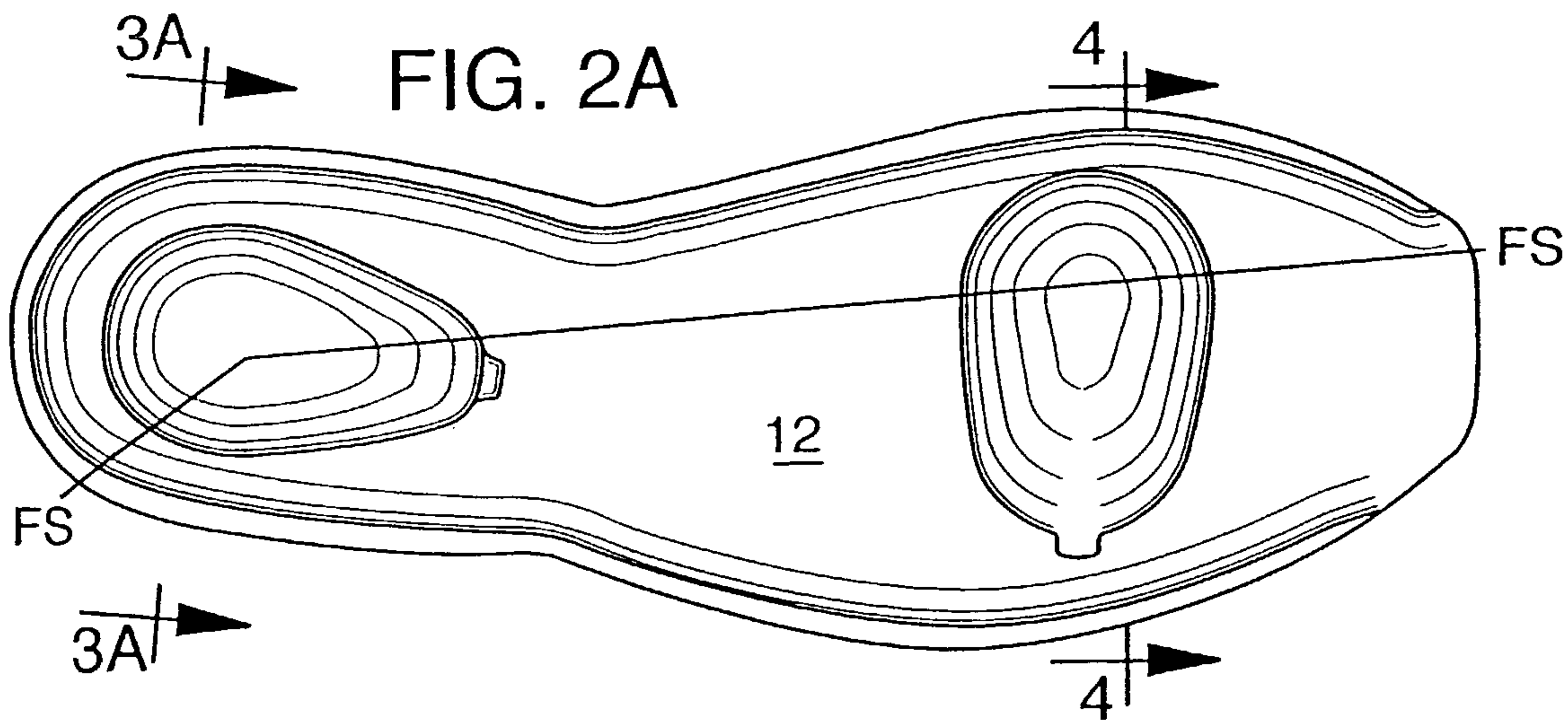
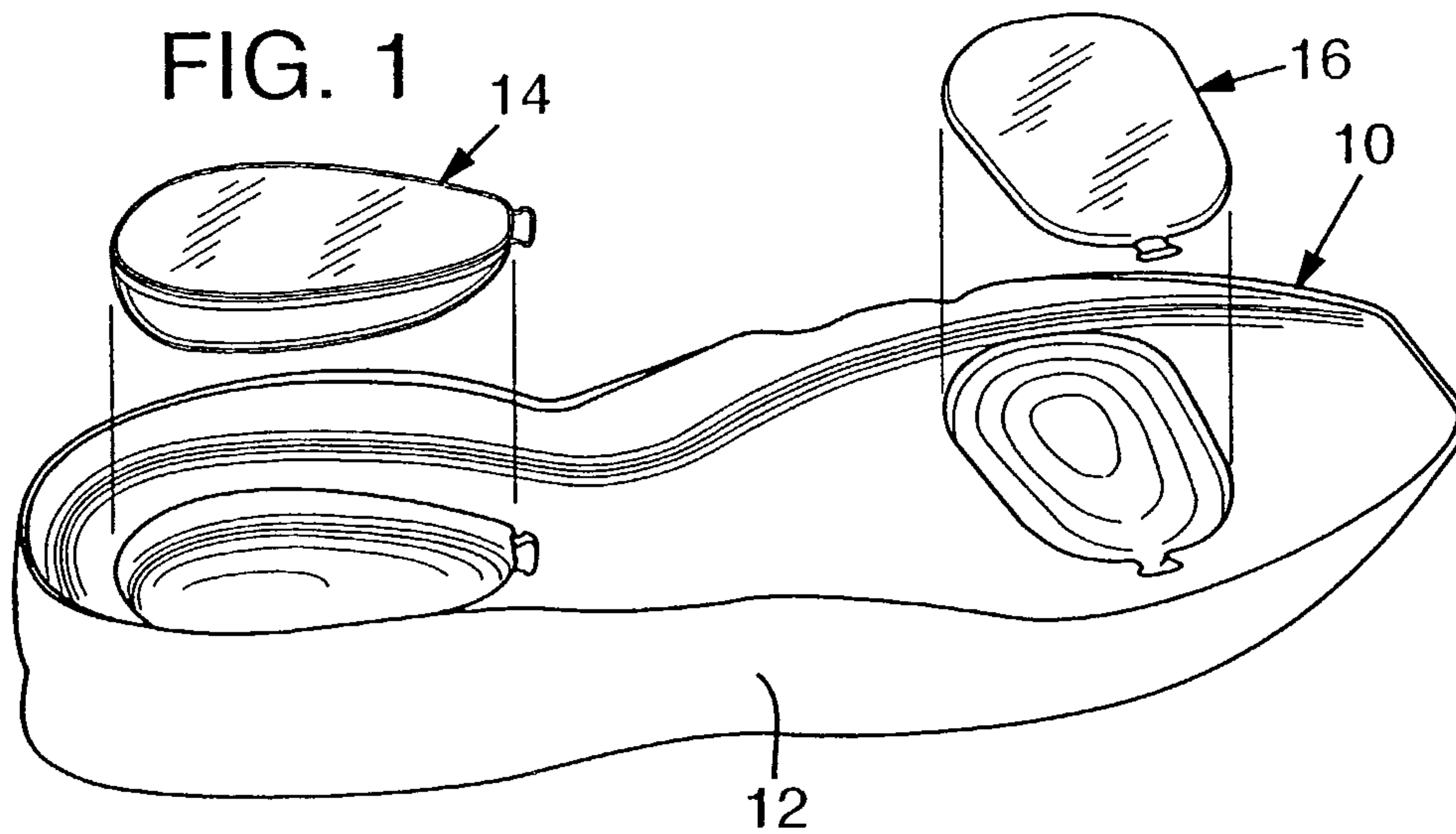

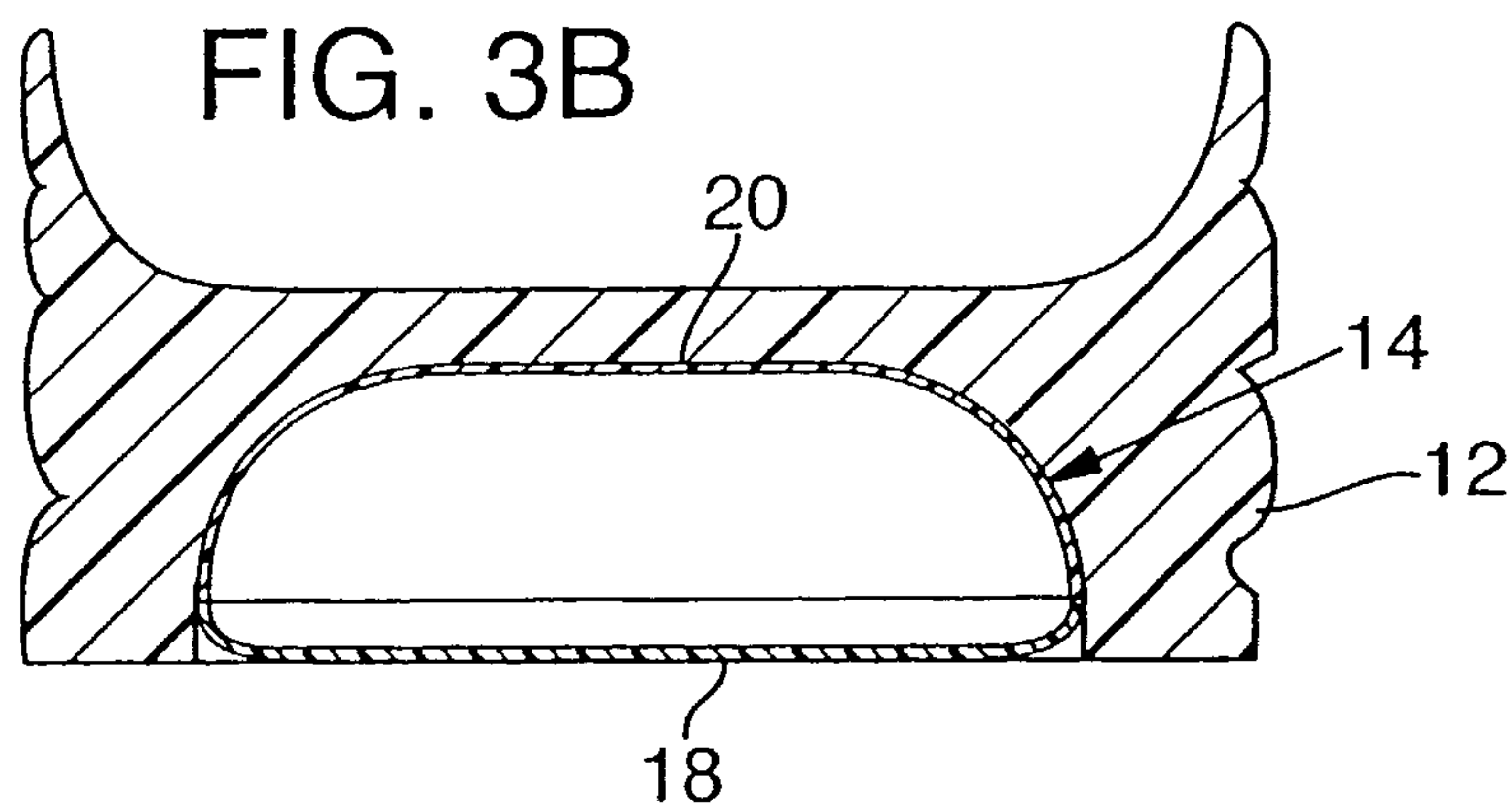
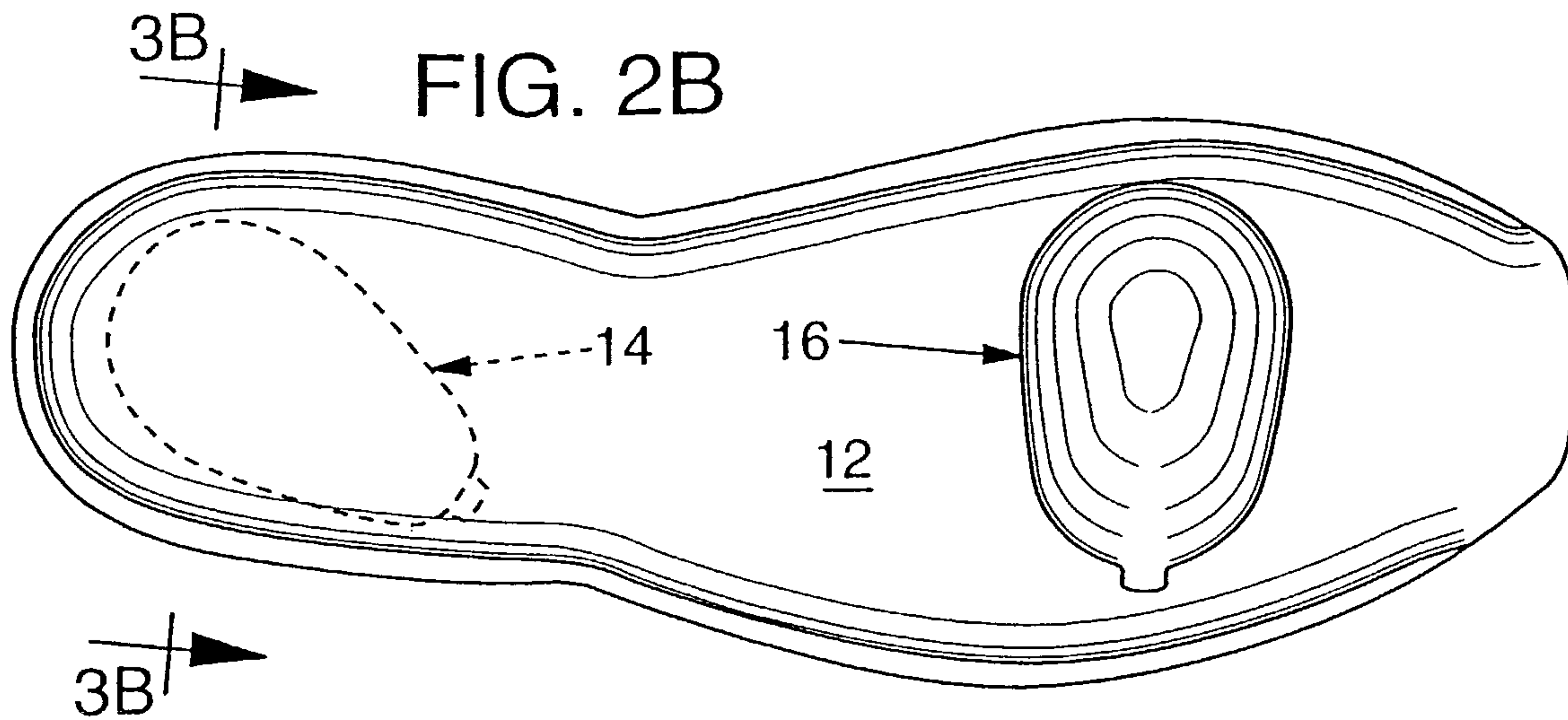

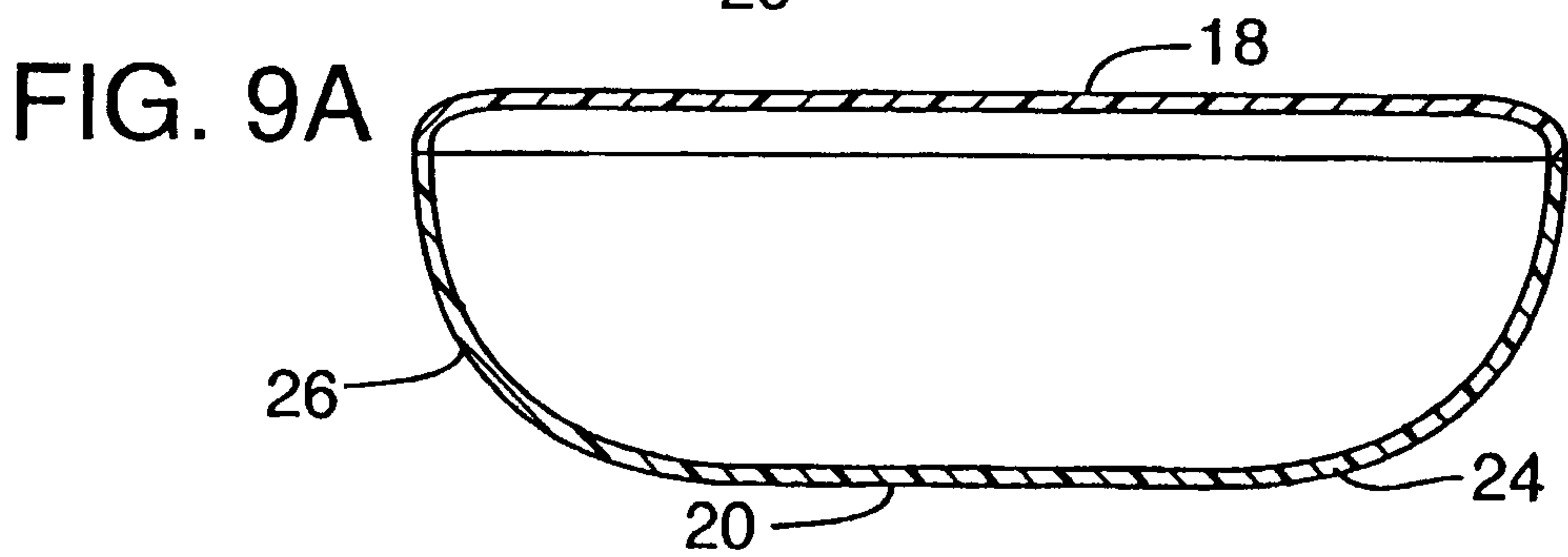
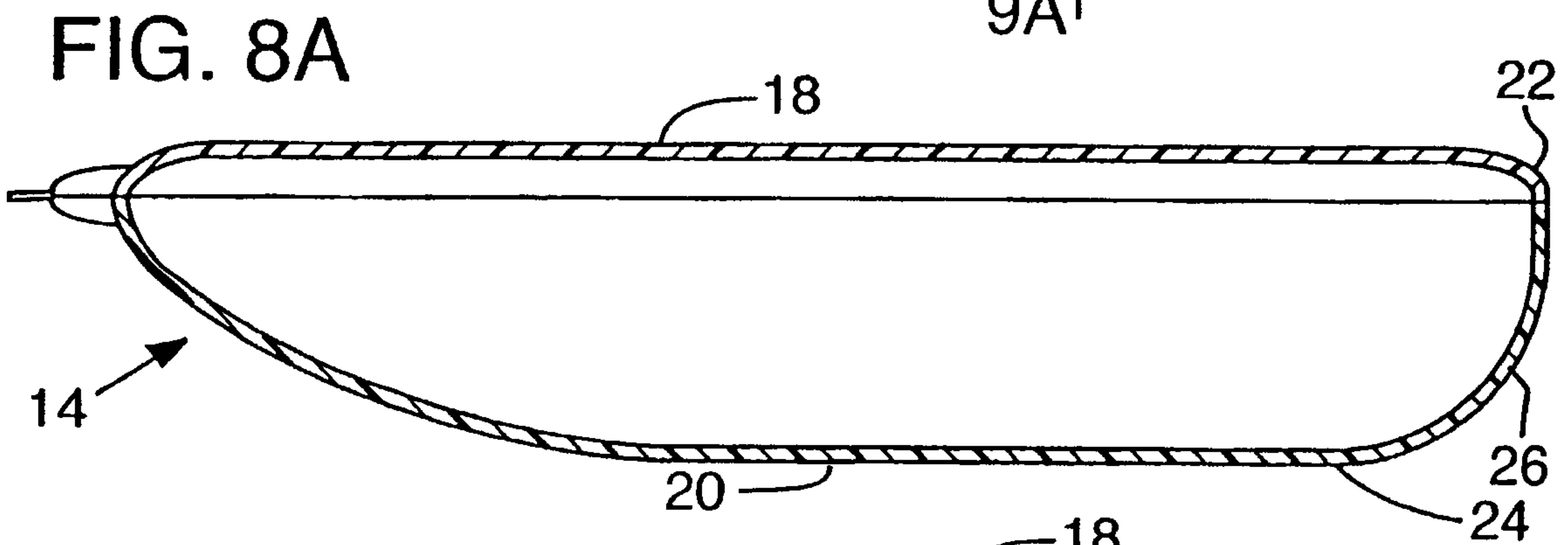
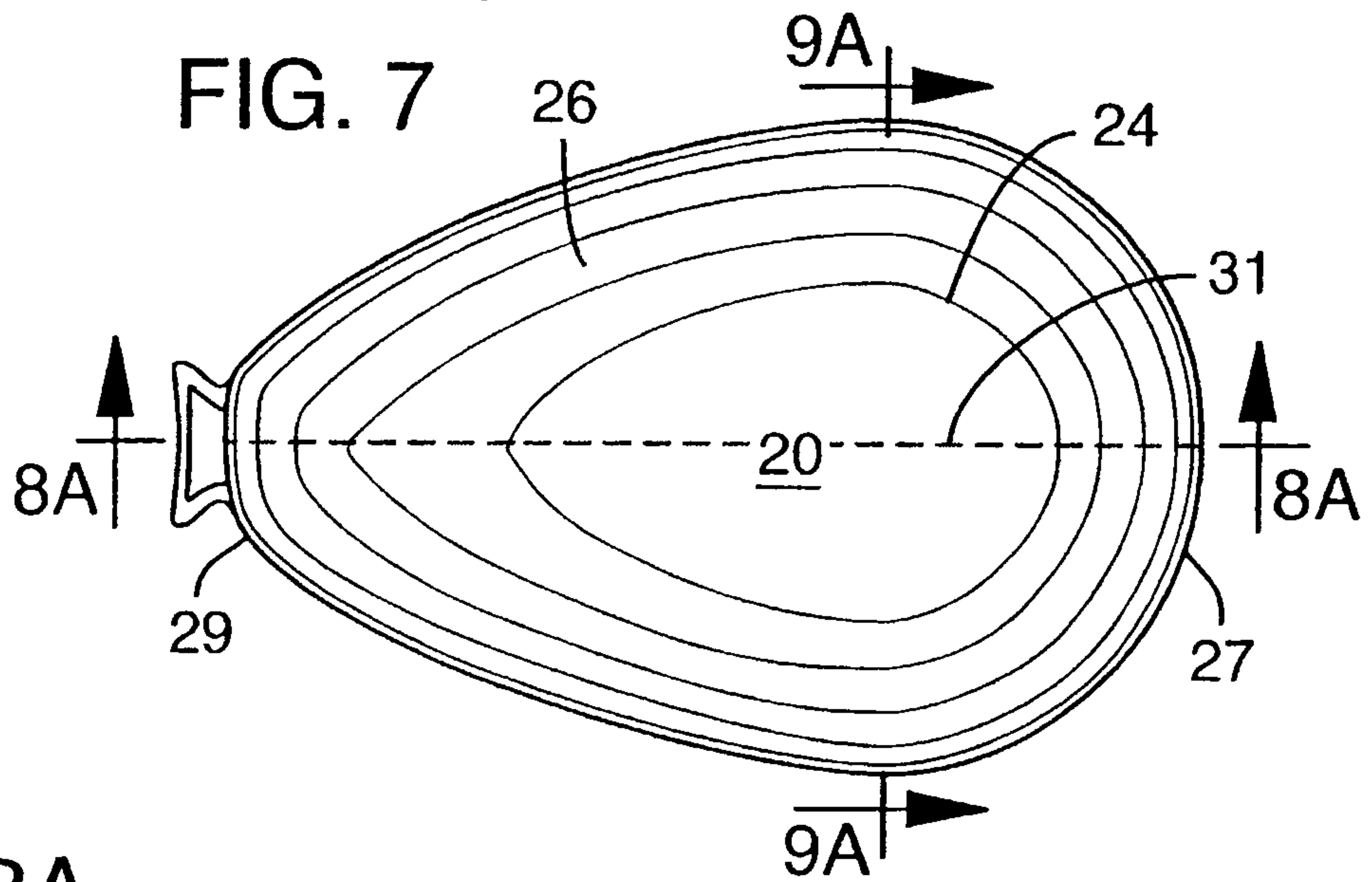
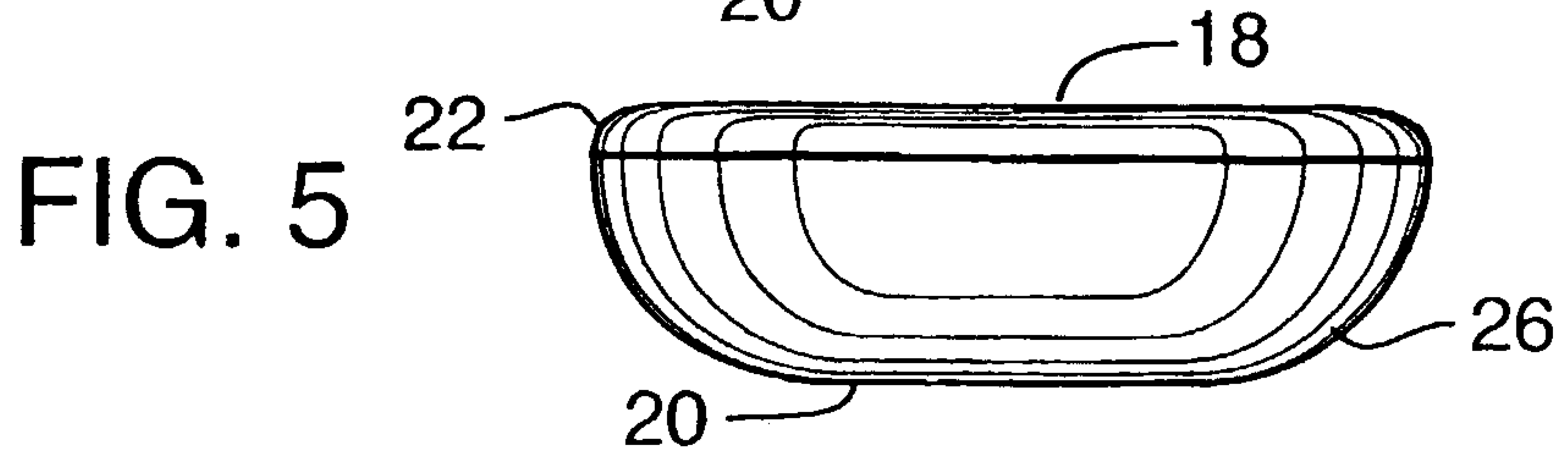
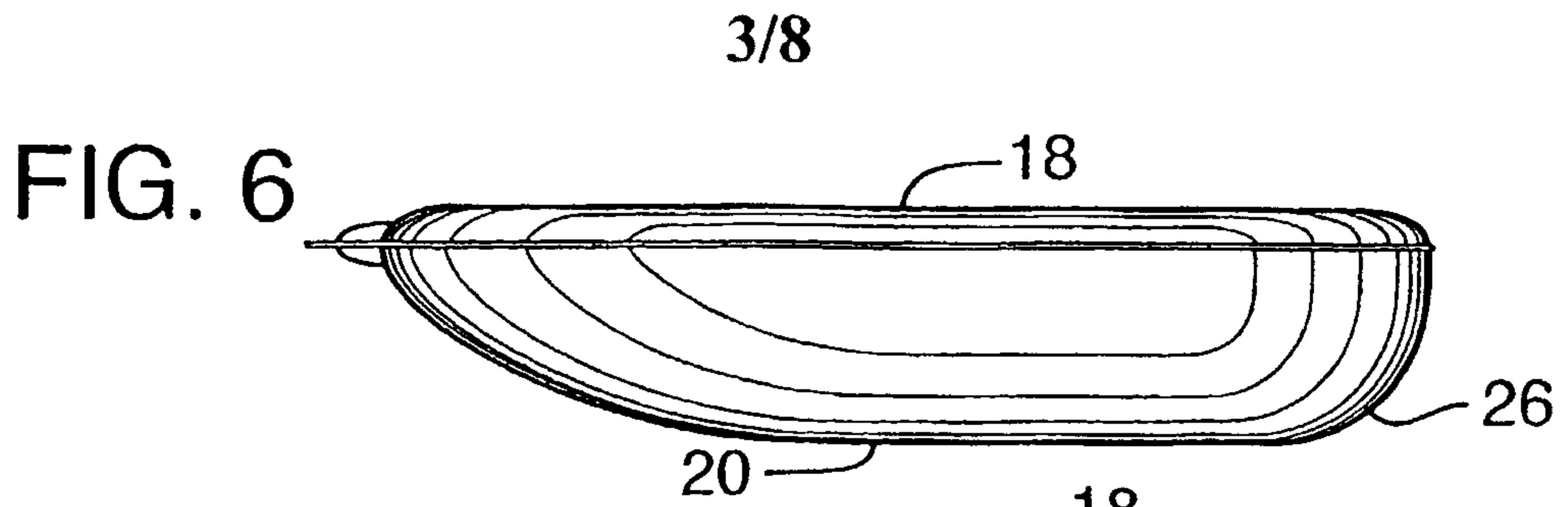

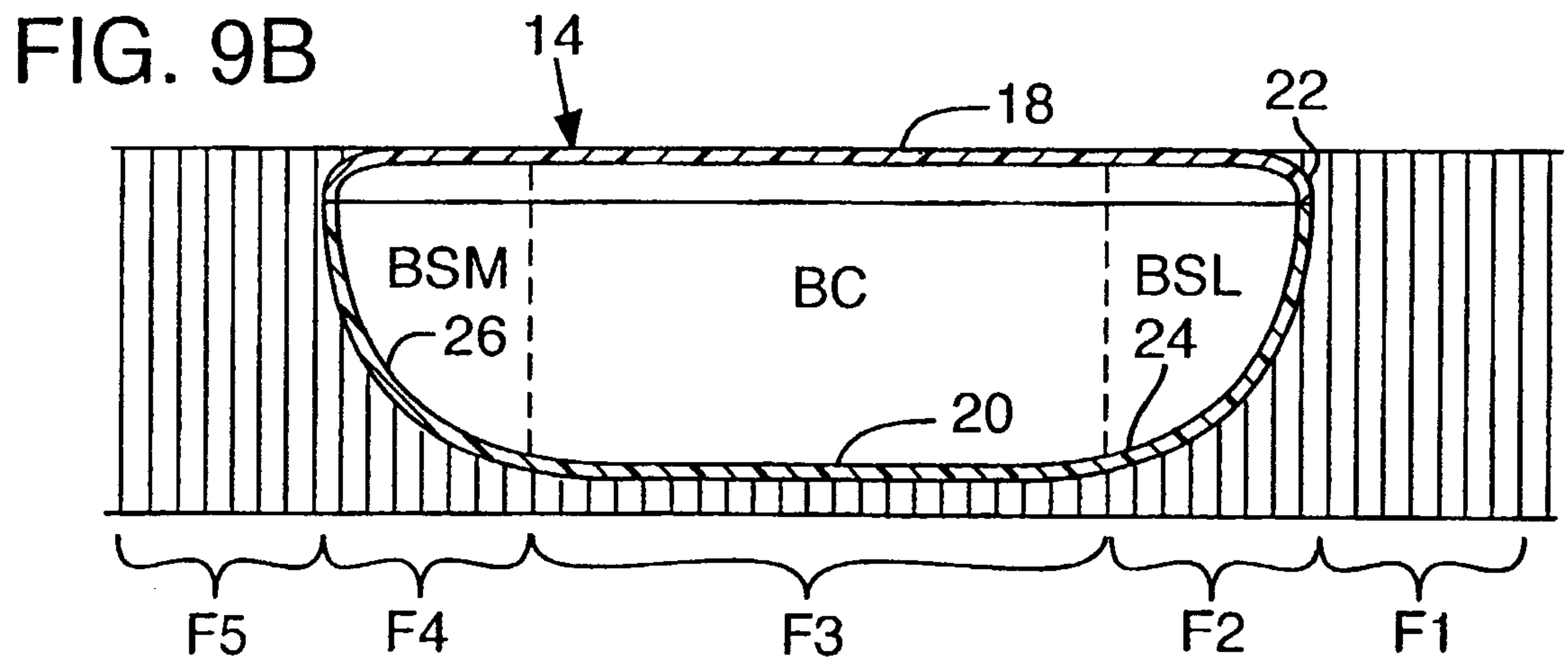
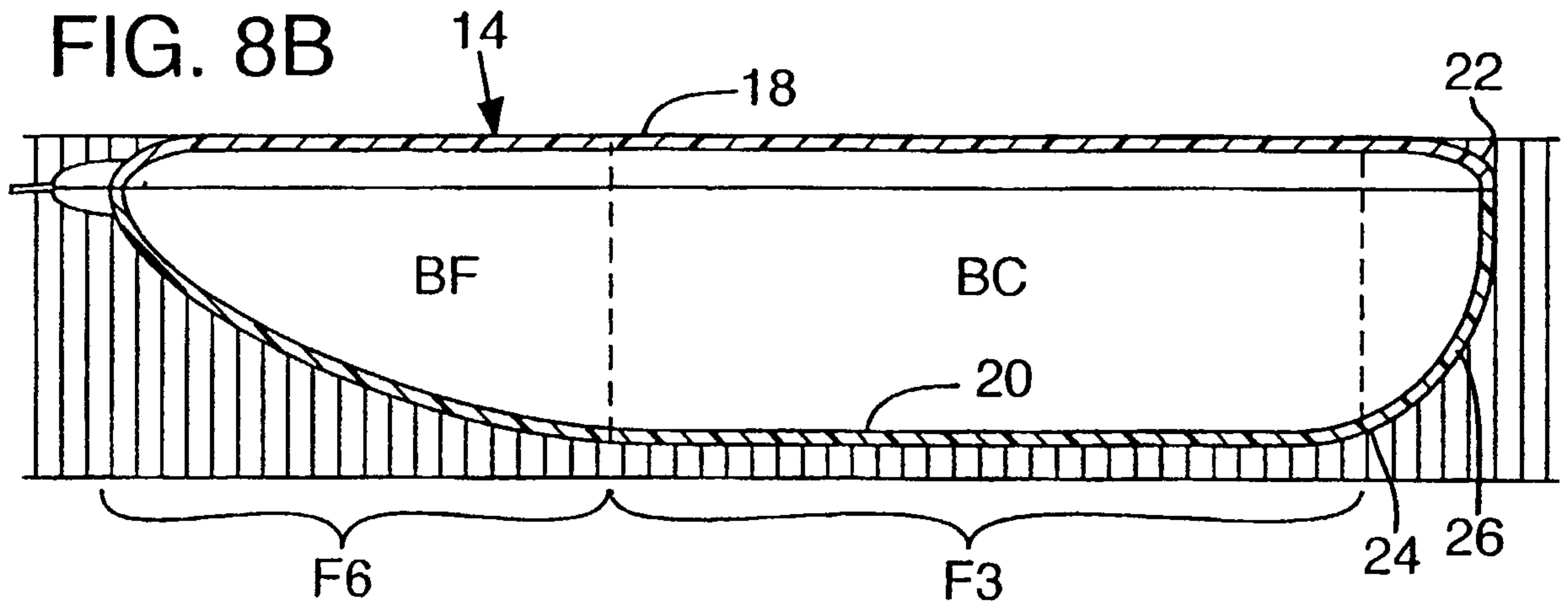

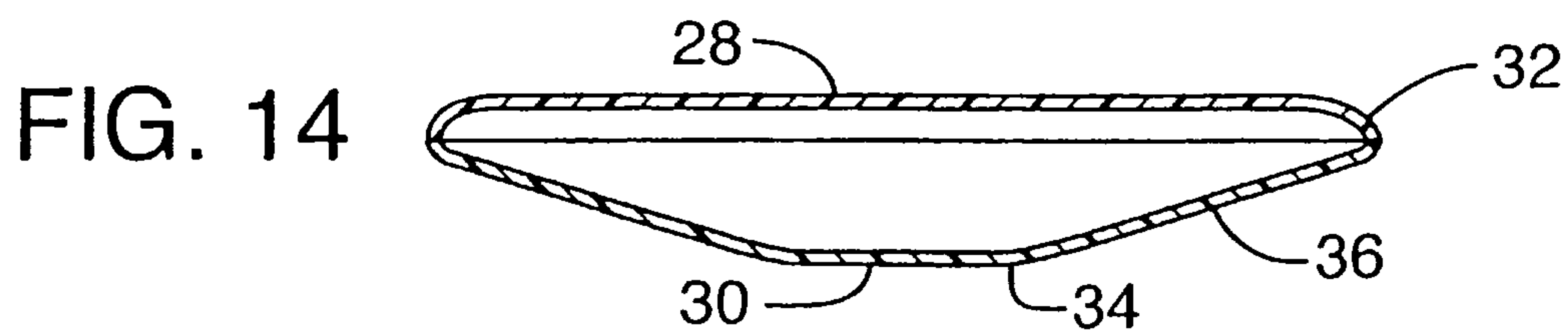
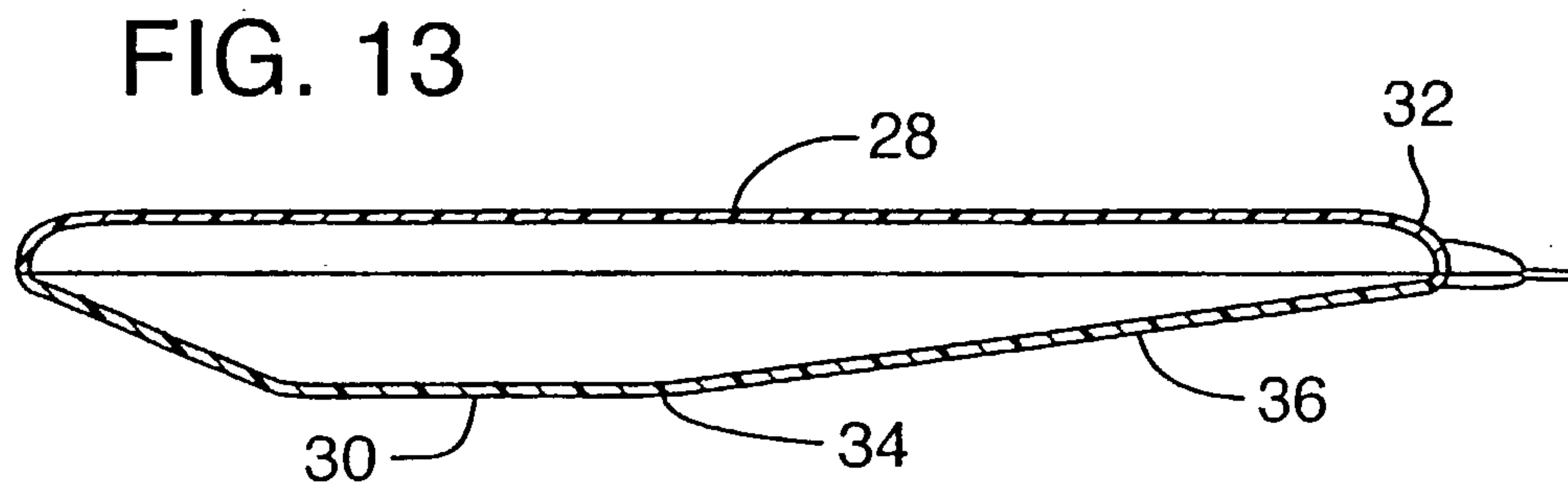
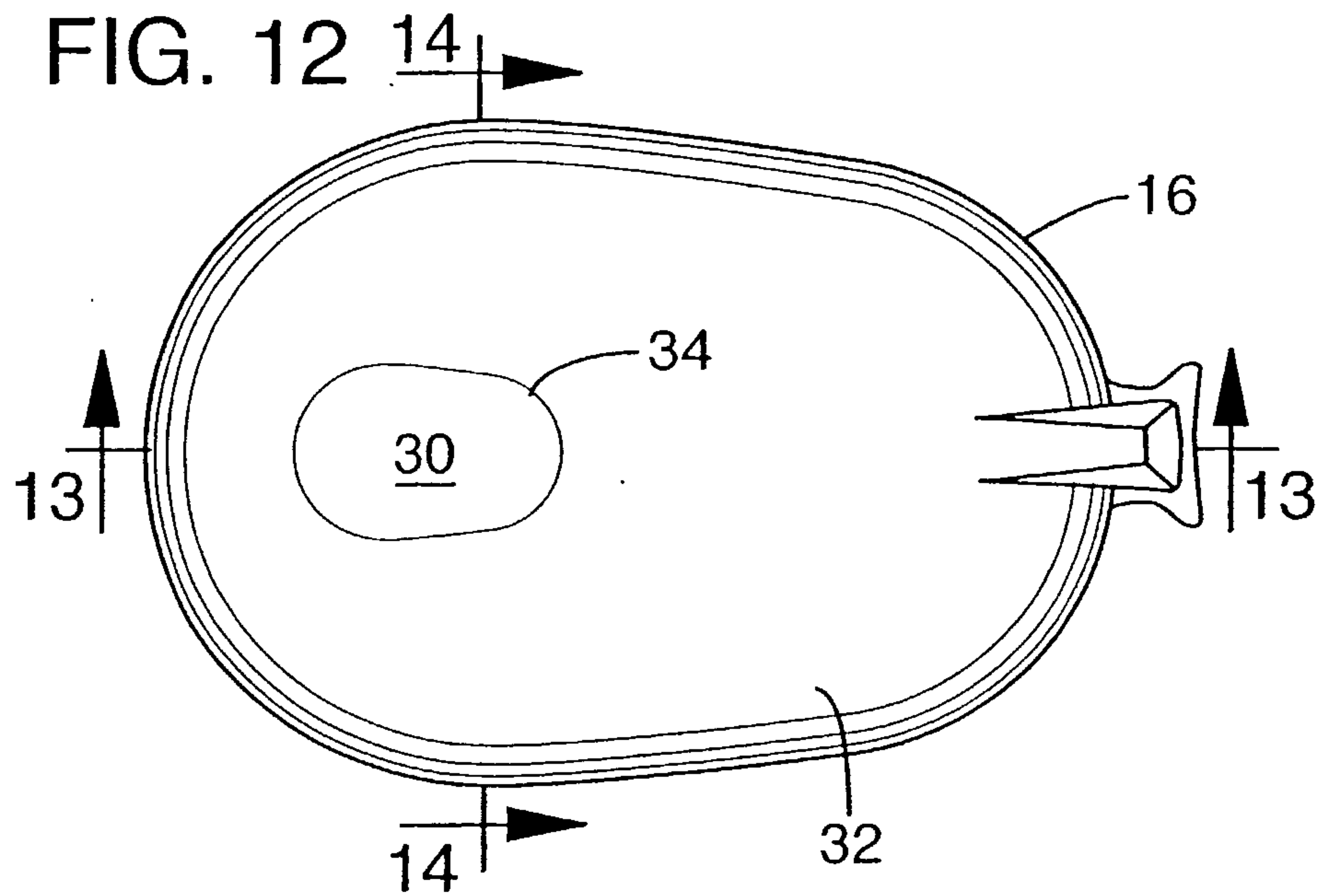
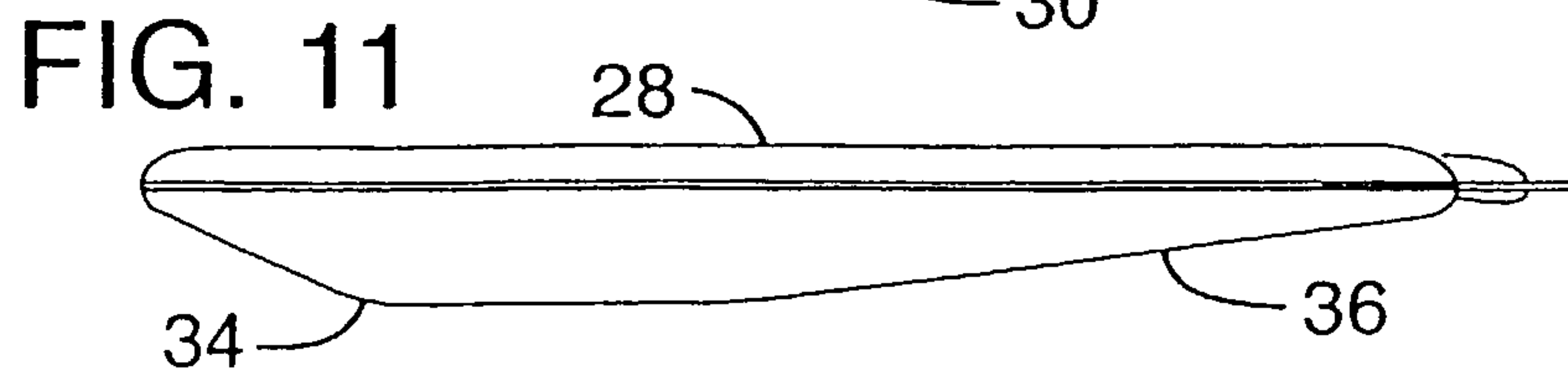
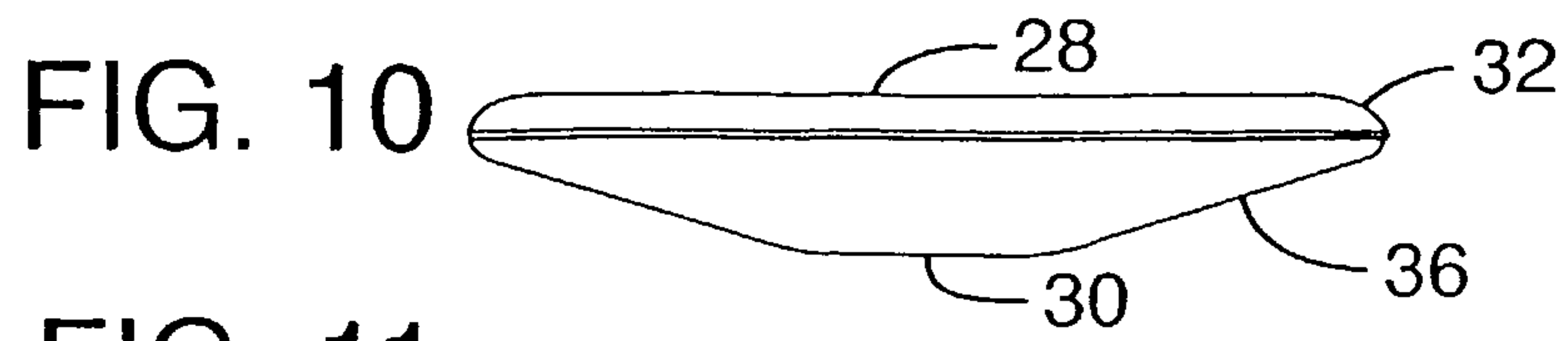

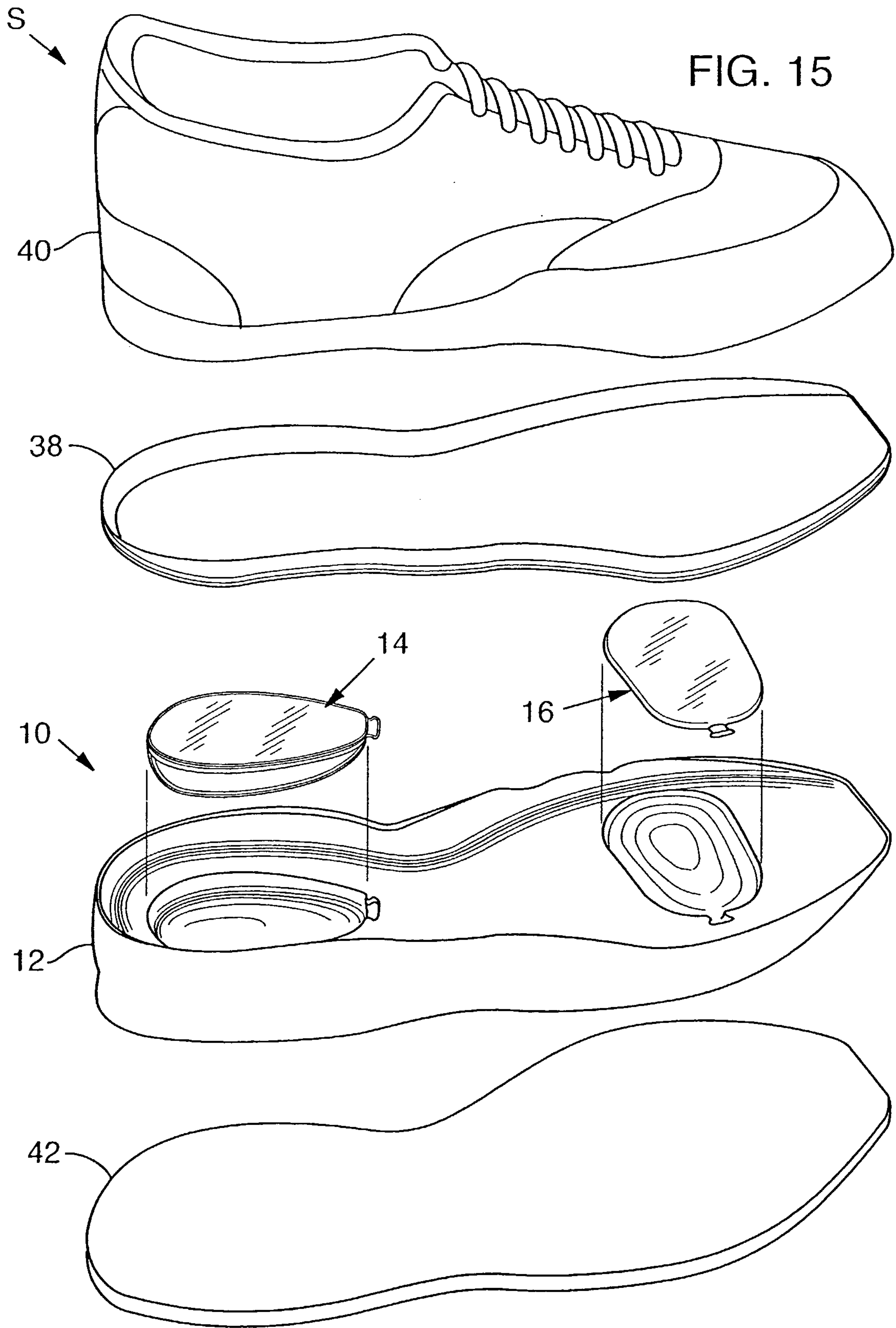

FIG. 16A

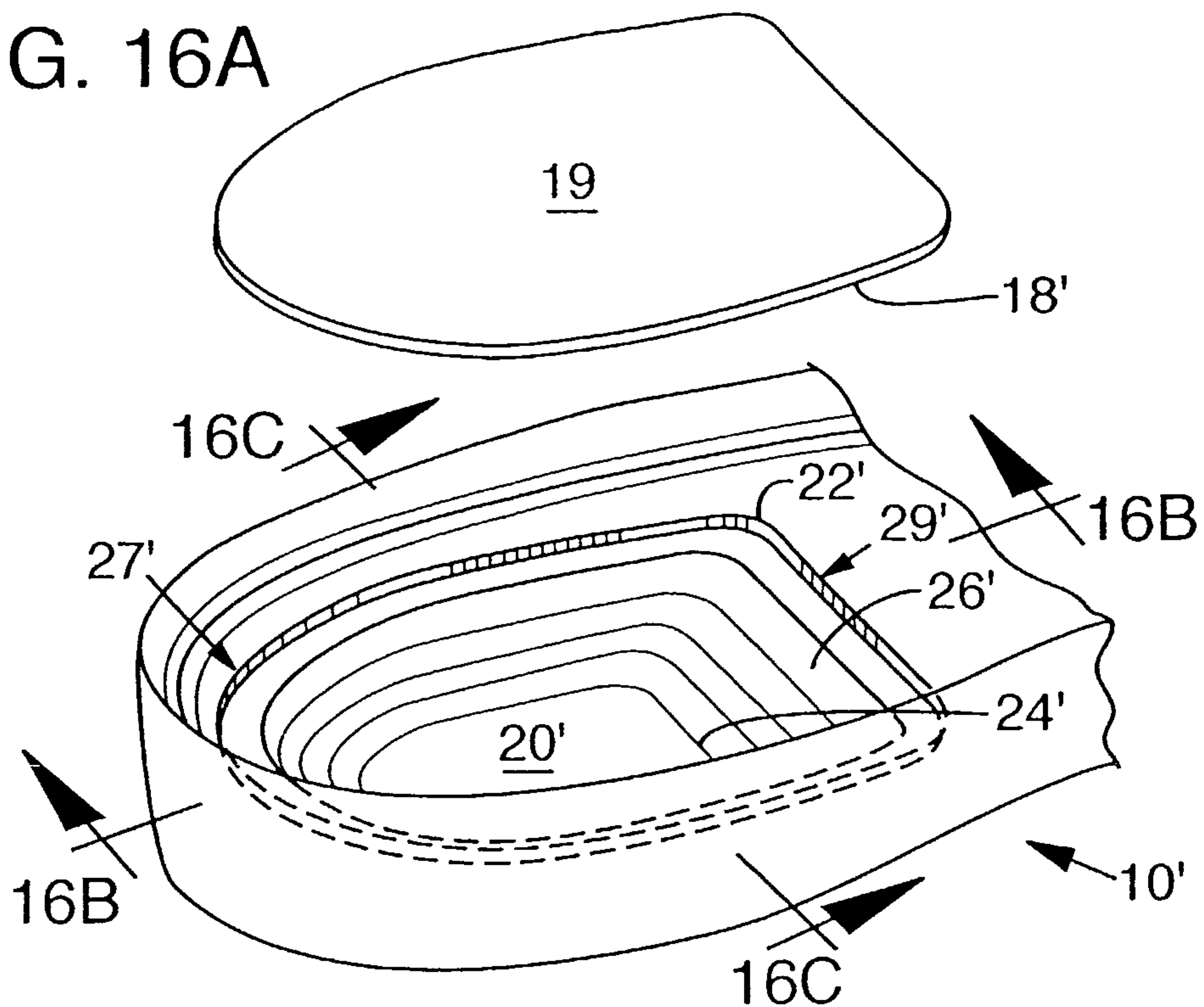

FIG. 16B

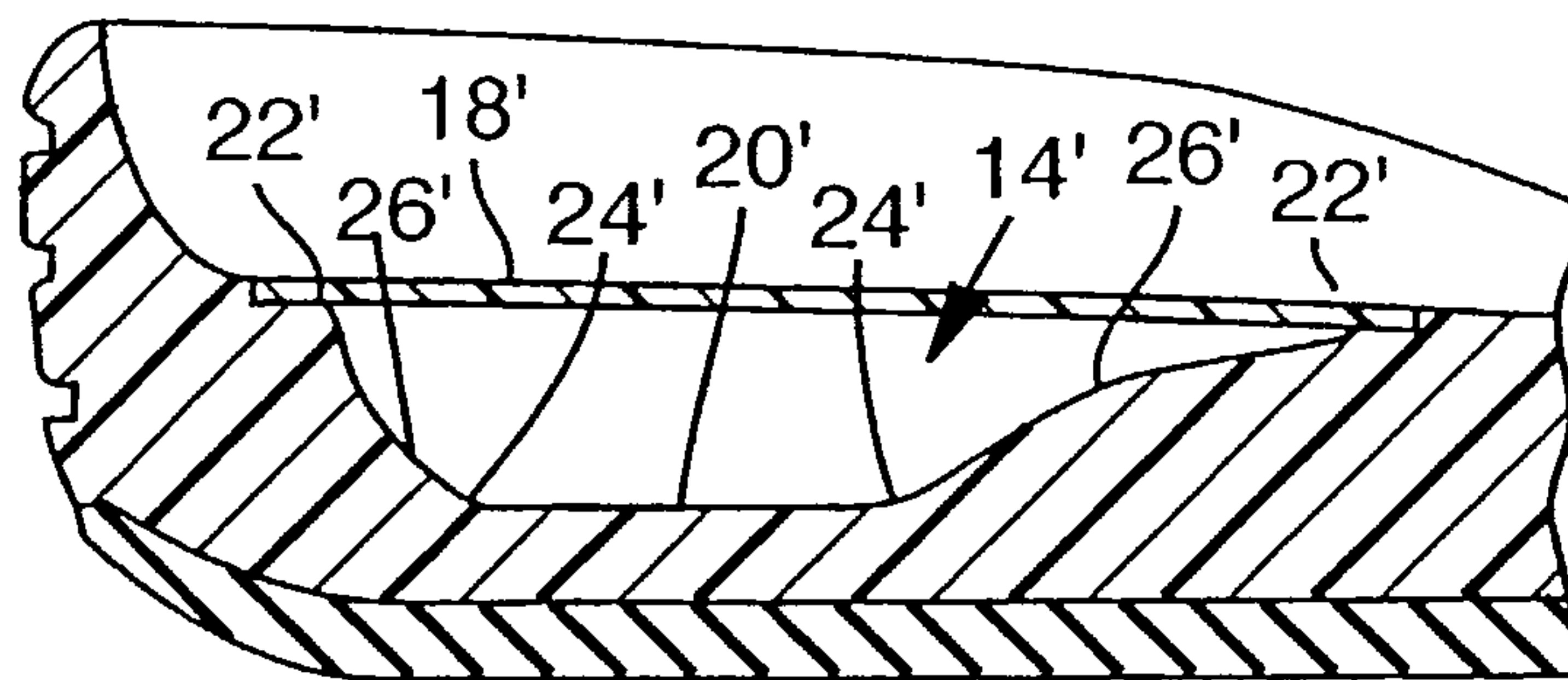

FIG. 16C

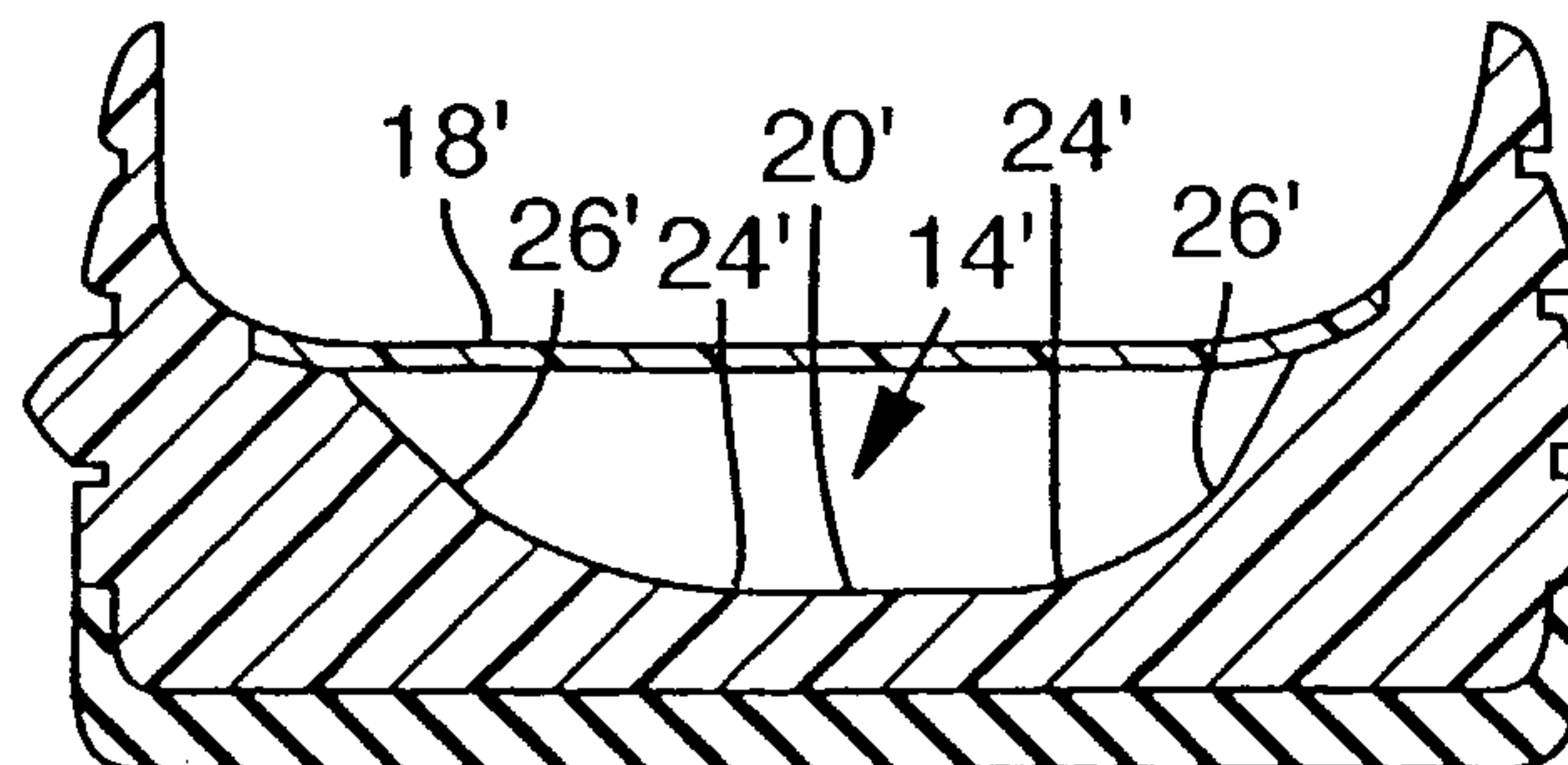

FIG. 17A

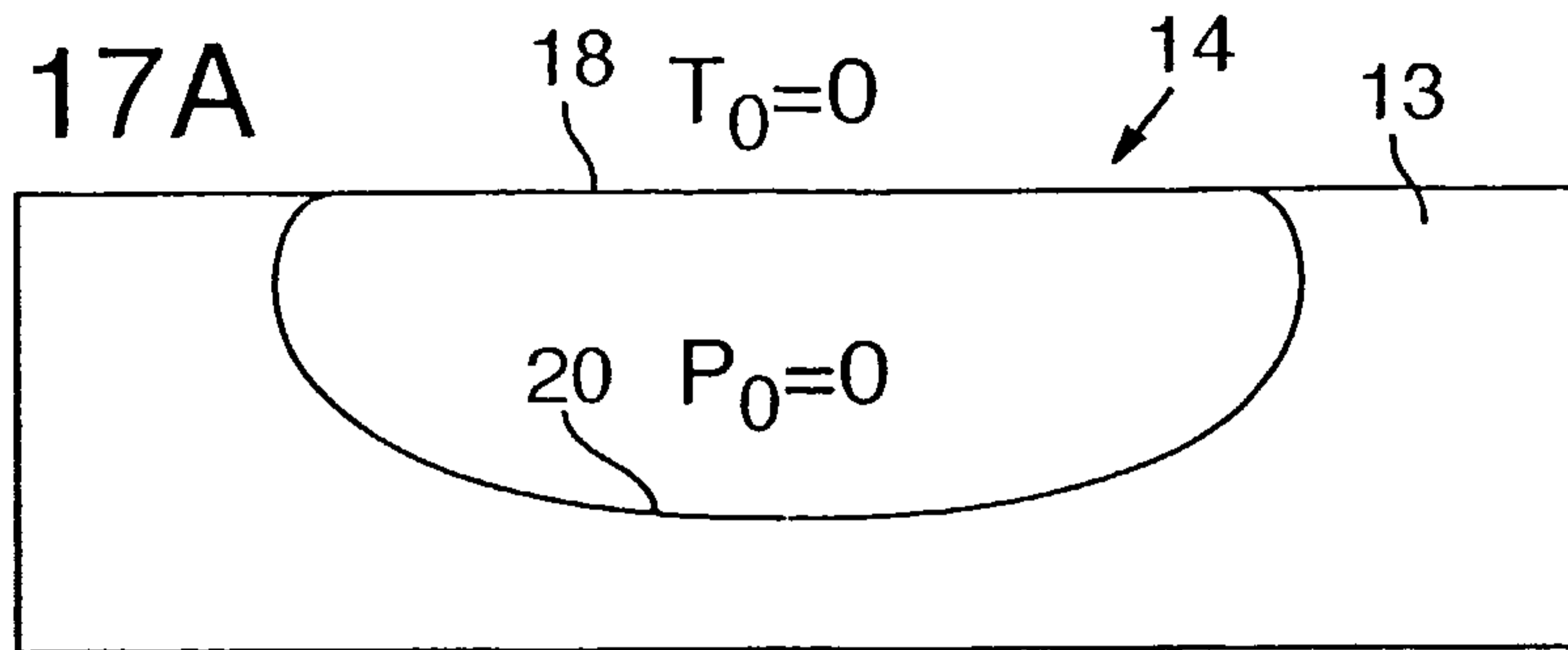

FIG. 17B

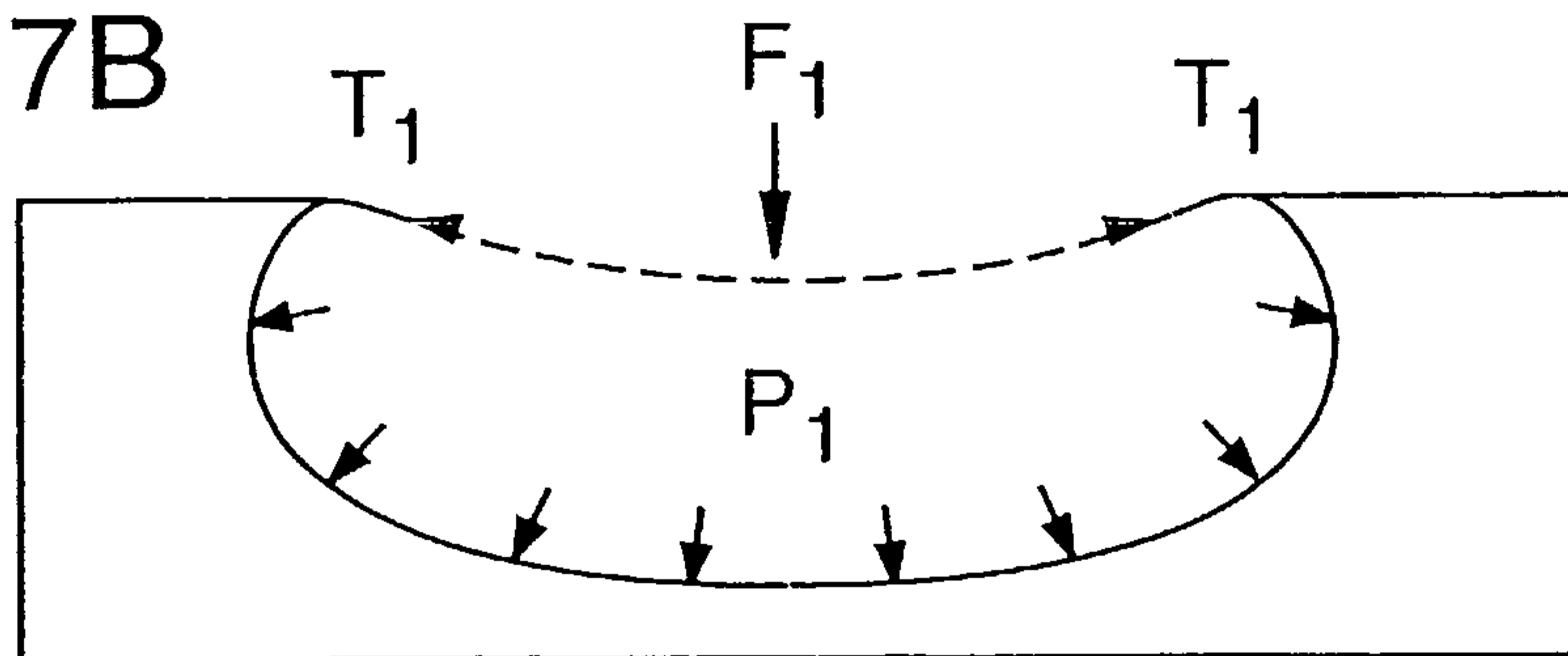
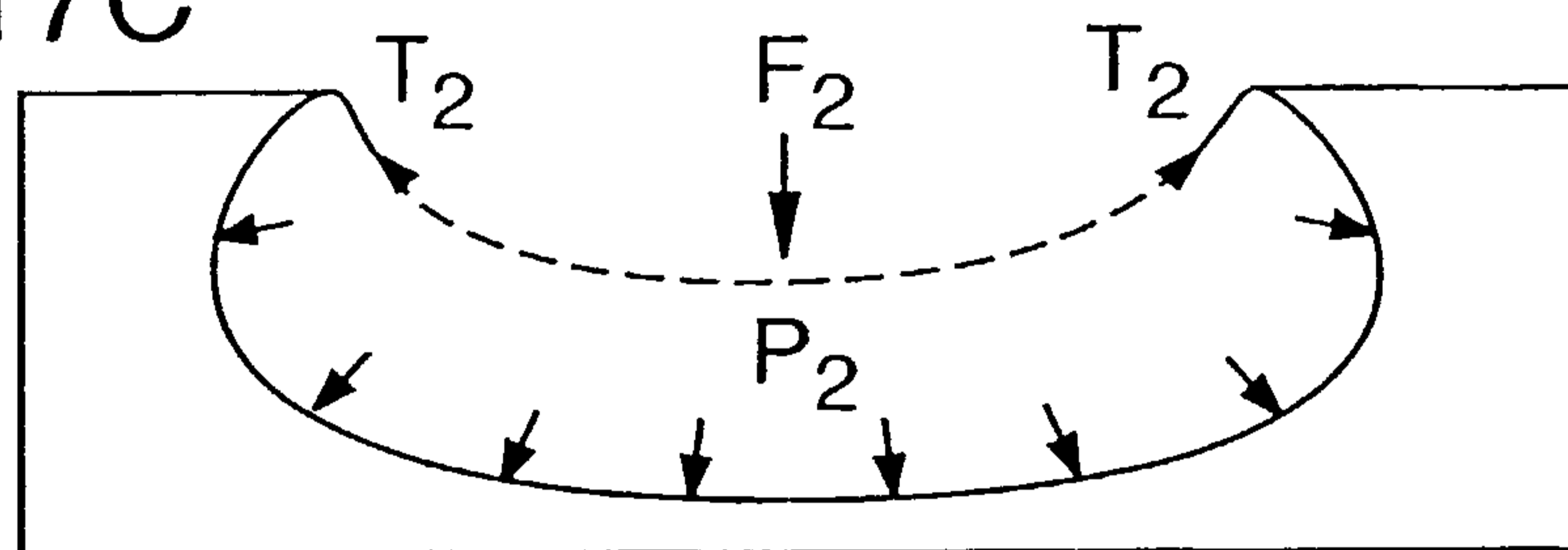

FIG. 17C



$$P_2 > P_1 > P_0$$

$$T_2 > T_1 > T_0$$

FIG. 17D

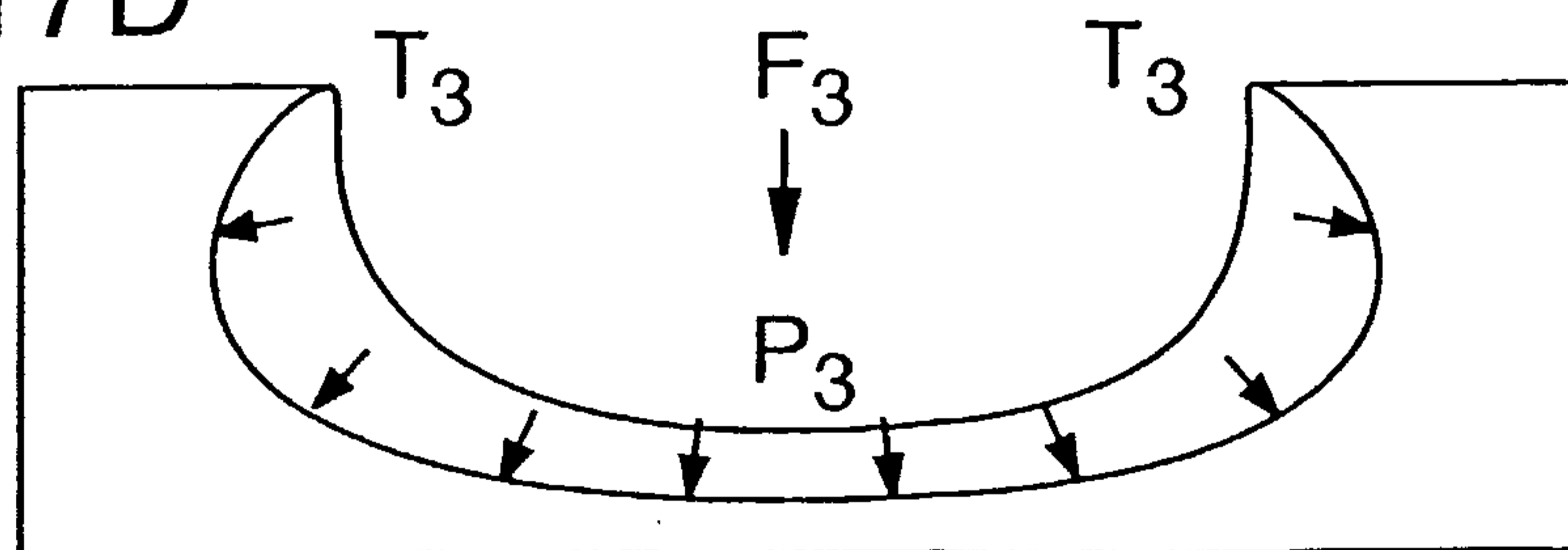

$$P_3 > P_2 > P_1 > P_0$$

$$T_3 > T_2 > T_1 > T_0$$

