

(No Model.)

2 Sheets—Sheet 1.

J. DEVANTERY.

COIN CONTROLLED STRENGTH TESTING MACHINE.

No. 385,921.

Patented July 10, 1888.

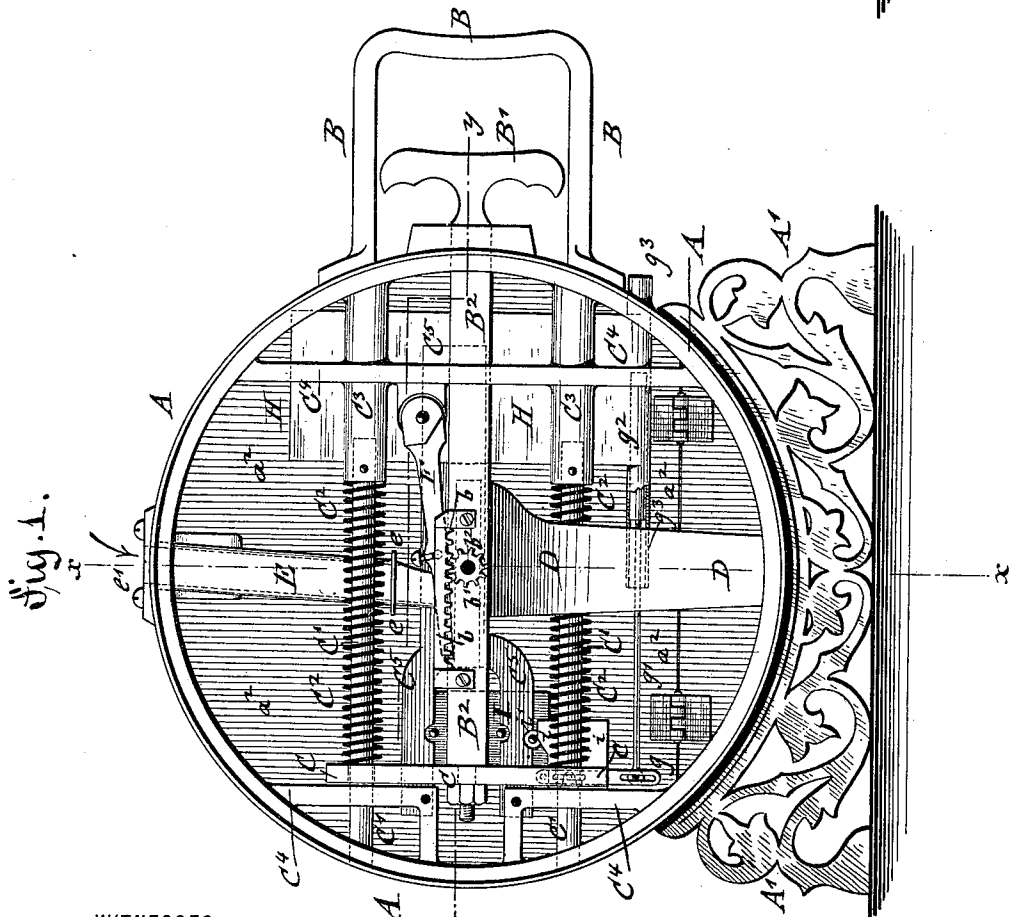
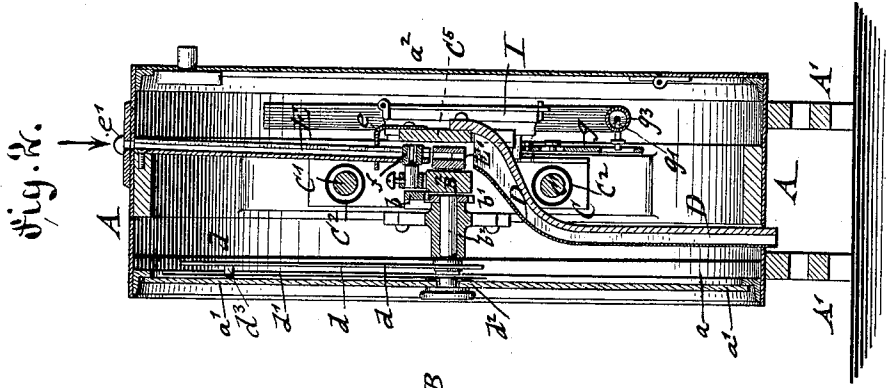

WITNESSES:
Wm. N. Rosenbaum.
Henry Gram.

INVENTOR,
Joseph Devantery.
 BY
Super & Pargason.
 ATTORNEYS

J. DEVANTERY.

COIN CONTROLLED STRENGTH TESTING MACHINE.

No. 385,921.

Patented July 10, 1888.

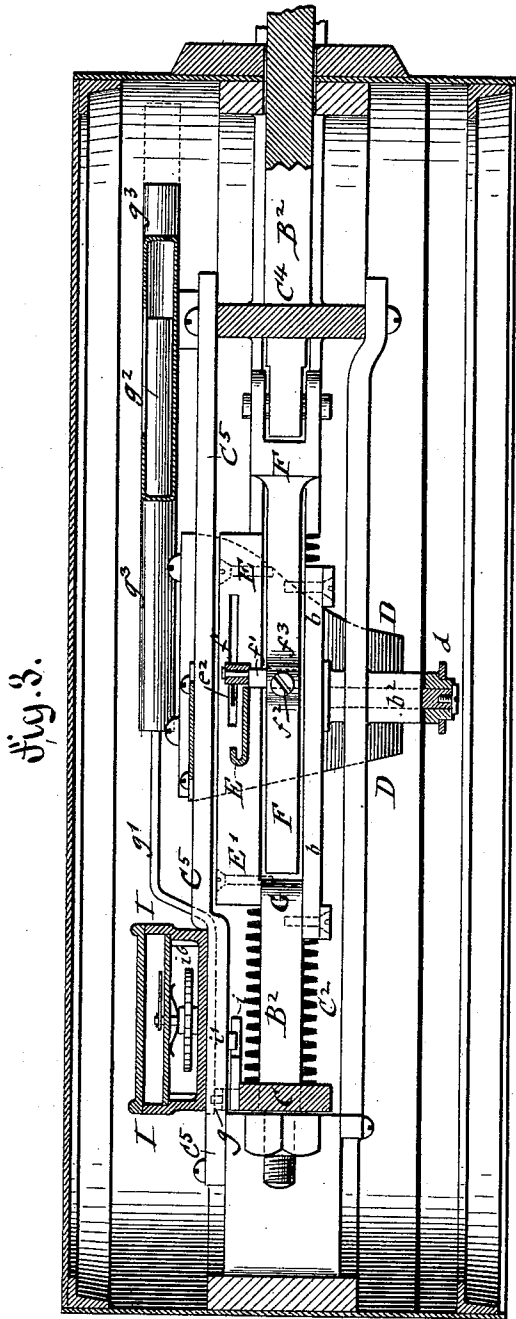

fig. 3.

WITNESSES: A

Edw. H. Rosenbaum.
Henry Mann.

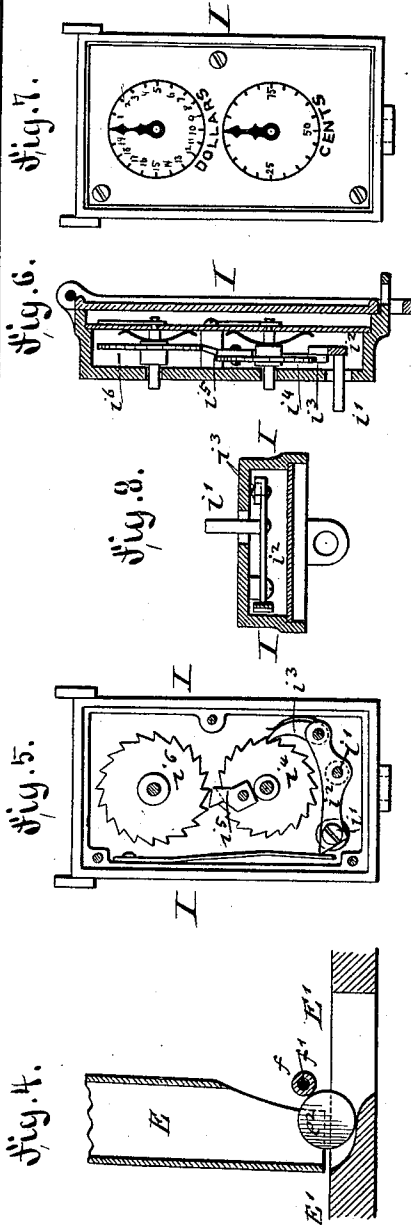

fig. 7.

fig. 6.

fig. 8.

fig. 5.

fig. 4.

INVENTOR.

Joseph Devantery.
 BY
Joseph R. Rogers.
 ATTORNEYS.

UNITED STATES PATENT OFFICE.

JOSEPH DEVANTERY, OF BROOKLYN, ASSIGNOR TO THE HAND POWER TEST MACHINE COMPANY, OF NEW YORK, N. Y.

COIN-CONTROLLED STRENGTH-TESTING MACHINE.

SPECIFICATION forming part of Letters Patent No. 385,921, dated July 10, 1888.

Application filed February 17, 1888. Serial No. 264,416. (No model.)

To all whom it may concern:

Be it known that I, JOSEPH DEVANTERY, of Brooklyn, in the county of Kings and State of New York, have invented certain new and useful Improvements in Coin-Controlled Strength-Testing Machines, of which the following is a specification.

This invention relates to an improved coin-controlled strength-testing machine of that class which is known as "hand-power-testing" machines, and which works only when the mechanism is automatically released by dropping a suitable coin into the same.

The invention relates more especially to certain improvements in the coin-controlled strength-testing machine for which Letters Patent were granted to Ferdinand Mosser, No. 381,409, dated April 17, 1888; and the invention consists of certain improvements in the coin-controlled strength-testing machines of the class described, by which the more reliable working of the machine is produced when the coin is dropped into the machine, the same readily adjusted to work with coins of different size, a more accurate record of the power of the muscles of the hand made, and a register provided for counting and registering the number of coins dropped in the machine.

In the accompanying drawings, Figure 1 represents a front elevation of my improved coin-controlled strength-testing machine, shown with the dial removed. Fig. 2 is a vertical transverse section on line *x x*, Fig. 1. Fig. 3 is a horizontal section of the same on line *y y*, Fig. 1, drawn on a larger scale and without the covering glass plate and auxiliary hand. Fig. 4 is a detail section of the coin-releasing mechanism; and Figs. 5, 6, 7, and 8 are details of the coin-registering device used in connection with the machine.

Similar letters of reference indicate corresponding parts.

Referring to the drawings, A represents a casing of cylindrical shape, which is provided at the front part with a dial, *a*, and a glass plate, *a'*, and at the rear part with a hinged door, *a''*, which is locked to the casing A in any approved manner. The casing A is supported on a suitable stand, *A'*, and provided at one side with a fixed handle, B, and within

the same with a movable handle, B', from which extends a slide-rod, B², to the interior of the casing A. The slide-rod B² is provided at the inner end with a cross-bar, C, which is guided by openings on fixed rods C' at the interior of the casing and acted upon by strong spiral springs C², which are interposed between the cross-bar C and the fixed sockets C', to which the guide-rods C' are applied, as shown in Fig. 1. To the slide-rod B² is attached a rack, *b*, which meshes with a pinion, *b'*, to the shaft *b''* of which is applied the pointer or hand *d*. A second auxiliary hand, *d'*, is applied by a friction-spring, *d''*, to the glass plate *a'* and attached to the inner end of a button, *d'''*, the shank of which is supported in a central opening of the glass plate *a'*, as shown in Fig. 2. The auxiliary hand *d'* is taken along by a pin, *d''*, on the hand *d* when the latter is actuated by the motion of the slide-rod B², rack *b*, and pinion *b'*. When the movable handle B is released, the hand *d* is returned by the action of the springs C² on the slide-rod B² to its normal position. The auxiliary hand *d'* remains in the position to which it has been moved by the hand *d* and indicates accurately the power of the muscles on the dial. The auxiliary hand *d'* is then returned to zero by taking hold of the button *d'''*, so as to be ready for the next operation of the machine.

The casing A is stiffened by upright braces C¹, which are connected by a horizontal bar, C², near the middle of the casing. To the connecting-bar C² is attached a bracket-plate, *e*, which serves to support the lower end of a coin-tube, E, that extends from a slot, *e'*, at the top of the casing in downward direction and communicates with a coin-pocket, E', which is located back of the slide rod B². The coin *e''*, by which the hand-power-testing mechanism is released, is dropped through the slot *e'* and conveyed through the coin-tube E and the lower open end of the same into the coin-pocket E', as shown clearly in Fig. 4. The coin-pocket E' is formed of a slotted block which is attached by screws to the slide-rod B². The end of the coin-pocket E' next below the opening of the coin-tube E is curved or inclined so as to conduct the coin *e''* dropped through the coin-tube E along the curved or

inclined end of the coin-pocket into contact with an anti-friction roller, f , as shown in Fig. 3. The lower end of the coin-tube E is also open and made tapering at that side adjoining the roller f , so as to provide the required space for the motion of the coin e^2 and the anti-friction roller f . The roller f is applied loosely to a pivot, f' , which is attached to a latch, F, that is hinged at one end to a lug of one of the braces C^4 of the casing A, while the opposite end of the latch F abuts against a raised stop, G, of the slide-rod B^2 , as shown clearly in Figs. 1 and 3. When the coin e^2 arrives at the lower end of the coin-tube E, it moves along the curved or inclined end of the slotted coin-pocket E' and forms contact with the anti-friction roller f of the latch F below the center of the roller f , as shown in Fig. 4. When the movable handle B' is then moved toward the fixed handle B, the rod B^2 and coin-pocket E' are carried along and the coin e^2 moved below the roller f , so that the latter rides over the coin and serves to lift the latch F clear of the stop or abutment G, so that the slide-rod B^2 can be moved below the latch F against the tension of the springs C^2 as far as it can be pulled by the muscles of the hand operating the handle. As soon as the roller f has passed over the coin, the said coin is dropped through the slot of the coin-pocket E' into a chute, D, below the pocket and conducted by the same into a suitable receptacle at the bottom of the casing. (Not shown in the drawings.) When the movable handle B' is released by the hand, the slide-rod B^2 is moved inward again, so that the latch F re-engages the abutment G and locks the parts in position until the latch is again released by the next dropping of a coin and operating of the handle B' . The pivot f' of the anti-friction roller f is arranged eccentrically on its shank, the latter being secured by a set-screw, f^2 , into a socket, f^3 , of the latch F, as shown clearly in Figs. 2 and 3. The eccentric pivoting of the anti friction roller f permits the adjustment of the latter for coins of different sizes, so that the same machine can be readily used either with a one-cent, five-cent, or ten-cent piece, or with coins of different countries, without altering the interior construction of the machine, as it simply requires the adjustment of the anti-friction roller f on the latch F to the proper diameter of the coin.

To the lower part of the cross-head C is applied a downwardly-extending adjustable bar, g , which engages by its slotted end the pivot of a piston-rod, g' , the piston g^2 of which is guided in a horizontal tube, g^3 , which terminates at the outside of the casing. The tube g^3 communicates with the lower open end of a cigarette-receptacle, H. With each forward motion of the movable handle B' a cigarette is pushed through the tube g^3 to the outside, while at each backward motion of the handle

a new cigarette is supplied to the tube g^3 in front of the plunger g^2 from the receptacle H. This feature I do not claim, as it is clearly shown and claimed in the prior application of Ferdinand Mosser, heretofore referred to.

In the casing A is arranged a registering device, I, which is attached to the transverse supporting-bar C^5 and operated by an inclined cam, i , applied to the lower part of the cross-head C, said inclined cam operating a pin, i' , which projects through an opening of the casing of the register I, and is applied to a pivoted and spring-actuated lever, i^2 , provided with a spring-pawl, i^3 . Whenever the pin i' rides down along the cam i , the forward motion of the cross-head C following the motion of the handle B' , the pin i' and pawl i^3 are lowered, while on the return motion of the cross-head C the pin i' rides upward on the cam i and causes the raising of the pin i' and pawl i^3 , and consequently the turning of the ratchet wheel i^4 , with which the pawl i^3 meshes, for the distance of one tooth. By the rotary motion imparted to the ratchet-wheel i^4 a hand is moved along a suitable dial of the registering device, while by a fixed carrying-tooth, i^5 , on the ratchet-wheel i^4 a second ratchet-wheel, i^6 , and hand is turned on a second dial, as customary in registering devices of this class.

The registering device indicates the number of coins dropped in the hand-testing apparatus, and forms thereby a control for the number of times which the same has been used for testing the strength of the muscles of the hand.

Having thus described my invention, I claim as new and desire to secure by Letters Patent—

1. The combination of a fixed handle, a movable handle, a spring-actuated slide-rod attached to said handle, a stop or abutment on said slide-rod, a pivoted latch engaging said abutment, an eccentrically pivoted and adjustable anti-friction roller on said latch, a coin-tube having an open end terminating near the roller, and a coin-pocket attached to the slide-rod and located below the coin tube and the roller, substantially as set forth.

2. The combination of a fixed handle, a movable handle, a slide-rod applied to said movable handle, a cross-head at the inner end of the slide-rod, springs acting on said cross-head, a stop or abutment on the slide-rod, a pivoted latch engaging said abutment, an eccentrically-adjustable anti-friction roller on said latch, a coin tube open at the lower end, a coin-pocket attached to the slide-rod below the coin-tube, and a conducting chute below the coin-tube, substantially as set forth.

In testimony that I claim the foregoing as my invention I have signed my name in presence of two subscribing witnesses.

JOS. DEVANTERY.

Witnesses:

JOHN A. STRALEY,
PAUL GOEPEL.