

No. 626,551.

Patented June 6, 1899.

J. S. MUCKLÉ.
BULKHEAD DOOR.

(Application filed Nov. 23, 1898.)

(No Model.)

2 Sheets—Sheet 1.

Fig. 2.

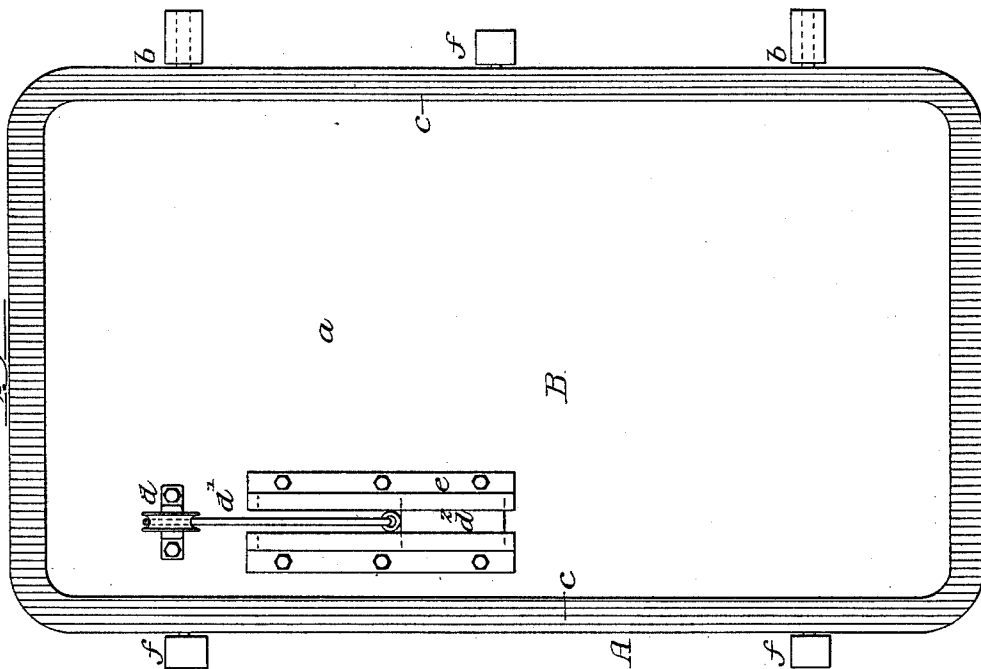
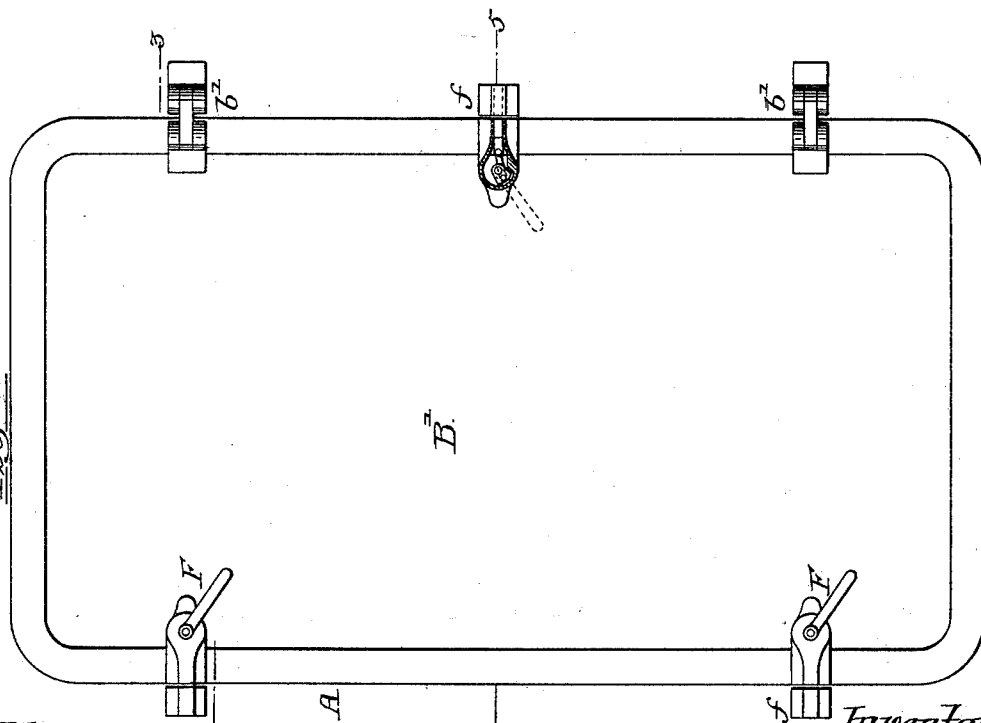

Fig. 1.



Witnesses:
 Frank L. A. Graham
 Louis M. Whitehead.

Inventor:
 John S. Mucklé
 By His Attorneys:
 Horner & Horner

No. 626,551.

Patented June 6, 1899.

J. S. MUCKLÉ.
BULKHEAD DOOR.

(Application filed Nov. 23, 1898.)

(No Model.)

2 Sheets—Sheet 2.

Fig. 3.

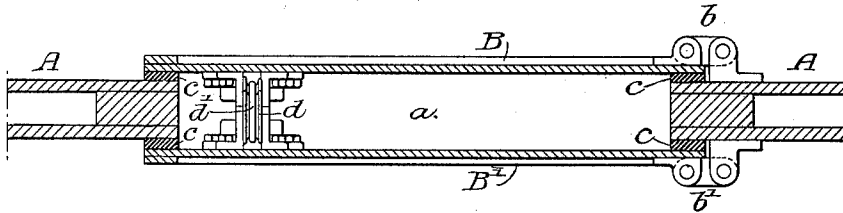

Fig. 4.

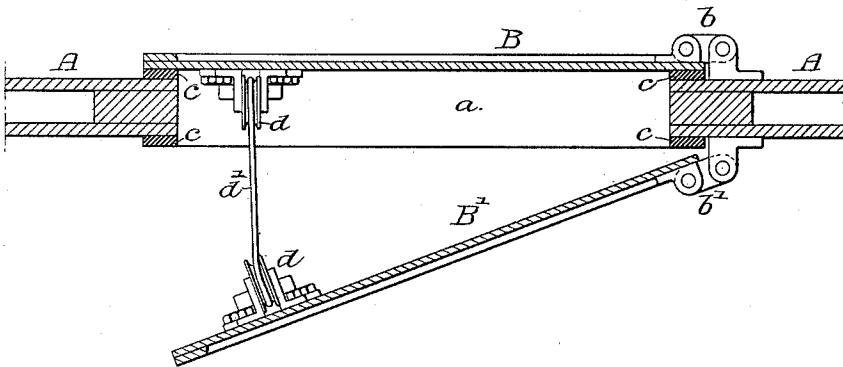

Fig. 5.

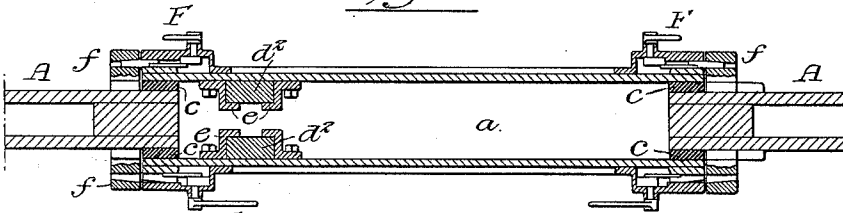
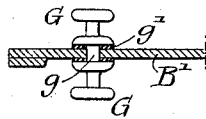

Fig. 6.



Witnesses:-

Frank L. A. Graham.
Louis M. V. Whitehead.

Inventor:

John S. Mucklé
by His Attorneys:-
Howson & Howson

UNITED STATES PATENT OFFICE.

JOHN S. MUCKLÉ, OF PHILADELPHIA, PENNSYLVANIA, ASSIGNOR TO HIMSELF, M. RICHARDS MUCKLÉ, JR., AND T. CARPENTER SMITH, OF SAME PLACE.

BULKHEAD-DOOR.

SPECIFICATION forming part of Letters Patent No. 626,551, dated June 6, 1899.

Application filed November 23, 1898. Serial No. 697,270. (No model.)

To all whom it may concern:

Be it known that I, JOHN S. MUCKLÉ, a citizen of the United States, residing in Philadelphia, Pennsylvania, have invented certain Improvements in Bulkhead-Doors, of which the following is a specification.

The object of my invention is to so construct the doors of a ship's bulkhead as to prevent the flow of water from one bulkhead to another through the doorway. This object I accomplish by providing two doors, one hinged on one side of the bulkhead and the other hinged on the opposite side.

A further object of my invention is to prevent the opening of one door without closing the other, leaving sufficient space, however, to enable a person to pass from one compartment to the other, and the moment the person passes through the doorway the released door will close.

In the accompanying drawings, Figure 1 is a view in elevation of sufficient of a bulkhead, showing one door. Fig. 2 is a view similar to Fig. 1 with one door removed, showing the inner side of the other door. Fig. 3 is a sectional plan view on the line 3 3, Fig. 1, showing both doors closed. Fig. 4 is a view similar to Fig. 3 with one of the doors opened. Fig. 5 is a section on the line 5 5, Fig. 1, showing one door locked by clamps; and Fig. 6 is a view showing the manner of applying knobs to the doors.

Bulkheads upon ships, especially warships, are provided with small doorways, through which a person can pass from one water-tight compartment to another. These doorways are supposed to be normally closed, but in many instances the doors are carelessly left open.

By my invention I dispense entirely with locks and other fastenings for ordinary use and so arrange two doors, one hinged on one side of the bulkhead and the other hinged on the opposite side, and so connect the doors by mechanism that will close both doors tightly against the bulkhead, but either one or the other of the doors can be opened in case a person wishes to pass through the doorway, the opening of one door tending to close the other, and the moment the door is released it will

automatically close. Thus by providing the two doors any leakage of water in one compartment will, when the water rises to a point above the bottom of the door, tend to force the door in the compartment in which the leakage occurs tightly against the bulkhead. I provide clamps for each door, so that the doors on the opposite side of the partition can be rigidly clamped to the bulkhead if a leak is discovered. Thus should water leak past the first-mentioned door the clamped door will prevent water entering the other compartment.

Referring now to the drawings, A is the bulkhead, made in any suitable manner and having a doorway *a* of a size sufficient to allow a person to pass from one compartment to the other.

B B' are doors adapted to close the compartments. The door B is hinged at *b* on one side of the bulkhead, and the door B' is hinged at *b'* on the opposite side of the bulkhead.

I preferably mount on the bulkhead surrounding the doorway or on each door a flexible water-tight packing-strip *c*, preferably of rubber, and I make the hinges *b b'* of the doors double-pivoted hinges, so that they will accommodate themselves to the packing *c*, thus making a water-tight joint between the doors and the bulkhead.

I mount near the upper edge of each door pulleys *d d'*, where the thickness of the bulkhead will permit. These pulleys can be mounted directly opposite each other; but if the bulkhead is narrow the pulleys may be arranged one below another, as shown in the drawings. Passing around these pulleys is a wire rope or chain *d'*, attached to weights *d²*, adapted to guideways *e* on each door, so that the tendency of the two weights, whether one or the other door is opened, is to close the open door, and if one door is opened before the other is completely closed the weights will act to close both doors. Springs or weighted levers may be substituted for the weights, if desired.

As a precaution against leakage I provide each door with bolts F of any suitable construction, preferably of the sliding type, as shown in Figs. 1 and 5, and on the bulkhead

are keepers *f*. The bolts are tapered so that when they are forced into their keepers they will force the doors tight against the packing *c*, thus making an absolutely water-tight joint.

5 I have shown three of these bolts on the door, two on one side and one on the opposite side; but it will be understood that any number of bolts may be used as desired.

10 In some instances knobs may be provided for the doors. I simply use a double knob *G*, as shown in Fig. 6, having a spindle *g* passing through an opening in the door, with washers *g'* on each side to prevent leakage.

15 It will thus be seen that by my invention I dispense entirely with locks, which may be carelessly left unfastened. I provide two hinged doors, one on one side of the bulkhead and the other on the opposite side, and so connect the doors that on the opening of one the
20 other will be closed and as soon as the last door is released it will also be closed, so that in the event of leakage in either compartment one or other of the doors will be forced against the bulkhead.

25 I claim as my invention—

1. The combination in a bulkhead, of two doors, one on each side of the bulkhead and hinged so as to swing outward, and connections between the doors whereby they are normally both held closed and whereby the opening of one door will tend to close the other,
30 substantially as described.

2. The combination of a bulkhead, two doors, one on each side of the bulkhead, and
35 hinged so as to swing outward, a weighted cord connected to both doors and so arranged

that the opening of one door will tend to close the other and the moment either door is released it will be automatically closed, substantially as described. 40

3. The combination in a bulkhead, of two doors, one hinged on one side of the bulkhead and the other on the opposite side thereof, a guide on each door, a single cord or chain adapted to pass through both guides and a
45 weight suspended from each end of said cord or chain, substantially as described.

4. The combination of a bulkhead, packing-strips on each side of the bulkhead surrounding the doorway, two doors one mounted on
50 one side of the bulkhead and the other on the opposite side, double-jointed hinges for the doors, pulleys secured to the inner side of each door, slideways on each door, a weight adapted to each slideway, a cord or chain se-
55 cured to the weights and passing over the two pulleys, substantially as described.

5. The combination in a bulkhead, of two doors, one hinged on one side of the bulkhead and the other on the opposite side thereof, a
60 pulley on each door, the pulley on one door being mounted above the pulley on the other door, and a weighted cord passing around said pulleys, substantially as described.

In testimony whereof I have signed my
65 name to this specification in the presence of two subscribing witnesses.

JOHN S. MUCKLÉ.

Witnesses:

WILL. A. BARR,
JOS. H. KLEIN.