

19



Octrooi centrum
Nederland

11

2038331

12 A OCTROOIAANVRAAG

21

Aanvraagnummer: **2038331**

51

Int. Cl.:
H02H 5/04 (2024.01) **H01H 37/76** (2024.01) **H01H 85/02** (2024.01) **A62C 3/16** (2024.01)

22

Aanvraag ingediend: **25 juli 2024**

62

30

Voorrang:
26 juli 2023 CZ 2023-286

71

Aanvrager(s):
MEGELLAN, SE te Praha 3 - Žižkov, Tsjechië, CZ

41

Aanvraag ingeschreven:
6 februari 2025

72

Uitvinder(s):
Marek Duda te Bohumín, Nový Bohumín (CZ)

43

Aanvraag gepubliceerd:
6 februari 2025

74

Gemachtigde:
dr. ir. G.J.C. Verdijck c.s. te Den Haag

54

Protective equipment for switchboards and switchboard monitoring system

57

A protective device for switchboards consisting of a carrier(10), further provided with at least one fuse base(1a) for fixing the fuse(1b), at least one thermal fuse(7), furthermore at least one supply/drain contact(3), at least one disconnecting contact(4), at least one input/output contact(2a), (2b), wherein the input/output contact(2a), (2b) is designed to connect conductors for bidirectional flow of electric current, the fuse base(10) is removably connected, the thermal fuse(7) is arranged to perform the function of activating the disconnecting and/or extinguishing function, and/or further comprising at least one network module(26) for monitoring the protective device, and/or at least one mount for the extinguishing medium tank(5), wherein the extinguishing medium tank(5) is removably connected to the carrier(10). A switchboard monitoring system containing at least one electrical box(25) housing at least one protective device, a network module(26) and/or a fire extinguisher, further comprising at least one distribution box(28), at least one parent entity/object transceiver(29) and at least one transformer station(16).

Protective equipment for switchboards and switchboard monitoring system

Field of the Invention

Protection of electrical installations, low and high voltage electrical switchboards, low and high
5 voltage distribution switchboards and electrical junction boxes, switchboards for public
distribution networks, switchboards for busbar trunking systems and construction site switchboards
from undesirable rising temperature and/or flame burns.

Background of the Invention

10 The closest prior art is invention application No. CZ PV 2022-246, with a priority date of June 8th
2022, which describes a passive device for protecting an electrical junction box supplying
electrical power to a building from undesirable elevated temperature or flame burns, which
comprises a tank containing the extinguishing medium, a plunger arranged in an opening in the
upper part of the tank and a plunger is immersed inside the tank, wherein a seal for sealing the
15 extinguishing medium tank is a part of the plunger, and a disconnecting contact made of
electrically conductive material is attached to the upper part of the plunger, and a thermal fuse is
attached to the upper part of the plunger and a protective frame is arranged above the thermal fuse,
which is rigidly connected to the carrier, wherein the passive device for protecting the electrical
junction box is arranged in a first part of the carrier and a fuse is arranged in a second part of the
20 carrier in the fuse base to protect the electrical circuits in the building from short circuit and
overload, wherein the first part of the carrier and the second part of the carrier form one compact
unit, wherein at least one input contact and at least one branching contact are arranged at the end of
the first part of the carrier and an output contact is arranged at the end of the second part of the
carrier.
25 The disadvantage of this solution is the possibility to use only one type of fuses that are compatible
with the fuse base. Passive device can only be used with a tank for extinguishing medium, it cannot
be used when only disconnection from the power source is required. The protective device can
only be inspected by a direct on-site inspection.

30

Summary of the Invention

The aforementioned disadvantages are eliminated by the protective device for switchboards, the
principle of which is that it consists of a carrier, and further includes at least one removable fuse
base for fixing the fuse, at least one thermal fuse, at least one supply/drain contact, disconnecting
35 contact, and at least one input/output contact.

In a preferred embodiment, the protective device comprises at least one mount for the extinguishing medium tank.

5 The removable fuse base is compatible with all variants, types and sizes of fuses, the fuse selection is made according to the voltage and current magnitude. The fuse protects electrical circuits from short circuit and overload. The fuse base is arranged in the second part of the carrier.

The protective device is compatible for currents 0-1500 A and voltages 0-1000 V.

10 The thermal fuse is arranged to act as an activator of the disconnecting or possibly extinguishing function; it is used to disconnect from the power supply. It consists, for example, of a glass capsule which breaks when the temperature in the low- and high-voltage electrical switchboard increases, thereby disconnecting the electrical circuits and releasing the thermal fuse for the eventual discharge of the extinguishing medium if the device has one.

Material fuses based on less temperature-resistant materials such as plastics with different application points are used in another embodiment.

15 The thermal fuse consists of a screw made of a temperature-sensitive material, e.g. polyamide, the structure of which degrades and deforms when the temperature in the low- and high-voltage switchboards increases, thereby disconnecting the electrical circuits and releasing the thermal fuse for the eventual discharge of the extinguishing medium if the device has one.

20 Another embodiment features pins that soften after exceeding the given temperature and break, thereby disconnecting the electrical circuits and releasing the thermal fuse for the eventual discharge of the extinguishing medium if the device has one.

Another embodiment is a switching using a bimetal or a cable, which ignites after contact with fire and release the fuse.

25 The thermal fuse type sets the temperature at which disconnection from the power source and/or extinguishing occurs. Another option to adjust the temperature in the case of electronics is, for example, by the type of bimetal, by adjusting the switching temperature using a temperature sensor, smoke or other indicator.

30 For example, the supply/drain contact is located between the fuse base and the disconnecting contact. The disconnecting contact is located on the connection of the supply/drain contact and the supply/drain contact at the fuse bases. The supply/drain contact carries electricity through the protective device in the switchboard to the electricity consumer or diverts electricity obtained, for example, from renewable sources from the consumer back to the distribution network.

35 The input/output contact carries electricity from the distribution system to the network, or further to the consumer or acts as a contact distributing electricity to another electrical switchboard of low or high voltage. The input/output contact is compatible with v-yoke, cable eye mounting, etc. The

input/output contact is compatible with cables having cross-sections from 10 to 240mm² in shape, material and function. Cables are, for example, aluminum, copper, plated or other electrically conductive materials.

5 If the device has more than one contact, there is a fixed/removable partition between the contacts to separate the contacts mechanically.

The protective device according to claim 1 is mounted in a switchboard, for example, by mounting on a rail compatible for mounting fuse bases, fuses and circuit breakers.

10 The protective device is modular in nature. At least one protective device is provided in the switchboard for at least one phase. In the case of three phases, there are three protective devices in the switchboard. Protective devices can be installed even under live power.

Where protective devices are installed side by side in such close proximity that there are no standard distances for arc flashover, partitions are placed between the individual devices.

If the device has multiple contacts, there is a fixed or removable partition between the contacts to separate the contacts mechanically.

15 The tank for the extinguishing medium is removably attached to the carrier, e.g. by screwing, clicking, gluing, with a screw thread, etc. The device also exists without a tank.

The extinguishing medium in the tank is gaseous or liquid or solid, e.g. granular. The extinguishing medium is selected according to the set temperature for extinguishing.

20 In another embodiment, the protective device includes a temperature sensor, e.g. a bimetal strip, a temperature detector, a smoke or other indicator.

The protective device described above protects the switchboard from undesirable rising temperature and/or flame burns. Protection is carried out by disconnecting from the power source only or by extinguishing only, by discharging the extinguishing medium from the extinguishing medium tank or by disconnecting from the power source and extinguishing at the same time.

25 The advantages of this solution are the possibility of using any fuses thanks to the removable fuse base. Use of any thermal fuse. Thanks to the removable tank, it is possible to use the protective device without the extinguishing option, or the tank can be replaced without the need to uninstall the entire protective device. Another advantage is the possibility to select any thermal fuse. The design of the protective device allows a wide variability of use.

30 If the protection device contains an IoT module, the device can be remotely monitored, and the fault can be detected and repaired very early.

Switchboard monitoring system

35 The system includes at least one electrical box, e.g. a junction box, a low or high voltage switchboard, in which at least one protective device, a network module, e.g. an IoT module and/or

a fire extinguisher is located; it also includes at least one distribution box, at least one receiver, at least one transformer station, wherein the electrical box is connected by cable to the distribution box, the distribution boxes are directly or via another distribution box connected by cable to the transformers station, the electrical boxes are connected to at least one transceiver of the parent entity/object via a wireless communication network, e.g. IoT.

The network module is located in the switchboard and/or in the protective device.

The network module is a monitoring device capable of sending information about fault status in the low and high voltage switchboards. It uses communication networks such as Internet of Things, e.g. IoT SIGFOX, ILoRaWAN, NB-IoT. When IoT networks are unavailable, it can use other nearby communication networks because it has a radio communication module.

The network module contains a microcontroller, a test contact for connecting a fault indication source, e.g. a temperature or smoke detector, at least one temperature sensor/detector, e.g. an analogue temperature sensor, a control unit, a power supply, a radio communication module, communicator and power control unit.

The network module is equipped with an internal or external power source, e.g. induction, power cable or battery, which ensures the functionality of the device throughout its lifetime and distributes the necessary voltage to the entire network module.

To ensure maximum safety and functionality, the network module includes a test contact for connecting the fault indication source that sends messages about functionality, e.g. a test message after installation in the electrical box is sent. This message serves as a verification of the functionality and availability of a communication network, e.g. IoT. It also sends messages at specific time intervals, and warns of insufficient power supply, e.g. end of the battery life, etc. The test contact for connecting the fault indication source is designed so that it cannot be activated by mistake or unauthorised use, a special tool is used, e.g. a special needle or keys. The test message is different from an alarm message, so the parent entity/object does not raise an alarm.

The network module contains encryption to verify the authenticity and validity of the message.

The network module sends information to the transceiver of the parent entity/object to which it is wirelessly connected via communication networks, e.g. cloud, control centre, fire department control centre or building manager.

The network module is made without external metal parts.

The fire extinguisher is made e.g. as a fire hose.

The network module also contains a unique serial number and an encrypted part to verify the validity of the message (either as a part of the IoT protocol/service or as a custom solution). A unique identifier is also placed on the cover of the network module in the form of a QR code.

The system monitors the temperature inside the distribution boxes of the distribution system. The system is connected to the transceiver of the parent entity/object via the communication network

and in the event of an increase the temperature inside the distribution box, it is activated and sends information about exceeding the permitted temperature.

Before placing it in the distribution box, the operator scans the QR code of the network module and the application adds this device to the system including the location (GPS coordinates plus optional description).

After installing the network module in the distribution box, the operator activates the test contact for connecting the fault indication source, and this sends the test message to the transceiver of the parent entity/object and verifies the functionality.

10 During its lifetime, the network module sends status information about its status and power status at a defined time interval. It monitors the functionality of all installed protective devices in the network. It informs the operator e.g. by displaying the location of the event, by acoustic, visual and other signalling, or by other means. The time interval setting is configured based on the customer's
15 need for intervention by the operator of the parent entity/object. Only if no status message is received, the parent entity/object informs the operator about this situation.

If the temperature in the junction box increases, an alarm message is sent to the transceiver of the parent entity/object. A preferred embodiment is provided with at least two temperature detectors,
20 which allows double temperature control and thus prevents false temperature rise reports. After the rising temperature is detected by the first detector, the measurement is made by the second detector. If a temperature rise is also detected on the second detector, an alarm message is sent to the transceiver of the parent entity/object. To ensure delivery, the alarm message is sent multiple times. Immediately after receiving the alarm message, the parent entity/object informs the operator
25 of this event. If the temperature in the junction box continues to rise, the fire extinguisher is activated.

Before the end of the life of the device (1-12 months in advance), the network module sends a message with this information to the transceiver of the parent entity/object, which evaluates this and informs the operator.

30

Brief Description of Drawings

Fig. 1 shows a spatial representation of a protective device equipped with an IoT module.

Fig. 2 shows the system diagram.

Fig. 3 shows the block diagram of the network module.

35 Fig. 4 shows the arrangement of the protective device and the network module in the electrical box.

Fig. 5 detail of the tank with the inlet valve

Fig. 6 removable extinguishing medium tank

Fig. 7 fusible screw for disconnection

Fig. 8 thermal fuse in the form of fusible screw for discharging medium

Fig. 9 detail of the thermal fuse in the form of bimetal - failure-free condition

5 Fig. 10 protective device with the pressure slider

Fig. 11 detail of the thermal fuse in the form of bimetal - failure condition

Fig. 12 protection device with the valve

Other drawings illustrate other examples of embodiments.

- 10 Fig. 13 shows four three-dimensional views of the protective device designed for 1500 A
- Fig. 14 shows four three-dimensional views of the protective device equipped with the thermal fuse in the form of the glass capsule - disconnection of electrical circuits
- Fig. 15a shows a section of the detail of the thermal fuse of the protective device in the form of bimetal for disconnecting electrical circuits - failure-free condition
- 15 15b shows a section of the detail of the thermal fuse of the protective device in the form of bimetal for disconnecting electrical circuits - failure condition
- Fig. 16 shows a three-dimensional view of the detail of the removable attached extinguishing media tank with the thread for fastening
- Fig. 17 shows a three-dimensional view of the detail of the safety gate of the protective device containing a network module with the thermal fuse for disconnecting electrical circuits in the form of a glass capsule - failure-free condition
- 20 Fig. 18 shows eight three-dimensional views of the protection device equipped with the actuator for disconnecting electrical circuits
- views a, b, c, d show the protective device only with the medium tank mount
- 25 views e, f, g, h show the protective device with the extinguishing media tank removably attached to the medium tank mount
- Fig. 19 shows eight three-dimensional views of the protective device with the removable extinguishing medium tank
- views a, b, c, d show the protective device only with the medium tank mount
- 30 views e, f, g, h show the protective device with the extinguishing media tank removably attached to the medium tank mount
- Fig. 20 shows four three-dimensional views of the protective device equipped with the thermal fuse in the form of the glass capsule for disconnecting electrical circuits with the extinguishing medium tank mount in the position by the locking ring

- Fig. 21 a, b, c, d shows three-dimensional views of the protective device equipped with the thermal fuse in the form of bimetal for disconnecting electrical circuits and with the medium tank mount - failure condition
- 5 e) shows a side view of the protective device equipped with the thermal fuse in the form of bimetal for disconnecting electrical circuits and with the medium tank mount - failure condition
- f) shows a section of the detail of the thermal fuse of the protective device in the form of bimetal for disconnecting electrical circuits - failure condition
- Fig. 22 a, b, c, d show three-dimensional views of the protective device equipped with the thermal fuse in the form of bimetal for disconnecting electrical circuits - failure-free condition
- 10 e) shows a side view of the protective device equipped with the thermal fuse in the form of bimetal for disconnecting electrical circuits - failure-free condition
- f) shows a section of the detail of the thermal fuse of the protective device in the form of bimetal for disconnecting electrical circuits - failure-free condition
- 15 Fig. 23 shows two three-dimensional views of the protective device equipped with the screw with the definable plastic deformation temperature for discharging the extinguishing medium - failure-free condition
- Fig. 24 shows two three-dimensional views of the protective device equipped with the screw with the definable plastic deformation temperature for discharging the extinguishing medium - failure condition
- 20

Examples of Invention Embodiments

The attached figures show examples of embodiments.

25

Example 1

The protective device consists of a carrier 10 and further includes at least one removable fuse base 1a for fixing the fuse 1b, compatible with all types and sizes of fuses, the protective device being compatible with currents 0-1,500 A and voltages 0-1,000 V.

30

Furthermore, the protective device includes at least one supply/drain contact 3, which is located between the fuse base 1a and the disconnecting contact 4. The supply/drain contact 3 carries electrical energy through the protective device in the switchboard further to the electricity customer or diverts electrical energy obtained, e.g. from renewable sources, from the customer back to the distribution network.

The protective device further includes at least one mount 10.1 for the extinguishing medium tank 5. The extinguishing medium tank 5 is removably connected to the carrier 10, in this embodiment example by a screw.

The extinguishing medium in the extinguishing medium tank 5 is gaseous.

- 5 The protective device has two input/output contacts 2a and 2b and there is a fixed partition 11 between the contacts for mechanical separation of input/output contacts 2a and 2b.

The protective device is modular in nature. There is one protective device in the switchboard for each phase. In the case of three phases, there are three protective devices in the switchboard.

- 10 Protective devices can be installed even under live power.

Protective devices are installed three side by side; in order to observe the specified standard distance for the arc flashover, partitions are placed between the individual devices.

- 15 Furthermore, the protective device comprises a thermal fuse 7 for disconnecting the electrical switchboard from the power source, wherein the thermal fuse 7 is provided by a glass capsule, which, when the temperature in the low or high voltage electrical switchboard increases, bursts, thereby disconnecting the electrical circuits / disconnecting the electrical switchboard from the power source and/or releasing the thermal fuse for possible discharging of the extinguishing medium from the extinguishing medium tank 5.

20

The device also includes an IoT module.

Example 2

- 25 The thermal fuse of the protective device consists of a polyamide bolt arranged on a carrier, the structure of which degrades and deforms as the temperature increases in the low or high voltage switchboards, thus disconnecting the contacts and disconnecting the electrical switchboard from the power supply and/or releasing the thermal fuse for the eventual discharge of the extinguishing medium if the device has one.

30 Example 3

- The thermal fuse of the protective device is in the form of a shear pin, which is arranged in the gate where it secures the push pin. After exceeding the given / set temperature in the electrical switchboard, the pin softens and breaks/cuts off, thus causing the push pin to come out, disconnecting the contacts and disconnecting the electrical switchboard from the electrical supply
35 and/or releasing the discharge pin for eventual discharge of the extinguishing medium if the device has one.

Example 4

The thermal fuse of the protective device is switched by a bimetal, a wire that ignites upon contact with fire and the fuse is released.

5

Example 5 - Switchboard monitoring system

The system comprises six electrical boxes 25, each housing three protective devices, one network module 26, in this example embodiment an IoT module, and a fire extinguisher, as well as three distribution boxes 28, one transceiver 29 of the parent entity/object, in this case of a control centre, and two transformer stations 30, wherein the electrical boxes 25 are connected by cable to the distribution box 28, the distribution boxes 28 are directly or via another distribution box 28 connected by cable to the transformer station 30, and the electrical boxes 25 are connected by a wireless communication network, in this case an IoT network, to the receiver 29 of the control centre.

10

15 IoT modules 26 are located in the electrical box 25, one IoT module 26 is located in each electrical box 25.

The IoT module 26 is a monitoring device capable of sending information about fault status in the low and high voltage electrical box 25. It uses communication networks, in this case Internet of Things networks, IoT SIGFOX. When IoT networks are unavailable, it can use other communication networks nearby because it is equipped with a radio communication module 36.

20

The IoT module 26 includes a microcontroller 31, a test contact 32 for connecting the fault indication source, a first temperature detector 33.1 and a second temperature detector 33.2, in this case an analogue temperature detector, a control unit 34, a power source, in this case a battery 35, a radio communication module 36, communicator 27 and power control unit 37.

25

To ensure maximum safety and functionality, the IoT module 26 includes a test contact 32 for connecting the fault indication source that sends messages about functionality, e.g. it sends a test message after installation in the electrical box 25. This message serves to verify the functionality and availability of the IoT network. It also sends messages at certain time intervals, and warns of insufficient power supply, e.g. end of the battery 35 life, etc. The test contact 32 for connecting the fault indication source is designed in such a way that it cannot be activated by mistake or without authorisation, a special tool is used, e.g. a special needle. The test message is different from an alarm message, so the parent entity/object does not raise an alarm.

30

The IoT module 26 contains encryption to verify the authenticity and validity of the message.

IoT module 26 sends information to receiver 29 of the control centre, to which it is wirelessly connected via IoT networks.

35

IoT module 26 is made without the presence of metal parts.

Fire extinguisher is made e.g. as a hose.

IoT module 26 also contains a unique serial number and an encrypted part to verify the validity of the message. The unique identifier is also located on the cover of the network module 26 in the form of a QR code.

5 The system monitors the temperature inside the electrical boxes of the distribution system. The system is connected to the receiver 29 of the control centre via the IoT network and in the event of an increase the temperature inside the distribution box, it is activated and sends information about exceeding the permitted temperature.

10 Before placing it in the electrical box 25, the operator scans the QR code of the IoT module 26 and the application adds this device to the system including the location (GPS coordinates plus optional description).

After installing the IoT module 26 in the electrical box 25, the operator activates the test contact 32 to connect the fault indication source, thereby sending the test message to the control centre receiver 29 and verifying the functionality.

15

During its lifetime, the IoT module 26 sends status information about its status and power status at a defined time interval. It monitors the functionality of all three installed protective devices in the electrical box. It informs the operator e.g. by displaying the location of the event, by acoustic, visual and other signalling, or by other means. The time interval setting is configured based on the request for the cost of traffic (cost per message sent). These messages are processed without the need for intervention by the operator of the control centre. Only if no status message is received, the control centre informs the operator of this situation.

20 If the temperature rises in the electrical box 25, an alarm message is sent to the control centre receiver 29. The described embodiment is provided with two temperature detectors 33.1 and 33.2, which allows double temperature control and thereby prevents false temperature rise messages. After the rising temperature is detected by the first detector 33.1, the measurement is made by the second detector 33.2. If a temperature rise is detected on the second detector 33.2, an alarm message is sent to the control centre receiver 29. To ensure delivery, the alarm message is sent multiple times. Immediately after receiving the alarm message, the control centre informs the operator of this event. If the temperature in the electrical box 25 continues to rise, the fire extinguisher is activated.

30 Reference Signs List

1a) fuse base

35 1b) fuse

2a) input/output contact

- 2b) input/output contact
- 3) supply/drain contact
- 4) disconnecting contact
- 5) extinguishing medium tank
- 5 6) lower lid of the fixed extinguishing medium tank
- 7) thermal fuse
- 8) safety gate
- 9) discharge pin
- 10) carrier
- 10 10.1) medium tank mount
- 11) removable partition
- 12) three-point compression spring
- 13) spacer
- 14) screw with the definable plastic deformation temperature for disconnection
- 15 15) inlet valve
- 16) sealing screw
- 17) electrically operated pressure slider
- 18) electrically operated discharge valve
- 19) pressure slider
- 20 20) bimetallic element
- 21) locking stop
- 22) disconnecting pin
- 23) screw with the definable plastic deformation temperature for discharging extinguishing medium
- 25 24) lifting spring
- 25. electrical box
- 26. network module
- 27. communicator
- 28. distribution box
- 30 29. transceiver of the parent entity/object
- 30. transformer station
- 31. microcontroller
- 32. test contact for connecting the fault indication source
- 33.1 detector/sensor
- 35 33.2 detector/sensor
- 34. control unit

35. power source

36. radio communication module

37. power control unit

CONCLUSIES

1. Een beveiligingsinrichting voor schakelborden omvattende een drager (10), verder
5 voorzien met ten minste een zekeringhouder (1a) voor het bevestigen van de zekering (1b),
ten minste een thermische zekering (7), ten minste een voedings-/aftapcontact (3), ten
minste een scheidingscontact (4), ten minste een ingangs-/uitgangscontact (2a), (2b)
gekenmerkt door het feit dat het ingangs-/uitgangscontact (2a), (2b) ontworpen is om
geleiders te verbinden voor bidirectionele elektrische stroom, de zekeringhouder (1a)
verwijderbaar verbonden is, de thermische zekering (7) geschikt is om de functie van het
10 activeren van de uitschakel- en/of blusfunctie uit te voeren, en/of verder ten minste één
netwerkmodule (26) omvat voor het bewaken van de beveiligingsinrichting, en/of ten
minste één houder (10.. 1) voor het blusmiddelreservoir (5), waarbij het
blusmiddelreservoir (5) verwijderbaar is bevestigd aan de drager (10), en/of een vast of
verwijderbaar tussenschot (11) voor mechanische scheiding van contacten en/of een
15 temperatuurdetector.
2. Beveiligingsinrichting volgens conclusie 1, **gekenmerkt doordat** in het geval van
meerdere naast elkaar geplaatste beveiligingsinrichtingen, de afzonderlijke inrichtingen
worden gescheiden door een tussenschot.
20
3. Beveiligingsinrichting (1) volgens conclusie 1 en/of 2, **gekenmerkt doordat de**
thermische zekering (7) gemaakt is van materialen met een definieerbare
vervormingstemperatuur of een schroef is van polyamide of bimetaal.
- 25 4. Beveiligingsinrichting volgens conclusie 1, **gekenmerkt doordat** ten minste één
beveiligingsinrichting is verschaft in het schakelbord voor ten minste één fase.
5. Een schakelbordbewakingssysteem, **gekenmerkt doordat** het ten minste één
elektriciteitskast (25) bevat met daarin ten minste één beveiligingsinrichting volgens een
30 van de conclusies 1 tot en met 3, een netwerkmodule (26) en/of een brandblusser, verder
omvattende ten minste één verdeelkast (28), ten minste één zender/ontvanger (29), ten
minste één transformatorstation (30), waarbij de elektriciteitskast (25) via een kabel
verbonden is met de verdeelkast (28), de verdeelkasten (28) rechtstreeks of via een andere
verdeelkast (28) via een kabel verbonden zijn met het transformatorstation (30), en de

elektriciteitskasten (25) via een draadloos communicatienetwerk verbonden zijn met ten minste één zendontvanger (29) van de moederentiteit/object.

- 5 6. Systeem volgens conclusie 4, **gekenmerkt doordat** de netwerkmodule (26) een microcontroller (31), een testcontact (32) voor het aansluiten van een storingsindicatiebron, ten minste één temperatuursensor/detector (33), een regelinrichting (34), een voedingsbron (35), een radiocommunicatiemodule (36), communicator (27) en vermogensregeleenheid (37) omvat.
- 10 7. Systeem volgens conclusie 4 en/of 5, **gekenmerkt doordat** de netwerkmodule (26) zich in de elektriciteitskast (25) en/of in de beveiligingsinrichting bevindt.

[Fig. 1a]

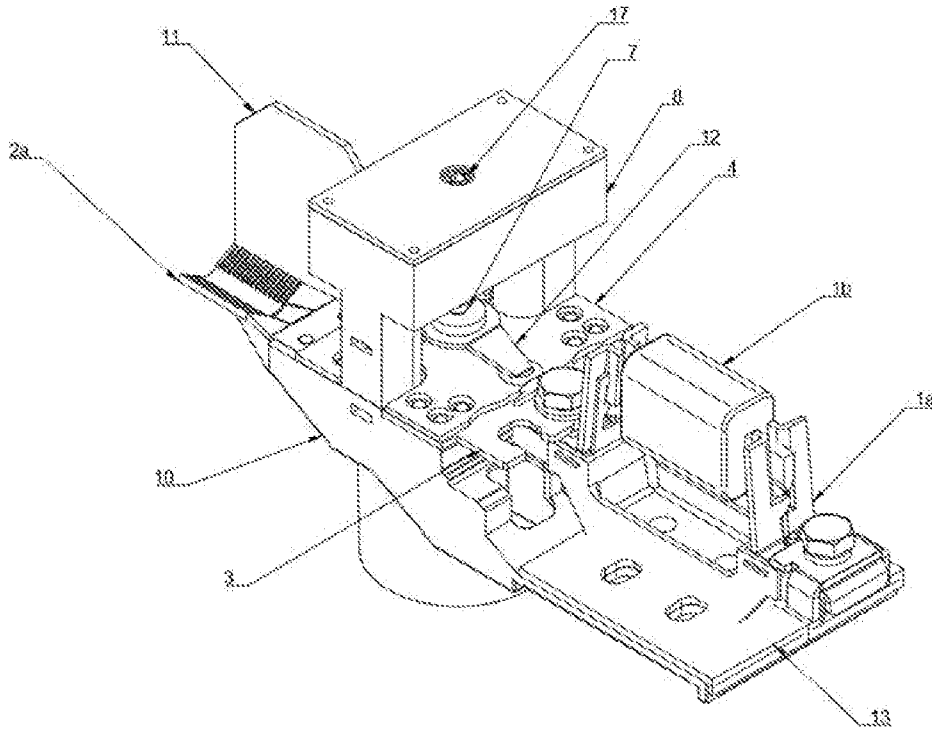

[Fig. 1b]

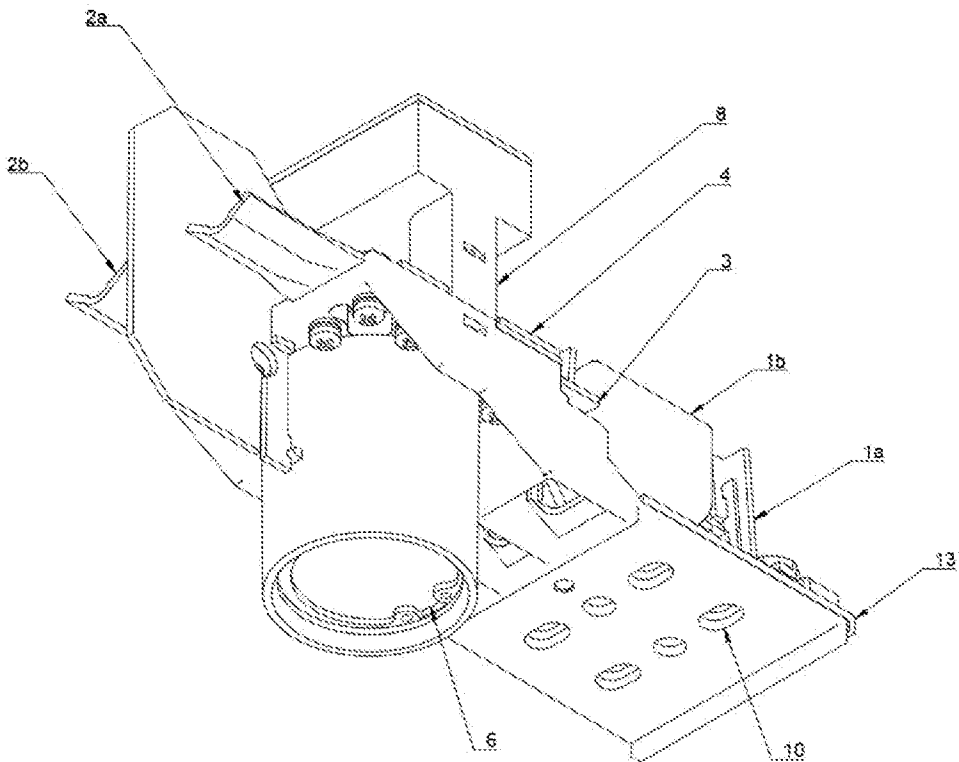

[Fig. 1c]

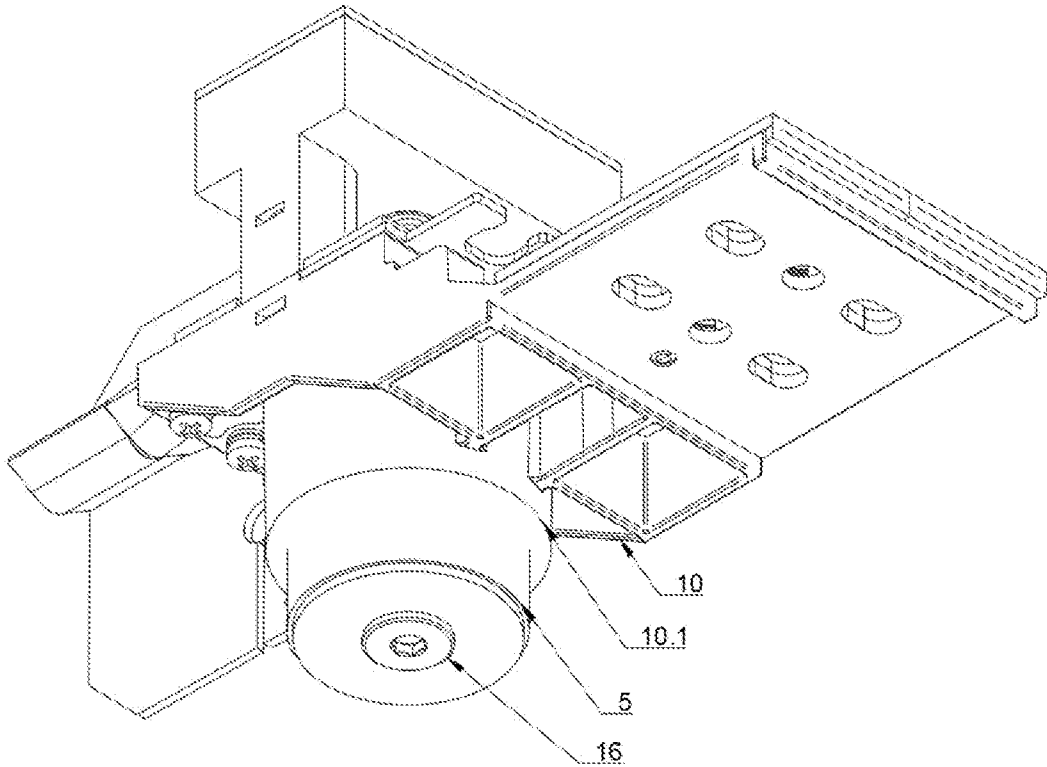

[Fig. 2]

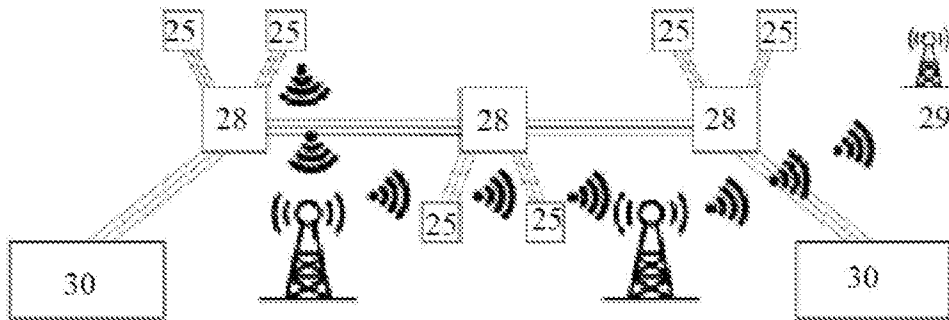

[Fig. 3]

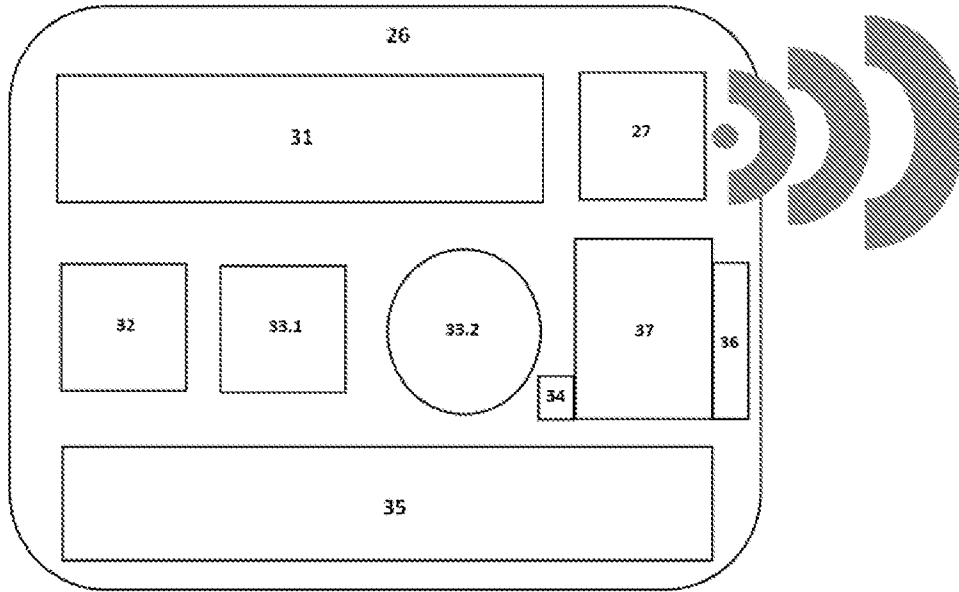

[Fig. 4]

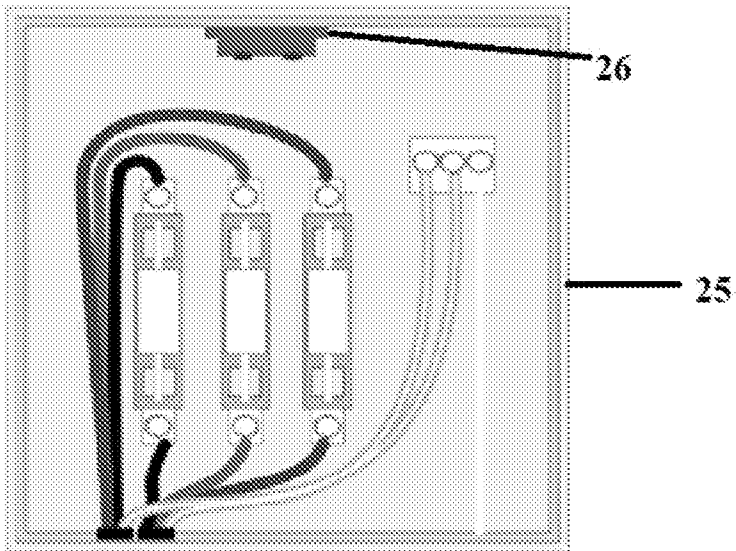

[Fig. 5]

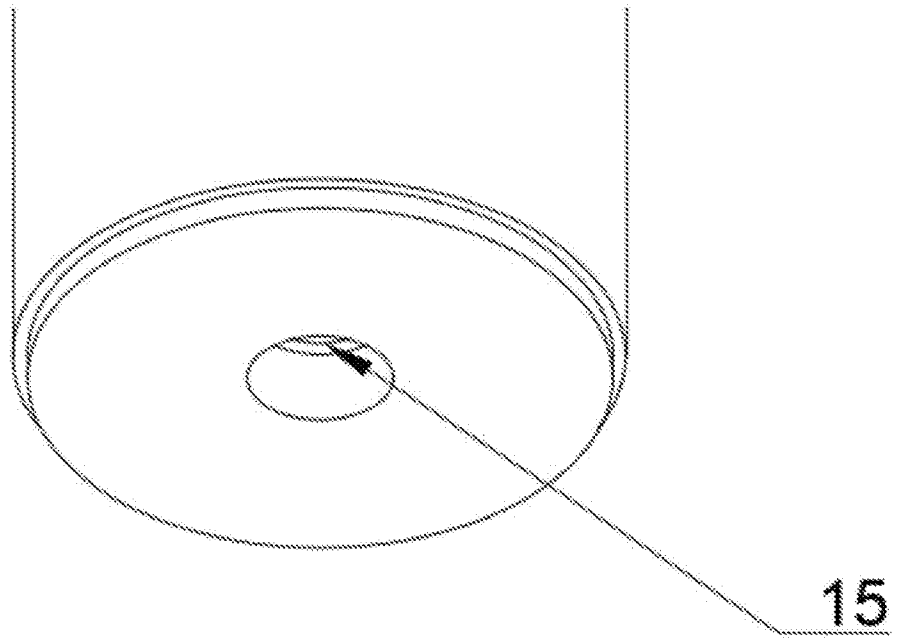

[Fig. 6]

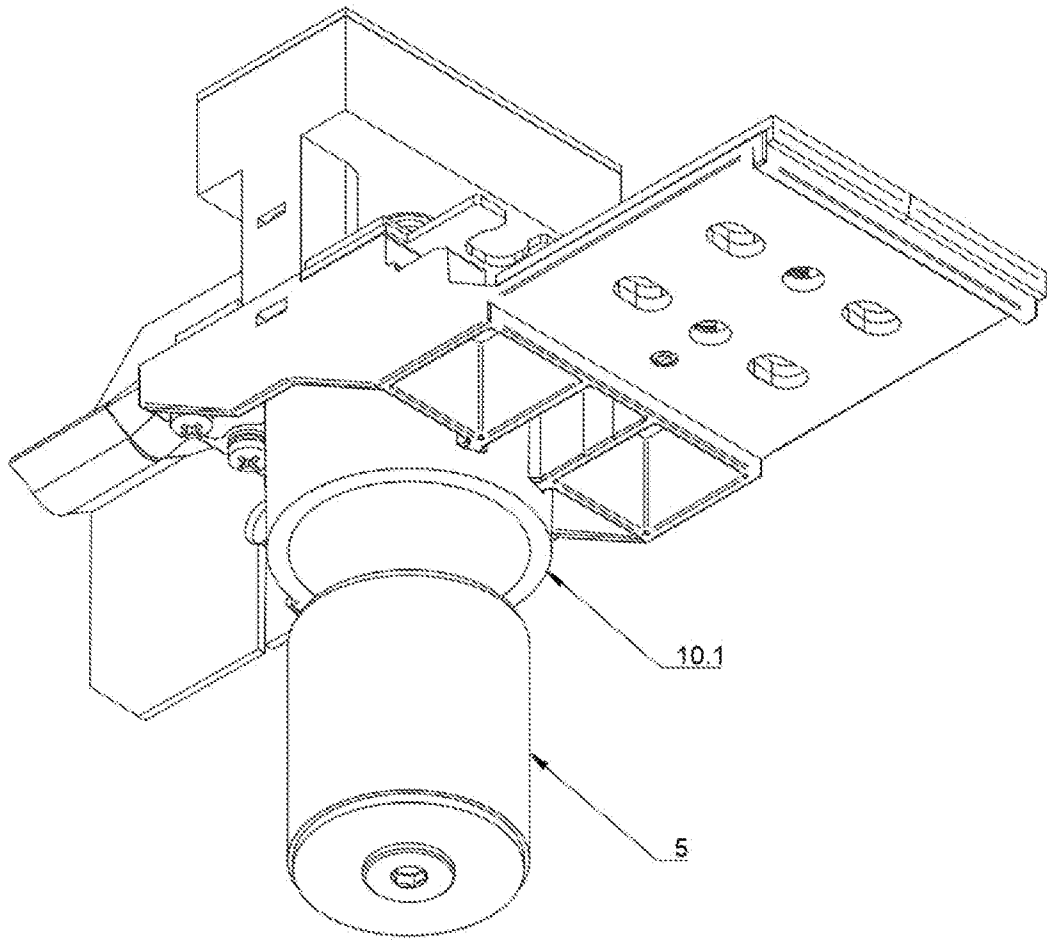

[Fig. 7]

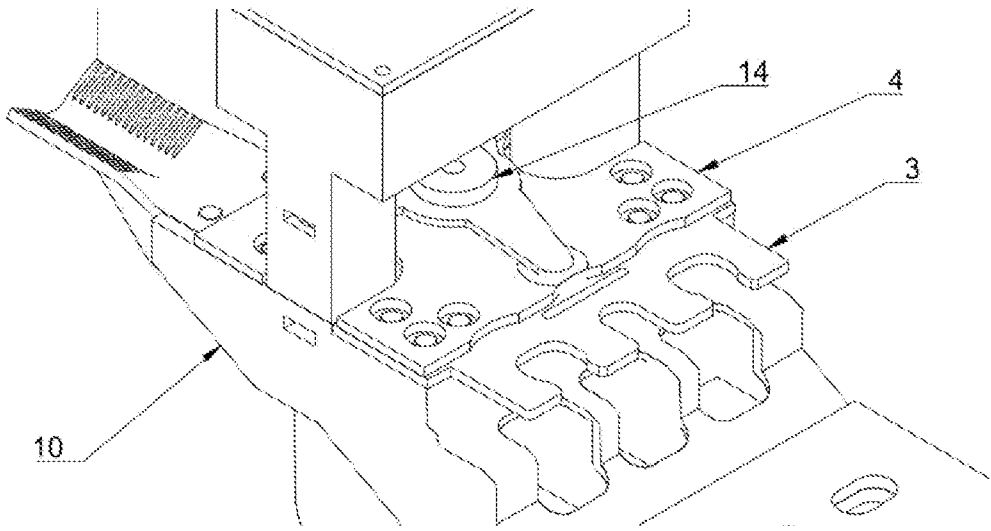

[Fig. 8]

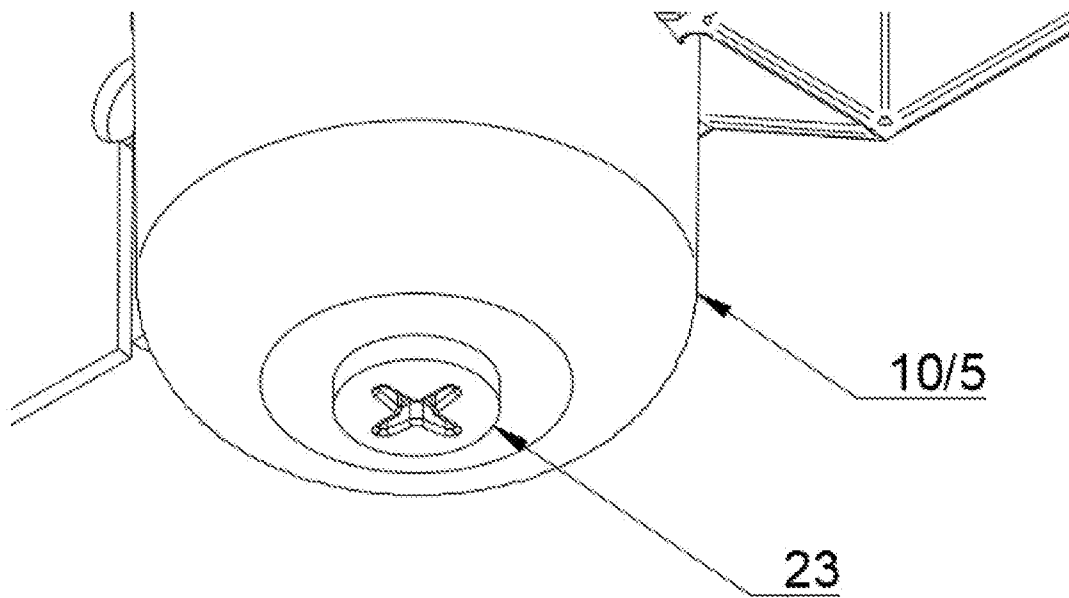

[Fig. 9]

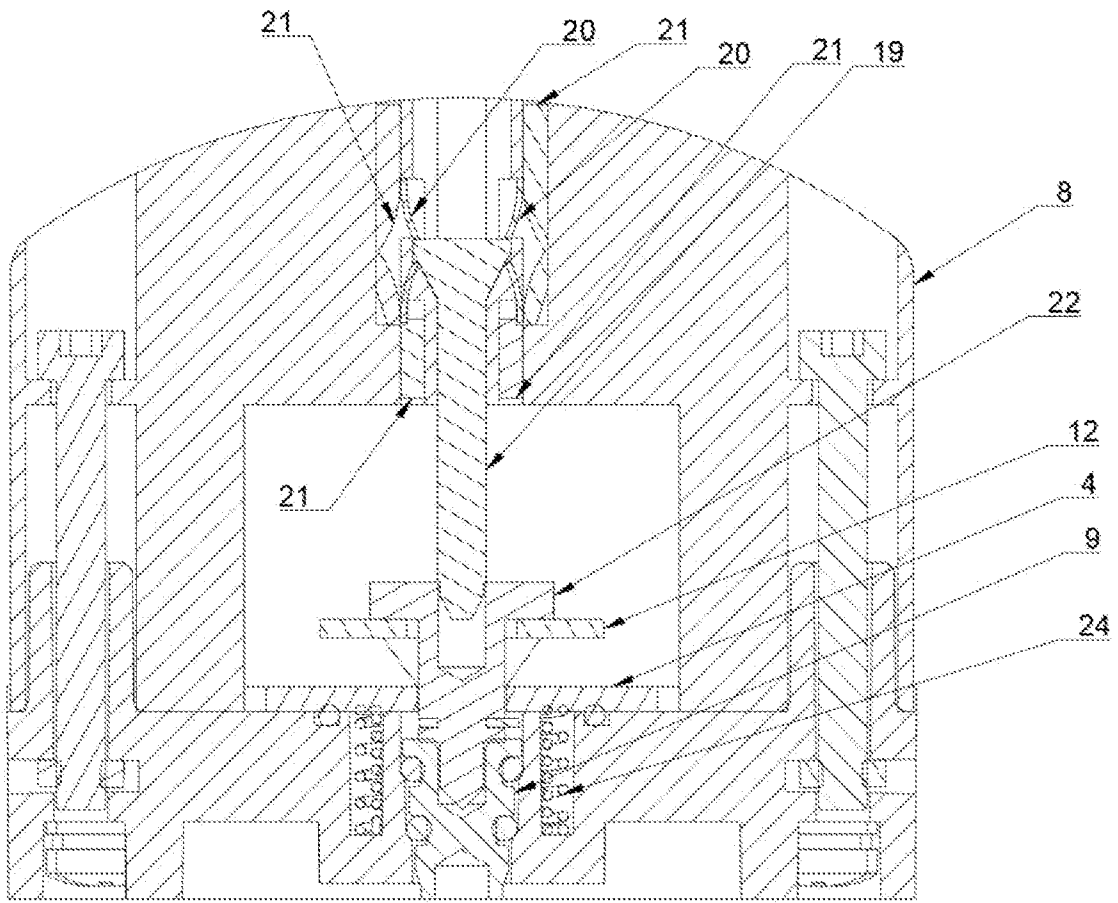

[Fig. 10]

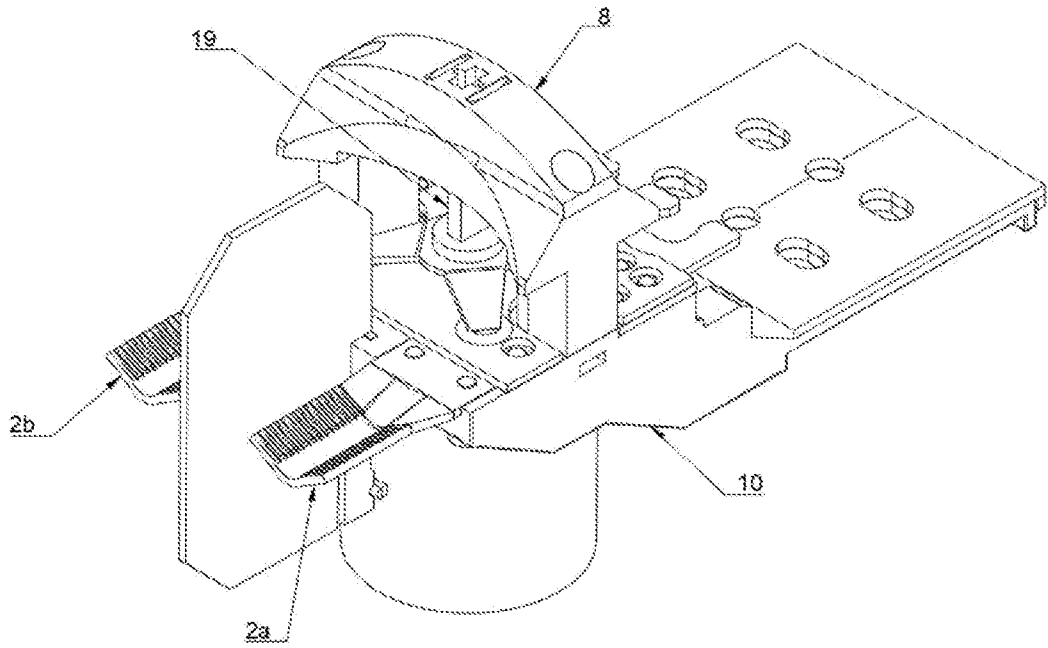

[Fig. 11]

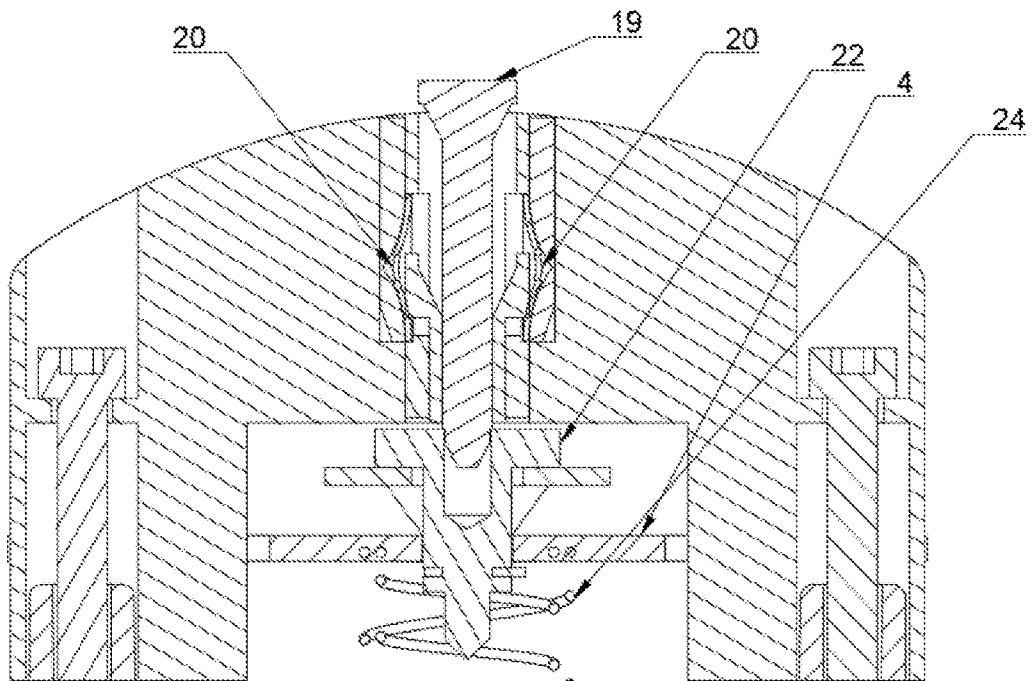

[Fig. 12]

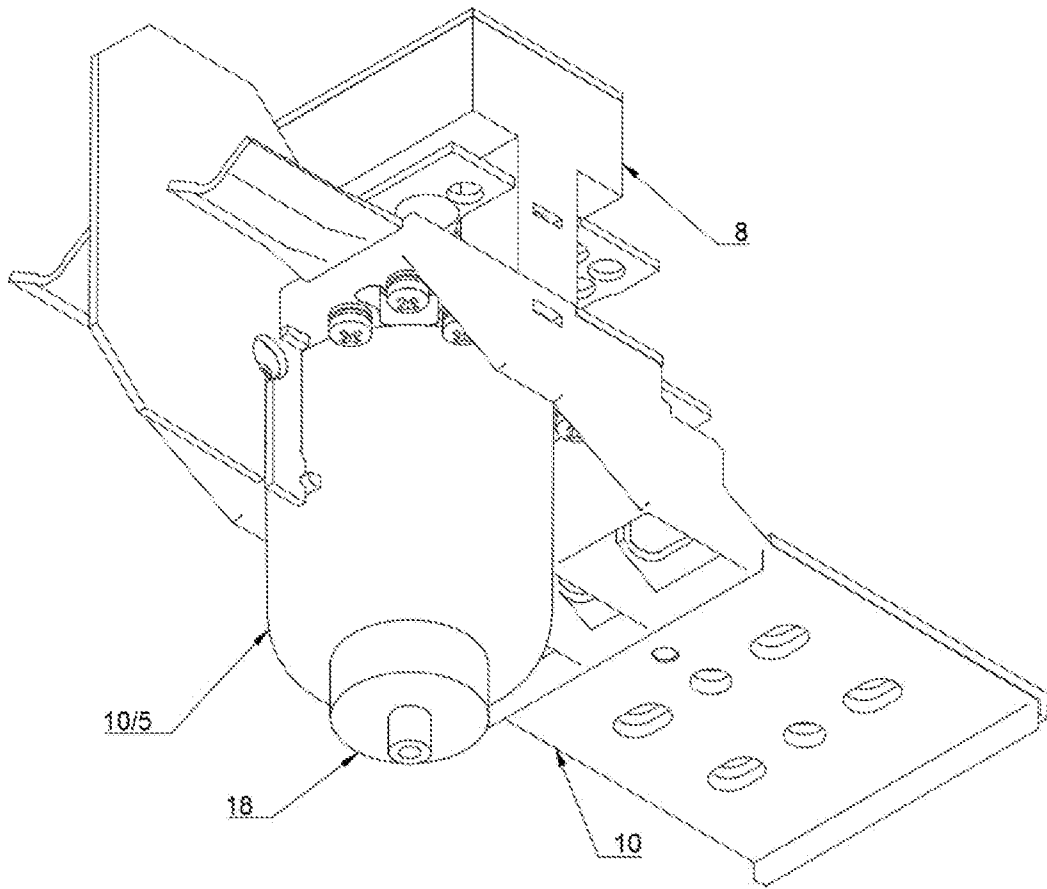

[Fig. 13]

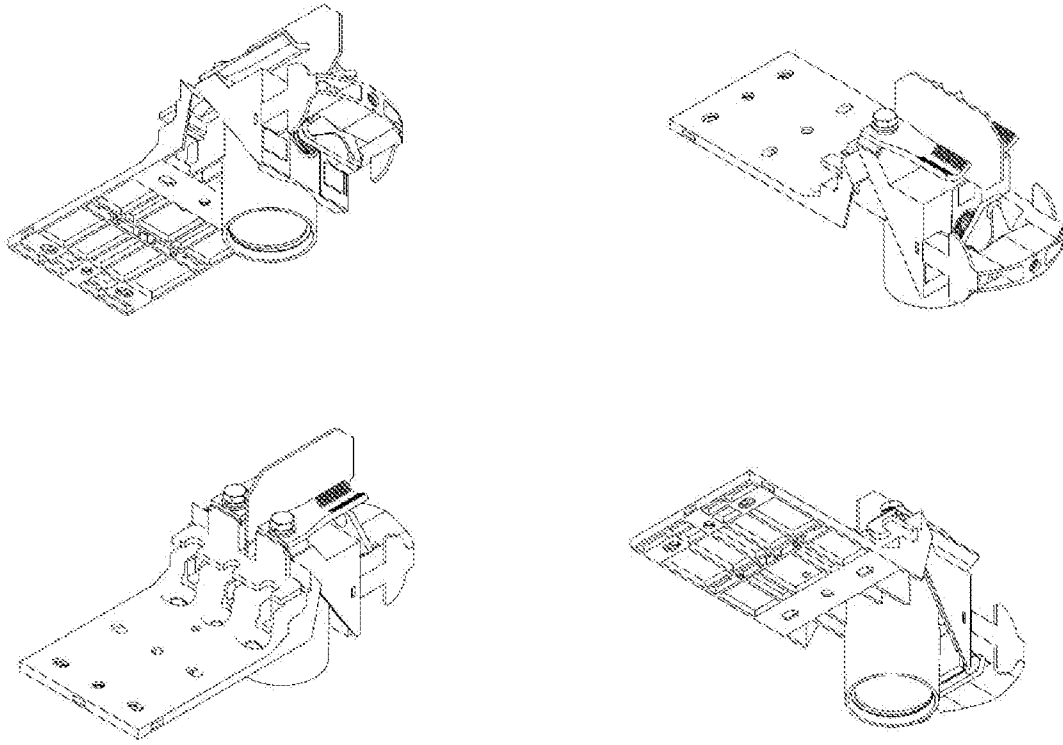

[Fig. 14]

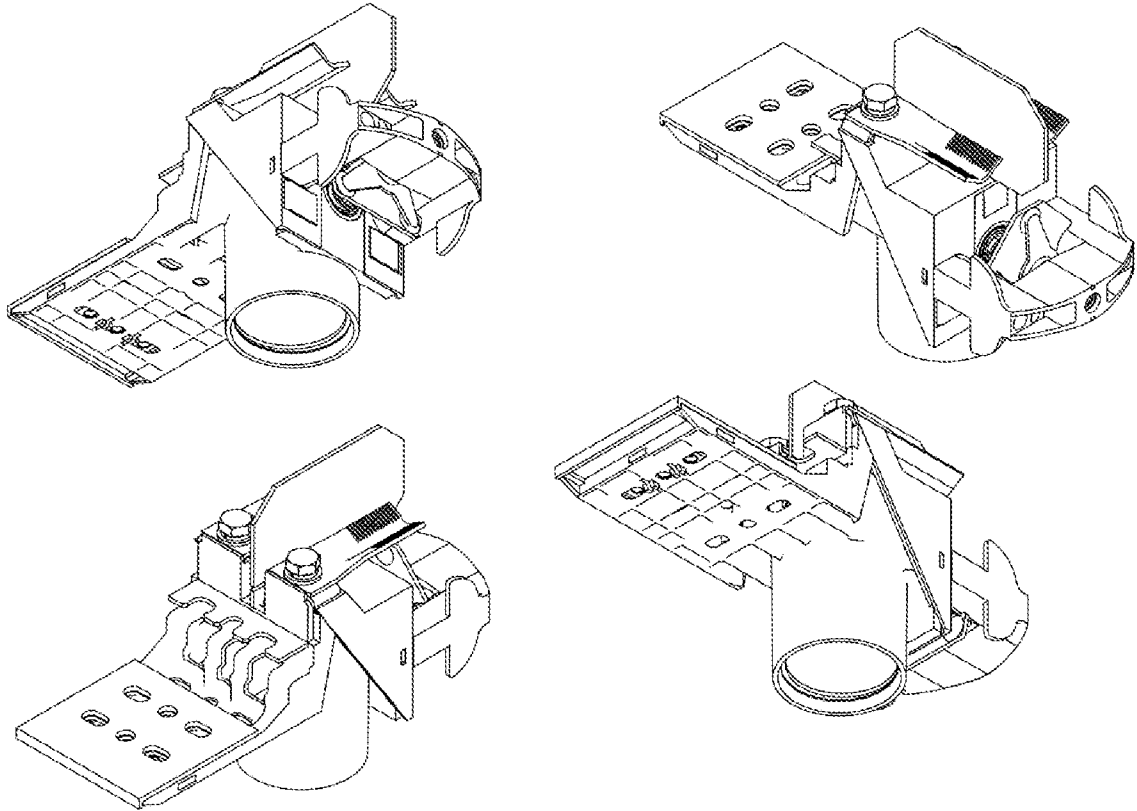

[Fig. 15a]

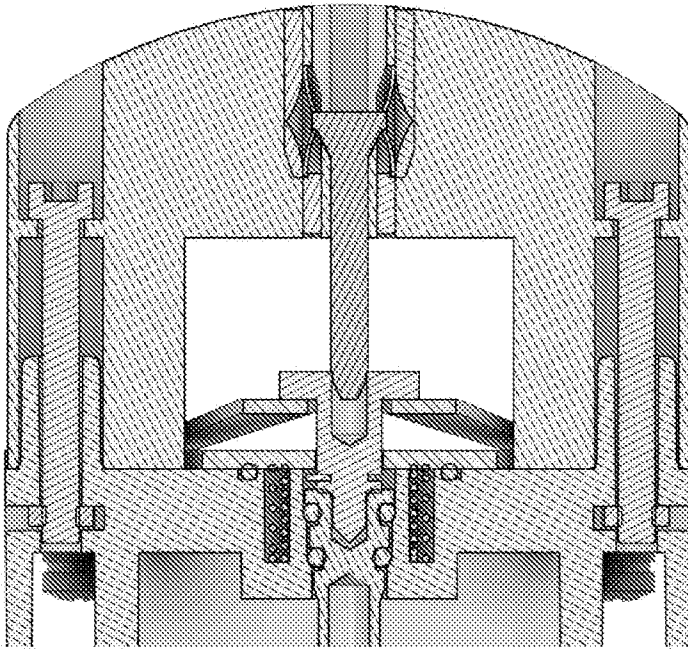

[Fig. 15b]



[Fig. 16]

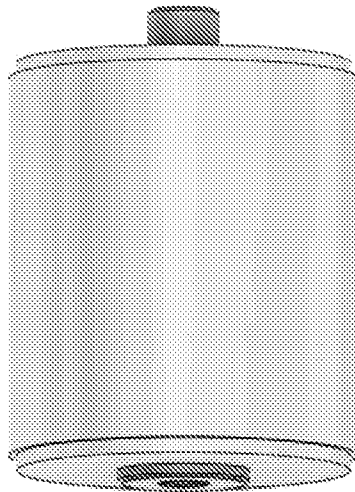
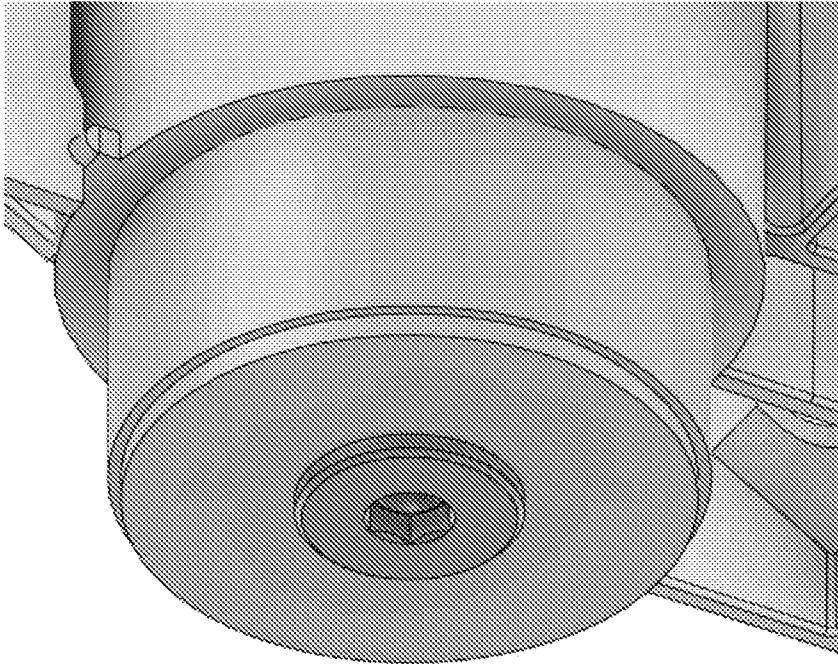

[Fig. 17]

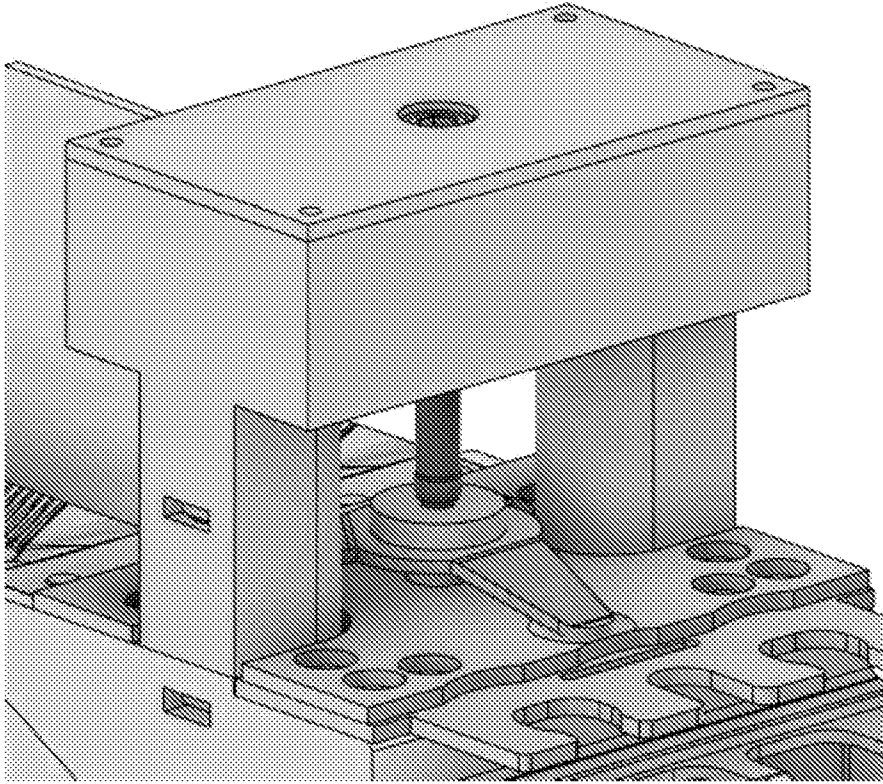

[Fig. 18]

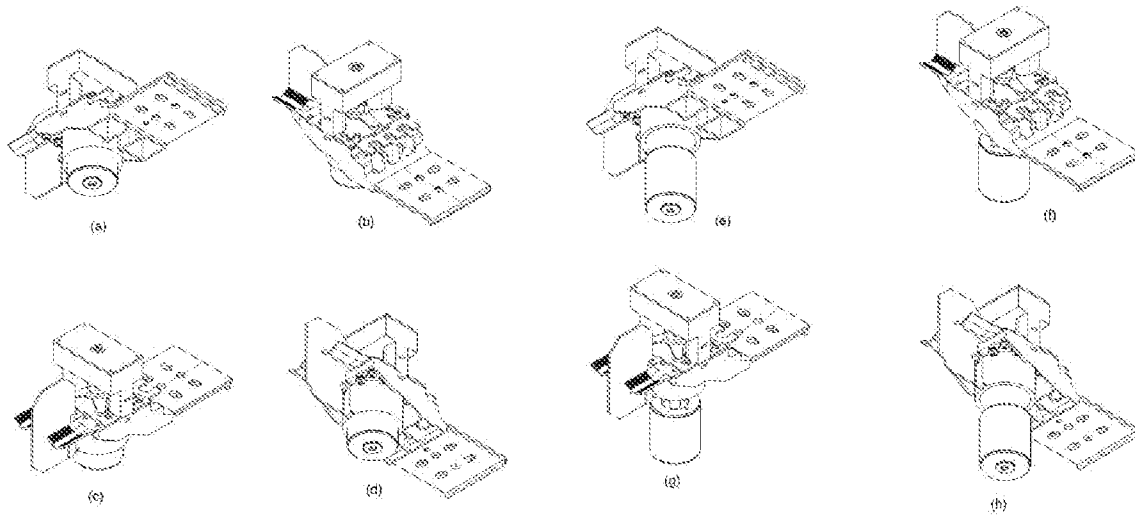

[Fig. 19]

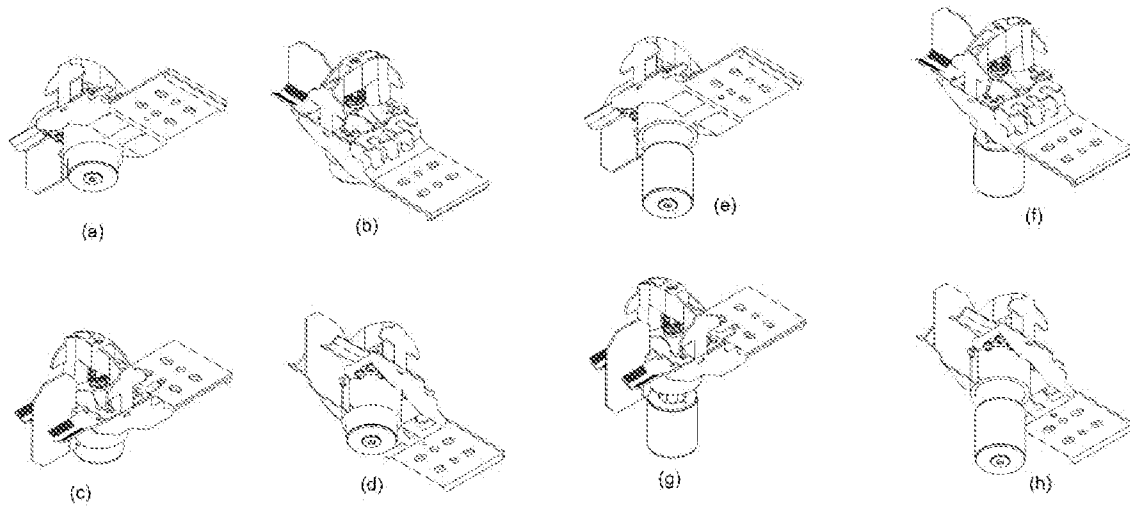

[Fig. 20]

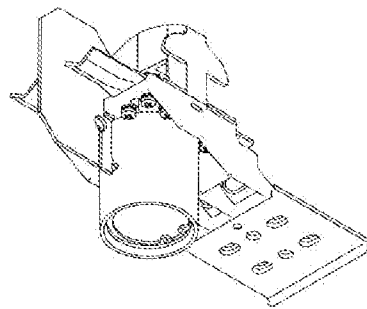
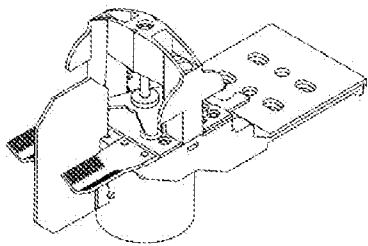
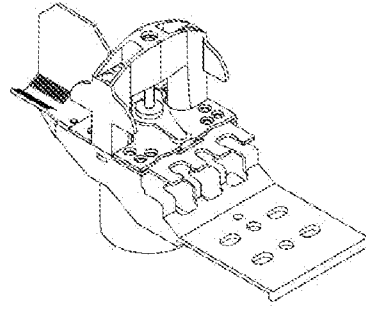
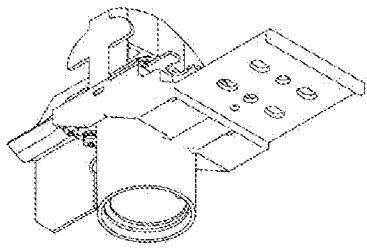

[Fig. 21]

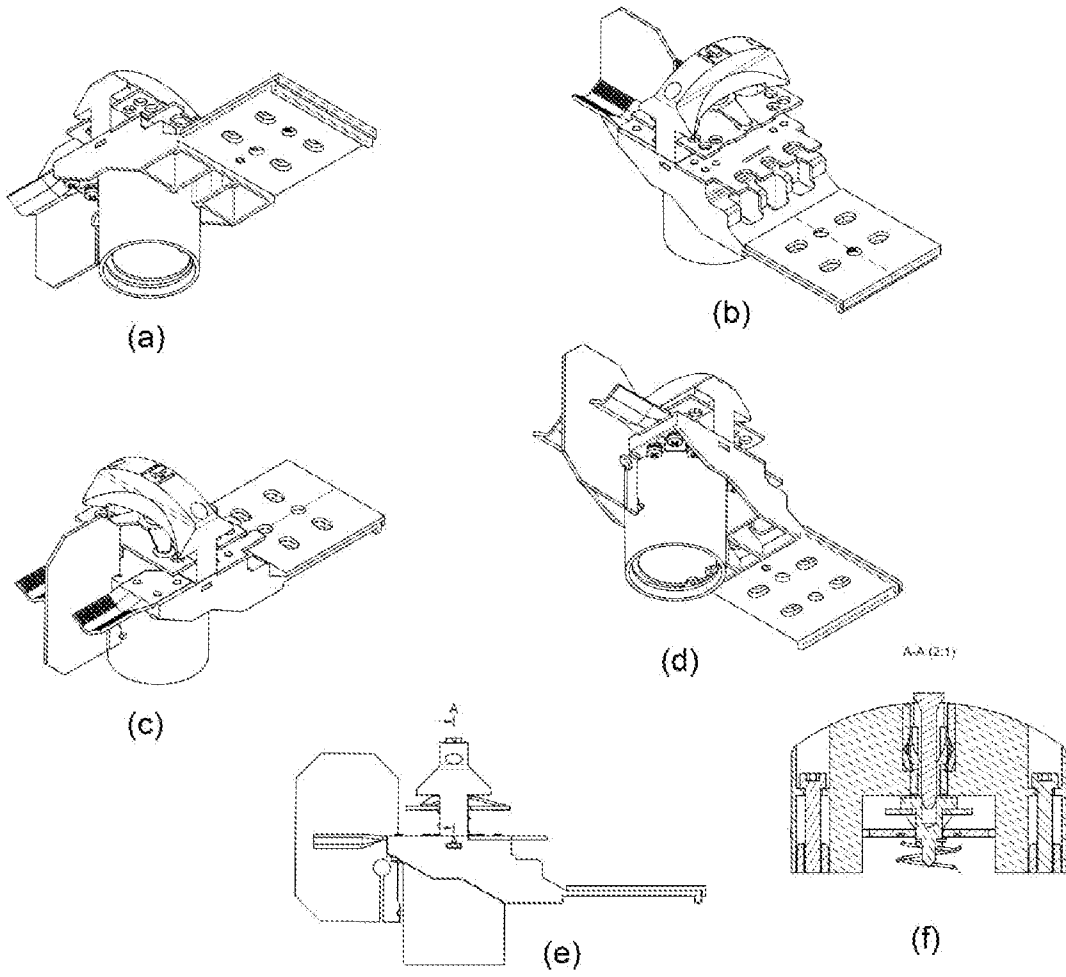

[Fig. 22]

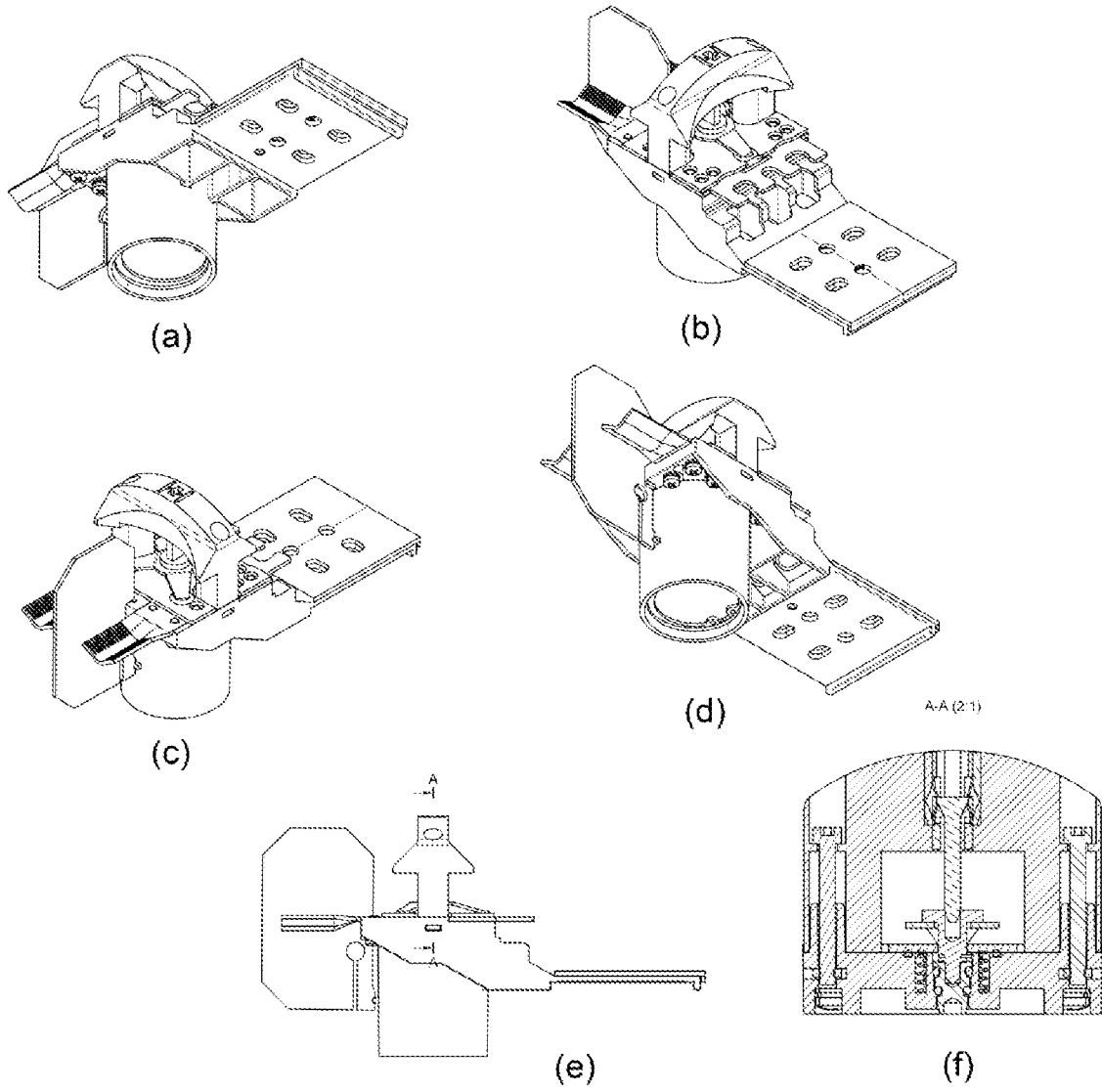

[Fig. 23]



[Fig. 24]

