



- (51) International Patent Classification:
G09B 23/34 (2006.01)
- (21) International Application Number:
PCT/US2012/060997
- (22) International Filing Date:
19 October 2012 (19.10.2012)
- (25) Filing Language: English
- (26) Publication Language: English
- (30) Priority Data:
61/549,838 21 October 2011 (21.10.2011) US
- (71) Applicant: **APPLIED MEDICAL RESOURCES CORPORATION** [US/US]; 22872 Avenida Empresa, Rancho Santa Margarita, CA 92688 (US).
- (72) Inventors: **HOKE, Adam**; Applied Medical Resources Corporation, 22872 Avenida Empresa, Rancho Santa Margarita, CA 92688 (US). **BRESLIN, Tracy**; Applied Medical Resources Corporation, 22872 Avenida Empresa, Rancho Santa Margarita, CA 92688 (US). **HART, Charles, C.**; Applied Medical Resources Corporation, 22872 Avenida Empresa, Rancho Santa Margarita, CA 92688 (US). **BOLANOS, Eduardo**; Applied Medical Resources Corporation, 22872 Avenida Empresa, Rancho Santa Margarita, CA 92688 (US).
- (74) Agent: **LUKAS, Rimas, T.**; Applied Medical Resources Corporation, 22872 Avenida Empresa, Rancho Santa Margarita, CA 92688 (US).

(81) Designated States (unless otherwise indicated, for every kind of national protection available): AE, AG, AL, AM, AO, AT, AU, AZ, BA, BB, BG, BH, BN, BR, BW, BY, BZ, CA, CH, CL, CN, CO, CR, CU, CZ, DE, DK, DM, DO, DZ, EC, EE, EG, ES, FI, GB, GD, GE, GH, GM, GT, HN, HR, HU, ID, IL, IN, IS, JP, KE, KG, KM, KN, KP, KR, KZ, LA, LC, LK, LR, LS, LT, LU, LY, MA, MD, ME, MG, MK, MN, MW, MX, MY, MZ, NA, NG, NI, NO, NZ, OM, PA, PE, PG, PH, PL, PT, QA, RO, RS, RU, RW, SC, SD, SE, SG, SK, SL, SM, ST, SV, SY, TH, TJ, TM, TN, TR, TT, TZ, UA, UG, US, UZ, VC, VN, ZA, ZM, ZW.

(84) Designated States (unless otherwise indicated, for every kind of regional protection available): ARIPO (BW, GH, GM, KE, LR, LS, MW, MZ, NA, RW, SD, SL, SZ, TZ, UG, ZM, ZW), Eurasian (AM, AZ, BY, KG, KZ, RU, TJ, TM), European (AL, AT, BE, BG, CH, CY, CZ, DE, DK, EE, ES, FI, FR, GB, GR, HR, HU, IE, IS, IT, LT, LU, LV, MC, MK, MT, NL, NO, PL, PT, RO, RS, SE, SI, SK, SM, TR), OAPI (BF, BJ, CF, CG, CI, CM, GA, GN, GQ, GW, ML, MR, NE, SN, TD, TG).

Published:

- with international search report (Art. 21(3))
- before the expiration of the time limit for amending the claims and to be republished in the event of receipt of amendments (Rule 48.2(h))



(54) Title: SIMULATED TISSUE STRUCTURE FOR SURGICAL TRAINING

(57) Abstract: A simulated tissue structure for practicing surgical techniques is provided. In particular, a realistic organ model or tissue portion for practicing the removal of a tumor or other undesired tissue followed by suturing a remnant defect as part of the same surgical procedure is provided. The simulated tissue structure includes an artificial tumor disposed between layers of elastomeric material and mounted on a simulated organ wall or tissue portion. The simulated tissue structure is modular and interchangeable. At least one of the layers includes a mesh reinforcement. A defect comprising two juxtapositioned surfaces defining a gap between the surfaces is created in the simulated tissue structure and the trainee practices tumor removal and closure of the gap by suturing in a laparoscopic environment.

SIMULATED TISSUE STRUCTURE FOR SURGICAL TRAINING

CROSS-REFERENCE TO RELATED APPLICATION

[0001] This application claims priority to and benefit of U.S. Provisional Patent Application Serial No. 61/549,838 entitled "Simulated tissue structure for surgical training" filed on October 21, 2011 which is incorporated herein by reference in its entirety.

FIELD

[0002] This application is generally related to surgical training tools, and in particular, to anatomical models simulating organs or tissue for teaching and practicing various surgical techniques and procedures.

BACKGROUND

[0003] Medical students as well as experienced doctors learning new surgical techniques must undergo extensive training before they are qualified to perform surgery on human patients. The training must teach proper techniques employing various medical devices for cutting, penetrating, clamping, grasping, stapling and suturing a variety of tissue types. The range of possibilities that a trainee may encounter is great. For example, different organs and patient anatomies and diseases are presented. The thickness and consistency of the various tissue layers will also vary from one part of the body to the next and from one patient to another. Accordingly, the skills required of the techniques and instruments will also vary. Furthermore, the trainee must practice techniques in readily accessible open surgical locations and in locations accessed laparoscopically.

[0004] Numerous teaching aids, trainers, simulators and model organs are available for one or more aspects of surgical training. However, there is a need for model organs or simulated tissue elements that are likely to be encountered in endoscopic, laparoscopic, transanal, minimally invasive or other surgical procedures that include the removal of tumors or other tissue structures. In particular, there is a need for realistic model organs for the repeatable practice of removing a tumor or other

undesired tissue followed by the closure of the target area by suturing or stapling as part of the same surgical procedure. In view of the above, it is an object of this invention to provide a surgical training device that realistically simulates such particular circumstances encountered during surgery.

SUMMARY

[0005] According to one aspect of the invention, a simulated tissue structure for surgical training is provided. The structure includes a defect layer located above the base layer. The defect layer includes at least one defect having two opposed surfaces that define at least one gap between the surfaces. A simulated tumor is located above the defect layer in such a way to overlay at least a portion of the defect. A cover layer is located above the base layer and overlays the tumor.

[0006] According to another aspect of the invention, a simulated tissue structure for surgical training is provided. The simulated tissue structure includes at least one simulated tissue module comprising a simulated tissue portion. The structure includes a module support having a first surface opposite from a second surface and defining a thickness therebetween. The module support includes at least one module receiving portion sized and configured to receive and connect with the at least one simulated tissue module. The simulated tissue module is insertable into and removable from the at least one module receiving portion and interchangeable with another simulated tissue module.

[0007] According to another aspect of the invention a method for surgical training is provided. The method includes the step of providing a simulated tissue structure comprising an artificial tumor located between a base layer and a cover layer. The base layer and the cover layer are made of elastomeric polymer that may include mesh reinforcement. The simulated tissue structure is placed inside a simulated body cavity of a surgical training device such that the simulated tissue structure is at least partially obscured from view by a user. The user removes the artificial tumor from the simulated tissue structure with instruments passed into the simulated body cavity with the simulated tissue structure obscured from the user and visualized on a video monitor providing a live feed of the simulated tissue structure inside the cavity via a laparoscope

or endoscope. At least one defect is created substantially in the location of the tumor. The defect comprises two adjacent surfaces defining a gap. The gap is closed by bringing the two adjacent surfaces together with instruments such as sutures, staples, adhesive or other surgical means. Suturing the gap to bring the two adjacent surfaces together. In one variation, creating a defect includes providing a defect layer in the simulated tissue structure. Providing a defect layer includes providing a defect layer with a pre-formed defect or gap and placing the defect layer such that the defect layer is between the base layer and the cover layer and at least a portion of the defect is located underneath the artificial tumor. In another variation, creating a defect includes cutting at least one of the base layer and cover layer. Removing the artificial tumor from the simulated tissue structure includes removing the artificial tumor through the defect created by cutting.

BRIEF DESCRIPTION OF THE DRAWINGS

[0008] FIG. 1 illustrates a side view of a surgical training device with a model organ according to the present invention.

[0009] FIG. 2A illustrates a side cross-sectional view of a simulated tissue structure according to the present invention.

[0010] FIG. 2B illustrates a side cross-sectional view of a simulated tissue structure with tumor excised according to the present invention.

[0011] FIG. 2C illustrates a side cross-sectional view of a simulated tissue structure with an open suture according to the present invention.

[0012] FIG. 2D illustrates a side cross-sectional view of a simulated tissue structure with a closed suture according to the present invention.

[0013] FIG. 3A illustrates a top view of a defect layer having a circular shaped defect according to the present invention.

[0014] FIG. 3B illustrates a top view of a defect layer having an elongated defect according to the present invention.

[0015] FIG. 3C illustrates a top view of a defect layer having an amorphous defect according to the present invention.

[0016] FIG. 3D illustrates a top view of a defect layer having a two-piece defect according to the present invention.

[0017] FIG. 3E illustrates a top view of a multi-part defect layer according to the present invention.

[0018] FIG. 3F illustrates a top view of a defect layer having multiple defects according to the present invention.

[0019] FIG. 4 illustrates a top view of a simulated tissue structure according to the present invention.

[0020] FIG. 5 illustrates a side cross-sectional view of a simulated tissue structure according to the present invention.

[0021] FIG. 6A illustrates a perspective view of a modular tissue structure and support according to the present invention.

[0022] FIG. 6B illustrates a perspective view of a modular tissue structure and support according to the present invention.

[0023] FIG. 7 illustrates a cross-sectional view of a simulated tissue structure configured to mimic a human uterus according to the present invention.

[0024] FIG. 8 illustrates a top view of a modular tissue structure according to the present invention.

[0025] FIG. 9 illustrates a side view of a modular tissue structure according to the present invention.

[0026] FIG. 10A illustrates a perspective view of a simulated tissue structure according to the present invention.

[0027] FIG. 10B illustrates a perspective view of a simulated tissue structure according to the present invention.

[0028] FIG. 11A illustrates a perspective view of a simulated tissue structure according to the present invention.

[0029] FIG. 11B illustrates a perspective view of a simulated tissue structure according to the present invention.

[0030] FIG. 12 illustrates a perspective view of a suture needle and a simulated tissue structure according to the present invention.

DETAILED DESCRIPTION

[0031] A surgical training device 10 that is configured to mimic the torso of a patient such as the abdominal region is shown in FIG. 1. The surgical training device 10 provides a simulated body cavity 18 substantially obscured from the user for receiving model organs or simulated or live tissue 20. The body cavity 18 is accessed via a tissue simulation region 19 that is penetrated by the user employing devices to practice surgical techniques on the tissue or organ 20 found located in the body cavity 18. Although the body cavity 18 is shown to be accessible through a tissue simulation region 19, a hand-assisted access device or single-site port device may be alternatively employed to access the body cavity 18 as described in U.S. Patent Application Serial No. 13/248,449 entitled "Portable Laparoscopic Trainer" filed on September 29, 2011 and incorporated herein by reference in its entirety. The surgical training device 10 is particularly well suited for practicing laparoscopic or other minimally invasive surgical procedures.

[0032] The surgical training device 10 includes a base 12 and a top cover 14 connected to and spaced apart from the base 12 to define an internal body cavity 18 between the top cover 14 and the base 12. At least one leg 16 interconnects and spaces apart the top cover 14 and base 12. A model organ or simulated tissue 20 is disposed within the body cavity 18. The model organ 20 shown in FIG. 1 is a partial colon or intestine that is shown suspended from the top cover 14 by tethers 22 and connected to at least one leg 24. The at least one leg 24 has an aperture (not shown) facing the internal cavity 20. The model colon 20 includes a tube 26 having a proximal end and a distal end. The proximal end of the tube 26 is interconnected with the aperture of the leg 16 such that the aperture provides an access port to the lumen of the tube 26. The access port and aperture is shown to be closed off in FIG. 1 with an access device 28 which in combination with a sealed distal end of the tube 26 provides a model organ 20 that is adapted for insufflation with fluid deliverable via an insufflation port 30. An optional insert 32 made of soft material such as silicone creates a realistic interface for the access port. The distal end of the tube 26 extends into the body cavity 18 and is suspended within the body cavity 18. The interior of the tube 26 of the simulated organ 20 is accessible via the access port of leg 24 or via the tissue

simulation region 19 or instrument insertion ports 34. An endoscopic camera inserted into the body cavity 18 or into the organ 20 via the access port generates a live image for display on a fold out video screen 36 shown in the closed position in FIG. 1.

Although the simulated organ 20 of FIG. 1 is ideal for practicing procedures related to transanal minimally invasive surgery, any simulated organ or tissue portion may be employed. One particular aspect of the organ 20 is at least one tumor or defect 38 is provided and connected to the organ. As shown in FIG. 1, the tumor 38 is connected to the wall of the organ tube 26.

[0033] Turning now to FIG. 2A there is shown a partial side cross-sectional view of a portion of a simulated organ 20 that includes the tumor 38. The simulated organ or tissue 20 includes a base layer or organ wall 40. The organ wall 40 is made from a material configured to mimic real live tissue such as silicone or other polymer and is dyed appropriately. One or more base layers 40 of varying thicknesses and colorations may be employed to comprise the entirety of the wall 40. In one variation, the organ wall 40 is rigid and made of polymeric material. Above the base layer 40 is a second layer or defect layer 42. The defect layer 42 is the same size or smaller than the base layer 40 forming a raised platform for the tumor 38. The defect layer 42 is connected to the base layer 40 by adhesive or other means known to one having ordinary skill in the art including being integrally formed with the base layer 40 as a single unit. The defect layer 42 is made of silicone and in one variation of the same color as the base layer 40 such that the defect layer 42 blends into the background of the base layer 40. The defect layer 42 includes at least one defect or gap 44. In one variation, the defect 44 is a pre-fabricated breach in the defect layer 42 that mimics an incision, gap or other void in real tissue resulting from a tear, cut, removal or other surgical procedure that requires surgical attention by way of suturing, stapling or the like to close the defect. Such a situation arises most often in the removal of a tumor 38 where surrounding tissue is also removed together with the tumor 38 to preventatively ensure the entirety of the tumor is excised leaving behind a remnant defect in the tissue. The defect 44 comprises two opposed sides or surfaces defining a gap therebetween. Although the adjacent sides or surfaces are shown to be vertical with respect to the base layer 40, the invention is not so limited and the juxtaposed surfaces or sides can

have any shape and, for example, be curved. The defect 44 can be any shape as will be discussed with respect to FIGs. 3A-3F.

[0034] Turning now to FIG. 3A, there is shown a top view of a defect layer 42 having a circular defect 44. A defect layer 42 with an elongated, oblong or elliptically shaped defect 44 is shown in the FIG. 3B. The defect 44 can be amorphous or any shape as shown in FIG. 3C. The defect layer 42 may be multi-part as shown in FIG. 3D wherein the defect layer 42 includes two or more adjacent defect layer pieces 42a, 42b juxtaposed to create at least one defect 44 therebetween. Another multi-part defect layer 42 is shown in FIG. 3E where a plurality of adjacent defect layer pieces 42a, 42b and 42c form one or more defects 44 therebetween. Of course, a defect layer 42 may include multiple defects 44a, 44b and 44c as shown in FIG. 3F. The defects 44 may all be the same or have different shapes as shown in FIG. 3F. The shape, thickness and size of the defect allow the surgeon trainee to practice suturing across defects of varying difficulty. In one variation, the defect layer 42 is not of equal thickness. Instead, the thickness of the defect layer 42 varies at the defect location 48 to increase the difficulty of suturing or closing the defect.

[0035] Referring back to FIG. 2A, a tumor 38 is located above the defect layer 42. The tumor 38 is preferably a different color from the base layer 40 or defect layer 42 or both such that it is readily identifiable by the trainee. Preferably, the tumor 38 is made of silicone or other polymer material and is red, black, blue or dark brown in color. In general, the tumor 38 is of a darker color than the base or defect layers 40, 42 or otherwise in contrast therewith when viewed through a scope. In one variation, the tumor 38 is connected to the defect layer 42 by adhesive or other means known to one of ordinary skill in the art. In another variation, the tumor 38 is not connected or attached to the defect layer 42 but is removably located thereon.

[0036] Still referencing FIG. 2A, the simulated tissue structure 20 includes a cover layer 46 located above the tumor 38. In one variation, the cover layer 46 overlays the tumor 38, defect layer 42 and the base layer 40. The cover layer 46 is preferably transparent or translucent in color and made of a polymer material such as silicone. In another variation, the cover layer 46 is the same color as the base layer 40 or defect layer 42. The cover layer 46 is at least as thick as the base layer 40 or defect layer 42

and in one variation is thinner than the defect layer 42 and in another variation is thinner than the base layer 40. The cover layer 46 is sized to cover the entire tumor 38 and defect layer 42 and is big enough to contact the base layer 40 in one variation. In another variation, the cover layer 46 is sized to cover the entire tumor 38 and contact the defect layer 40. The cover layer 46 is connected to the base layer 40, defect layer 42, tumor 38 or any more than one of the three layers by way of adhesive or other means known to one of ordinary skill in the art. In another variation, the cover layer 46 is smaller and connected to the defect layer 42 alone. In yet another variation, the cover layer 46 is connected to both the defect layer 42 and base layer 42 by adhesive or other means known to one of ordinary skill in the art. The cover layer 46 can be any shape or sized and be configured to provide a smooth surface to the surgeon instead of a layered surface to the artificial tumor location. The cover layer 46, tumor 38, defect layer 42 or base layer 40 includes surface texturing in one variation. Also, the cover layer 46 assists in keeping the tumor 38 and defect layer 42 sandwiched between the cover layer 46 and base layer 40 which is advantageous in a variation wherein the tumor 38 is not adhered to the defect layer 42. A top planar view of the base layer 40, defect layer 42, cover layer 46 and tumor 38 is shown in FIG. 4. In one variation, any one or more of the base layer 40, defect layer 42 and cover layer 46 is formed of silicone molded over a woven, fabric, or mesh material such as nylon or cheesecloth so that the silicone layer has an integrated mesh structural support or other type of reinforcement. Any one or more of the layers 38, 40, 42, 46 can include a fabric or mesh reinforcement combined with an elastic polymer such as silicone. The mesh support aids in preventing the suture, staple, or suture needle from tearing through at least one of layers and especially the defect layer 42 when the suture is pulled to close the gap 44.

[0037] In FIG. 2B, the tumor 38 and a portion of the cover layer 46 are shown excised from the base layer 40. The excision is performed by the trainee using a surgical instrument such as a scalpel or other medical instrument to remove the tumor 38. The trainee will cut through the cover layer 46 around the tumor 38, isolate the tumor 38, lift and remove the tumor 38 away from the site to expose the underlying defect 44 as shown in FIG. 2B. Then, as shown in FIG. 2C the trainee sutures the

defect 44 using a surgical suture 48 bringing the lips or edges of the defect layer 42 together as shown in FIG. 2D, thereby, practicing the closing of a gap or wound created by the surgical removal of a tumor 38. Cutting the at least one layer to create an opening and removing the artificial tumor and suturing the gap is performed while the simulated tissue structure is disposed inside a simulated body cavity 18 of a surgical training device such that the simulated tissue structure is at least partially obscured from view by the user.

[0038] Turning now to FIG. 5, there is shown another variation in which there is no pre-formed gap or defect in the second or defect layer 42. Instead, upon excising the tumor 38, the defect is created by the user in one or more of the cover layer 46, defect layer 42, base layer 40 and any remaining tumor portion not removed by the user. The user would then practice suturing the created defect in any of these layers 38, 40, 42, 46. In one such variation, one of the defect layer 42 or base layer 40 is omitted from the construct. In another variation, the tumor 38 is located on a base layer 40 and the defect layer 42 is placed over the tumor 38 such that the defect layer 42 is above the tumor 38. In such a variation, a cover layer 46 may or may not be included. If a cover layer 46 is included it may be integrally formed together with the defect layer as a separate unitary layer. In any of the constructs described above with respect to FIGs. 2-5, the constructs may be flipped upside down or otherwise the layers placed in reverse or otherwise the construct being approachable by the user from either the top or bottom direction with the thicknesses and colors of the layers being adjusted accordingly if necessary to provide the simulated effects of real tissue.

[0039] Turning now to FIGs. 6A and 6B, in any of the variations in this description, the simulated tissue construct can be modular such that it is not integrally formed with the entire simulated organ 20 but instead configured as a module 50 that is removable and interchangeable. One or more modules 50 are supported or contained in a module support 52. A module support 52 includes a first surface 51, a second surface 53 and one or more tumor module receiving portions 54, 56, 58 formed in the support 52. The tumor support 52 can be rigid or pliable and made of polymeric material. The tumor support 52 may also comprise a sheet of elastomeric material. The module receiving portions 54, 56, 58 are each sized and configured to receive a

correspondingly sized and configured module 50. The modules 50 and module receiving portions 54, 56, 48 in FIG. 6 are shown to be circular; however, the tumor module 50 can be any shape with a complementary shaped receiving portion formed in the module support 52. The thickness of the support 52 can vary providing the construct with varying depths of tumor module 50 positioning. The module receiving portions 54, 56, 58 may include bottom walls onto which the tumor modules 50 may rest. Alternatively, the tumor receiving portions 54, 56, 58 extend between openings in the first surface 51 and the second surface 53 with the modules 50 with tumor 38 being connected between or at one of the openings at either surface 51, 53 or suspended within the tumor receiving portion. In one variation, a single tumor module 50 includes one or more tumors 38. The module support 52 is loaded with one or more tumor modules 50 and the simulated tissue construct 20 is inserted into the body cavity 18 of the surgical training device 10, framework or other torso model. It can be placed on the base 12 of the training device 10 or suspended within the body cavity 18 of the training device 10. The simulated tissue construct 20 and/or training device is fashioned with attachment mechanisms such as clips, fasteners, wires, hook-and-loop type fasteners and the like for placement, suspension or connection of the simulated tissue construct 20 to a training device 10.

[0040] With particular reference to FIG. 6B, there is shown a module support 52 that includes more than one layer. The module support 52 of FIG. 6B includes a first layer 57 connected to a second layer 55. In one variation, the first layer 57 is made of a sheet of elastomeric material and the second layer 55 is made of any suitable polymeric material such as low-density elastomeric foam. The second layer 55 serves as a support for the first layer 57. The second layer 55 also advantageously provides depth to the module support 52 permitting the tumors 38 within the modules 50 to be placed deeply into the module support 52 relative to the first surface 51. Module receiving portions 54, 56, 58 are formed in one or more than one of the first layer 57 and the second layer 55. Module receiving portions 54, 56, 58 formed in the second layer 55 may have a different shape than the shape the same module receiving portion 54, 56, 58 has in the first layer 57. In one variation, the tumor module 50 comprises at least only the simulated tumor 38 which is embedded or buried inside the second layer 55

with at least one of the first layer 57 or second layer 55 constituting a defect layer which the user can practice closing. As an alternative, the first layer 57 does not include a module receiving portion but instead the first layer 57 serves as a cover layer which the user practices cutting through to access the tumor 38 located in a tumor receiving portion formed in the second layer 55. In such variation, the first layer 57 can be a sheet of elastomeric material such as silicone and the second layer 55 is a layer of low-density elastomeric foam. The module support 52 is planar as shown in FIGs. 6A and 6B or, alternatively, shaped to mimic a portion of the human anatomy, tissue or organ.

[0041] For example, FIG. 7 illustrates a support 52 that is shaped to mimic a human uterus. The support 52 includes a first layer 57 connected to a second layer 55. In one variation, the first layer 57 is made of any suitable polymeric material such as a sheet of elastomeric material and the second layer 55 is made of any suitable polymeric material such as a low-density elastomeric foam. The second layer 55 serves as a support for the first layer 57 and advantageously permits the tumors 38 within the modules 50 or the tumors 38 by themselves to be connected to the support 52 and realistically extend deeply into the support 52 and be dispersed throughout the support 52 in various locations and orientations including being embedded into the first layer 57 as shown in FIG. 7. Tumor or module receiving portions 61 are formed in at least one of the first layer 57 and second layer 55. The tumor receiving portions 61 may be pockets that are preformed in the second layer 55 or can be formed by the user by cutting slits into the second layer 55. In one variation, the tumors 38 are configured to mimic fibroid tumors commonly found in the human uterus. Examples of fibroid tumors that are simulated by the tumors 38 disposed in the support include but are not limited to one or more of the following types of fibroids: pedunculated submucosal fibroids, subserosal fibroids, submucosal fibroids, pedunculated subserosal fibroids and intramural fibroids. The user can approach the support 52 to excise the simulated tumors 38 from the first surface 51 or the second surface 53 via the access channel or opening 63. In one variation, the opening 63 serves as the only opening to the hollow portion 59 or alternatively the support 52 can have a substantially C-shaped planar configuration with access available to the user from above or below the planar C-shaped structure.

[0042] In one variation, the module support 52 in any of the variations is not planar but is provided with a landscape that includes curves and other structures, mountains and valleys and various textures. The varying landscape provides the user with various levels of difficulty in approaching each tumor location requiring the user to navigate around artifacts and features that may obscure the tumor location. These structural artifacts in the tumor support 52 may be integrally formed with the tumor support 52 or also be modular in structure similar to the tumor modules 50 making the anatomy landscape modules removable and interchangeable. Tumor modules 50 are interchangeable with non-tumor modules that include, for example, features and artifacts or textures made of silicone or other material extending outwardly or inwardly from the one or more of the upper and lower surfaces 51, 53 of the module support 52. The features in such non-tumor modules can have various shapes to mimic anatomy that includes adjacent organ structures or tissues. For example, a non-tumor module can include a tubular form of silicone to mimic an intestine. The non-tumor and tumor modules 50 are removably connected to the module support 52 by any means known to one skilled in the art enabling the user to discard a module after use and then to continue practicing by replacing the discarded module or moving to an adjacent module 50 in the module support 52 or changing out a tumor module 50 for another tumor module 50 having a different feature or level of difficulty.

[0043] A variation of the tumor module 50 is shown in FIGs. 8 and 9. The tumor module 50 includes a simulated tissue portion 60 connected to a support 62. In the variation shown, the support 62 includes a top frame 64 connected to a bottom frame 66. At least one of the top frame 64 and bottom frame 66 includes a window. The top frame 64 having a window 68 is shown in FIG. 8. The bottom frame 66 may or may not include a window. If windows are provided in both the top frame 64 and the bottom frame 66, the windows are aligned at least in part. The support 62 is sized and configured to receive a simulated tissue portion 60 between the top frame 64 and the bottom frame 66. The top frame 64 is connectable to the bottom frame 66 to capture the unitary simulated tissue portion 60 or a simulated tissue portion 60 formed from multiple layers and, in one variation, separable. In one variation, the frames 64, 66 are spaced apart from each other using spacers 70. Furthermore, at least one of the top

and bottom frames 64, 66 includes one or more connecting features 72 configured to secure the tumor module 50 to a tumor support 52 (not shown). In FIG. 9, the connecting features 72 are shown as extending pegs for insertion into corresponding holes formed in the tumor support 52 to provide a snap-fit engagement. A friction fit or other fasteners or connecting means such as hook-and-loop type materials can be employed on the module 50 and module support 52 to connect the module 50 to the support 52 in a removable fashion.

[0044] Still referencing FIGs. 8 and 9, the simulated tissue portion 60 can be any of the constructs described above with reference to FIGs. 2-5. With windows formed in both the first and second frames 64, 66, the simulated tissue portion 60 can be approached from either side of the module 50. Any layer described above as a cover layer may act as a top layer or as a bottom layer depending on from which side or direction the simulated tissue portion 60 is approached. For example, a base layer may also serve as a top layer or as a bottom layer depending on which side or direction the simulated tissue portion 60 is approached. In such, bi-directional constructs, the thicknesses and colors of the layers may be adjusted accordingly to provide the desired simulated effect.

[0045] The simulated tissue portion 60 in FIG. 9 includes a first layer 74 and a second layer 76. The first and second layers 74, 76 are made from a polymeric material configured to mimic real live tissue such as silicone or other polymer and can include dye of any one or more appropriate colors or mesh, fabric, or other reinforcement. Each of the layers 74, 76 includes a tumor receiving portion 78, 80, respectively. Each tumor receiving portion 78, 80 is a concavity, indent, half-pocket or a location of reduced layer thickness that is formed in the layers 74, 76. The tumor receiving portions 78, 80 are substantially aligned to form a pocket for the tumor 38. Although each layer 74, 76 in FIG. 9 is shown with a tumor receiving portion 78, 80, a single tumor receiving portion is formed in at least one of the first and second layers 74, 76 in one variation. A tumor 38 is disposed within the pocket formed by one or more tumor receiving portions 78, 80 formed in the one or more layers 74, 76. The tumor 38 may be adhered to either layer 74, 76 or free floating inside the pocket. As shown in FIG. 9, the tumor receiving portion formed in a layer can be considered to be one type of defect and the variation of FIG. 9

describes a simulated tissue construct comprising two defect layers with a tumor therebetween. As a user approaches the simulated tissue portion 60, the user will see the target tumor location. Visualization of the target tumor 38 is enhanced by the tumor receiving portion being thinner in thickness relative to the rest of the layer with the thinning of the layer being provided by the concavity or pocket. The user will then cut in the general location of the tumor cutting into at least one of the layers 74, 76 to remove the tumor 38. Cutting through one or more layers completes the creation of a gap or full defect which the user can then practice suturing or otherwise closing together. In another variation, there is no tumor receiving portion formed in the layers 74, 76. In such a variation, at least one tumor is disposed between the two layers 74, 76 wherein the layers 74, 76 have a substantially uniform thickness with the tumor 38 creating a minor bulge in the layers.

[0046] Turning now to FIGs. 10A, 10B, 11A, 11B and 12, there is shown another variation of a simulated tissue portion 86. The tissue portion 86 can be integral or modular as described above. The tissue portion 86 includes a base layer 88 formed of any suitable polymeric material such as silicone or other elastomeric polymer that may or may not include a reinforcement material such as fabric, mesh, nylon or other reinforcement material or filler that will resist tearing while carrying sutures or while being sutured. The base layer 88 is connected to a defect layer 90 that is overlaid onto the base layer 88. The defect layer 90 includes a plurality of protrusions extending upwardly from the base layer 88. The defect layer 90 may be integrally formed with the base layer 88 or be a separate layer that is adhered to the base layer 88. As can be seen in FIGs. 10A, 11A and 12, the defect layer 90 is configured into a lattice shaped pattern such that the lattice is raised above the base layer 88 or projects upwardly from the base layer 88. A lattice pattern is exemplary and any shape may be formed by the defect layer 90 such that it contains a plurality of adjacent projections. These projections of the base layer 90 provide the user with locations to hook a suture needle into and as a platform to raise the tumor 38a, 38b above the base layer 88 for easy excision. The tumors 38a, 38b may be adhered to the defect layer 90 and a cover layer 92 may be included in one variation. FIGs. 10A and 11A show the base layer 88, defect layer 90, tumors 38a, 38b and a cover layer 92 in a semi-exploded view of the simulated

tissue portion 86 wherein the cover layer 92 is raised above the other layers. The tumor 38a of FIG. 10a is substantially planar and is shown covered in FIG. 10B by the cover layer 92. Tumor 38b of FIG. 11A has greater height and is substantially spherical in shape and FIG. 11B shows the spherical tumor 38b covered with the cover layer 92 leaving a raised portion or protuberance in the construct. FIG. 12 shows the tumor 38 being removed leaving a remnant defect 94 in the base layer 88 and a suture needle crossing the gap in the defect 94 with the defect having been accessed under or through the cover layer 92.

[0047] While certain embodiments have been particularly shown and described with reference to exemplary embodiments thereof, it will be understood by those of ordinary skill in the art that various changes in form and details may be made therein without departing from the spirit and scope thereof as defined by the following claims.

CLAIMS

We claim:

1. A simulated tissue structure for surgical training, comprising:
a base layer;
a defect layer located above and connected to the base layer, the defect layer including at least one defect defining at least one gap;
a simulated tumor located above the defect layer and overlaying at least a portion of the defect; and
a cover layer located above the base layer and overlaying the tumor.
2. The simulated tissue structure of claim 1 wherein the defect layer includes a plurality of protrusions extending from the base layer.
3. The simulated tissue structure of claim 1 wherein the thickness of the defect layer varies.
4. The simulated tissue structure of claim 1 wherein the defect layer includes multiple defects.
5. The simulated tissue structure of claim 1 wherein the defect layer comprises two or more juxtaposed pieces.
6. The simulated tissue structure of claim 1 wherein the cover layer is transparent or translucent.
7. The simulated tissue structure of claim 1 wherein the cover layer overlays the tumor and defect layer.
8. The simulated tissue structure of claim 1 wherein the defect includes two juxtapositioned surfaces defining the at least one gap therebetween.

9. The simulated tissue structure of claim 1 wherein the base layer is tubular in shape.

10. The simulated tissue structure of claim 1 wherein at least one of the base layer, defect layer and cover layer includes a mesh material.

11. A simulated tissue structure for surgical training, comprising:
at least one simulated tissue module comprising a simulated tissue portion; and
a module support having a first surface opposite from a second surface and defining a thickness therebetween; the module support including at least one module receiving portion sized and configured to receive the at least one simulated tissue module;

wherein the simulated tissue module is insertable into and removable from the at least one module receiving portion and interchangeable with another simulated tissue module.

12. The simulated tissue structure of claim 11 wherein the module receiving portion defines a cavity having an opening in the first surface and extending into the module support.

13. The simulated tissue structure of claim 11 wherein the module receiving portion includes a first opening in the first surface and extends into the module support and interconnects with a second opening in the second surface; wherein the at least one simulated tissue module is configured to be disposed between the first and second openings.

14. The simulated tissue structure of claim 11 wherein the simulated tissue portion includes at least one simulated tumor or surgical practice target.

15. The simulated tissue structure of claim 11 wherein the simulated tissue module includes a frame configured to hold the simulated tissue portion; the frame and

module support being configured to connect together in a module receiving portion of the module support.

16. The simulated tissue structure of claim 11 wherein the module support includes a first layer made of elastomeric polymer and a second layer made of low-density elastomeric foam wherein the module receiving portion is formed in at least the second layer.

17. The simulated tissue structure of claim 11 wherein the simulated tissue module includes a simulated tumor made of silicone material located between a first elastomeric layer and a second elastomeric layer; wherein at least one of the first and second elastomeric layers is made of silicone and a mesh reinforcement.

18. The simulated tissue structure of claim 11 wherein the simulated tissue module and the module support are configured such that the simulated tissue module is accessible from the first surface and the second surface of the module support.

19. A method for surgical training, comprising:
providing a simulated tissue structure comprising an artificial tumor located between a base layer and a cover layer;
placing the simulated tissue structure inside a simulated body cavity of a surgical training device such that the simulated tissue structure is at least partially obscured from view by a user;
removing the artificial tumor from the simulated tissue structure;
creating at least one defect substantially in the location of the tumor; the defect comprising two adjacent surfaces defining a gap therebetween; and
closing the gap to bring the two adjacent surfaces together.

20. The method of claim 1 wherein the step of creating at least one defect includes the step of providing a defect layer in the simulated tissue structure.

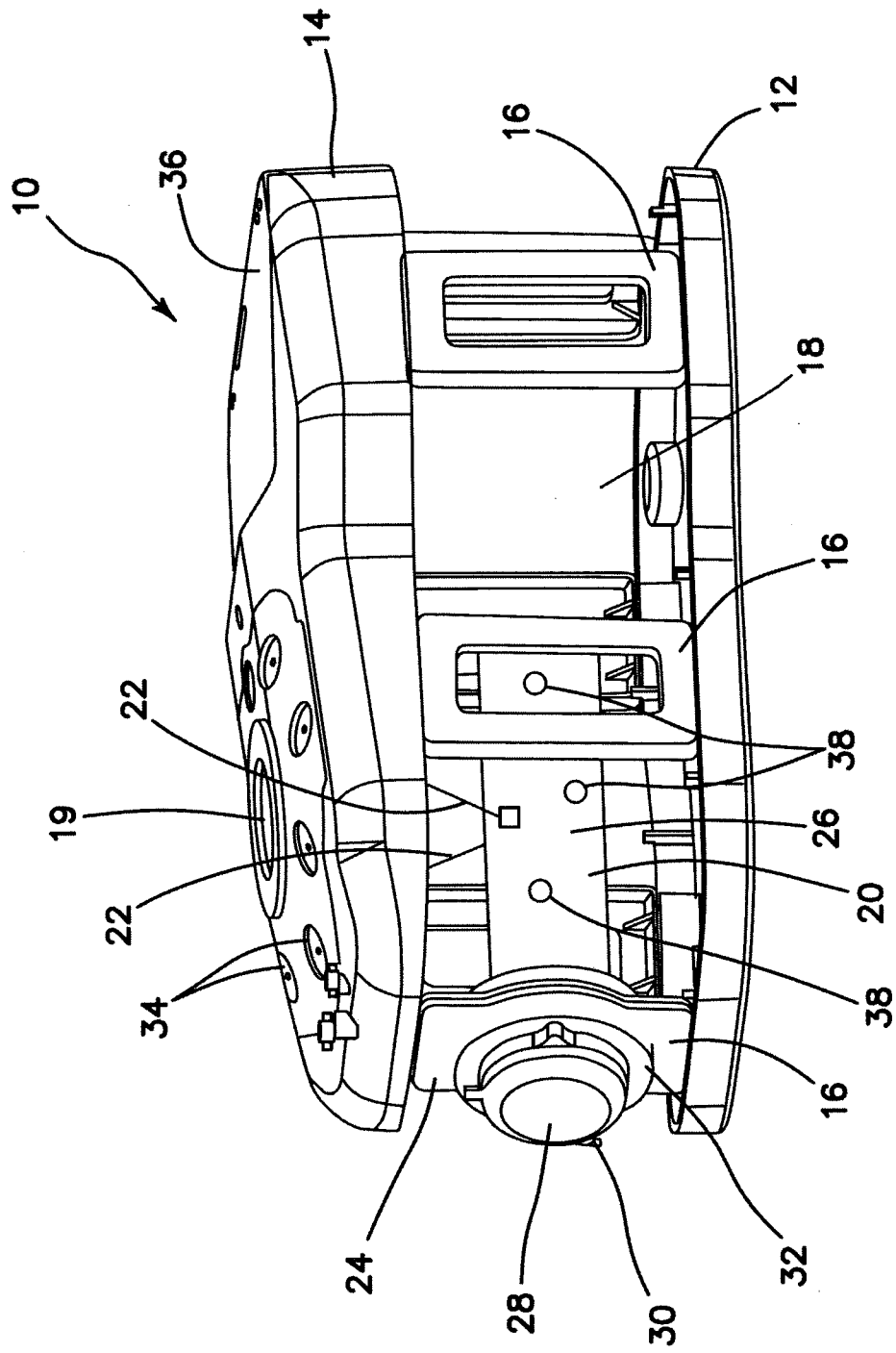

FIG. 1

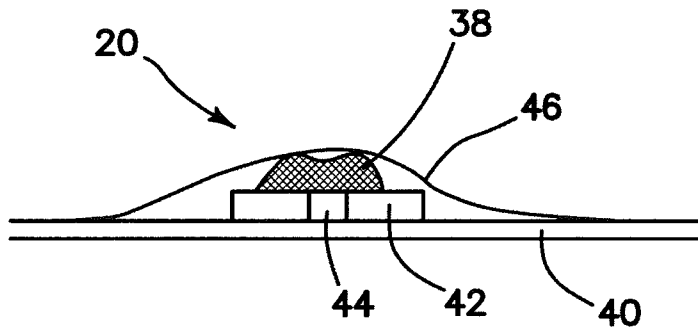

FIG. 2A

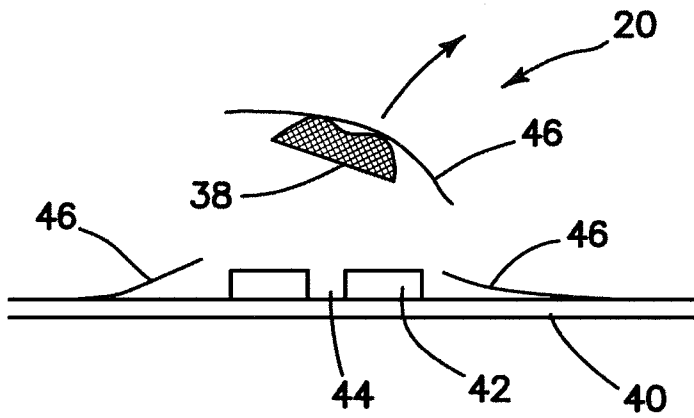

FIG. 2B

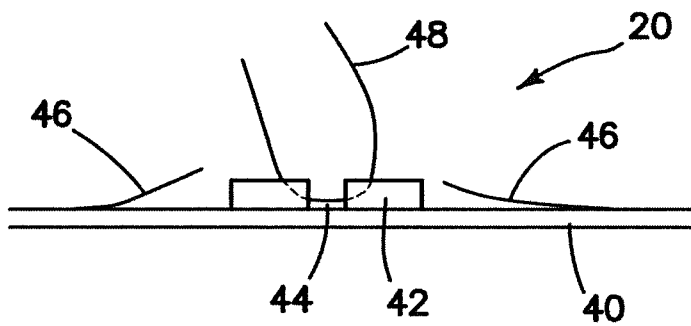

FIG. 2C

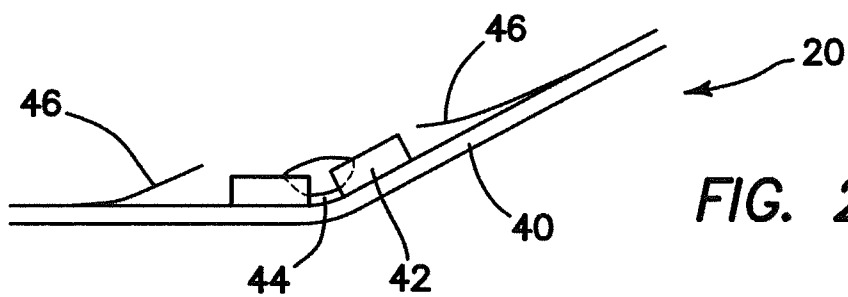

FIG. 2D

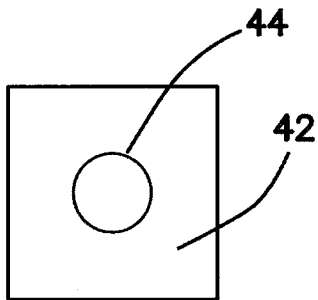

FIG. 3A

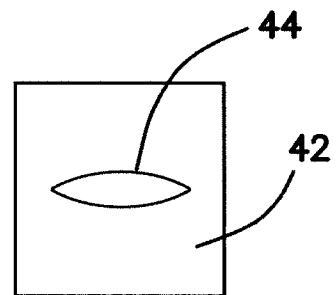

FIG. 3B

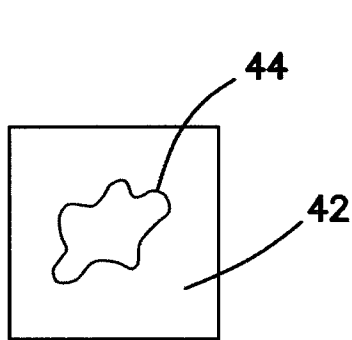

FIG. 3C

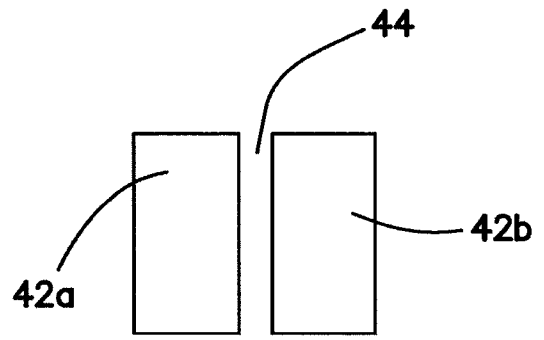

FIG. 3D

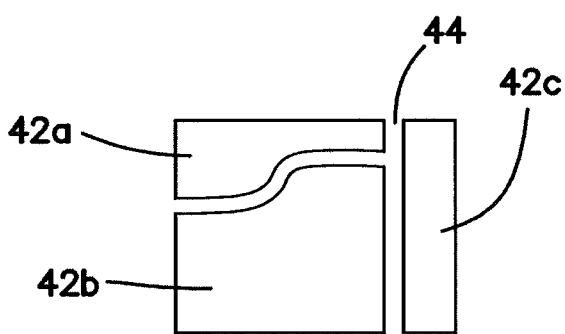

FIG. 3E

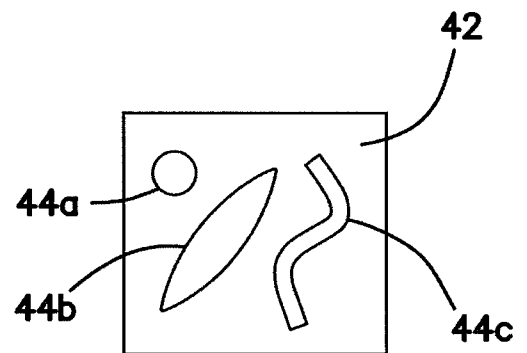

FIG. 3F

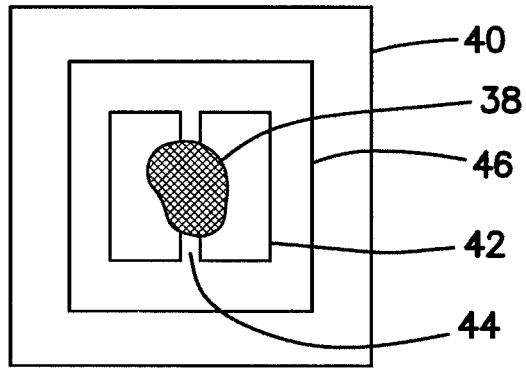

FIG. 4

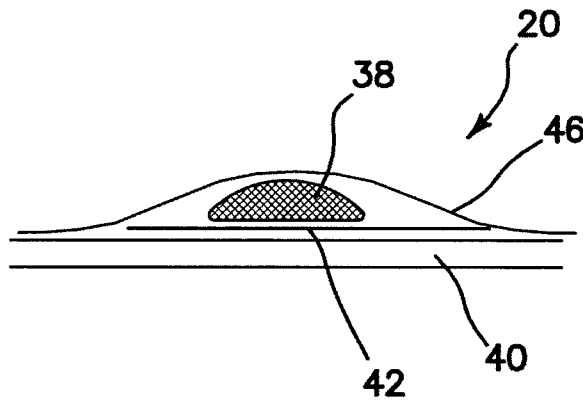

FIG. 5

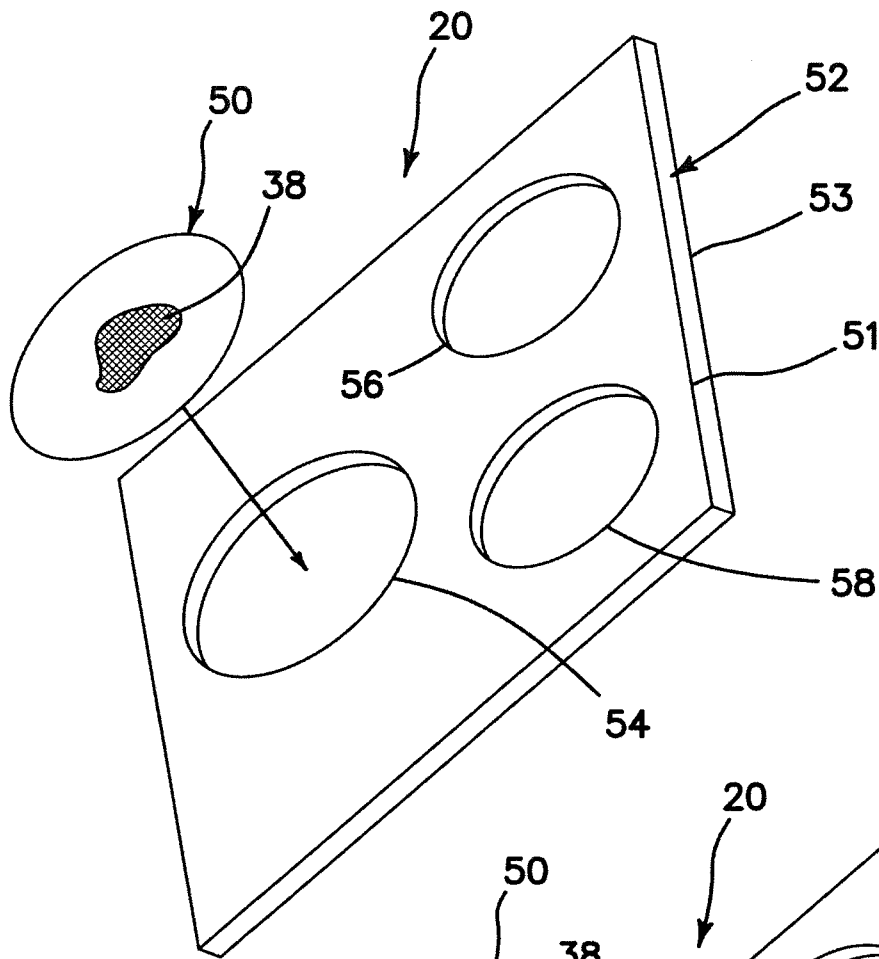

FIG. 6A

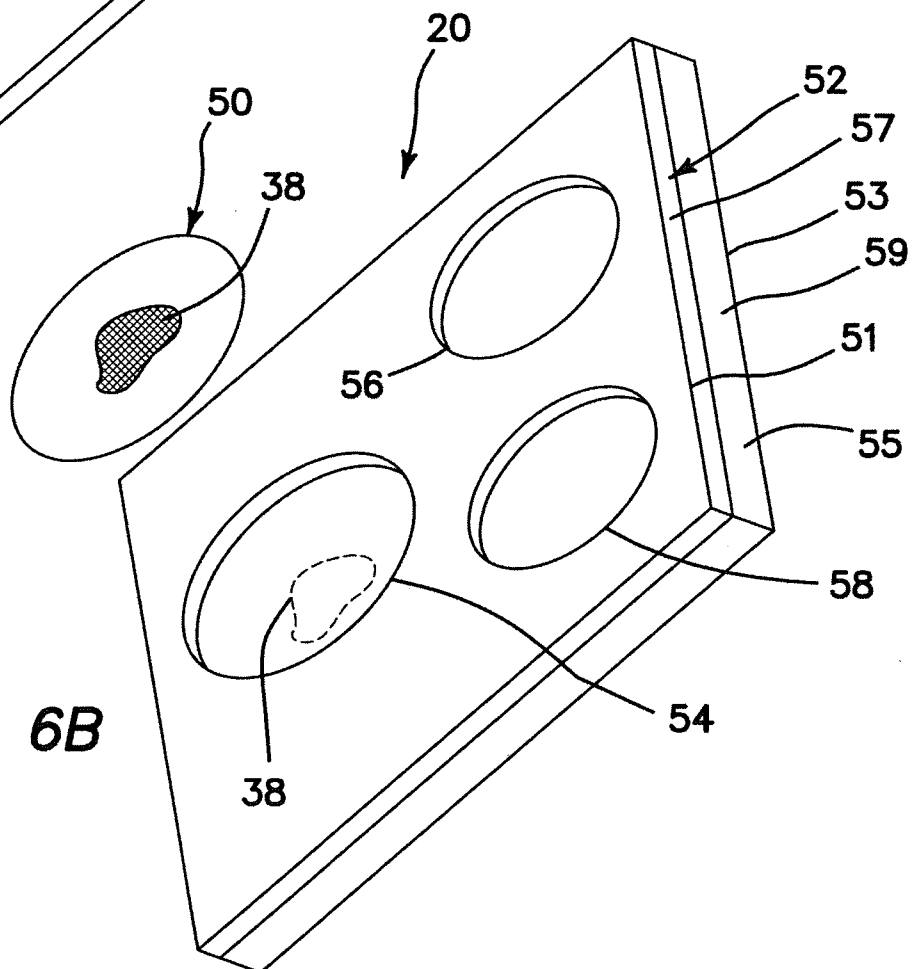

FIG. 6B

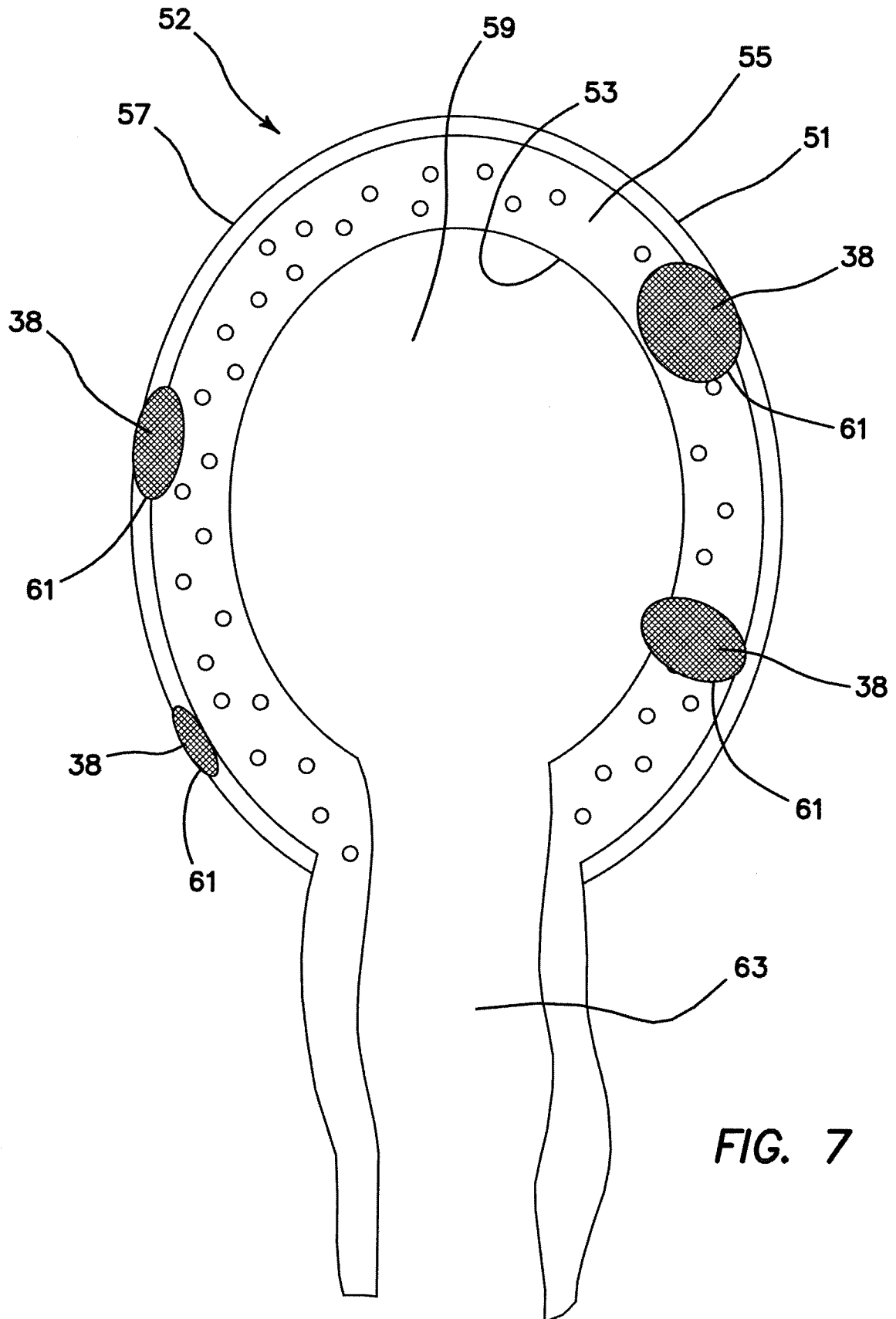

FIG. 7

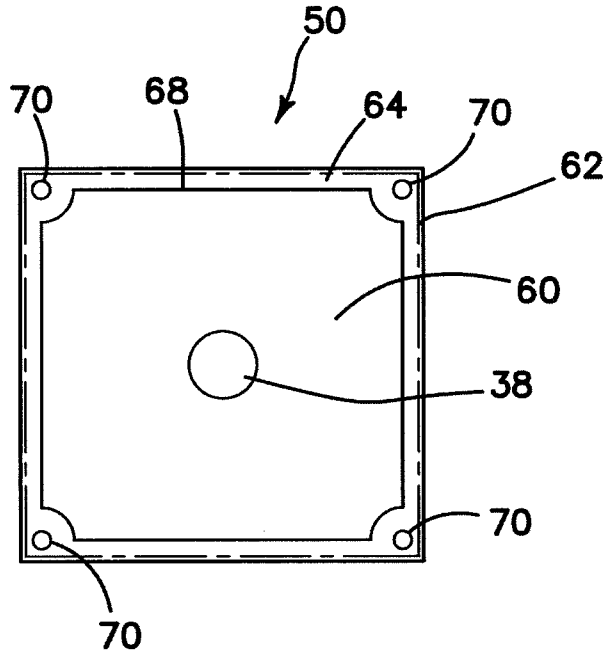

FIG. 8

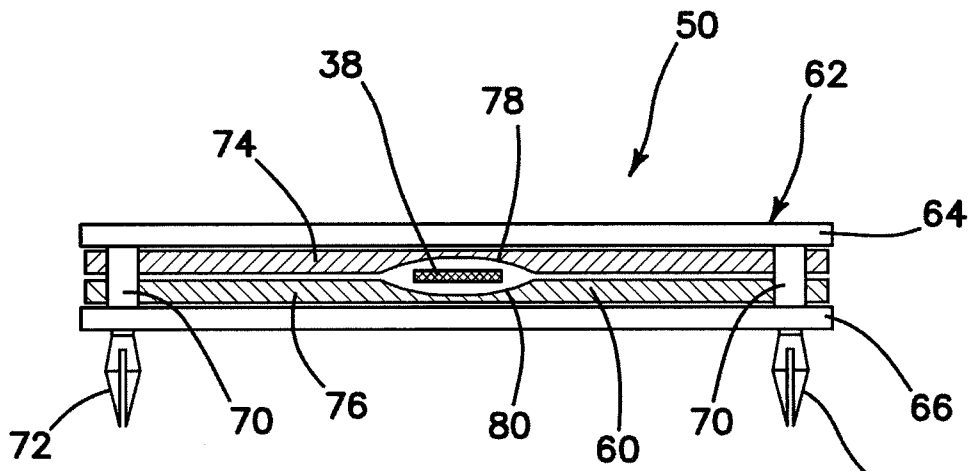

FIG. 9

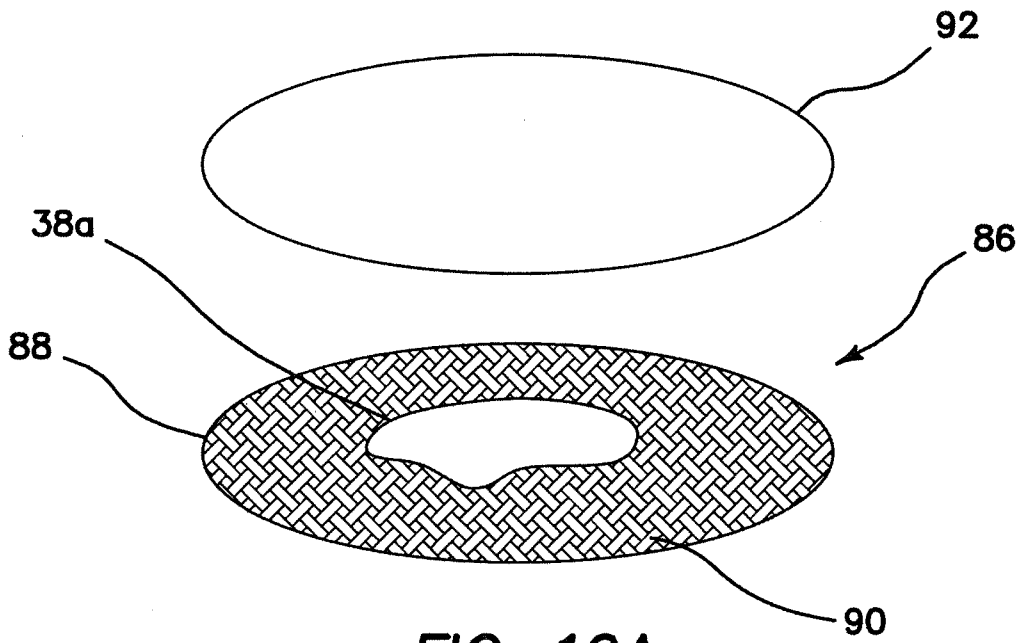

FIG. 10A

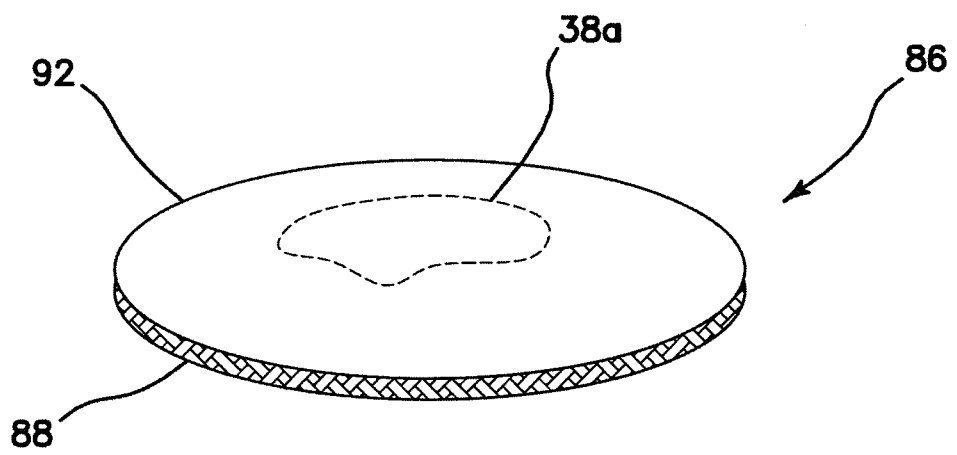
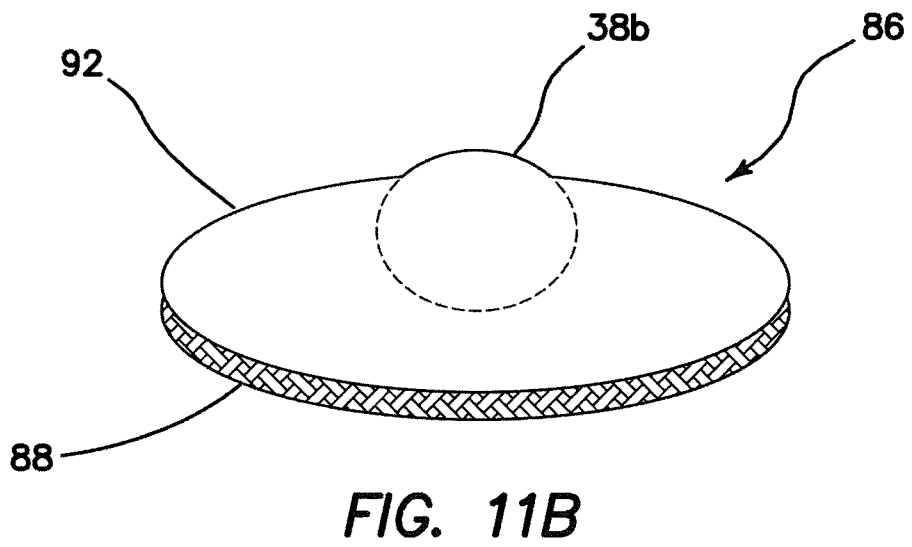
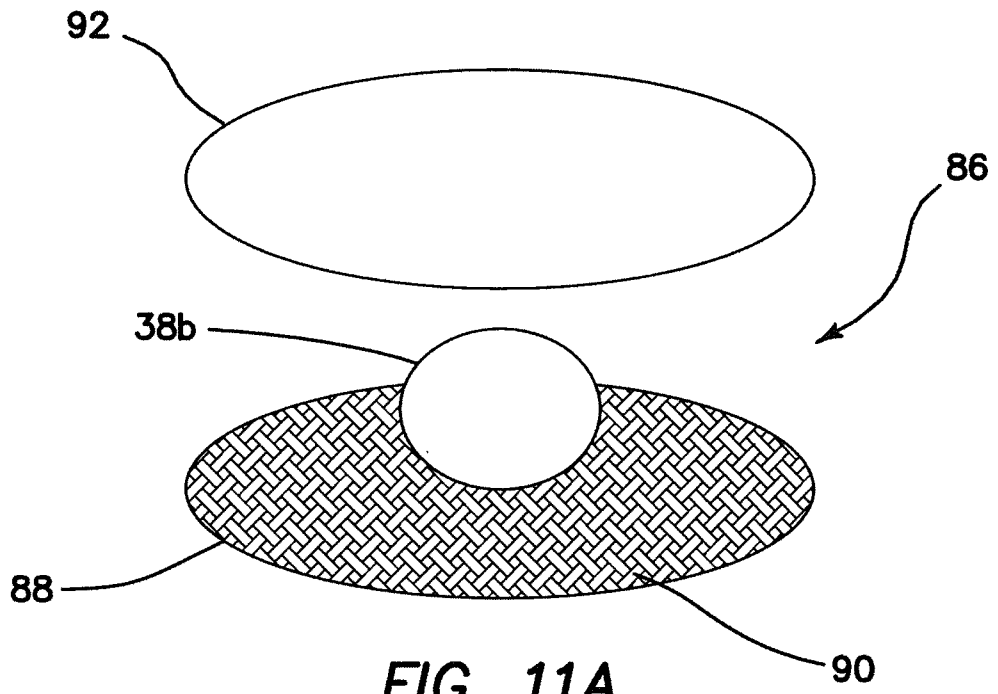

FIG. 10B



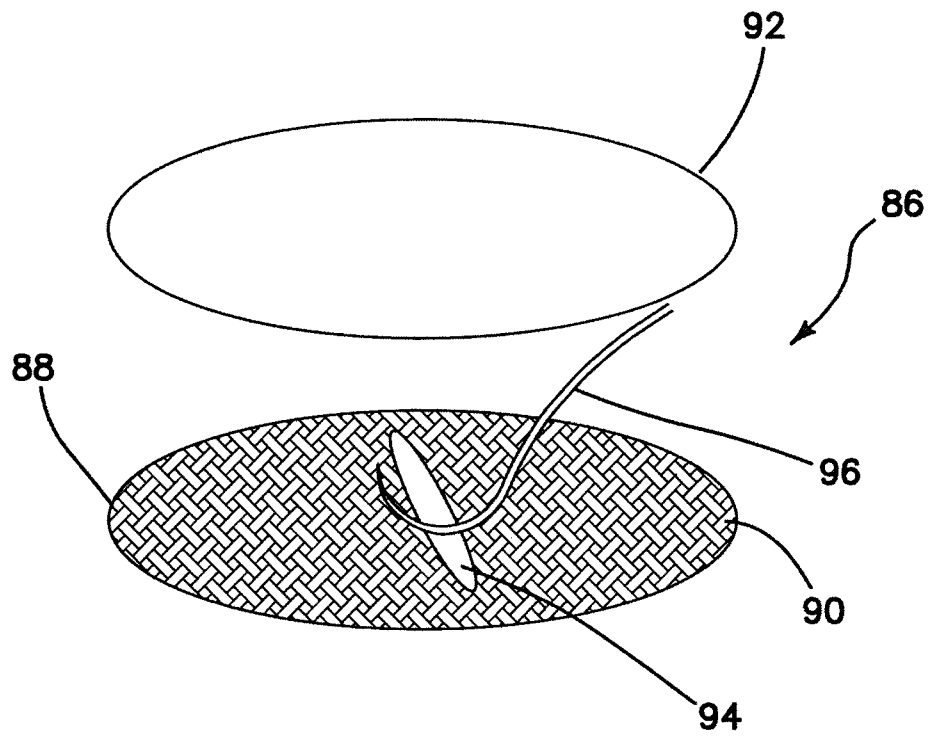

FIG. 12

INTERNATIONAL SEARCH REPORT

International application No
PCT/US2012/060997

A. CLASSIFICATION OF SUBJECT MATTER
INV. G09B23/34
ADD.
According to International Patent Classification (IPC) or to both national classification and IPC

B. FIELDS SEARCHED
Minimum documentation searched (classification system followed by classification symbols)
G09B
Documentation searched other than minimum documentation to the extent that such documents are included in the fields searched

Electronic data base consulted during the international search (name of data base and, where practicable, search terms used)
EPO-Internal

C. DOCUMENTS CONSIDERED TO BE RELEVANT		
Category*	Citation of document, with indication, where appropriate, of the relevant passages	Relevant to claim No.
X	US 2005/026125 A1 (TOLY CHRISTOPHER C [US]) 3 February 2005 (2005-02-03) abstract; claims 1-37; figures 5a,5b paragraph [0009] paragraph [0012] paragraph [0046] paragraph [0058] paragraph [0059]	1-10,19,20
X	US 2010/209899 A1 (PARK ADRIAN E [US] ET AL) 19 August 2010 (2010-08-19) abstract; claims 1,12,13; figure 1 paragraph [0010] paragraph [0005]	1-10,19,20
X	US 5 403 191 A (TUASON LEO B [US]) 4 April 1995 (1995-04-04) abstract; claims 1-4; figures 6,7	11-18

Further documents are listed in the continuation of Box C.

See patent family annex.

* Special categories of cited documents :

- "A" document defining the general state of the art which is not considered to be of particular relevance
- "E" earlier application or patent but published on or after the international filing date
- "L" document which may throw doubts on priority claim(s) or which is cited to establish the publication date of another citation or other special reason (as specified)
- "O" document referring to an oral disclosure, use, exhibition or other means
- "P" document published prior to the international filing date but later than the priority date claimed

- "T" later document published after the international filing date or priority date and not in conflict with the application but cited to understand the principle or theory underlying the invention
- "X" document of particular relevance; the claimed invention cannot be considered novel or cannot be considered to involve an inventive step when the document is taken alone
- "Y" document of particular relevance; the claimed invention cannot be considered to involve an inventive step when the document is combined with one or more other such documents, such combination being obvious to a person skilled in the art
- "&" document member of the same patent family

Date of the actual completion of the international search

26 February 2013

Date of mailing of the international search report

07/03/2013

Name and mailing address of the ISA/
European Patent Office, P.B. 5818 Patentlaan 2
NL - 2280 HV Rijswijk
Tel. (+31-70) 340-2040,
Fax: (+31-70) 340-3016

Authorized officer
Mennerun, Stevee

INTERNATIONAL SEARCH REPORT

Information on patent family members

International application No

PCT/US2012/060997

Patent document cited in search report	Publication date	Patent family member(s)	Publication date
US 2005026125	A1	03-02-2005	NONE
US 2010209899	A1	19-08-2010	NONE
US 5403191	A	04-04-1995	NONE