

Sept. 3, 1935.

S. QUISLING

2,013,289

FUSE PLUG

Filed April 16, 1934

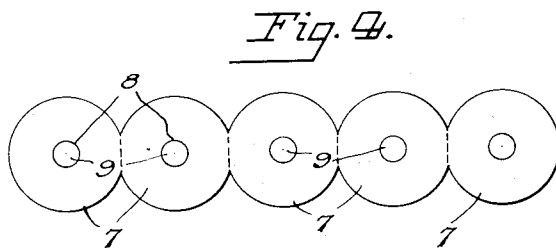
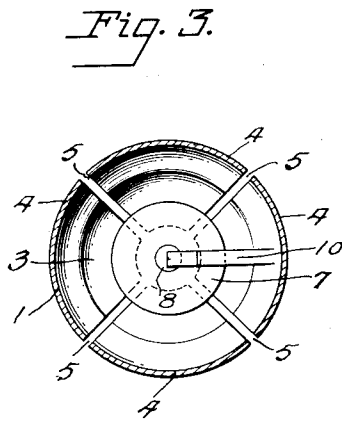
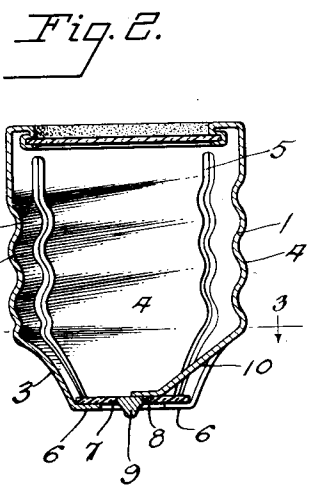
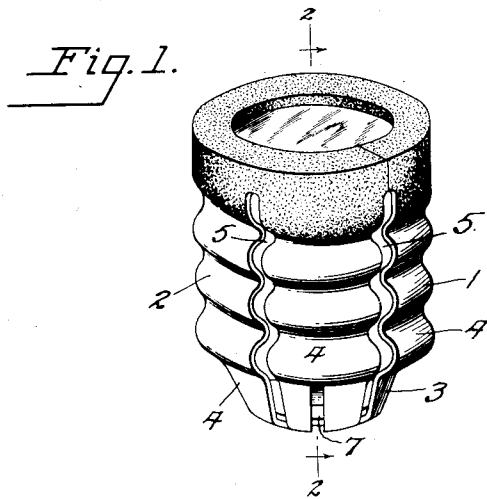

Inventor

Soren Quisling

UNITED STATES PATENT OFFICE

2,013,289

FUSE PLUG

Sverre Quisling, Madison, Wis.

Application April 16, 1934, Serial No. 720,691

6 Claims. (Cl. 200—130)

This invention relates to fuse plugs for electrical circuits.

The object of the present invention is to provide a fuse plug having a renewable fusible element.

Another object of the invention to provide a fuse plug in which the fusible element may be removed and another substituted to carry a heavier or lighter load as desired.

The invention also contemplates the provision of a fuse plug in which a change of color of the fusible element will indicate the condition of the fuse.

A further object of the invention is to provide such a fuse plug which may be manufactured at an extremely low cost.

With these and other objects in view the invention resides in the combination and arrangement of parts herein shown and described. It is of course understood that changes may be made from the precise structure shown without departing from the scope of what is claimed.

In the drawing:

Fig. 1 is a perspective view of a fuse plug constructed in accordance with the present invention;

Fig. 2 is a vertical section on the line 2—2 of Fig. 1;

Fig. 3 is a horizontal section on the line 3—3 of Fig. 2; and

Fig. 4 is an elevational view of a strip of the renewable fusible elements.

As is shown on the drawing, the fuse plug 1 is constructed from a piece of sheet metal, such as copper or the like, stamped out and rolled into form. It is provided with the usual threads 2 for engagement with a socket, tapered lower portion 3, and the upper portion is coated with a non-conducting material such as lacquer to prevent transmitting shock. Throughout the greater portion of its length, the fuse plug body is divided into a plurality of sections 4 by means of the cut away portion 5. The lower end of each of the sections 4 is turned under as at 6 to provide a seat for the fusible element 7. This element 7 is composed of any insulating material and is substantially circular in shape with a hole 8 formed in the center of the disk. Into this hole 8 fusible material 9 may be placed in semi liquid state capable of conducting electric current. If this fusible material is made of a mixture containing metallic magnesium and sulphur, it will appear light colored until blown when it will turn dark brown due to formation of magnesium sulphide. If the mixture contains metallic mag-

nesium and a sulphide of certain earthy metals such as those of barium, zinc, calcium and strontium, together with a radio-active salt such as that of mesothorium or uranium to make them glow, it will appear luminescent as well as light colored until blown when it will become dark. As is shown in Fig. 2 the mixture 9 will extend down below the disk and form the center contact for the fuse. The size of the opening 8 will determine smallest cross-section of conducting fusible element and thus directly control the point at which the mixture will fuse. A large opening will carry a much heavier load than a small opening.

Stamped out from one of the sections 4 is a spring tongue 10 which rests upon the center of the disk 7 and holds it firmly on its seat and at the same time acts as a conductor for the electrical current from the fusible disk to the fuse plug shell.

When the mixture 9 has fused, or if a fuse capable of carrying a different load is desired, the section 4 may be sprung apart releasing the disk 7 and a new disk may be inserted.

Due to the extremely low cost of manufacturing a fuse of this type, a strip of detachable disks 7, such as is shown in Fig. 4, may be supplied with the purchase of each fuse plug. Thus it will be seen that with a single purchase, a fuse having indefinite life may be procured.

Having thus described my invention, what I claim is:

1. A fuse plug comprising a shell divided into a plurality of spring sections throughout the greater portion of its length, a removable fusible element having an opening therein, and fusible material completely filling said opening.

2. In a fuse plug, a shell made from a single stamping divided into a plurality of spring sections throughout the greater portion of its length, a removable disk with fusible material capable of colorimetric changes passing through a hole in its center, and a cut out tongue formed from said shell contacting the upper surface of center of said disk.

3. A fuse plug comprising a shell divided into a plurality of spring sections thruout a portion of its length, a disk of insulating material containing a fusible conducting element to be placed in said shell, and a spring member extending from said shell member to the inside end of the fusible material in said disk to conduct current for the purpose specified.

4. A fuse plug comprising a shell divided into a plurality of spring sections thruout a greater

portion of its length and placed therein, a removable disk of insulating material containing a fusible element capable of colorimetric change when fused, a tongue extending from the shell to the inside end of the fusible element of the disk for conducting current for purpose specified.

5
10 5. A fuse plug comprising a shell portion with means for holding an interchangeable disk, a disk made of insulating material carrying a fusible element passing therethrough from top to bottom, and a tongue extending from the shell por-

tion to the upper inner end of said fusible element in said disk to conduct the current to be regulated therefrom.

6. In a device of the character described, a disk of insulating material containing fusible material extending through a hole from top to bottom, a shell for holding said disk and to serve as a screw plug, and a tongue extending from said shell to conduct electricity from the upper inner end of the fusible material in the said disk.

10
SVERRE QUISLING.