



Europäisches Patentamt  
European Patent Office  
Office européen des brevets



(11) **EP 0 816 789 A2**

(12) **EUROPEAN PATENT APPLICATION**

(43) Date of publication:  
07.01.1998 Bulletin 1998/02

(51) Int. Cl.<sup>6</sup>: **F28F 9/26**, F28D 1/053

(21) Application number: **97201974.9**

(22) Date of filing: **01.07.1997**

(84) Designated Contracting States:  
**AT BE CH DE DK ES FI FR GB GR IE IT LI LU MC  
NL PT SE**

(72) Inventor: **Nysten, Ivo**  
**3500 Hasselt (BE)**

(30) Priority: **02.07.1996 BE 9600601**

(74) Representative:  
**Debrabandere, René**  
**Bureau De Rycker nv**  
**Arenbergstraat 13**  
**2000 Antwerpen (BE)**

(71) Applicant:  
**Jaga, naamloze vennootschap**  
**3590 Diepenbeek (BE)**

(54) **Radiator for central heating and method for assembling such a radiator**

(57) Radiator for central heating, characterized in that it mainly consists of a heating body (2) formed of a number of pipes (3) situated next to one another on the one hand, and of collector canalizations (4-5) which connect the above-mentioned pipes (3) on the other hand and which consist of individual collector connections (6-7) which are provided on the back side (8) of the heating body (2) between the respective pipes (3).

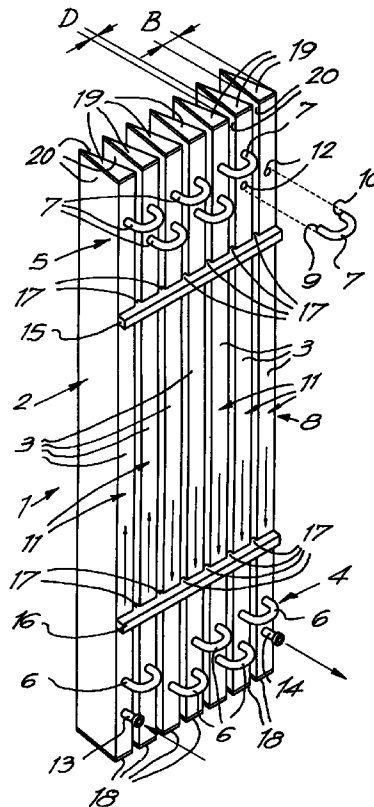

*Fig. 1*

EP 0 816 789 A2

## Description

The present invention concerns a radiator, in particular a radiator for a central heating, as well as a method for assembling such a radiator.

It is known that a radiator for central heating can be made of a number of elements forming a heating body, whereby these elements are connected to a common top collector and a common bottom collector for the supply and discharge of the water respectively. These radiators are disadvantageous in that they can mainly be carried out in a merely flat design. Moreover, the components are usually difficult to assemble.

The invention aims a radiator which does not show the above-mentioned disadvantages. In particular, it aims a radiator which can be easily carried out in all sorts of shapes, either flat or bent, while the canalization of the collector can be easily carried out.

To this aim, the invention concerns a radiator, characterized in that it mainly consists of a heating body formed of a number of pipes situated next to one another on the one hand, and of collector canalizations which connect the above-mentioned pipes on the other hand and which consist of individual collector connections which are provided on the back side of the heating body between the respective pipes.

By making use of individual collector connections which are provided on the back side of the heating body, a whole range of possibilities is created to manufacture radiators in different shapes without the necessary collector canalization causing any problems.

The invention also aims a method to assemble the above-mentioned radiator which allows for a smooth, systematic installation.

To this aim, the method consists in fixing pipes parallel in relation to one another to one or several supports; in sealing these pipes at their crosscut end before or after they have been fixed to the above-mentioned supports and in providing openings on the back sides of the pipes; in connecting the different pipes individually by means of collector connections in the shape of little bent pipes which are fixed in the above-mentioned openings; and in providing connecting pieces to the radiator for the supply and discharge of the water.

In order to better explain the characteristics of the invention, the following preferred embodiments are described as an example only without being limitative in any way, with reference to the accompanying drawings, in which:

figure 1 shows a radiator according to the invention as seen from the back;

figure 2 shows a variant of such a radiator;

figures 3 and 4 show how the radiator of figure 2 is systematically installed;

figure 5 shows another embodiment of a radiator according to the invention;

figures 6 and 7 show how the radiator of figure 5 is

systematically installed;

figures 8 to 15 systematically represent, according to a crosscut view, different embodiments of radiators according to the invention;

figure 16 shows a section of a pipe from a radiator according to the invention.

As is represented in figure 1, a radiator 1 according to the invention mainly consists of a heating body 2 formed of a number of pipes 3 mounted next to one another on the one hand, and of collector canalizations 4-5 which connect the above-mentioned pipes 3 on the other hand and which consist of separate and/or individual collector connections 6-7 between the respective pipes 3 which are provided on the back side 8 of the heating body 2.

The collector connections 6-7 preferably consist of little pipes, which offers the advantage that no particular collector designs have to be developed.

In particular, the collector connections 6-7 are preferably carried out in the shape of bends whose ends 9-10 are directed to the back sides 11 of the pipes 3 concerned. The bends can hereby be secured with the ends 9-10 to the back sides 11 by means of welding, soldering or such. The necessary corresponding openings 12 are provided in the pipes 3 which may consist of bore holes.

Further, the radiator 1 is also provided with connecting pieces 13 and 14 which form for example an inlet and an outlet, or which are designed to be connected to other radiators.

The bends preferably make a connection between each time two pipes 3 situated next to one another, so that the whole can be systematically connected. The pipes 3 are, at least in the case of a vertical erection, consecutively connected both on the top side and on the bottom side, possibly to the exception of one, two or several pipes situated on the inlet, which are not connected any further near said inlet. The latter is represented in figure 1, whereby the first pipe 3 is connected at the bottom, as of the connecting piece 13, to the second pipe 3, but whereby this second pipe 3 is not connected to the third pipe 3 at the bottom. In this manner is obtained that the water which is supplied via the connecting piece 13 must first rise via two pipes and can subsequently flow down again via the other pipes.

The different openings 12 of one and the same pipe are preferably situated on top of one another, such that these openings 12, as well as the bends connecting onto them, have a maximum diameter. The successive collector connections 6, as well as the successive collector connections 7 are preferably also erected perpendicularly.

A major advantage of the use of such individual collector connections 6-7 consists in that the flow pattern can be easily altered as a function of the application by providing collector connections 6-7 wherever required, without having to mount another collector for every

application or for radiators with more or less pipes 3.

According to a variant which is not represented, the connecting piece 13 can also be provided on the top side, whereas the connecting piece 14 is situated at the bottom, or vice versa.

As is represented in figure 1, the pipes 3 are preferably erected vertically and parallel in relation to one another.

The pipes 3 are fixed to one another by means of supports 15-16 upon which they are provided. These supports 15-16 are situated on the back side 8 and preferably have positioning means and/or spacer sleeves 17 which assure the parallel mounting of the pipes 3. The pipes 3 can be welded onto the supports 15-16.

According to the preferred embodiment, the sections of the pipes 3 have converging sides, whereby these pipes converge to the front side.

More in particular, the pipes 3, as represented, have triangular sections and they are directed backward with one side, in particular the above-mentioned back side 11. The crosscut ends of the pipes 3 are sealed, for example by means of plates 18-19 welded onto them.

In particular, the pipes 3 have isosceles triangular sections, whereby the base of the triangular form is directed backward. The shortest distance D between the pipes 3 is preferably smaller than half the dimension B of the above-mentioned base.

The above-mentioned converging shape of the pipes 3 offers several advantages. As the pipes converge, the radiator can be easily carried out in different shapes, both flat as represented in figure 1, and bent as will be further described, but whereby a similar aspect is always obtained.

The converging shape also offers the advantage that an optimum heat emission is obtained. As the side walls 20 of two pipes 3 situated next to one another converge, and the space in between thus widens towards the outside, a smooth air circulation is made possible between the pipes, even when the above-mentioned distance D is very short.

The converging shape of the pipes 3 also offers the advantage that the distance D can be kept very short, without this having any effect on the heat emission, so that the components which are situated on the back side of the radiator, such as the collector connections 6-7, the connecting pieces 13-14 and the supports 15-16 are maximally hidden from view.

The invention is particularly suitable to make radiators with a bent shape, in other words radiators whose front side has a bent curve.

A radiator with a bent heating body 2 is represented as an example in figure 2, whereby the pipes 3 are erected next to one another to this aim according to a semi-cylinder.

The assembly of the whole is represented in figures 3 and 4.

The pipes 3 are hereby cut at the required length and sealed at their crosscut ends by means of the

above-mentioned plates 18-19.

After the pipes 3 have been provided with openings 12, they are fixed to the supports 15-16. These supports 15-16 in this case consist of clips, formed of a semi-cylindrical part 21 and a straight part 22 which connects the ends of the semi-cylindrical part to one another.

In a following stage, which is represented in figure 4, the collector connections 6-7 and the connecting pieces 13-14 are soldered down on the spots concerned, naturally on the back side of the radiator 1, which in this case could also be called the inner side.

De-aerators 23 can possibly be mounted in the top ends of the pipes 3.

Further, as represented in figure 2, the radiator 1 can also be provided with a cock 24, whose connections can possibly be hidden from view by means of a covering 25, for example a bent plate, or by mounting these components behind the pipes 3.

On the top side can be provided a cover 26, for example made of wire netting.

The whole can be easily hung up on a wall by means of hooks 27 which are fixed to the wall, in which the radiator 1 is hooked up with the clips, in particular with the parts 22 thereof. Of course, this radiator 1 can also be erected and fixed in other ways.

Figure 5 shows a variant in which the pipes 3 are erected according to a cylinder, so that a radiator in the shape of a column is obtained. The inner side of the column should be regarded here as the "back side" of the radiator.

The radiator 1 of figure 5 can be easily made by mounting two semi-cylindrical parts analogous to those of figure 4 against one another, as represented in figure 6, for example by means of bolts 28 with which the parts 22 directed towards one another are screwed to one another.

In the case where the pipes 3 enclose or partly enclose a columnar space, which is either or not cylindrical, a fan will be mounted in this space according to a preferred embodiment which creates a forced air flow over the pipes 3. In the embodiment of figures 5, 6 and 7, use is made of a fan 29 with a built-in motor which is placed on the top support 15-16, whereby a protection is provided over this fan 29, such as a cover 26 made of wire netting or such.

As is represented in figures 5 and 7, the whole can be mounted on a foot 30. Practically, this can be done by providing a number of screw blocks 31 against the back side 8 of a number of pipes 3 which can cooperate with props 32 which are part of the foot 30.

The screw blocks 31 are provided with at least two holes 33 with internal screw thread provided on top of one another, in which bolts 34 can be screwed.

The props 32 are made of U-shaped profiles and thus form a guide for the screw blocks 31. Further, these props 32 are provided at their top ends with a seating 35 in the shape of a recess and a bore hole 36 provided underneath it.

During the mounting, bolts 34 are first screwed in the top holes 33 and the foot 30 is pushed in the heating body 2 until the bolts 34 take place in the seatings 35. Then, the bottom bolts 34 must be screwed through the bore holes 36 in the lower holes 33. Finally, all bolts 34 are tightened.

Analogous to the embodiment of figure 2, the whole can be equipped with a cock 24, whereby the necessary connections can be hidden from view by means of a covering 25.

The two semi-cylindrical parts of the radiator 1 can be connected in shunt as well as in series. In the latter case, they are connected by means of a connecting piece 37 as represented in figure 6 which connects the outlet of the first radiator to the inlet of the second one.

It should be noted that the use of triangular pipes, combined with a spherical outside surface of the radiator, results in a very good heat emission thanks to a good convection with the air easily rising between the pipes on the one hand, and also because radiant heat is generated in many directions and is at the same time spread quite uniformly on the other hand.

The present invention is by no means restricted to the embodiments described as an example and represented in the accompanying drawings; on the contrary, such a radiator can be made in various forms and dimensions while still remaining within the scope of the invention.

For example, the radiator 1 can be made in other shapes, either or not bent. Several examples thereof are represented by means of a schematic view of a crosscut face of such a radiator 1 in figures 8 to 15, whereby no collector canalizations are represented for clarity's sake.

It should be noted that the radiator 1 according to the invention can also be mounted with the pipes 3 horizontally, whereby the collector canalizations 4-5 are then situated on the left and right hand side.

Finally, a variant of a pipe 3 with converging side walls 20 is represented in figure 16, whereby this pipe 3, as opposed to the triangular section, now has a trapezoidal section.

## Claims

1. Radiator for central heating, characterized in that it mainly consists of a heating body (2) formed of a number of pipes (3) situated next to one another on the one hand, and of collector canalizations (4-5) which connect the above-mentioned pipes (3) on the other hand and which consist of individual collector connections (6-7) which are provided on the back side (8) of the heating body (2) between the respective pipes (3).
2. Radiator according to claim 1, characterized in that the collector connections (6-7) consist of little pipes.

3. Radiator according to claim 2, characterized in that the collector connections (6-7) are made in the shape of bends.
4. Radiator according to claim 3, characterized in that the bends each time make a connection between two pipes (3) situated next to one another.
5. Radiator according to claim 4, characterized in that the pipes (3) are consecutively connected on both ends by means of the above-mentioned collector connections (6-7), possibly to the exception of one, two or several pipes (3) situated on the inlet, which is/are not connected to the other pipes (3) near said inlet.
6. Radiator according to any of the preceding claims, characterized in that the collector connections (6-7) are secured on the back sides (11) of the pipes (3) by means of welding, soldering or such.
7. Radiator according to any of the preceding claims, characterized in that the pipes (3) are erected vertically and parallel in relation to one another.
8. Radiator according to any of the preceding claims, characterized in that the section of the pipes (3) has forwardly converging side walls (20), in particular a triangular or trapezoidal section, whereas these pipes (3) are directed with one side (11), forming a base, to the back side (8) of the heating body (2), in particular from the back side (8) thereof.
9. Radiator according to claim 8, characterized in that the pipes (3) have an isosceles triangular section, whereby the base of the triangular form is each time directed backward.
10. Radiator according to claim 8 or 9, characterized in that the shortest distance (D) between the pipes (3) is smaller than half the dimension (B) of the above-mentioned base.
11. Radiator according to any of the preceding claims, characterized in that the pipes (3) are connected to one another by means of supports (15-16) which extend along the back sides (11) of the pipes (3).
12. Radiator according to any of the preceding claims, characterized in that the heating body (2) is bent, in other words that the pipes (3) are erected next to one another according to a bent surface.
13. Radiator according to claims 11 and 12, characterized in that the supports (15-16) consist of clips in the shape of a semi-circle or a virtually semi-circle.
14. Radiator according to claim 12 or 13, characterized

in that the heating body (2) is bent, whereby the pipes (3) are erected next to one another according to either of the following possibilities:

- according to a semi-cylinder; 5
- according to a cylinder casing in the shape of a column.

15. Radiator according to claim 14, characterized in that the pipes (3) are erected according to a cylinder casing and in that the radiator (1) is composed of two semi-cylindrical parts which are fixed to one another. 10

16. Radiator according to any of the preceding claims, characterized in that the pipes (3) enclose a columnar space and in that a fan (29) is placed in this space. 15

17. Method for assembling a radiator as described in claim 1, characterized in that it consists in fixing pipes (3) parallel in relation to one another to one or several supports (15-16); in sealing these pipes (3) at their crosscut end before or after they have been fixed to the above-mentioned supports (15-16) and in providing openings (12) on the back sides (11) of the pipes (3); in connecting the different pipes (3) individually by means of collector connections (6-7) in the shape of little bent pipes which are fixed in the above-mentioned openings; and in providing connecting pieces (13-14) to the radiator (1) for the supply and discharge of the water. 20 25 30

35

40

45

50

55

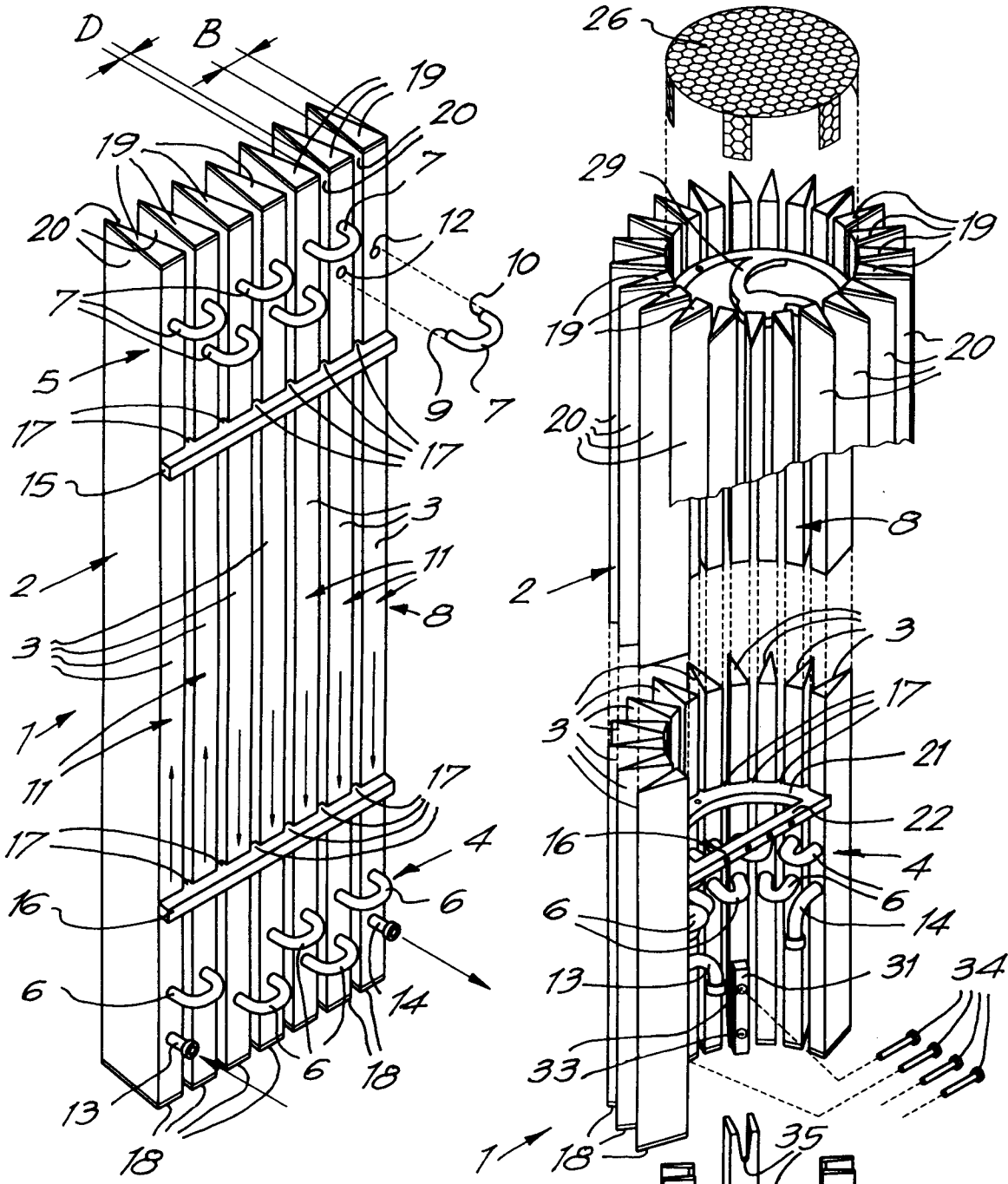

*Fig. 1*

*Fig. 7*

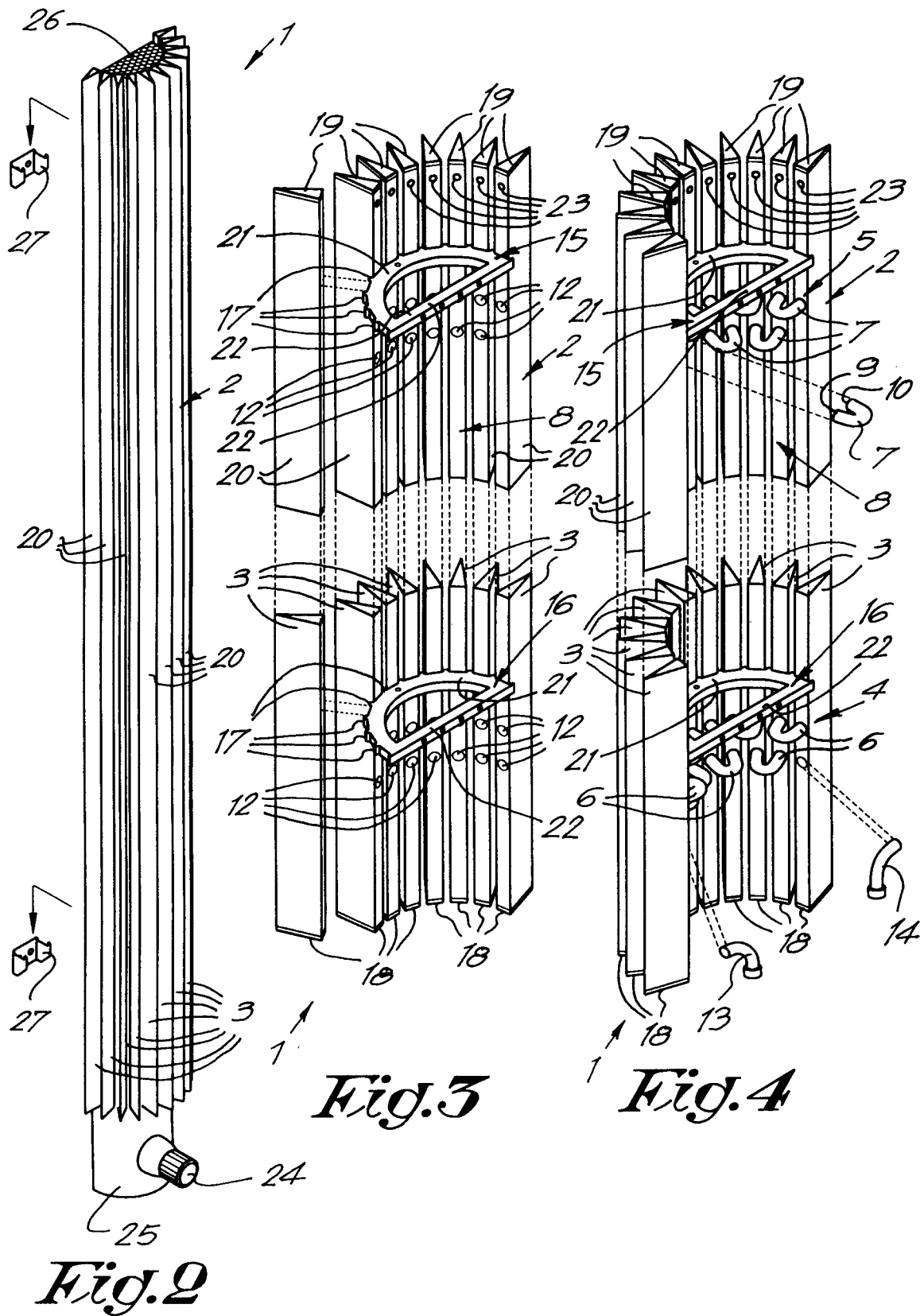

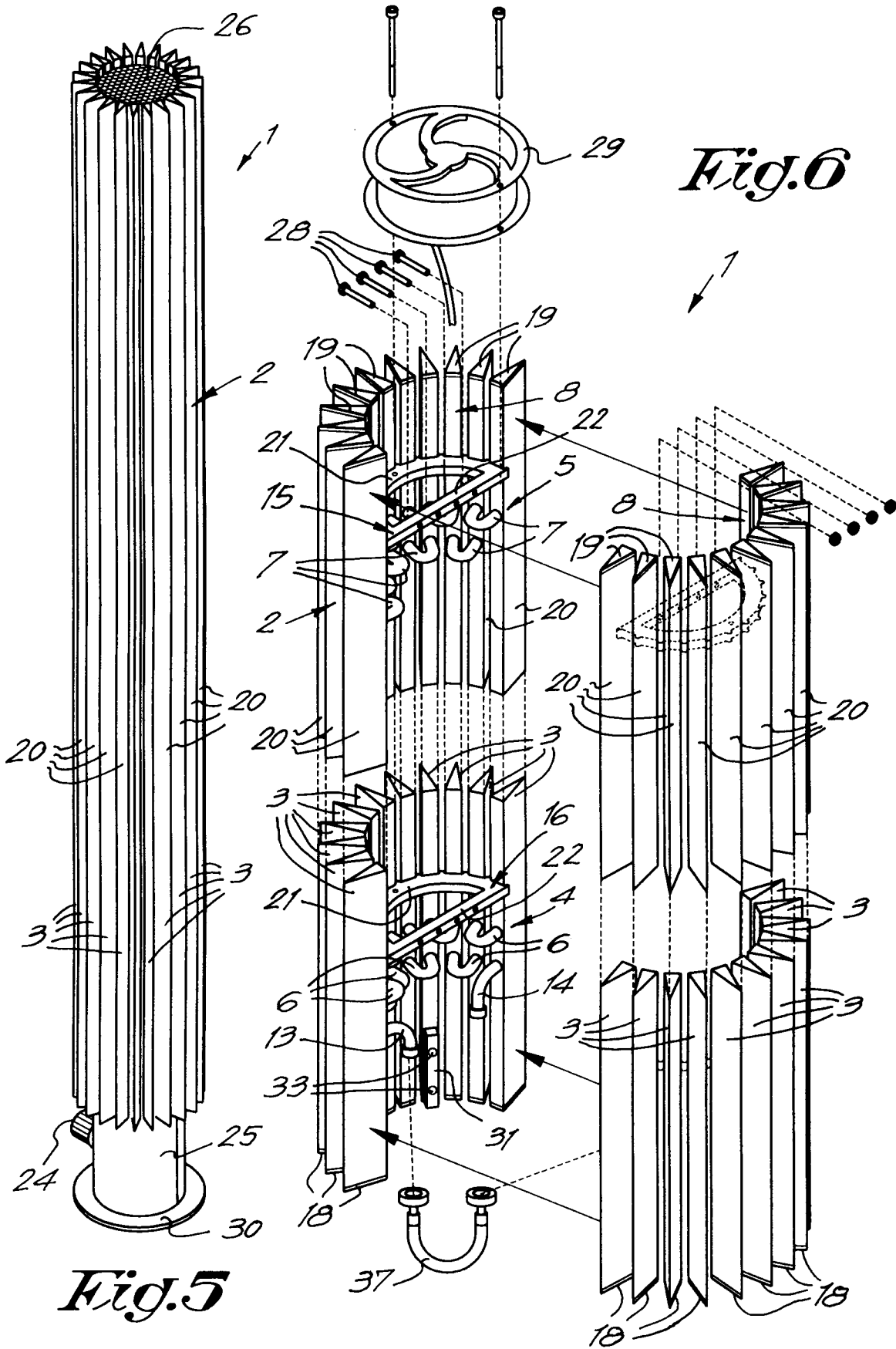

*Fig.5*

*Fig.6*

