

B. OSGOOD.

PUMP.

APPLICATION FILED FEB. 13, 1911.

998,547.

Patented July 18, 1911.

2 SHEETS—SHEET 1.

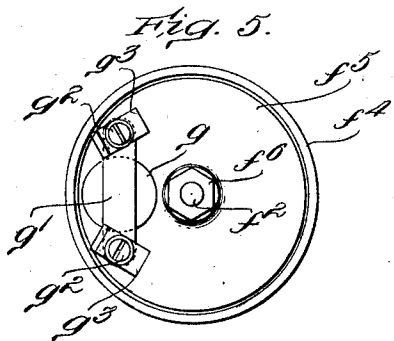
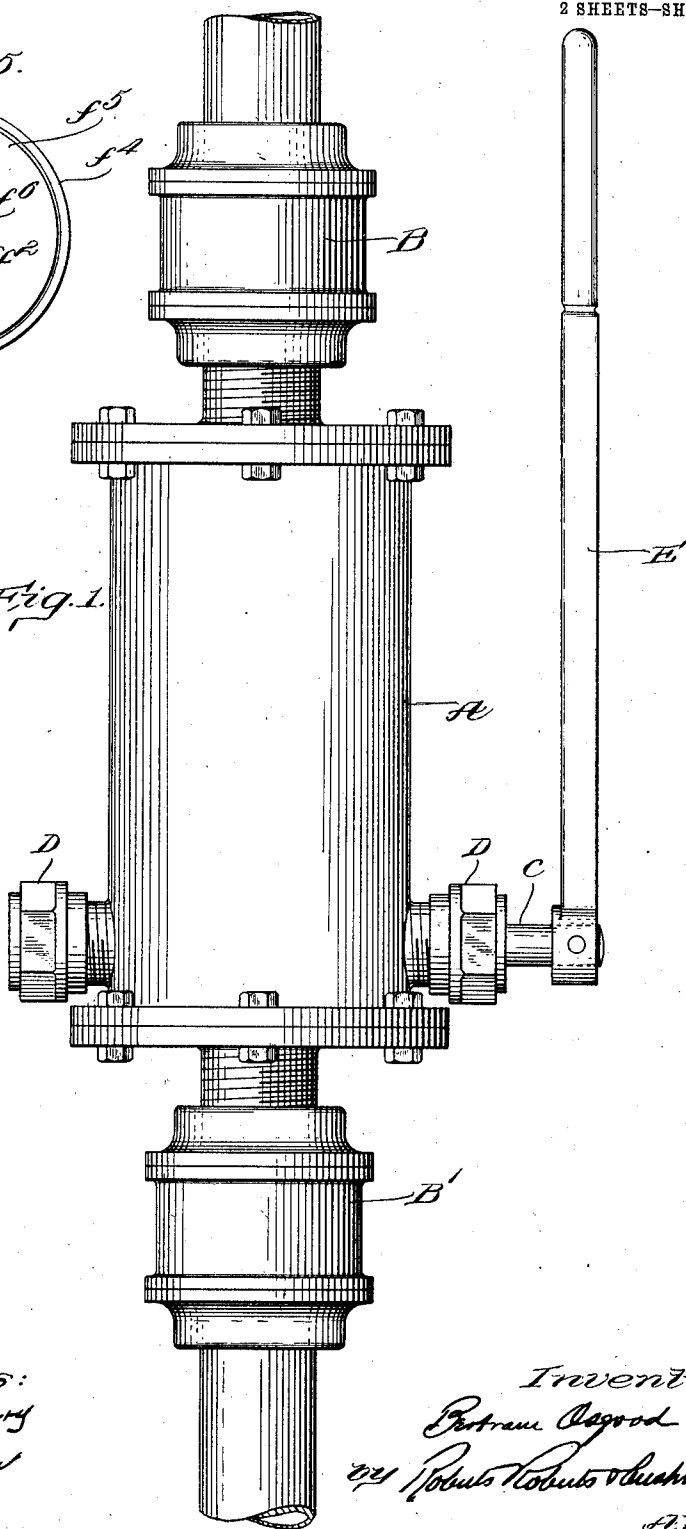

Fig. 1.



Witnesses:
 Charles S. Woodberry
 Josephine H. Ryan

Inventor:
 Burt Osgood
 by Robert Roberts & Cheatham
 Attys.

UNITED STATES PATENT OFFICE.

BERTRAM OSGOOD, OF SALEM, MASSACHUSETTS.

PUMP.

998,547.

Specification of Letters Patent.

Patented July 18, 1911.

Application filed February 13, 1911. Serial No. 608,181.

To all whom it may concern:

Be it known that I, BERTRAM OSGOOD, a citizen of the United States, and resident of Salem, in the county of Essex and State of Massachusetts, have invented new and useful Improvements in Pumps, of which the following is a specification.

My invention relates to pumps, and its object is to provide an improved pump which while adapted for use under all the usual conditions of service, is peculiarly adapted for high pressure work.

My invention is characterized by a piston mounted to rock and to reciprocate simultaneously within the pump cylinder and in the best form of the invention at present known to me, this movement or stroke of the piston is obtained by a suitable actuator and piston connected by a toggle joint as shown in the drawings hereto annexed.

Referring to the drawings,—Figure 1 is a side elevation of my improved valve; Fig. 2 is a sectional view showing the piston in mid-position; Figs. 3 and 4 are similar views showing the piston at the limits of its movement or stroke; and Fig. 5 is a plan view of the top of the piston.

A is the pump cylinder of the usual construction provided with the usual intake and outlet pipes and check valves B and B' at the top and bottom. A shaft C having suitable bushings D is mounted to oscillate or rock within said cylinder, and is provided at its end with an operating handle or lever E. The piston consists of a stud F having a forked end f , a disk-shaped head f' , and a threaded stud f^2 centrally located on said head and preferably integral therewith. An annular cup f^3 of leather or similar material having a flange extending part way around its periphery, is fitted over said head f' , the flange extending downward beyond the edge of said head. A second annular cup f^4 of leather or similar material having an upwardly projecting flange extending completely around its periphery, rests upon said first named cup. The flanges of the said cups f^3 , f^4 fit against the side of the cylinder when the piston is in normal position as shown in Fig. 2. The stud f^2 passes through the center of said cups f^3 and f^4 and through a metal plate f^5 which is held upon the face of said cup f^4 by a nut f^6 upon the threaded stud f^2 , thus firmly binding the said cups to said stud F.

Through that portion of the piston which

is provided with both the upwardly and downwardly extending cup flanges there is cut a port f^7 normally closed by a valve located upon the top of the piston. As shown in the drawings, the valve comprises a metal plate or cover g (Fig. 5) and a metal strap g' secured at each end by screws g^2 . Springs g^3 are provided between the heads of the screws g^2 and the strap g' so that the cover g is yieldingly held in closed position against the top of the piston. Upon the shaft C there is fixed, as by the pin c and set screw c' , an arm H. The upper end of the arm H fits between the forked end f of the stud F and is pivotally secured thereto by the pin h thus forming a toggle joint.

The operation of the pump is as follows: The pump cylinder A being filled with water and the parts in the position shown in Fig. 2, which I will call the normal position, the handle E is swung to the left as viewed in the drawings. This movement of the handle rocks the shaft C which rocking movement being communicated to the piston through the toggle joint connection, causes the piston to rock so that at the termination of the left hand stroke the parts assume the position shown in Fig. 3. It will be clear, that because of the toggle connection of the piston and shaft C, the movement of the piston from the position shown in Fig. 2 to that shown in Fig. 3, is not a rocking movement simply, but that simultaneously with the rocking there is a downward movement of the entire piston within the cylinder. As the piston moves from the position shown in Fig. 2 to that shown in Fig. 3 the yieldingly held cover g of the port f^7 is forced open so that the pump sucks water from the lower chamber to the upper chamber until the piston has reached the end of its stroke. The volumes of water in the chambers having thus been changed, the handle E is swung from the position shown in Fig. 3 to that shown in Fig. 4, that is to the right as viewed in the drawings. This movement of the handle again rocks the shaft C but in the opposite direction, which movement being communicated to the piston as above described, simultaneously rocks and raises the piston and, by reason of the straightening out of the toggle joint, brings it back to normal position shown in Fig. 2 with a quick, strong, upward thrust thus ejecting the water from the chamber above the cylinder. The con-

tinued movement of the handle to the right, rocks and lowers the piston from normal position so that at the finish of the pumping stroke the parts are in the position shown in Fig. 4. The handle E is then again swung to the left as viewed in the drawings again rocking and raising the piston to normal position in the manner already described, and then back to the position shown in Fig. 3.

In pumping against low pressure, the water will be ejected from the cylinder not only when the piston moves from the position shown in Fig. 3 to normal position, but also when it moves from the position shown in Fig. 4 to normal position. In pumping against high pressure however the water will be ejected but once in each complete rock or oscillation of the shaft C; that is to say, in high pressure work the piston will not pump upon its movement from the position shown in Fig. 4 to normal position, but only on its movement from the position shown in Fig. 3 to normal position. For high pressure work I have found it desirable in practice to extend the flange of the cup f^3 about half way around the periphery and to locate the port f^1 at about the center of that half of the piston which is provided with the half flange.

The functional significance of the combined or coexistent rocking and reciprocating movements of the piston, stands in a useful relation to the well known peculiarities of operation of the toggle joint, and is as follows: The rocking or oscillating movement causes the displacement of the downwardly moving side of the piston to offset in part the displacement due to the movement of the upwardly oscillating half. If this oscillation were about an axis passing through the geometrical center of the piston and this axis did not move up or down, then the displacement due to oscillation of the piston would be zero, since the displacement of the upwardly moving half would be exactly compensated for by the displacement of the downwardly moving half. But the operation of the toggle causes the oscillation to take place about a shifting axis at one side of the geometrical center of the piston, so that the displacement of the downwardly moving side due to oscillation is less than that due to the upwardly moving side. Thus, when the toggle, as in the position shown in Fig. 4 or Fig. 3, is that of least mechanical advantage in effecting an upward thrust, the virtual piston area is only that due to the differential between the two displacements of oscillation of the respective halves or sides of the piston, and as this virtually effective piston area is small, at the time when the upward reciprocating movement of the piston is large, for a given angular unit of movement of the toggle arm,

the disadvantageous position of the toggle is compensated for and the pump works against high pressure without necessitating the exertion of excessive force upon the operating lever. As the toggle approaches the position shown in Fig. 2, the actual axis of oscillation of the piston moves farther and farther away from the geometrical center of the piston, and the virtual piston area, which is the differential between the above described oscillation displacements of the parts of the piston on either side of the axis of oscillation is increased, the effective application of force by the toggle also increases, and when the piston becomes substantially horizontal, as in Fig. 2, and the final movement is one of substantially unqualified reciprocation, and thus the whole piston area is effective, the toggle also is in its most effective position for power application. Thus, the toggle arrangement is effective to pump against a substantially constant and high pressure by the application of a substantially uniform effort at the end of the operating lever. If a toggle arrangement such as is shown were to be applied to an ordinary piston which reciprocates without oscillation, the effort required to pump against any given pressure when the toggle assumed a position like that in Fig. 3, would be enormously greater than that required when the toggle becomes nearly straight as in Fig. 2.

I claim:

1. In a pump, the combination with a cylinder, of a peripherally packed piston and means simultaneously to rock and to reciprocate the piston in the cylinder.
2. In a pump, the combination with a cylinder of a piston and an actuator therefor connected therewith by a toggle joint, said piston adapted simultaneously to rock and to reciprocate within said cylinder when said actuator is operated.
3. In a pump, the combination with a cylinder of a piston having on one face an annular packing flange extending completely around the periphery thereof, and on its opposite face a packing flange extending part way around the periphery, and means simultaneously to rock and to reciprocate the piston within said cylinder.
4. In a pump, the combination with a cylinder of a piston having on one face an annular packing flange extending completely around the periphery thereof, and on its opposite face a packing flange extending part way around the periphery, an actuator for said piston connected therewith by a toggle joint, said piston adapted simultaneously to rock and to reciprocate within said cylinder when said actuator is operated.
5. In a pump, the combination with a cylinder of a piston having on one face an annular packing flange extending completely

around the periphery thereof, and on its opposite face a packing flange extending part way around the periphery, a port in said piston, a valve normally closing said port, and means simultaneously to rock and to reciprocate the piston within said cylinder.

6. In a pump, the combination with a cylinder of a piston having on one face an annular packing flange extending completely around the periphery thereof, and on its opposite face a packing flange extending part way around the periphery, a port in said piston, a valve normally closing said port, an actuator for said piston connected therewith by a toggle joint, said piston adapted simultaneously to rock and to reciprocate within said cylinder when said actuator is operated.

7. In a pump, the combination with a cylinder of a piston having on one face an annular packing flange extending completely around the periphery thereof, and on its opposite face a packing flange extending part way around the periphery, a port in said piston, a valve normally closing said port, a stud on said piston, a shaft, an arm fast to said shaft and pivotally secured to said stud

to form a toggle joint, said piston adapted simultaneously to rock and to reciprocate within said cylinder when said shaft is oscillated.

8. In a pump, the combination with a cylinder of a piston having on its upper face an annular packing flange extending completely around the periphery thereof and on the lower face a packing flange extending half way around the periphery, a port in said piston located upon the same half thereof as said half flange, a cover normally closing said port, means on the upper face of said piston adapted yieldingly to hold said cover in normal closed position, a forked stud on said piston, a shaft, an arm fast to said shaft and pivotally secured to said forked stud to form a toggle joint, said piston adapted simultaneously to rock and to reciprocate within said cylinder when said shaft is oscillated.

Signed by me at Boston, Massachusetts, this 9th day of February, 1911.

BERTRAM OSGOOD.

Witnesses:

WILLIAM T. WALKE,
CHARLES D. WOODBERRY.

Copies of this patent may be obtained for five cents each, by addressing the "Commissioner of Patents, Washington, D. C."