

Description

[0001] The present invention relates to a roof structure with a fibrous insulating panel assembly, said roof structure including an insulation layer of fibrous insulating material, which is mounted onto a support structure by anchoring means including at least one of longitudinal anchoring profile on the outside of the insulating material layer for retaining the insulation layer and for supporting a top panel structure, which may be secured to said at least one profile, which are secured to the support structure through the insulation layer by connecting elements

[0002] A roof structure of such kind is known from EP-A-0 685 612. According to the double layer roof system described therein, the insulation material is put in place on the support structure of the roof. A U-shaped profile is then machined into the insulation material by a machining tool which is utilised on the roof. The insulation is typically a dual density product comprising a lower layer of mineral fibres with relative low density and an outer top layer with relatively high density. The top layer provides the insulation with a treading resistance as well as a distribution of pressure. The U-profile provides for the transfer of upwardly directed wind forces as well as transfer of shearing forces to the support structure via the anchoring screws. The top panel structure is fixedly secured to the U-profiles at a number of positions whereas the U-profile is fixedly secured to the support structure at other positions.

[0003] In the roof construction according to EP-A-0 685 612, the insulation panels may be separately fixed to the roof furring construction, i.e. the support structure, via the anchoring profiles extending across the insulation panels. The top panel structure may subsequently be mounted onto the anchoring profiles. The profiles stabilises the insulation panels before the top structure is mounted thereon. The profiles may be appropriately anchored to the support structure, such as a trapezium sheet panel to which the profiles are fixed to the high ridges of this supporting trapezium sheet panel. The anchoring profiles are fixed to the support structure at as many points as necessary in order to ensure a firm anchoring enabling the profiles to carry the load of the top structure.

[0004] A drawback of this roof structure is that a machine tool must be utilised on the roof in order to machine a set of grooves for fitting the U-shaped anchoring profile in the top surface of the insulation. This machine must be lifted up on the roof and back down again after use. This is both time consuming and contributes to extra costs for building the under-roof structure. From WO 03/016652 a sub-structure for a roof is known, where a simple metal strip is provided for fixing the insulation to the support structure. However, this fixation lacks any stiffness and does not contribute of absorbing any roof load, such as wind load suction or compression due to the weight of snow on the roof.

[0005] On this background, it is an object for the

present invention to provide a stiff roof structure where the tooling requirement for laying the roof, and in particular fitting the anchoring profiles, is reduced or even eliminated.

[0006] This object is achieved by a roof structure of the initially mentioned kind wherein said at least one anchoring profile comprises at least one profile retention portion having a resting surface, which rests on the outer surface of the insulation panel, and at least one longitudinally oriented inwardly protruding profile portion and that at least the outer portion of the insulation panel is having a low density, so that the inwardly protruding portion locally compress the insulation panel when the anchoring profile is mounted and thereby retaining the insulation panel in the roof structure.

[0007] By the invention, it is realised that a roof structure with an anchoring profile may be provided where no machining of the upper surface of the insulation panel is required in order to mount the profiles in the insulation panel of the roof structure whilst providing a rigid insulation mounting in the roof structure. The anchoring profile is designed with an inwardly protruding longitudinal portion which is compressed into the insulation material, which at least on the outer side of the insulation structure has a relative low density, for instance between 50-100 kg/m³, preferably between 75-90 kg/m³.

[0008] By providing an insulation with a relative soft upper layer. The anchoring profiles can be placed directly on the insulation panel surface and the protruding portion of the profile is pressed into the insulation and secured to the support structure by the connecting elements of the anchoring means.

[0009] The insulation material may be of any suitable type, e.g. foam or fibrous insulation material, such as mineral wool, especially rock wool or glass wool. A fibrous insulation material is often preferred.

[0010] In the preferred embodiment, the connecting elements are anchoring screws for securing the profiles to the support structure. Accordingly, the profile is preferably provided with apertures at a predetermined distance for receiving the anchoring screws. However, it is realised that other suitable means of attachment may be used.

[0011] Preferably, the retention and protruding portions are integrally formed in the anchoring profile as a one-piece structure. However, it is realised that alternatively, the retention and protruding portions may be formed in separate sub-profiles, which are assembled to the anchoring profile.

[0012] The anchoring profile may be formed in a metal sheet which is bend into a predetermined shape, where the metal sheet has a thickness of 0.75-1.75 mm, preferably approx. 1.2 mm. Hereby, an suitable anchoring profile may be produced at relative low costs.

[0013] Preferably, the anchoring profile is symmetric along its longitudinal axis. Hereby, the profile is prevented from tilting when mounted on the roof structure.

[0014] In a first embodiment, the profile has a centrally disposed, inwardly protruding profile portion with a reten-

tion portion on each side thereof. Preferably, the inwardly protruding portion consists of a base portion disposed generally parallel to the retention portions and two upright portions connecting the base portion with a retention portion on each side thereof. This geometric shape provides a profile with a good stiffness as well as being easy to mount, i.e. slightly compress the upper layer of the insulation.

[0015] In a preferred embodiment of the invention, the base portion is provided with anchoring holes for the connecting elements. By providing the holes in the base portion, the connecting element may extend into the space inside the protruding profile portion if the roof structure is compressed, e.g. by walking on the roof structure during its construction. Accordingly, the two upright portions of the profile and the retention portions protect the anchoring screw from being damaged.

[0016] In an embodiment, the side edges of the profile are bend downwards in order to provide extra stiffness.

[0017] According to a preferred embodiment of the invention, the anchoring profile is a stackable profile. By providing the profile with bending angles different than 90° between the upright portions and the base portion, the upright portions and the retention portions and the retention portions and the side edge portions, the profile becomes stackable.

[0018] According to a second embodiment of the invention, the profile has a central retention portion with inwardly protruding portions on each side thereof.

[0019] In an embodiment of the invention, the fibrous insulation panel is a dual-density fibrous insulation panel having a first layer having a relative low density facing outwards and a high-density layer inwards. Hereby, the outermost layer is relatively easily compressible and the innermost layer of the insulation sufficiently stiff to withstand the roof load.

[0020] Preferably, the low-density layer in the dual density fibrous insulation panel is provided with a density between 50-100 kg/m³, preferably between 75-90 kg/m³.

[0021] Furthermore, the high-density layer in the dual density fibrous insulation panel is preferably provided with a density of 50-150 kg/m³, preferably 90-120 kg/m³.

[0022] Alternatively, the fibrous insulation panel has a uniform density of 60-150 kg/m³, preferably between 80-120 kg/m³.

[0023] The easily compressible outer layer of the insulation may also be achieved by giving the outer layer a treatment, e.g. a mechanical treatment, making it more flexible or resilient. This could be the application of rollers compressing the outer layer in order to softening this, as described in WO 03/042445. Another method for providing a more flexible or softer outer layer could be to add a less amount of binder to the outer layer. A further method is to manipulate the fibre orientation, e.g. by having a fibre orientation in the top layer substantially parallel to the major surfaces of the insulation and in the lower layer having a fibre orientation substantially perpendicular to the major surface. The fibre orientation can be manipu-

lated by different methods applied on both the primary web and the secondary web on the production line. This is described in further details in WO 97/36035.

[0024] Obviously, it will also be possible to obtain the compressible top layer by combining different insulation products. This may be two or more different insulation materials.

[0025] Preferably, the layer of fibrous insulating material comprises rectangular panels. Other shapes may also be used, e.g. a number of wedge-shaped panels, in particular cut-to-fall slabs.

[0026] Elongated apertures may be provided in the profiles through which the anchoring screws are mounted. Hereby, expansions of the anchoring profiles due to thermal impacts will not bend the anchoring elements, i.e. the screws. This means that the anchoring screws are not weakened in strength, which in turn means that less screws are needed in order to provide the necessary anchoring force in order to achieve a good lifetime of the roof construction. By using a less amount of anchoring screws for securing the insulation to the support structure better acoustic properties and heat insulation properties are achieved, as the reduced number of anchoring points results in a reduction of noise and heat transfer points through the insulation layer. This makes a roof system particularly suitable for roof constructions on buildings in noisy environments, such as airport terminals and the like.

[0027] In an alternative embodiment, the elongated apertures may be provided as slits in the profile. The anchoring screws may open the slits at the point of actual mounting and penetrate through the slit and the insulation layer for being anchored to the support structure.

[0028] The support structure may be a corrugated sheet, such as a trapezium sheet, a concrete panel section or a wooden construction.

[0029] The top structure may be any kind of outer covering, such as roof panels, tiles, with or without extra insulation on top of the sub-roof structure according to the invention.

[0030] In the following, the invention is described in detail with reference to the accompanying drawings, in which

- 45 Fig. 1 is a cross-section view of a roof structure according to the prior art;
- Fig. 2 is a perspective partial view of a double layer roof structure according to the invention;
- 50 Fig. 3 is a cross-section view of the double layer roof according to the invention;
- Fig. 4 is a detailed cross-section view of a the roof system according to a preferred embodiment of the invention;
- 55 Fig. 5 is a cross-section view of an anchoring profile according to a first embodiment of the invention;
- Fig. 6 is a variation of the anchoring profile in

- fig. 5;
 Fig. 7 shows a stack of anchoring profiles of fig. 6;
 Fig. 8 is a schematic top-view of the anchoring profile of fig. 5 or 6;
 Figs. 9 to 15 show other embodiments of anchoring profiles according to the invention.

[0031] A roof structure of the kind shown in fig. 1 is known in the art. Such double layer roof system comprises a support structure 5, such as a trapezium sheet mounted on a generally planar underlying wall or roof panel 8 (see fig. 3). A vapour barrier 6 may be positioned between the support structure 5 and the insulation material 1.

[0032] A layer of insulation material 1 is positioned on the support structure 5 and retained in this position by anchoring means. These anchoring means includes anchoring profiles 2, which are positioned across the upper side of the insulation material 1 and secured to the underlying support structure 5 via a number of anchoring screws 3 extending through the insulation material 1. The support structure 5 may be a trapezium sheet, a corrugated metal sheet, a concrete wall section, a wooden support structure or any other suitable roof or wall panel structure.

[0033] In the roof construction according to the prior art shown in fig. 1, the insulation material 1 is preferably a dual-density type fibrous insulation panel where the upper layer of the panel is provided with a higher density than the lower. The anchoring profile 2 is U-shaped. The profile 2 is inserted into two machined grooves 9 in the insulation panel 1 preferably so that the high-density layer 14 is not perforated by the downwardly protruding wings of the profile 2.

[0034] A top structure 4 is mounted onto the anchoring profiles 2. An intermediate sheet panel 7 may be provided between the profiles 2 and the top structure 4 which may be a sheet panel system, e.g. trapezium sheets or other top mounted structures, including e.g. solar panels or the like. Alternative to the metal top structure, the top structure 4 may be a foil or similar non-metallic covering which is secured to the profiles 3 in a suitable manner.

[0035] The U-shaped anchoring profiles 2 are provided with a certain distance from each other. If an intermediate panel 7 is mounted on the profiles 2, the top structure 4 need not necessarily be fixed to the profiles 2 but may be fixed to the panel 7. This provides a great flexibility in the top structure mounting.

[0036] As shown in figs. 2 to 4, the need for machining grooves for the anchoring profiles is not needed by a roof structure according to the invention, as the anchoring profile 2 is pressed into the upper side of the fibrous insulation layer 1. The anchoring profiles 2 are mounted to the support structure 5 by anchoring screws 3 which extend through the insulation material 1. Due to the shape of the anchoring profile 2, the profiles 2 are held in a predetermined position when mounted and fixate the in-

5 insulation panels in their place. The elasticity of the fibrous insulation panel 1 provides a stabile roof structure as the profiles 2 are pressed outwards once they are mounted to the support structure 5 by the anchoring screws 3. This provides a stabile and sturdy roof structure, which serves as a base structure (sub-roof structure) for the outermost top structure 4, 7 of the roof.

[0037] As shown in fig. 4, the fibrous insulation panel 1 is preferably a dual-density insulation panel where the top layer 1a has a low density and the bottom layer 1b has a high density. The low-density layer 1a preferably has a density between 50-100 kg/m³, most preferably, between 75-90 kg/m³, and high-density layer 1b in the dual density fibrous insulation panel 1 is preferably provided with a density of 70-150 kg/m³, preferably 90-120 kg/m³.

[0038] With reference to fig. 5 and 8, the anchoring profile 2 is provided with an inwardly protruding profile portion 22, which is defined by a base portion 23 and two upright portions 24 of each side of said base portion 23. The height of the profile 2, i.e. the length of the upright portions 24 is preferably approximately 16 mm. On each side of the central protruding portion 22, retention portions 21 are provided. On the outer edges thereof, edge portions 25 are bend downwards to provide extra stiffness to the profile 2. In the base portion 23, which is the innermost portion of the profile 2, a number of anchoring holes 26 may be provided. These anchoring holes 26 may be circular or elongated in shape. This means that no drilling is needed during the mounting. The profile 2 is produced from a metal strip with a thickness of between 0.75-1.75 mm, e.g. approx. 1.2 mm by bending the profile 2 into the predetermined shape. The profile 2 is symmetrically shaped so that it does not tilt when mounted in the insulation. Accordingly, the anchoring holes 26 are provided in the symmetry line.

[0039] Hereby, a good stiffness of the profile 2 is provided just as protection of the anchoring screws 3 (see figs. 2 to 4) is provided and the risk of damaging the top structure if the roof is heavily loaded may be avoided, e.g. by extreme snow loads where the top roof structure 4 is pressed downwards and compresses the fibrous insulation panel 1. Moreover, during the roof construction, the roof structure as well as the workers walking on the roof are protected from damaging the roof construction due to the stiffness of the profiles and the mounting screws 3 are not bend or damaged just as the workers are not hurt by protruding anchoring screws.

[0040] As shown in fig. 6, the profile 2 may be produced with bendings of less than or more than 90°, at least by the bend angle between the base portion 23 and the two upright portions 24. Hereby, the profiles 2 become stackable as shown in fig. 7. This makes it easier to transport the profiles 2 to a building site and up on the roof. The angular displacement relative to the right angle of the bend may in a preferred embodiment be such that once installed in the insulation material, the profile 2 is bend into the shape shown in the dotted line in fig. 6. The profile

2 may be bend into this "dotted shape" by the elasticity of the fibrous insulation material when the profile 2 is mounted as shown in e.g. fig. 4.

[0041] In fig. 9, a second embodiment of an anchoring profile in a roof structure according to the invention is shown. This design of the profile 2 is provided with a central retention portion 21 and two protruding portions 22 on each side thereof. In the symmetry line, anchoring holes 26 are provided. As indicated in the figure, the profile 2 is mounted on the fibrous insulation panel 1 and compresses the insulation at the two locations of the protruding profile portions 22 and the anchoring profile 2 is fixed to the support structure (not shown in fig. 9) at the centre of the profile 2, so that the elasticity of the insulation 1 does not tilt the profile 2 once it is mounted.

[0042] The embodiment of the anchoring profile 2 shown in fig. 10 is an assembled profile, where the horizontal retention portion 21 is provided in one sub-profile and the inwardly protruding portion 22 is provided in a second sub-profile. The two sub-profiles are assembled by suitable means 28, e.g. rivets or bolts. Centrally in the symmetry line anchoring holes are provided in both sub-profiles for receiving the anchoring screw 3.

[0043] In fig. 11 a variant of the profile 2 of figures 2 to 8 is shown, where no side edge portions are provided. This profile 2 of fig. 11 is more simple and suitable if less stiffness is required.

[0044] A further embodiment of an anchoring profile for a roof structure according to the invention is shown in fig. 12. According to this embodiment, a metal strip 27 is bent into a substantially rectangular shape and provided with centrally disposed anchoring holes 26 for mounting the profile 2 in the roof structure. In this embodiment, the basic functions of the retention portion (positioning) and the protruding portions (bending strength) are integrated into the rectangular profile shape.

[0045] A further embodiment is shown in fig. 13, where the protruding portion 22 is semicylindrical in shape. According to the embodiment of fig. 14, the protruding portion 22 may be wedge-shaped. In another embodiment, the profile may be T-shaped as shown in fig. 15.

[0046] The anchoring holes 26 of the anchoring profiles 2 in the figures are circular in shape. However, it is realised that elongated openings or slits may be provided. This provides the advantage of preventing thermal expansion to cause stress on the anchoring screws.

[0047] In the drawings, the invention is described with relation to a double layer roof structure, i.e. where the upper section of the roof structure comprises a metal roof or the like, e.g. a trapezium/corrugated sheet. However, the invention may also concern any other top roof construction.

[0048] In the specification terms like outside or inside, above or below, or similar relative terms relating to the roof and/or the insulation merely relates to the warm or the cold side of the insulation, e.g. the warm side being the inside of the roof and vice versa. Thus, the roof structure according to the invention may be used for vertical

structures, i.e. side or end walls of a building, flat roofs or inclined roof structures.

5 Claims

1. A roof structure with a insulating panel assembly, said roof structure including an insulation layer (1) of insulating material, which is mounted onto a support structure (5) by anchoring means including at least one of longitudinal anchoring profile (2) on the outside of the insulating material layer (1) for retaining the insulation layer (1) and for supporting a top panel structure (4), which may be secured to said at least one profile (2), which are secured to the support structure (5) through the insulation layer (1) by connecting elements (3),

characterised in that

said at least one anchoring profile (2) comprises at least one profile retention portion (21) having a resting surface, which rests on the outer surface of the insulation panel (1), and

at least one longitudinally oriented inwardly protruding profile portion (22) and that at least the outer portion of the insulation panel (1) is being soft, so that the inwardly protruding portion (22) locally compress the insulation panel (1) when the anchoring profile (2) is mounted and thereby retaining the insulation panel (1) in the roof structure.

2. A roof structure according to claim 1, wherein the insulation panel (1) comprises a fibrous insulation material, preferably mineral wool.

3. A roof structure according to claim 1 or 2, wherein the connecting elements are anchoring screws (3) for securing the profile (2) to the support structure (5).

4. A roof structure according to any of the preceding claims, wherein the profile (2) is provided with apertures (26) for receiving the anchoring screws (3).

5. A roof structure according to any of the preceding claims, wherein the retention and protruding portions (21, 22) are integrally formed in the anchoring profile (2) as a one-piece structure.

6. A roof structure according to any of the preceding claims, wherein the anchoring profile (2) is formed in a metal sheet which is bend into a predetermined shape.

7. A roof structure according to claim 6, wherein the metal sheet has a thickness of 0.75-1.75 mm, preferably approx. 1.2 mm.

8. A roof structure according to claim 1 to 4, wherein the retention and protruding portions (21, 22) are

formed in separate sub-profiles, which are assembled to the anchoring profile (2).

9. A roof structure according to any of the preceding claims, wherein the anchoring profile (2) is symmetric along its longitudinal axis. 5
10. A roof structure according to any of the preceding claims, wherein the profile (2) has a centrally disposed, inwardly protruding profile portion (22) with a retention portion (21) on each side thereof. 10
11. A roof structure according to claim 10, wherein the inwardly protruding portion (22) consists of a base portion (23) displaced to the retention portions (21) and two upright portions (24) connecting the base portion (23) with a retention portion (21) on each side thereof. 15
12. A roof structure according to claim 11, wherein the base portion (23) is provided with anchoring holes (26) for the connecting elements (3). 20
13. A roof structure according to claim 12, wherein the anchoring holes (26) are elongated holes or slits, preferably in the longitudinal direction of the profile. 25
14. A roof structure according to any of claims 11 to 13, wherein the side edges (25) of the profile (2) are bend downwards. 30
15. A roof structure according to any of claims 11 to 14, wherein the anchoring profile (2) is a stackable profile. 35
16. A roof structure according to any of claims 1 to 9, wherein the profile (2) has a central retention portion (21) with inwardly protruding portions (22) on each side thereof. 40
17. A roof structure according to any of the preceding claims, wherein the fibrous insulation panel (1) is a dual-density fibrous insulation panel having a first layer (1a) having a relative low density facing outwards and a high-density layer (1b) inwards. 45
18. A roof structure according to claim 17, wherein said low-density layer (1a) in the dual density fibrous insulation panel (1) is provided with a density between 50-100 kg/m³, preferably between 75-90 kg/m³. 50
19. A roof structure according to claim 17, wherein said high-density layer (1b) in the dual density fibrous insulation panel (1) is provided with a density of 70-150 kg/m³, preferably 90-120 kg/m³. 55
20. A roof structure according to any of claims 1 to 16, wherein the fibrous insulation panel (1) has a uniform density of 60-150 kg/m³, preferably between 80-120 kg/m³.
21. A roof structure according to any of claims 1 to 16, wherein the fibrous insulation panel (1) is provided with a soft outermost layer by subjecting the insulation panel to a mechanical treatment of the surface, e.g. by one or more rollers or the like.
22. A roof structure according to any of claims 1 to 16, wherein the fibrous insulation panel (1) is provided with a soft outermost layer by providing a lower binder content in the outer portion of the fibrous insulation panel.
23. A roof structure according to any of claims 1 to 16, wherein the fibrous insulation panel (1) is provided with a soft outermost layer by providing a fibre orientation in the outer portion which is substantially parallel to the major surfaces of the insulation.
24. A roof structure according to any of the preceding claims, wherein the layer of fibrous insulating material comprises rectangular panels (1).
25. A roof structure according to any of the preceding claims, wherein the layer of insulating material comprises a number of wedge-shaped panels, in particular cut-to-fall slabs.
26. A roof structure according to any of the preceding claims, wherein the support structure (5) is a corrugated sheet, such as a trapezium sheet.
27. A roof structure according to any of the preceding claims, wherein the support structure (5) is a concrete panel section.
28. A roof structure according to any of the preceding claims, wherein the support structure (5) is a wooden construction.

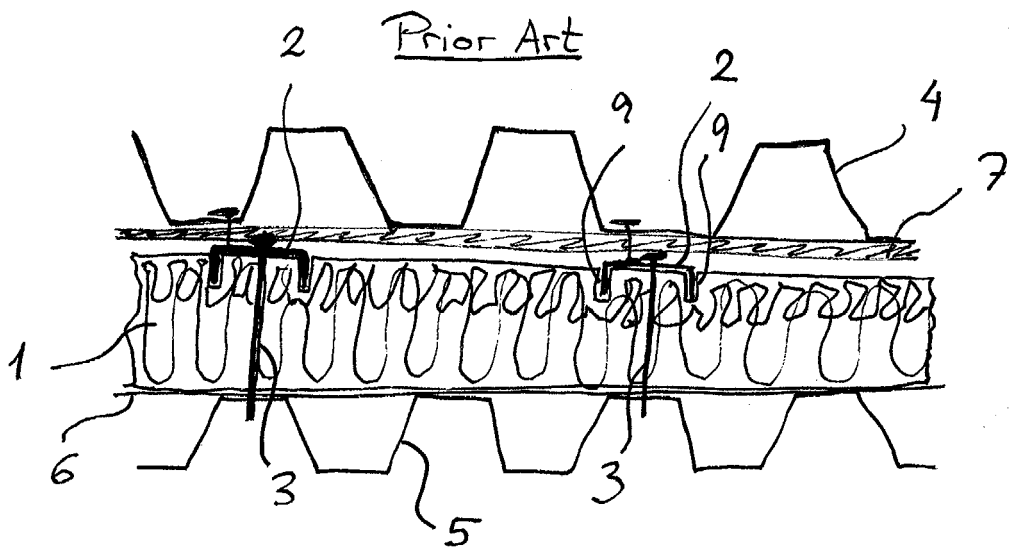

Fig. 1

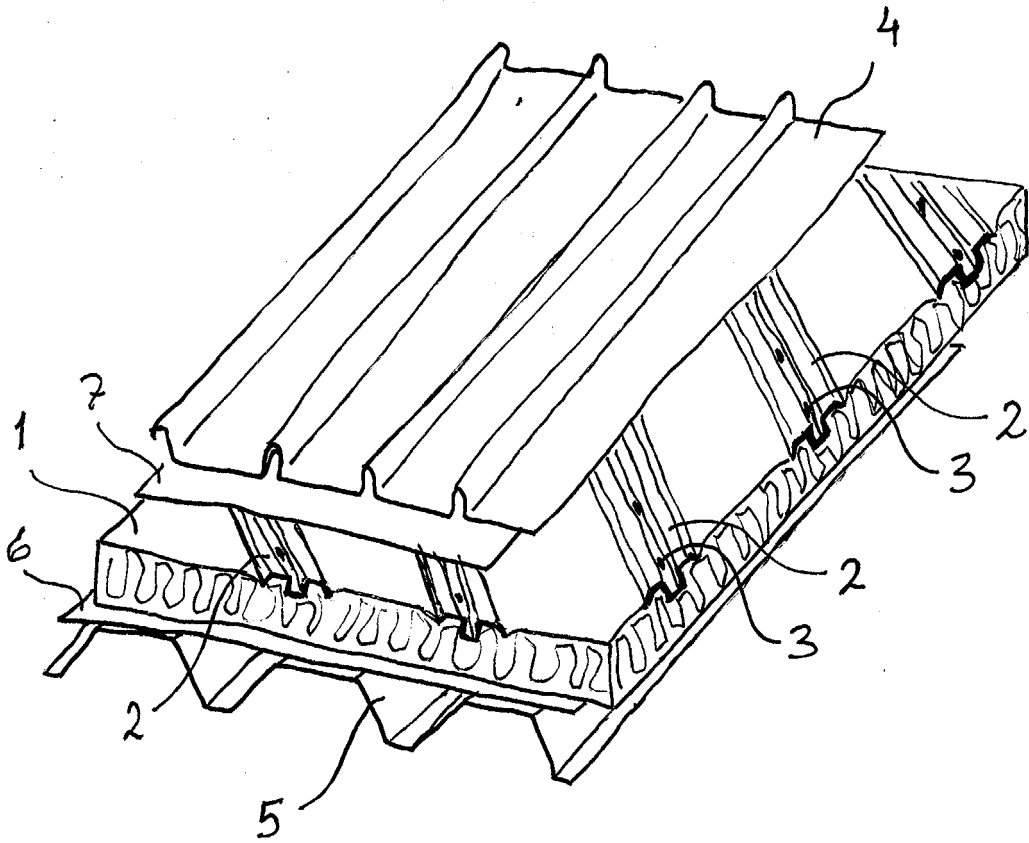

Fig. 2

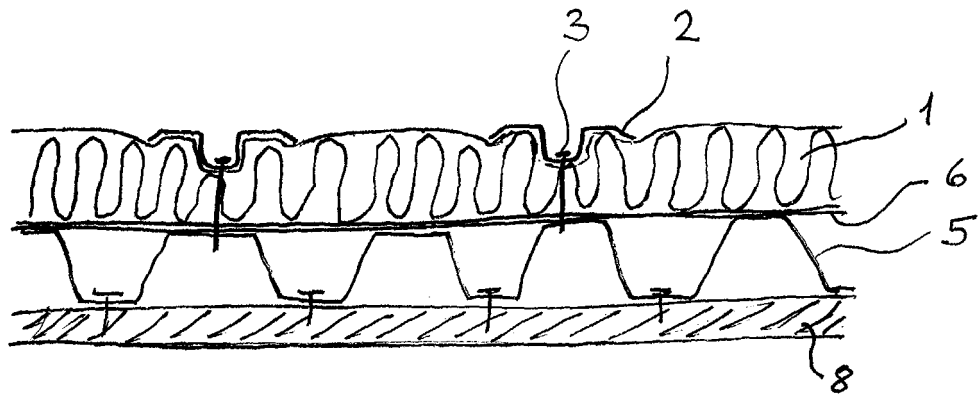

Fig. 3

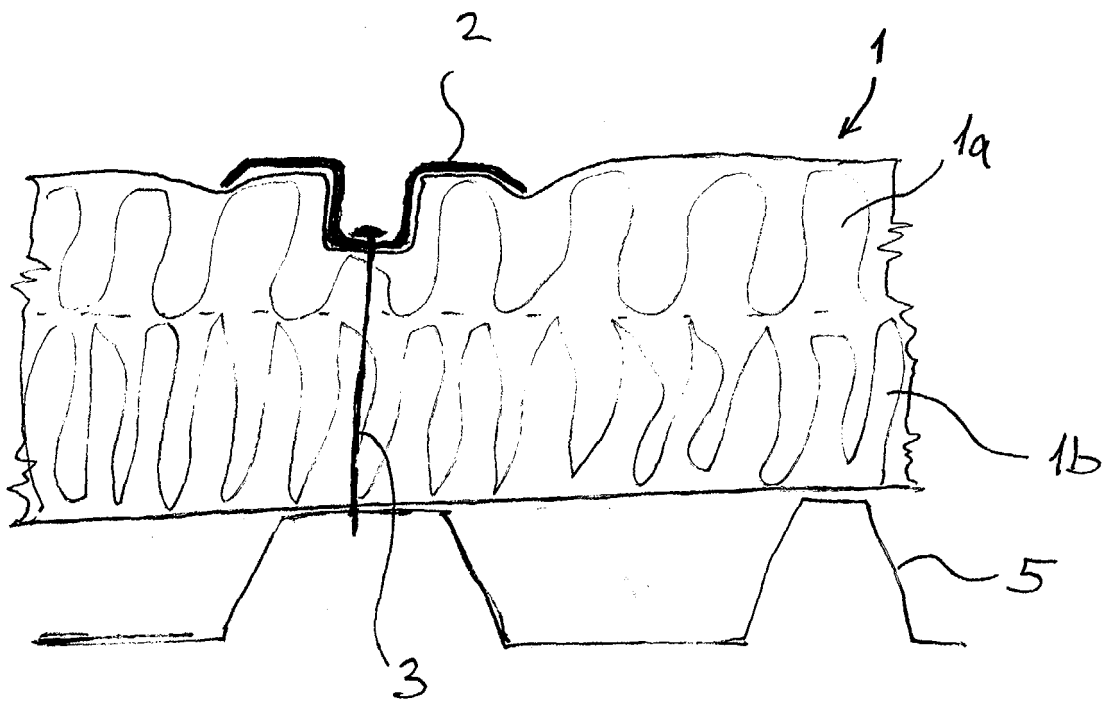
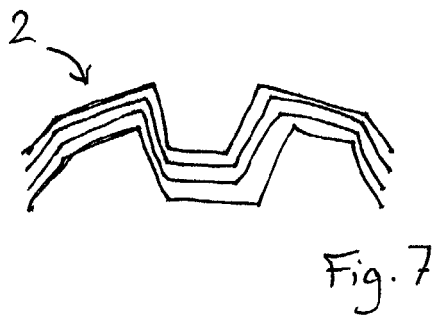
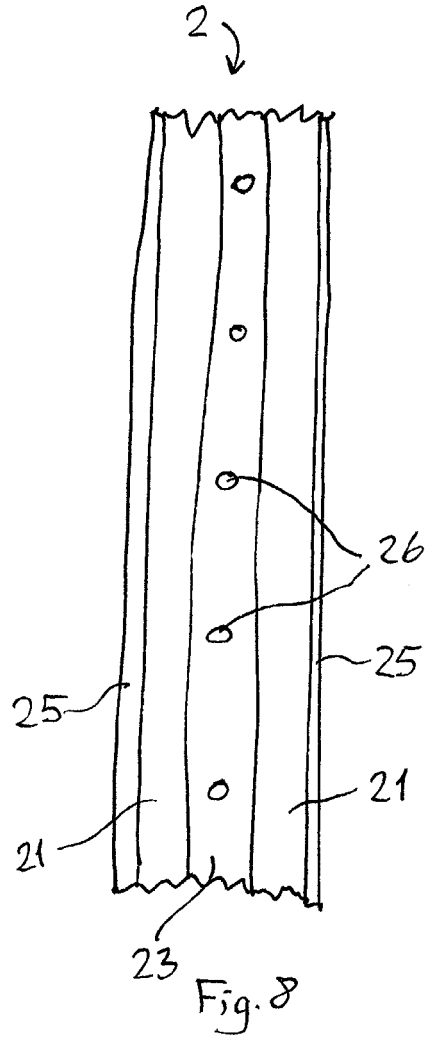
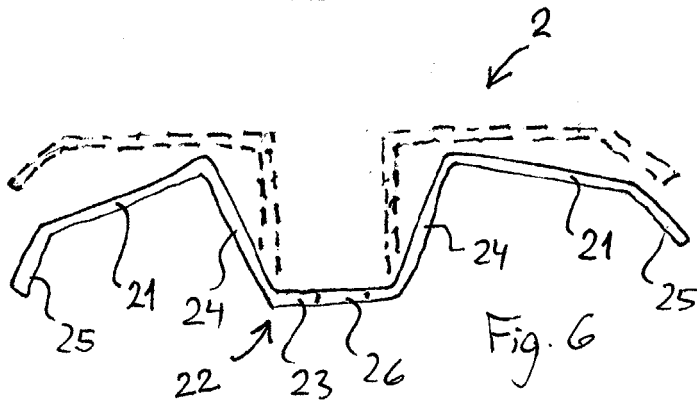
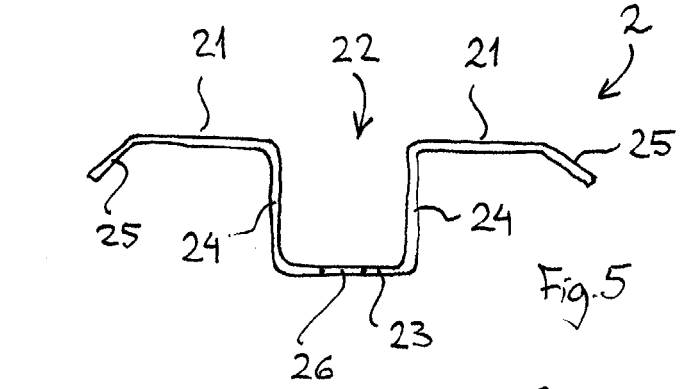
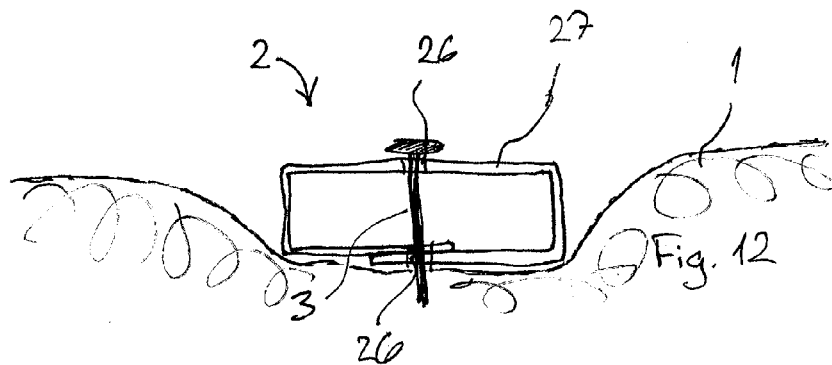
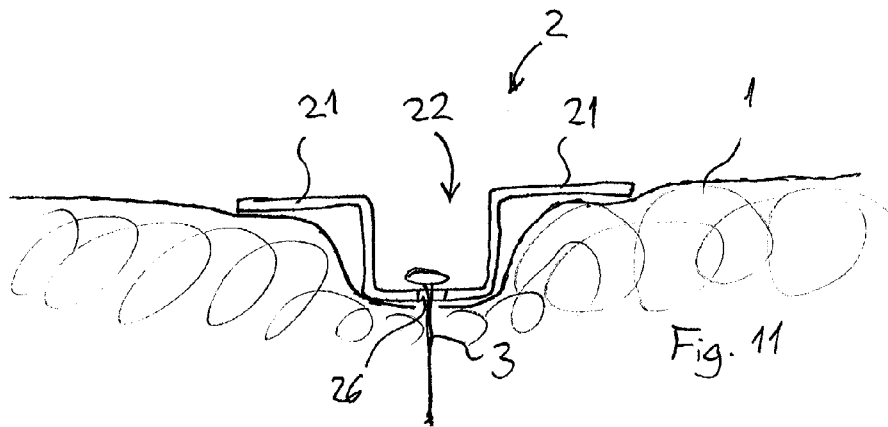
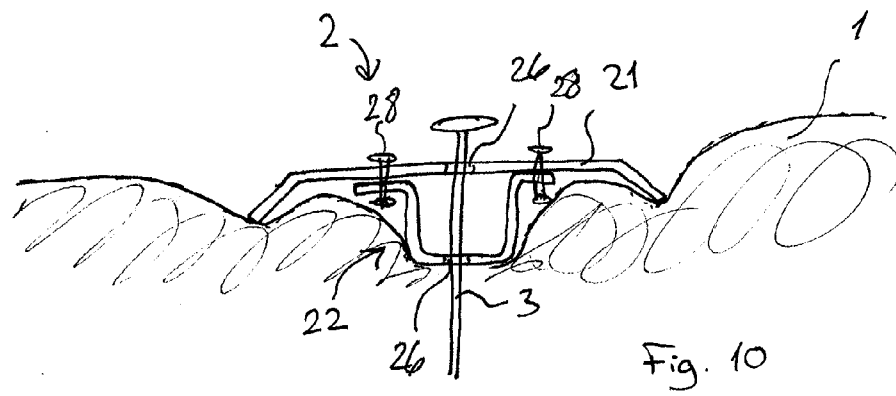
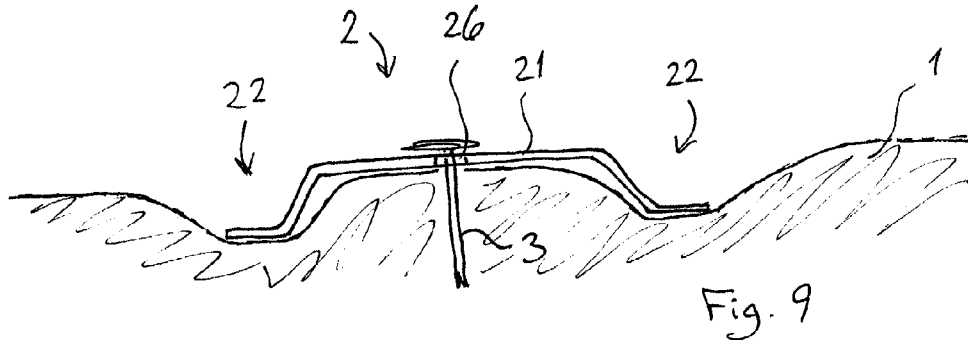

Fig. 4





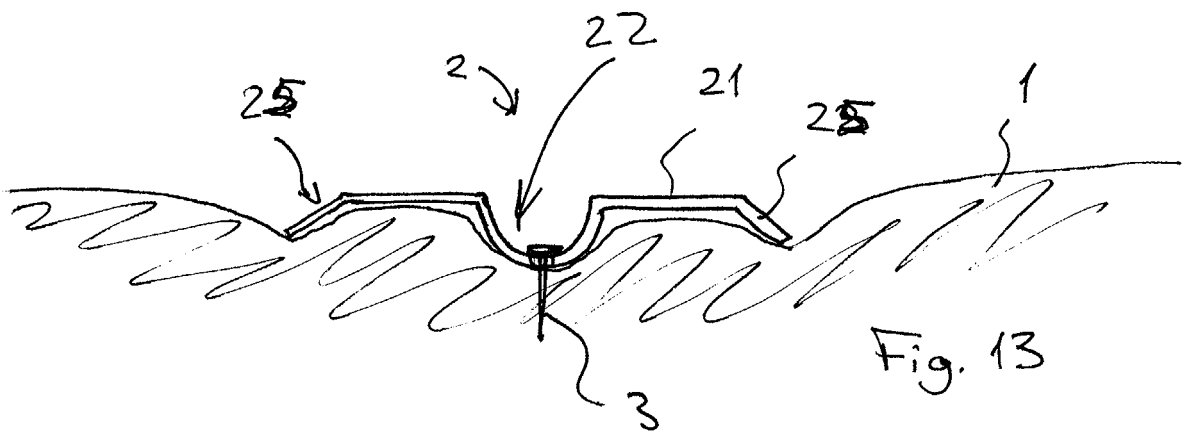

Fig. 13

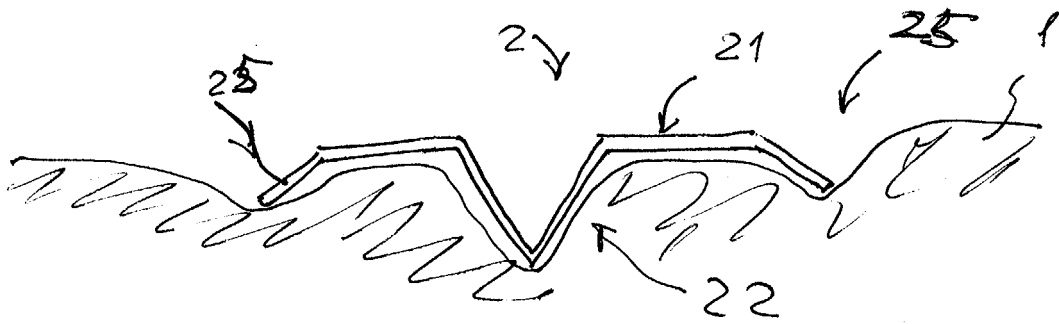

Fig. 14

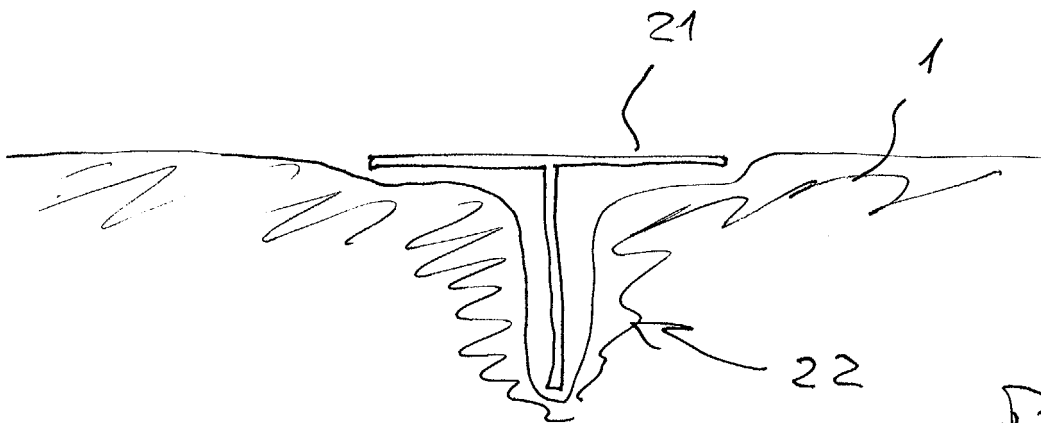

Fig. 15



DOCUMENTS CONSIDERED TO BE RELEVANT			
Category	Citation of document with indication, where appropriate, of relevant passages	Relevant to claim	CLASSIFICATION OF THE APPLICATION (Int.Cl.7)
X	EP 1 333 131 A (ARCHITECTURAL PROFILES LIMITED) 6 August 2003 (2003-08-06) * figures 2-4,12 *	1-7, 20-23,26	E04D13/16
X	EP 0 011 202 A (H.H.+ROBERTSON COMPANY; H.H. ROBERTSON COMPANY) 28 May 1980 (1980-05-28) * page 9, last paragraph - page 10, paragraph 2; figures 1,9,8 *	1,2,5-7, 9,16, 20-23,26	
X	EP 0 984 114 A (DEUTSCHE ROCKWOOL MINERALWOLL GMBH & CO. OHG; DEUTSCHE ROCKWOOL MINERA) 8 March 2000 (2000-03-08) * paragraphs [0051], [0069]; figure 6 *	1-7, 10-14, 24-26	
X	EP 0 685 612 A (PROECKL, GERTHOLD, DIPL.-ING) 6 December 1995 (1995-12-06) * column 3, line 33 - line 46; figures * * column 2, line 41 *	1-7,9, 16,20, 24-26 17-19	
Y	FR 2 849 884 A (CORUS BAUSYSTEME GMBH) 16 July 2004 (2004-07-16) * page 3, line 18 - line 35; figure 5 *	17-19	TECHNICAL FIELDS SEARCHED (Int.Cl.7)
A	FR 2 702 542 A (COUVRACIER SA; ROCKWOOL ISOLATION SA) 16 September 1994 (1994-09-16) * page 5, line 14 - page 6, line 2; figures 1,2 *	17-19	E04D
A	EP 1 179 645 A (SAINT-GOBAIN ISOVER) 13 February 2002 (2002-02-13) * paragraph [0010]; figures 3,4 *	17-23	
The present search report has been drawn up for all claims			
Place of search		Date of completion of the search	Examiner
The Hague		8 March 2005	Demeester, J
CATEGORY OF CITED DOCUMENTS			
X : particularly relevant if taken alone Y : particularly relevant if combined with another document of the same category A : technological background O : non-written disclosure P : intermediate document		T : theory or principle underlying the invention E : earlier patent document, but published on, or after the filing date D : document cited in the application L : document cited for other reasons & : member of the same patent family, corresponding document	

2

EPO FORM 1503 03 82 (P04C01)

ANNEX TO THE EUROPEAN SEARCH REPORT
ON EUROPEAN PATENT APPLICATION NO.

EP 04 07 7722

This annex lists the patent family members relating to the patent documents cited in the above-mentioned European search report. The members are as contained in the European Patent Office EDP file on
The European Patent Office is in no way liable for these particulars which are merely given for the purpose of information.

08-03-2005

Patent document cited in search report		Publication date		Patent family member(s)	Publication date
EP 1333131	A	06-08-2003	EP	1333131 A1	06-08-2003
			GB	2384792 A ,B	06-08-2003

EP 0011202	A	28-05-1980	CA	1068870 A1	31-12-1979
			CA	1068871 A2	31-12-1979
			DE	2963624 D1	28-10-1982
			DK	488679 A	18-05-1980
			EP	0011202 A1	28-05-1980
			NO	793693 A	20-05-1980

EP 0984114	A	08-03-2000	DE	19840076 A1	23-03-2000
			EP	0984114 A2	08-03-2000

EP 0685612	A	06-12-1995	DE	4418890 A1	14-12-1995
			AT	149609 T	15-03-1997
			DE	59500123 D1	10-04-1997
			DK	685612 T3	15-09-1997
			EP	0685612 A1	06-12-1995

FR 2849884	A	16-07-2004	WO	2004063489 A1	29-07-2004
			FR	2849884 A1	16-07-2004

FR 2702542	A	16-09-1994	FR	2702542 A1	16-09-1994

EP 1179645	A	13-02-2002	FR	2779164 A1	03-12-1999
			AT	218658 T	15-06-2002
			AT	280286 T	15-11-2004
			CZ	9802459 A3	17-03-1999
			CZ	9802460 A3	17-03-1999
			DE	19807016 A1	11-02-1999
			DE	29802495 U1	16-04-1998
			DE	29825035 U1	09-06-2004
			DE	69805710 D1	11-07-2002
			DE	69805710 T2	02-10-2003
			DE	69827084 D1	25-11-2004
			DE	896106 T1	04-11-1999
			DK	896106 T3	07-10-2002
			EP	1179645 A2	13-02-2002
			EP	0896106 A2	10-02-1999
			EP	0896110 A2	10-02-1999
			ES	2178084 T3	16-12-2002
			PT	896106 T	31-10-2002
			SI	896106 T1	31-12-2002

EPO FORM P0459

For more details about this annex : see Official Journal of the European Patent Office, No. 12/82