

(12) PATENT
(19) AUSTRALIAN PATENT OFFICE

(11) Application No. AU 199868855 B2
(10) Patent No. 740367

(54) Title
Modular humeral prosthesis

(51)⁷ International Patent Classification(s)
A61F 002/40

(21) Application No: **199868855**

(22) Application Date: **1998.04.03**

(87) WIPO No: **WO98/46172**

(30) Priority Data

(31) Number	(32) Date	(33) Country
9707371	1997.04.11	GB

(43) Publication Date : **1998.11.11**

(43) Publication Journal Date : **1998.12.24**

(44) Accepted Journal Date : **2001.11.01**

(71) Applicant(s)
Smith and Nephew, Inc.

(72) Inventor(s)
Paul M. Dews

(74) Agent/Attorney
DAVIES COLLISON CAVE, 1 Little Collins Street, MELBOURNE VIC 3000

(56) Related Art
EP 679375
US 5358526
WO 95/22302



(51) International Patent Classification ⁶ :
A61F 2/40

A1

(11) International Publication Number: **WO 98/46172**

(43) International Publication Date: 22 October 1998 (22.10.98)

(21) International Application Number: PCT/US98/06771

(22) International Filing Date: 3 April 1998 (03.04.98)

(30) Priority Data:
9707371.2 11 April 1997 (11.04.97) GB

SMITH + NEPHEW, INC.

(71) Applicant: ~~MINNESOTA MINING AND MANUFACTURING COMPANY [US/US]; 3M Center, P.O. Box 33427, Saint Paul, MN 55133-3427 (US). 1450 Brooks Road Memphis TN 38116~~

(72) Inventor: DEWS, Paul, M.; P.O. Box 33427, Saint Paul, MN 55133-3427 (US).

(74) Agents: BAUER, Stephen, W. et al.; Minnesota Mining and Manufacturing Company, Office of Intellectual Property Counsel, P.O. Box 33427, Saint Paul, MN 55133-3427 (US).

(81) Designated States: AL, AM, AT, AU, AZ, BA, BB, BG, BR, BY, CA, CH, CN, CU, CZ, DE, DK, EE, ES, FI, GB, GE, GH, GM, GW, HU, ID, IL, IS, JP, KE, KG, KP, KR, KZ, LC, LK, LR, LS, LT, LU, LV, MD, MG, MK, MN, MW, MX, NO, NZ, PL, PT, RO, RU, SD, SE, SG, SI, SK, SL, TJ, TM, TR, TT, UA, UG, UZ, VN, YU, ZW, ARIPO patent (GH, GM, KE, LS, MW, SD, SZ, UG, ZW), Eurasian patent (AM, AZ, BY, KG, KZ, MD, RU, TJ, TM), European patent (AT, BE, CH, CY, DE, DK, ES, FI, FR, GB, GR, IE, IT, LU, MC, NL, PT, SE), OAPI patent (BF, BJ, CF, CG, CI, CM, GA, GN, ML, MR, NE, SN, TD, TG).

Published
With international search report.



(54) Title: MODULAR HUMERAL PROSTHESIS

(57) Abstract

A modular humeral prosthesis for replacement of the humeral head of a humerus (20). The prosthesis generally comprises a stem (10) to be fitted to a resected humerus (20); a head (22) sized and configured to approximate the humeral head; and an intermediate connecting member (24) for connecting the stem (10) to the head (22). A first engagement/mounting portion (26) is provided on the intermediate connecting member (24) for mounting the intermediate connecting member (24) on the stem (10), and a second engagement/mounting portion (28) is provided on the intermediate connecting member (24) for mounting the head (22) on the intermediate connecting member (24). The first engagement/mounting portion (26) has an axis about which the intermediate connecting member (24) can be rotated through 360° relative to the stem (10) and thereafter secured at a selected relative orientation. The second engagement/mounting portion (28) has an axis about which the head (22) can be rotated through 360° relative to the intermediate connecting member (24) and thereafter secured at a selected relative rotation. The axes of rotation of the first and second engagement/mounting portions are not coincident, whereby the first and second engagement/mounting portions allow the head (22) to be given a desired offset relative to the stem (10). Also disclosed is a modular humeral prosthesis kit comprising a variety of different intermediate connecting members (24, 24a-f) that may be selected to fit the prosthesis to the patient, and a method of replacing a humeral head in a patient.

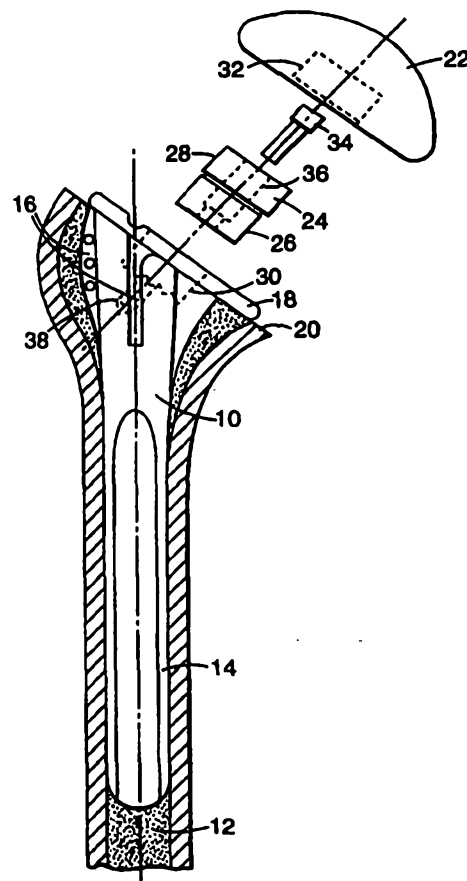

MODULAR HUMERAL PROSTHESIS

This invention relates to a modular humeral prosthesis.

Background of the Invention

5 During the procedure of a shoulder replacement operation, at least a portion of the proximal section of the humeral shaft will be replaced by a metal prosthesis. This prosthesis will generally consist of two parts: a stem that is mounted into the medullary canal of the humerus, and a head component connected in some manner to the stem. The head component replaces the bearing
10 surfaces of the humerus and articulates with the surface of the scapula to allow the movement of the shoulder.

 Modular humeral prostheses are known. The stem and head component may be supplied in "modular" form, that is, as separate connectable components. Different stem sizes and head sizes in a modular implant design
15 provide the surgeon with some degree of inter-operative flexibility, which facilitates reconstruction of the original anatomy of the patient.

 With a range of stem sizes and a range of head sizes available, the surgeon can choose a particular combination to suit the anatomy of each individual patient without having to have a large inventory of "integral" or "unitary" humeral
20 prosthesis. As used herein, "integral" and "unitary" mean formed in one continuous piece in contrast to the separate connectable components of a modular prosthesis. For example, one patient might require a relatively small head and a relatively long stem. With a unitary prosthesis a wide range of stem lengths would be required for each head size whereas with a modular arrangement a particular
25 head can be used with a range of stem sizes and visa versa.

 Additional variations arise also as a result of individual patients requiring differing angles of inclination of the head relative to the stem and of differing offsets between the axis of the head and the axis of the stem. Thus, in one patient the offset may be posterior and in another anterior.

30 Various shoulder prostheses are disclosed in European Patent Publication No. EP-A 0 679 375; EP-A 0 712 617; French Patent No. FR-A 2 664 809; US Patent Nos. 3,694,820; 3,803,641; 4,045,825; 4,106,130; 4,179,758;

4,865,605; 4,919,670; 5,358,526; 5,549,682; 5,462,563 and 5,702,457; and PCT International Patent Publication No. WO 96/17553.

Summary of the Invention

5 This invention provides a modular prosthesis in which a humeral head, chosen to suit a patient, is attached to a stem chosen to suit the resected humerus of the patient by means of an intermediate connecting member. The prosthesis can accommodate a wide range of variation, in a relatively cheap manner, by providing the variations required in the intermediate connecting member rather than in the very much
10 more expensive head.

 According to a first aspect of the present invention there is provided a modular humeral prosthesis for replacement of the humeral head of a humerus, comprising:

 a stem adapted to be fitted to a resected humerus, the stem having a proximal
15 face which in use is adapted to extend generally parallel with the resected surface of the humerus and the stem including a first mating portion for engaging with an intermediate connecting member;

 a head sized and configured to approximate the humeral head, the head including a second mating portion for engaging with an intermediate connecting
20 member; and

 an intermediate connecting member for connecting the stem to the head, the intermediate connecting member including:

 a first engagement portion for mating engagement with the first mating
portion to mount the intermediate connecting member on the stem, the
25 intermediate connecting member being rotatable through 360° relative to the stem about the first mating portion and being securable at a selected relative orientation; and

 a second engagement portion for mating engagement with the second
mating portion to mount the head on the intermediate connecting member, the
30 head being rotatable through 360° relative to the intermediate connecting member about the second engagement portion and being securable at a selected



relative rotation;

wherein the axes of rotation of the first and second engagement portions are not coincident and wherein the arrangement of the stem, the head and the intermediate connecting member is such that a desired offset of the head relative to the stem can be achieved by rotating one or both of the head and the intermediate connecting member through any angle up to 360° relative to the intermediate connecting member and to the stem, respectively.

The modular humeral prosthesis generally comprises a stem to be fitted to a resected humerus, a head sized and configured to approximate the humeral head, and an intermediate connecting member for connecting the stem to the head. The intermediate connecting member includes a first engagement portion for mounting the intermediate connecting member on the stem. The first engagement portion has an axis about which the intermediate connecting member can be rotated through 360° relative to the stem and thereafter secured at a selected relative orientation. The intermediate connecting member further includes a second engagement portion for mounting the head on the intermediate connecting member. The second engagement portion has an axis about which the head can be rotated through 360° relative to the intermediate connecting member and thereafter secured at a selected relative rotation. The axis of rotation of the first and second engagement portions is not coincident, whereby the first and second engagement portions allow the head to be given a desired offset relative to the stem.

Preferably, the first mating portion has an axis which is perpendicular to the proximal face of the stem.

Preferably, the axis of rotation of the first and second engagement portions are not parallel, whereby the engagement means allow a desired inclination of the head relative to the stem.

Also, preferably, the first and second engagement portions of the intermediate connecting member are positioned relative to one another to provide a desired separation between the head and the stem.

The first and second engagement portions of the intermediate connecting member are preferably positioned relative to one another to provide a desired separation



between the head and the stem. Most preferably, the separation or "neck length" between the head and the stem is no greater than 5mm.

Also, preferably, the first and second engagement portions each comprise a male portion, and the head and stem are provided with corresponding mating female portions. Also, the first and second engagement portions each may comprise a female portion, and the head and stem are provided with corresponding mating male portions. Even further, one of the first and second engagement portions may be female and the other of the first and the second engagement portions is male.

Further preferably, the modular humeral prosthesis comprises a threaded fastener being substantially aligned with the axis of the first engagement portion.

The male and female portions preferably each have a substantially circular cross-sections, and a substantially self-locking tapered configuration (i.e., a Morse taper).

Most preferably, a bore is provided through the first and second engagement portions and extends through the intermediate connecting member, and the prosthesis further comprising a fastener inserted through the bore to engage the stem to further secure the intermediate connecting member to the stem.

Even further preferably, the intermediate connecting member does not project beyond the proximal face of the stem. Also, the intermediate connecting member may be substantially completely enclosed between the head and the stem.

In a second aspect of the invention a modular humeral prosthesis kit is provided for replacement of the humeral head of a humerus, comprising:

a stem adapted to be fitted to a resected humerus, the stem having a proximal face which in use is adapted to extend generally parallel with the resected surface of the humerus and the stem including a first mating portion for engaging with an intermediate connecting member;

a head sized and configured to approximate the humeral head, the head including a second mating portion for engaging with an intermediate connecting member; and

a plurality of intermediate connecting members of which one may be selected to connect the stem to the head, each intermediate connecting member including:



a first engagement portion for mating engagement with the first mating portion to mount the intermediate connecting member on the stem, the intermediate connecting member being rotatable through 360° relative to the stem about the first mating portion and being securable at a selected relative orientation; and

5

second engagement portion for mating engagement with the second mating portion to mount the head on the intermediate connecting member, the head being rotatable through 360° relative to the intermediate connecting member about the second engagement portion and being securable at a selected relative rotation;

10

the intermediate connecting members of the kit including:

at least one intermediate connecting member in which the first and second engagement portions have generally parallel and coincident axes;

at least one intermediate connecting member in which the first and second engagement portions have generally parallel but not coincident axes;

15

at least one intermediate connecting member in which the first and second engagement portions have an angle (α) of inclination between one another that is different to the angle of inclination between the first and second engagement portions of another intermediate connecting member of the kit; and

20

at least one intermediate connecting member in which the first and second engagement portions are separated by a different neck length, than the neck length separating the first and second engagement portions of another intermediate connecting member of the kit;

and wherein the arrangement of the stem, the head and the intermediate connecting member is such that a desired orientation of the head relative to the stem can be achieved by rotating one or both of the head and the intermediate connecting member through any angle up to 360° relative to the intermediate connecting member and to the stem, respectively.

25

The kit generally comprises a stem to be fitted to a resected humerus, a head sized and configured to approximate the humeral head, and a plurality of intermediate connecting members of which one may be selected to connect the stem to

30

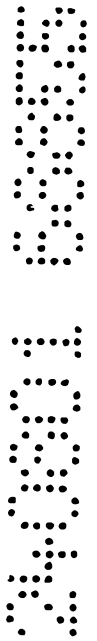

the head. Each intermediate connecting member includes a first engagement portion for mounting the intermediate connecting member on the stem, and a second engagement portion for mounting the head on the intermediate connecting member. The plurality of the intermediate connecting members of the kit include:

- 5 A. At least one intermediate connecting member in which the first and second engagement portions have generally parallel and coincident central axii;
- B. At least one intermediate connecting member in which the first and second engagement portions have generally parallel but not coincident central axii;
- C. At least one intermediate connecting member in which the first
10 and second engagement portions have an angle of inclination between one another that is different than the angle of inclination between the first and second engagement portions of another intermediate connecting member of the kit; and
- D. At least one intermediate connecting member in which the first and second engagement means are separated by a different neck length than the neck
15 length separating the first and second engagement means of another intermediate connecting member of the kit.

The specifications for the plurality of intermediate connecting members set out at A-D above may be met by combining features in some of the intermediate connecting member of the kit. For example, two intermediate connecting members may
20 have different neck lengths, angles of inclination and offsets or zero offset.

The first engagement portion of each intermediate connecting member has an axis about which the intermediate connecting member can be rotated through 360° relative to the stem and thereafter secured at a selected relative orientation, and the second engagement portion of each intermediate connecting member has an axis
25 about which the head can be rotated through 360° relative to the intermediate connecting member and thereafter secured at a selected relative rotation.

Preferably, the first mating portion has an axis which is perpendicular to the proximal face of the stem.

Also, preferably, the first and second engagement means of each
30 intermediate connecting member comprise male portions, and the head and stem are provided with corresponding mating female portions. Also, the first and second



engagement portions each may comprise a female portion, and the head and stem are provided with corresponding mating male portions. Even further, one of the first and second engagement portions may be female and the other of the first and the second engagement portions is male.

5 Further preferably, the modular humeral prosthesis comprises a threaded fastener being substantially aligned with the axis of the first engagement portion.

Most preferably, the male and female portions each have a substantially circular cross-section, and a substantially self-locking tapered configuration (i.e., a Morse taper).

10 Most preferably, each intermediate connecting member is provided with a bore through the first and second engagement portions, and the kit further comprises a fastener inserted through the bore to engage the stem to further secure the intermediate connecting member to the stem.

Even further preferably, the intermediate connecting member does not project beyond the proximal face of the stem. Also, the intermediate connecting member may be substantially completely enclosed between the head and the stem.

There may also be provided a method of replacing a humeral head in a patient. The method generally comprises:

(a) resecting the proximal end of the humerus to remove the head and expose the medullary canal of the humerus;

(b) inserting the stem of a prosthesis into the medullary canal of the resected humerus, the prosthesis being modular and comprising:

a stem;

a humeral head; and

25 one of a plurality of intermediate connecting members for connecting the stem to the head; each intermediate connecting member including:

a first engagement portion between the stem and the intermediate connecting member, the first engagement having an axis about which the intermediate connecting member can be rotated relative to the stem and thereafter secured at a selected relative orientation; and

a second engagement portion between the head and the



intermediate connecting member;

the plurality of intermediate connecting members including connecting members having different inclination angles between the first and second engagement portions and different amounts of offset or no offset between the first and second engagement portions;

(c) selecting a particular intermediate connecting member to provide a desired inclination of the head relative to the axis of a humerus and/or a desired offset of the head; and

(d) setting the intermediate connecting member at an orientation relative to the stem to give the desired inclination of the head relative to the axis of a humerus and/or a desired offset of the head.

Preferably, the plurality of intermediate connecting members includes intermediate connecting members having different neck lengths separating the first and second engagement portions, and the method further comprising selecting an intermediate connecting member to provide a desired separation between the head and the stem.

Most preferably, the plurality of intermediate connecting members each have a bore extending through the intermediate connecting member between the first and second engagement portions, and the method further comprises inserting a fastener into the bore through the second and first engagement means into engagement with the stem to further secure the intermediate member to the stem.

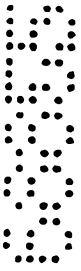

As can be seen, the surgeon will still need his traditional range of head sizes and stem sizes and lengths. However, the surgeon does not need additional heads or stems to provide a particular orientation of the head or a particular offset for the head. Thus, whilst a range of intermediate connecting members are required to be available to choose particular offsets and orientations, those intermediate connecting members are relatively cheap compared with the normally very high cost of the highly sophisticated head component.

Also, it is an advantage of the invention that the surgeon can choose quite independently of one another the three component parts. Thus, the surgeon does not have to be concerned with questions of offset and orientation when selecting the right head size. The same is true as regards the stem: the surgeon can choose the correct stem to fit the medullary canal in the humerus and so give a long lasting and secure joint between the stem and the bone. Having selected these components, the surgeon can, quite independently, decide on the particular offset and/or orientation of the head relative to the stem and select an intermediate connecting member accordingly. The surgeon is, therefore, able to match the modular prosthesis used to the original anatomy of a particular patient. Because a shoulder joint is enclosed and surrounded by soft tissue, it is desirable that the spacing between the end of the stem and the head be kept to a minimum, e.g. no greater than 5mm.

The typical surgical procedure for the implantation of a humeral prosthesis includes the determination of the longitudinal axis of the humerus, drilling a hole in the proximal margin between the head and the tuberosity in line with this, then inserting a starter reamer or broach, and developing a bore hole along the longitudinal axis of the humerus. Next, this bore hole can be enlarged by using progressively larger reamers or broaches, until the surgeon determines that the reamer or broach being used is the largest possible fit into the available cavity without the excessive removal of cortical bone. Then, the head is accurately removed from the proximal portion of the humerus, and a flat angled face is prepared on the proximal portion of the humerus, usually along the line of the anatomical neck, by means of a resection guide.

The cavity thus prepared, the trial stem can be introduced. At this stage, the surgeon is able to determine the amount of anteversion that is appropriate for the patient. Once in place, the head measurement instrument can be attached, and the trial head attached to this. This head measurement instrument allows the accurate placement of the head in a number of different positions so that the surgeon to assess which position best suits the exact anatomy of the patient. Once determined, the surgeon can read off the specific orientation of the head from a number of scales on the instrument; this determines which intermediate connecting member is to be used with the definitive implant.

It is not possible to provide an infinite number of intermediate connecting members so as to cover every possibility of adjustment. In practical terms, therefore, one provides a range of intermediate connecting members in incremental sizes to provide a range of discrete adjustments in just the same way that a discrete number of heads and stems are provided. However, because the engagement means allows the relative rotation of the components, one can with a single intermediate connecting member choose an amount of offset and that amount can be positioned on a locus throughout 360°. The same, of course, is true as regards the inclination of the axis of the head relative to the stem.

In a preferred embodiment of the invention, the intermediate connecting member is available in a discrete number of sizes, each size providing an incremental increase in the separation between the two engagement means. Thus, the surgeon is provided with a variety of parts from which to choose in order to best approximate the patient's original anatomy by selecting a part that will provide the closest approximation of the original separation between the humeral head and the humeral stem.

It is preferred that each engagement means comprise a male projection on one part that fits within a complimentary female recess in the other. Preferably, at least the first engagement means, and in some embodiments of the invention the second engagement means as well, allows relative rotation of the respective parts. Therefore, they should be of circular cross-section.

It is further preferred that the second engagement means locate at the center of the base of the humeral head. Thus, in this preferred embodiment, the

relative rotational placement of the head component has no effect in altering the angle of inclination of the head or the axial offset of the head in relation to the stem or even the separation between the head and the stem. Indeed it is not essential that the second engagement means be of circular cross-section although this is preferred. This has the advantage that fewer of the expensive head components are required to achieve this range of variables. Naturally the head will have to be provided in a number of incrementally varying sizes to fit the needs of each individual patient's scapula or glenoid prosthesis.

The portion of the engagement means forming part of the intermediate connecting member can both be male or alternatively one can be male and the other female.

It is further desired that the engagement means will each be of a substantially cylindrical shape, whether male or female, and therefore allow the intermediate connecting member to be rotatable relative to the stem and the head rotatable relative to the intermediate connecting member before securement. To fix one part relative to the other the cylinders of the male and female portions are preferably of the Morse taper type. This fixing may be supplemented by a screw fixing.

In order to satisfy the criterion for strength, it is desirable that the intermediate connecting member be formed in one piece. It is, however, within the scope of this invention that the intermediate connecting member be formed from a plurality of pieces.

Brief Description of the Drawing

Embodiments of the invention will now be described by way of example only and with reference to the accompanying schematic drawings, in which:

Figure 1 is an exploded side elevation of a modular humeral prosthesis according to the invention;

Figure 2 is the assembled prosthesis of Figure 1;

Figures 3 to 7 are various intermediate connecting members according to the first embodiment of the invention;



Figure 8 is an exploded side elevation of a second embodiment of the modular humeral prosthesis according to the invention; and

Figures 9-13 are various intermediate connecting members according to the second embodiment of the invention.

5

Detailed Description of Preferred Embodiments

The stem 10 shown in Figure 1 is available in a number of different sizes to match the size to which the medullary canal 12 has been reamed or broached. The shaft 14 of the stem is designed to contact the previously reamed or broached medullary canal 12 and extend into the remaining humerus to prevent any movement of the stem 10.

10

15

20

25

The stem 10 is prevented from rotating by the use of fins 16 located at the neck of the stem 10. These fins 16 are wedged into the proximal position of the humerus to prevent any movement of the stem 10 and offer some additional support to the face 18 of the stem 10. The face 18 of the stem 10 fits onto the previously prepared face of the humerus 20, and is designed so that the angle of the face 18 is roughly equal to that of the anatomic neck of the humerus. PCT International patent application No. US97/18207, filed October 8, 1997, both by Michel Mansat et al., disclose a shoulder prosthesis with fins.

The humeral head 22 is designed to articulate with the scapula or glenoid prosthesis (not shown). The head 22 replaces the articulating surface of the humerus and is largely hemispherical in shape. A variety of sizes of head 22 are provided to complement the patient's scapula on glenoid prosthesis. The articulating surface of the head 22 is highly polished to reduce friction, hence wear on the scapula or glenoid prosthesis.

An intermediate connecting member 24 has first and second male tapers 26 and 28 of the "Morse taper" type. A "Morse taper" is taper that forms an angle providing a self-locking function. Once pushed together two Morse taper parts tend to stay together. The first taper 26 is designed to connect with the stem 10 and the second taper 28 with the head 22. The tapers 26 and 28 are aligned in generally opposite directions for mating with a female taper 30 of the stem 10 and a female taper 32 of the head 22.

30



The first male taper 26 may also be held onto the female taper 30 of the stem 10 by means of a locking screw 34, which fits into a counter-bored hole 36 in the intermediate connecting member 24. The axis of this counter-bored hole 36 is aligned along the central axis of the taper 26 and the screw fits into this counter-bored hole 36 and locates into a threaded hole 38 in the stem 10.

The male tapers 26, 28 of the intermediate connecting member 24 are securely connected with the respective female tapers 30, 32 of the stem 10 and head 22, which are also of the Morse taper type and match the tapers of the intermediate connecting member 24 by applying an external force, to form an interference fit between the mating tapers 24 and 30, and 26 and 32, as shown in Figure 2.

It will be understood that the first and second male tapers 26 and 28 constitute one embodiment of the first and second engagement means of the intermediate connecting member 24. Alternatives include other connecting or mating parts that define the relative orientation and position of the head 22 and the intermediate connecting member 24 or the stem 10 and the intermediate connecting member 24. For example, the first and second male tapers 26 and 28 could be replaced by female tapers (not shown) and the female tapers 30 and 32 of the stem 10 and head 22 replaced by male tapers (not shown).

There can be a large variety in the shape, size and orientation of human humeral bones and therefore it is desirable to tailor the humeral prosthesis to suit each individual case. The various designs of intermediate connecting members of the present invention provide a massive range of different head positions and orientations relative to the humeral stem that can be selected and connected inter-operatively.

The position of the head 22 can be varied by using different intermediate connecting members 24 as are appropriate in each individual case. Various designs of intermediate connecting members 24a-e are illustrated in Figures 3 to 7.

In each of these cases the intermediate connecting member 24a-e has the same elements and is joined to the stem 10 and head 22 as described above.

One configuration of an intermediate connecting member 24a is illustrated in Figure 3. In this configuration, the first male taper 40 and the second male taper 42 are axially aligned with minimum separation or "neck length" 44 between them. The design of this intermediate connecting member 24a matches the anatomical design of some patients' original humerus.

For other patients, a larger separation between the head 22 of the humeral prosthesis and a fixed point on the stem 10 is more appropriate. To meet this requirement, the intermediate connecting member 24b of Figure 4 is used. In this design, a portion of the intermediate connecting member 24b between the two tapers 50 and 52 is available in a number of incrementally different sizes to allow the surgeon to select the appropriate separation or "neck length" 54 between the tapers 50 and 52, and hence the separation between the head 22 and stem 10 of the prosthesis.

The anterior or posterior offset can be simulated using the design of intermediate connecting member 24c as shown in Figure 5 to mimic offsets 66 that can naturally occur in the humerus. In this design, the central axes of the first and second male tapers 60 and 62 are parallel and offset from one another as illustrated at 66. The second male taper 62 is counter-bored at an off-center position (e.g., compare bore 68 or figure 5 with bores 48 and 58 of figures 3 and 4). This allows the head 22 to be attached on a parallel but not coincident axis to the first male taper 60, and thus to the female taper 30 of the stem 10. Again, this design is available in a number of incrementally different offsets 66 so the surgeon can select the most appropriate intermediate connecting member 24c for each individual patient inter-operatively.

The angle of inclination α of the humeral head relative to the axis of the humeral stem can vary from patient to patient. The intermediate connecting member 24d can simulate this orientation. The design shown in figure 6 comprises a portion of the intermediate connecting member 24d that has a generally wedge-shaped design. The surgeon will be able to select the wedge-shaped intermediate connecting member 24d from a range of intermediate connecting members 24d having incremental difference in the inclination angle α as shown in Figure 6, to best fit each individual patient. Due to the wedge-shape, the central axes of the first

and second male tapers 70 and 72 of this design are offset from parallel by an angle equal to the inclination angle α .

Any of the features of intermediate connecting members 24a-d illustrated in figures 3 to 6 can be combined to provide the desired variation in neck length 44, 54, 84 anterior or posterior offset 66, 86 or angular inclination α to best suit each individual patient's anatomy.

Figure 7 shows an intermediate connecting member 24e that includes a combination of the angular inclination α as described in figure 6, the anterior/posterior offset 86 as depicted in figure 5, and the taper separation 84 as illustrated in Figure 4.

In the above embodiments, the male members of the two engagement portions are provided by the intermediate connecting member 24a-e. In an alternative embodiment one or both of the two engagement portions provided by the intermediate connecting member may comprise female portions. For example, figure 8 illustrates a second embodiment of the modular humeral prosthesis 100 of the invention similar in many respects to the first embodiment shown in figures 1-7. Differences include the provision of a male tapered connecting portion 102 on the stem 104, and a female tapered connecting portion 106 on the intermediate connecting member 108.

Male connecting portion 102 and female connecting portion 106 are designed for substantially self-locking mating, and preferably have a circular cross section. The self-locking function may be accomplished by providing a "Morse taper" on the male and female connecting portions 102 and 106. The female connecting portion 106 constitutes a second embodiment of the first engagement portion of the intermediate connecting member 108.

A fastener 110 preferably is inserted through a bore 112 through the intermediate connecting member 108 and into engagement with a bore 114 in the stem 104 to further secure the female connecting portion 106 of the intermediate connecting member 108 on the stem 104. Most preferably, the fastener 110 and the bore 114 are provided with interlocking threads. As an alternative embodiment, the male and female connecting portion 102 and 106 could be



provided with a non-self-locking configuration; in which case the fastener 110 or another locking mechanism would take on yet greater importance.

As is the case with the first embodiment, the head 114 of the second embodiment is provided with a female connecting portion 116, and the second engagement means of the intermediate connecting member 108 comprises a male connecting portion 118. The female and male connecting portions 116 and 118 are also preferably provided with a self-locking tapered configuration, i.e., a Morse taper.

Figures 9-13 illustrate various intermediate connecting members 108a-e for use in the prosthesis 100. Figures 9 and 10 illustrate two intermediate connecting members 108a and 108b providing two different separations 120 and 122. In this respect, intermediate connecting member 108a is similar to intermediate connecting member 24a of the first embodiment (figure 3) due to the minimal separation 120 or 44, and intermediate connecting member 108b is similar to intermediate connecting member 24b of the first embodiment (figure 4) due to the greater separation 122 or 54. Both intermediate connecting member 108a and 108b show a zero inclination angle and a zero offset.

Figure 11 illustrates another intermediate connecting member 108c having, like member 108a, minimal separation. Intermediate connecting member 108c, however, has a non-zero offset 124. This non-zero offset 124 is accomplished by displacing or offsetting the central axis or axis of rotation of the female locking portion 126 relative to the central axis of axis of rotation of the male locking portion 128 by the offset 124. In this respect, the intermediate connecting member 108c is similar to the intermediate connecting member 24c of the first embodiment (figure 5).

Figure 12 illustrates yet another intermediate connecting member 108d having, like member 108a, minimal separation and zero offset. Intermediate connecting member 108d, however, has a non-zero inclination angle β . Inclination angle β is similar in function and preferred magnitude to the inclination angle α discussed with respect to the first embodiment (e.g., figure 6).

Figure 13 illustrates an intermediate connecting member 108e having a non-zero separation 130, a non-zero offset 132 and a non-zero inclination

angle β . In this respect, intermediate connecting member 108e is similar to intermediate connecting member 24e of the first embodiment (figure 7).

One consequence of the design of the second embodiment of the prosthesis is that the male connecting portion 118 may have a length extending into the intermediate connecting member, e.g., 108a, a distance sufficient that it is received both in the intermediate connecting member 108a and the void defined by the female connecting portion 116 of the head 114. This is accomplished, of course, without any direct engagement between the male connecting portion 118 of the stem 104 and the female connecting portion 116 of the head 114.

Other embodiments, which are not illustrated in the drawing, include (1) the first engagement means comprising a male connecting portion and the second engagement means comprising a female connecting portion, and (2) both the first and second engagement means comprising female portions.

As various changes could be made in the above constructions and methods without departing from the scope of the invention as defined in the claims, it is intended that all matter contained in the above description or shown in the accompanying drawings be interpreted as illustrative and not in a limiting sense.

Throughout this specification and the claims which follow, unless the context requires otherwise, the word "comprise", and variations such as "comprises" and "comprising", will be understood to imply the inclusion of a stated integer or step or group of integers or steps but not the exclusion of any other integer or step or group of integers or steps.

The reference to any prior art in this specification is not, and should not be taken as, an acknowledgment or any form of suggestion that that prior art forms part of the common general knowledge in Australia.

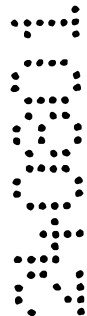
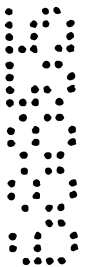

THE CLAIMS DEFINING THE INVENTION ARE AS FOLLOWS:

1. A modular humeral prosthesis for replacement of the humeral head of a humerus, comprising:

5 a stem adapted to be fitted to a resected humerus, the stem having a proximal face which in use is adapted to extend generally parallel with the resected surface of the humerus and the stem including a first mating portion for engaging with an intermediate connecting member;

10 a head sized and configured to approximate the humeral head, the head including a second mating portion for engaging with an intermediate connecting member; and

an intermediate connecting member for connecting the stem to the head, the intermediate connecting member including:

15 a first engagement portion for mating engagement with the first mating portion to mount the intermediate connecting member on the stem, the intermediate connecting member being rotatable through 360° relative to the stem about the first mating portion and being securable at a selected relative orientation; and

20 a second engagement portion for mating engagement with the second mating portion to mount the head on the intermediate connecting member, the head being rotatable through 360° relative to the intermediate connecting member about the second engagement portion and being securable at a selected relative rotation;

25 wherein the axes of rotation of the first and second engagement portions are not coincident and wherein the arrangement of the stem, the head and the intermediate connecting member is such that a desired offset of the head relative to the stem can be achieved by rotating one or both of the head and the intermediate connecting member through any angle up to 360° relative to the intermediate connecting member and to the stem, respectively.

30



2. The modular humeral prosthesis according to claim 1 wherein the first mating portion has an axis which is perpendicular to the proximal face of the stem.

3. The modular humeral prosthesis according to claim 1 or 2 further comprising a threaded fastener for securing the intermediate connecting member, the threaded fastener being substantially aligned with the axis of the first engagement portion.

4. The modular humeral prosthesis according to claim 3 in which a bore through the first and second engagement portions extends through the intermediate connecting member, the fastener being insertable through the bore to engage the stem.

5. The modular humeral prosthesis according to any one of claims 1 to 4 in which the axes of rotation of the first and second engagement portions are not parallel, whereby the engagement means allow a desired inclination of the head relative to the stem.

6. The modular humeral prosthesis according to any one of the preceding claims wherein the intermediate connecting member does not project beyond the proximal face of the stem.

7. The modular humeral prosthesis according to claim 6 wherein the intermediate connecting member is substantially completely enclosed between the head and the stem.

8. The modular humeral prosthesis according to any one of the preceding claims in which the separation between the head and the stem is no greater than 5mm.

9. The modular humeral prosthesis according to any one of the preceding claims wherein both the first and the second engagement portions are female.

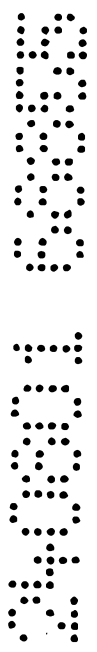

10. The modular humeral prosthesis according to any one of claims 1 to 8 wherein one of the first and second engagement portions is female, and the other of the first and the second engagement portions is male.

5

11. The modular humeral prosthesis according to any one of claims 1 to 8 wherein both the first and the second engagement portions are male.

12. The modular humeral prosthesis according to claim 11 wherein the first and second male engagement portions have a substantially self-locked tapered configuration.

13. The modular humeral prosthesis according to claim 11 or 12 wherein the first and second male engagement portions have a substantially circular cross-section.

14. A modular humeral prosthesis substantially as herein described with reference to the accompanying drawings.

15. A modular humeral prosthesis kit for replacement of the humeral head of a humerus, comprising:

a stem adapted to be fitted to a resected humerus, the stem having a proximal face which in use is adapted to extend generally parallel with the resected surface of the humerus and the stem including a first mating portion for engaging with an intermediate connecting member;

a head sized and configured to approximate the humeral head, the head including a second mating portion for engaging with an intermediate connecting member; and

a plurality of intermediate connecting members of which one may be selected to connect the stem to the head, each intermediate connecting member including:

a first engagement portion for mating engagement with the first mating

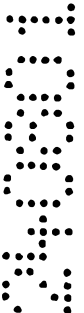
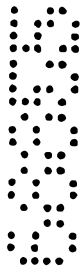

portion to mount the intermediate connecting member on the stem, the intermediate connecting member being rotatable through 360° relative to the stem about the first mating portion and being securable at a selected relative orientation; and

5 second engagement portion for mating engagement with the second mating portion to mount the head on the intermediate connecting member, the head being rotatable through 360° relative to the intermediate connecting member about the second engagement portion and being securable at a selected relative rotation;

10 the intermediate connecting members of the kit including:

at least one intermediate connecting member in which the first and second engagement portions have generally parallel and coincident axes;

at least one intermediate connecting member in which the first and second engagement portions have generally parallel but not coincident axes;

15 at least one intermediate connecting member in which the first and second engagement portions have an angle (α) of inclination between one another that is different to the angle of inclination between the first and second engagement portions of another intermediate connecting member of the kit; and

20 at least one intermediate connecting member in which the first and second engagement portions are separated by a different neck length, than the neck length separating the first and second engagement portions of another intermediate connecting member of the kit;

and wherein the arrangement of the stem, the head and the intermediate connecting member is such that a desired orientation of the head relative to the stem can
25 be achieved by rotating one or both of the head and the intermediate connecting member through any angle up to 360° relative to the intermediate connecting member and to the stem, respectively.

30 16. The kit according to claim 15 wherein the first mating portion has an axis which is perpendicular to the proximal face of the stem.



17. The kit according to claim 15 or 16 in which each intermediate connecting member is provided with a bore therethrough which extends through the first and second engagement portions, the kit further comprising a fastener insertable through
5 the bore to engage the stem to further secure the intermediate connecting member to the stem, the bore being substantially aligned with the axis of the first engagement portion.

18. The kit according to any one of claims 15 to 17 wherein the selected intermediate connecting member does not project beyond the proximal face of
10 the stem.

19. The kit according to claim 18 wherein the selected intermediate connecting member is substantially completely enclosed between the head and the stem.

20. The kit according to any one of claims 15 to 19 in which the separation between the head and the stem is no greater than 5mm.

21. The kit according to any one of claims 15 to 20 wherein both the first and the second engagement portions of each intermediate connecting member are
20 female.

22. The kit according to any one of claims 15 to 20 wherein, for each intermediate connecting member, one of the first and second engagement portions is female, and the other of the first and the second engagement portions is male.
25

23. The kit according to any one of claims 15 to 20 wherein both the first and the second engagement portions of each intermediate connecting members are male.

24. The kit according to claim 23 in which the first and second male engagement portions have a substantially self-locking tapered configuration.
30



25. The kit according to claim 23 or 24 wherein the first and second male engagement portions have a substantially circular cross-section.

5 26. A modular humeral prosthesis kit substantially as herein described with reference to the accompanying drawings.

DATED this 22nd day of August 2001

10 **Smith & Nephew, Inc.**

by DAVIES COLLISON CAVE
Patent Attorneys for the Applicants

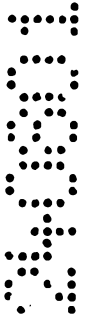
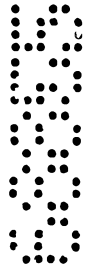

14-15



1/4

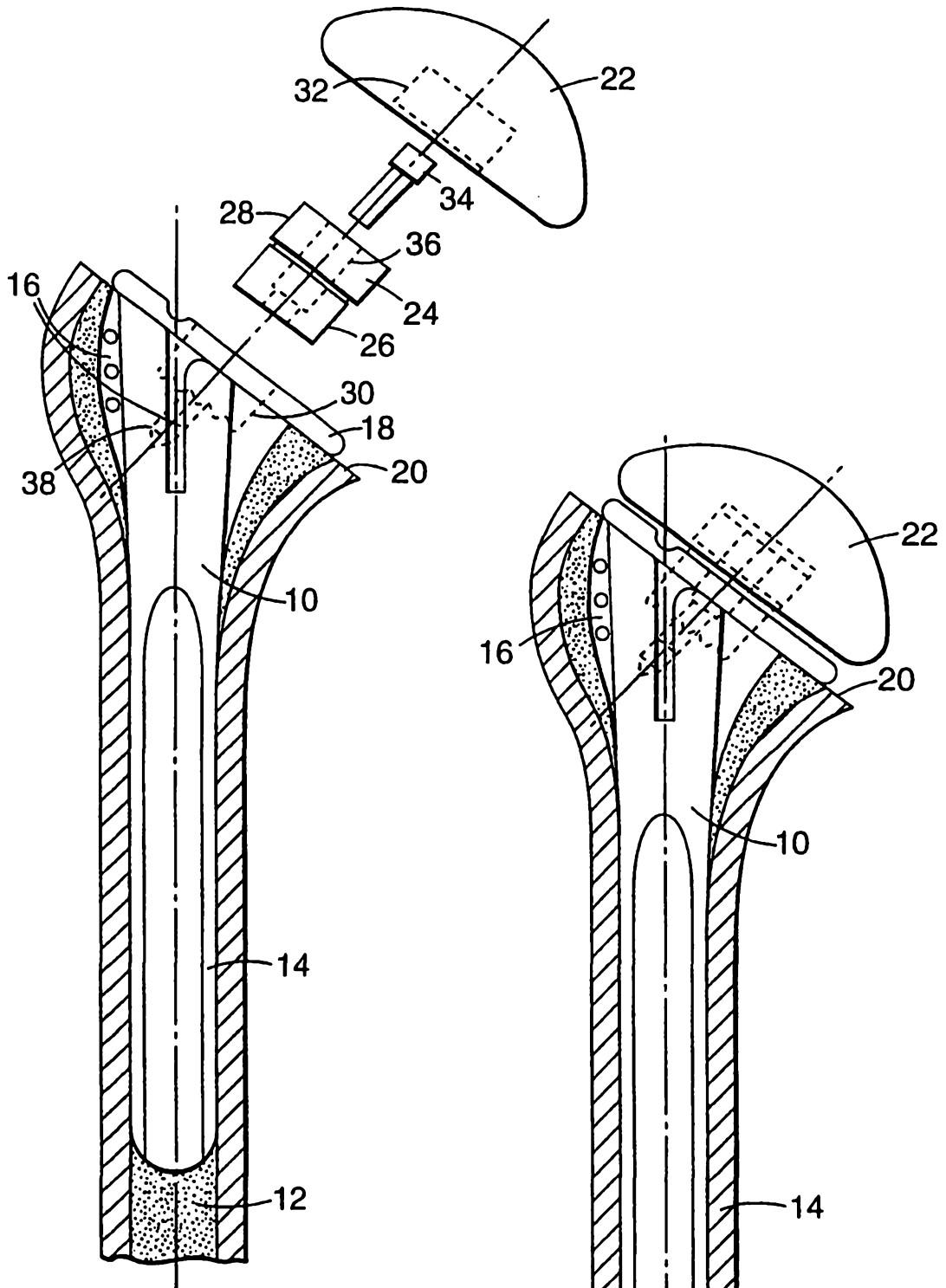

Fig. 1

Fig. 2

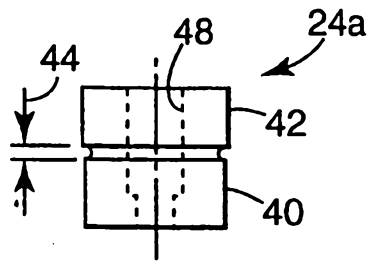

Fig. 3

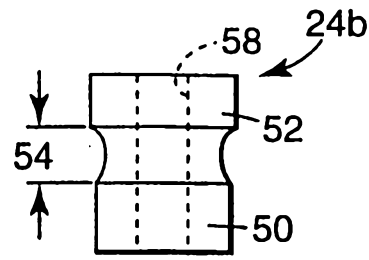

Fig. 4

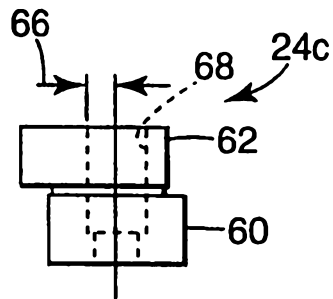

Fig. 5

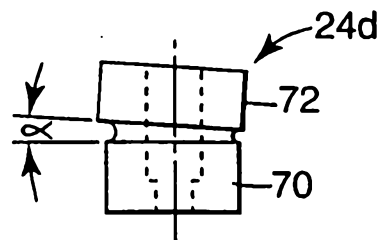

Fig. 6

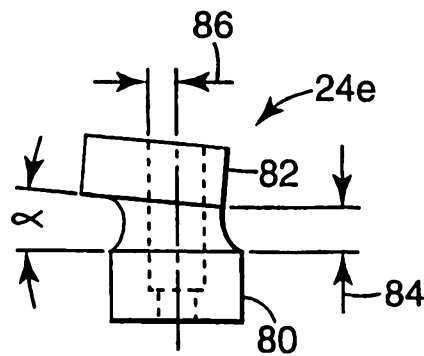

Fig. 7

3/4

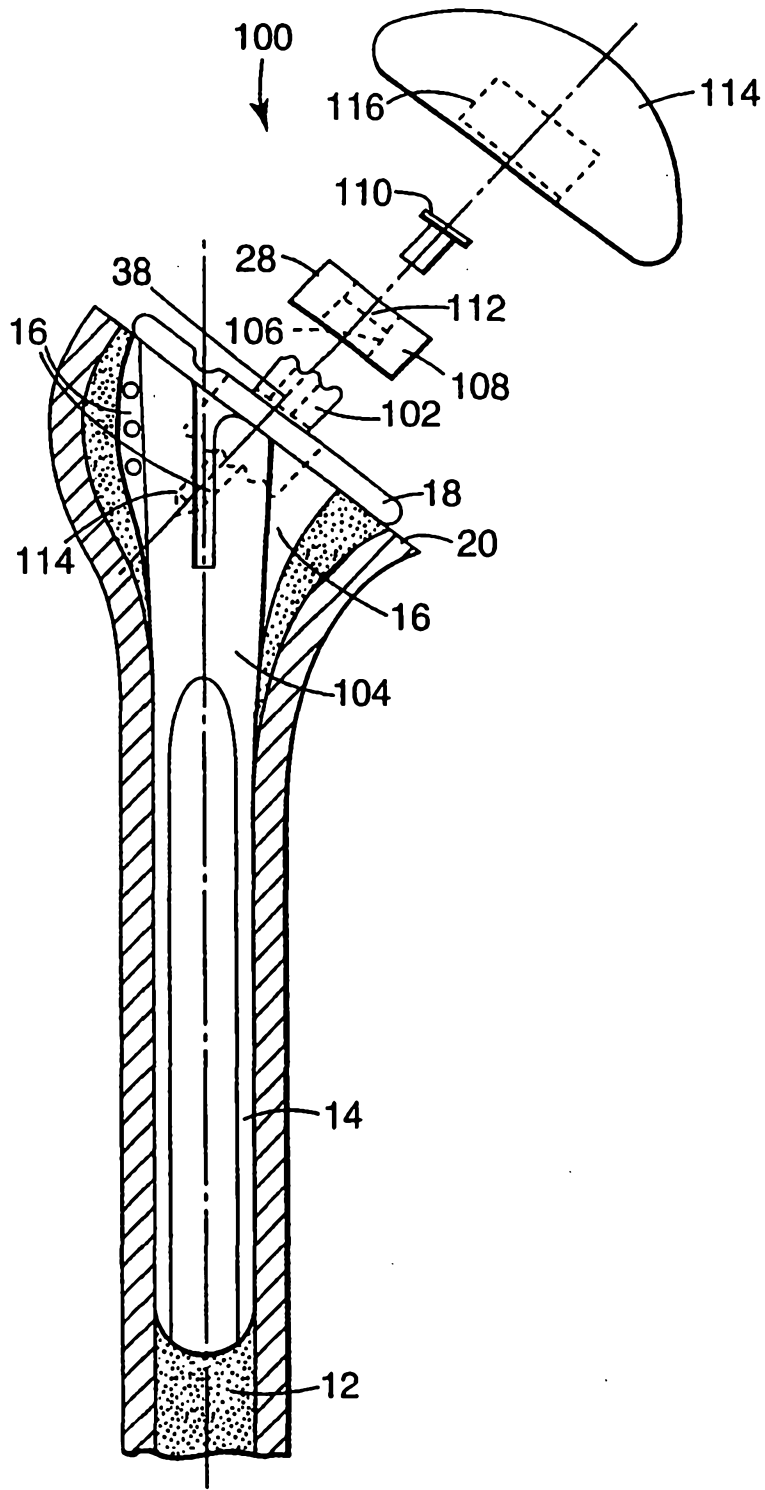

Fig. 8

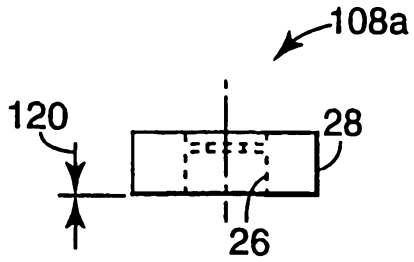

Fig. 9

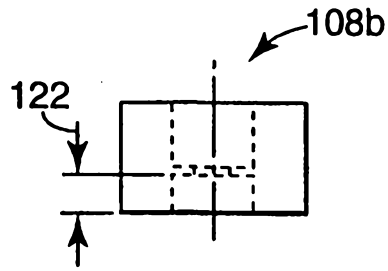

Fig. 10

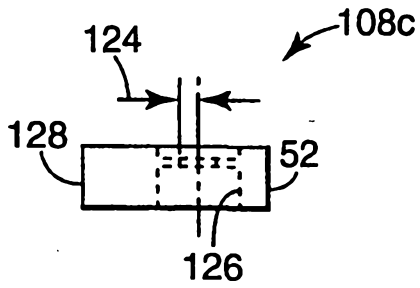

Fig. 11

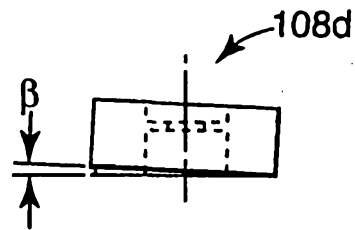

Fig. 12

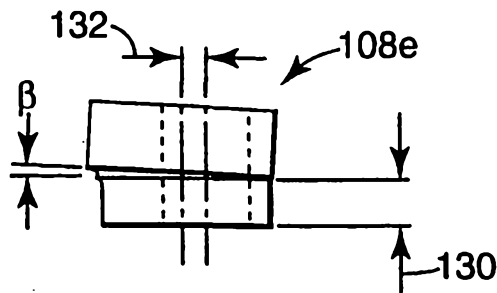

Fig. 13