

July 5, 1932.

H. DAHLMAN ET AL

1,865,618

BRIDGE SET ACCESSORY

Filed Dec. 15, 1931

2 Sheets-Sheet 1

Fig. 1

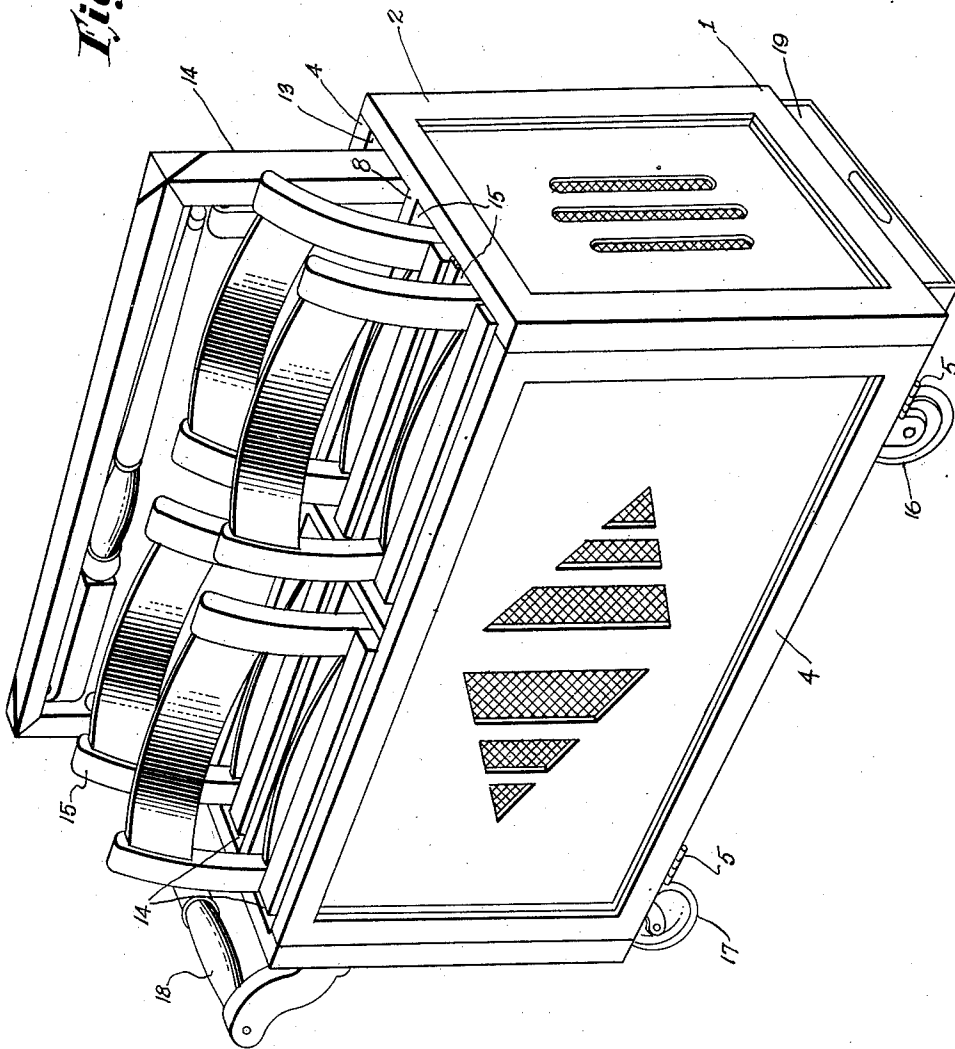

INVENTOR.
Dudley Dahlman
Helen Dahlman
BY
Frankis Fabris
ATTORNEY.

July 5, 1932.

H. DAHLMAN ET AL

1,865,618

BRIDGE SET ACCESSORY

Filed Dec. 15, 1931

2 Sheets-Sheet 2

Fig. 2

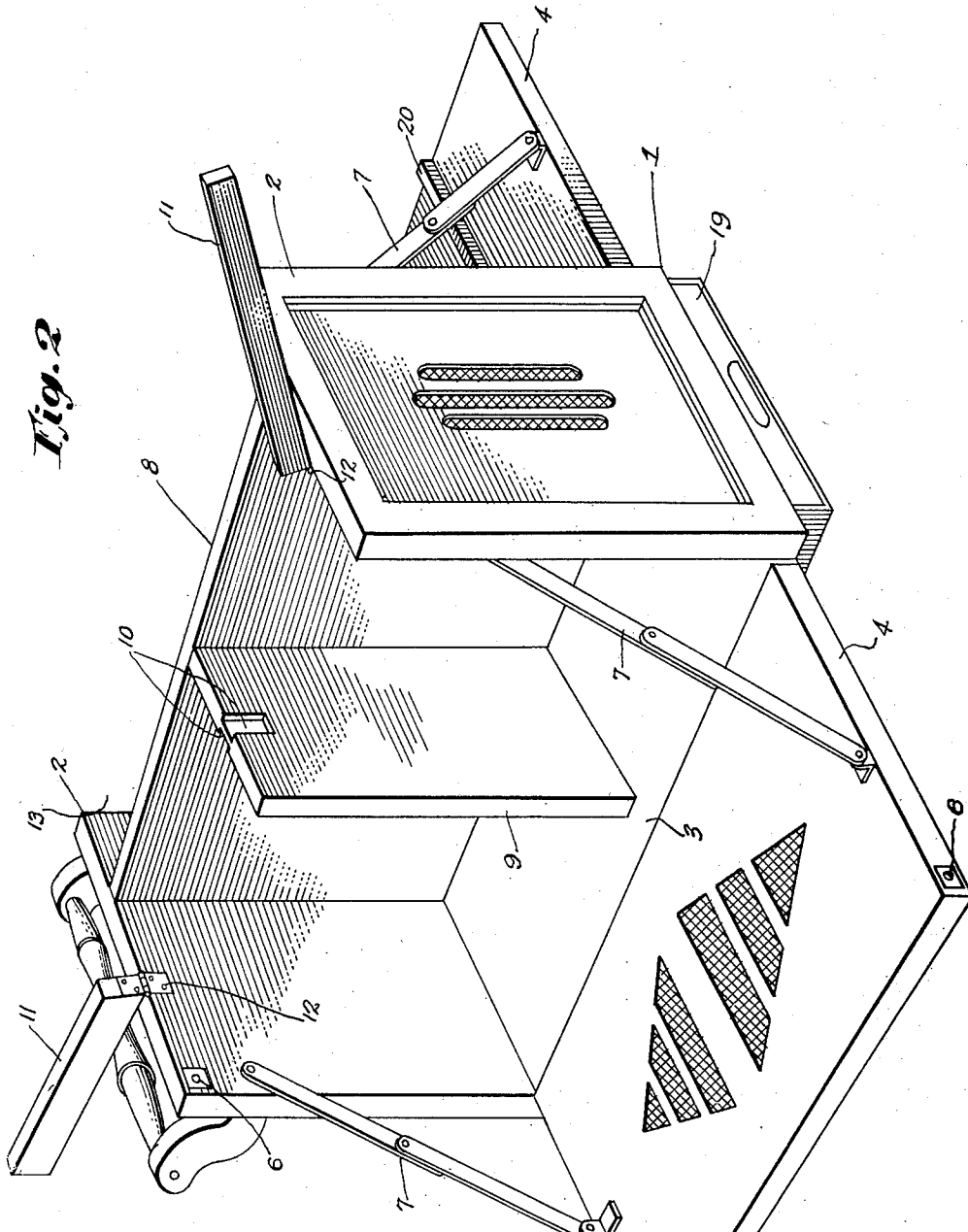

INVENTOR.
Dudley Dahlman
Helen Dahlman
BY
Stanislaw Zaluski
ATTORNEY.

UNITED STATES PATENT OFFICE

HELEN DAHLMAN AND DUDLEY DAHLMAN, OF BROOKLYN, NEW YORK

BRIDGE SET ACCESSORY

Application filed December 15, 1931. Serial No. 581,193.

This invention is an accessory to a bridge set which, as is well known, usually comprises a folding table and four folding chairs.

The accessory of the present invention, generally speaking, consists of a carriage or receptacle in which a bridge set may, when not in use, be supported and contained in such manner as to provide a convenient storage space for the bridge set and at the same time to permit the same to be readily moved about a house or an apartment.

It has heretofore been the practice to store bridge sets, when not in use, loosely within closets or other convenient storage spaces and when it has been desired to use the set, it has been brought forth one piece at a time and unfolded and set up. Not infrequently, the chairs and table of such a set are heavy and unwieldy and may be of expensive construction with high quality finishes so that handling, in the manner specified, is not only an arduous task, particularly for the ladies, but generally results in scratching of the finishes or damage to the parts.

According to the present invention, in contradistinction, an accessory is provided which, when the tables and chairs of a set are not in use, these parts may be conveniently and compactly received in folded condition. The said accessory is in the form of a receptacle mounted upon appropriate wheels and having the appearance of a piece of furniture, so that when the tables and chairs are contained therein, it is entirely feasible to leave the device in full view although if desired said device may be readily rolled into a closet or elsewhere out of sight.

The accessory of this invention embodies numerous novel features which will hereinafter be more fully described and set out in the appended claims.

The accompanying drawings illustrate one practical embodiment of the invention, but the construction shown therein is to be understood as illustrative, only, and not as defining the limits of the invention.

Figure 1 is a perspective view showing the accessory of the present invention in its normal folded condition housing and supporting the bridge set.

Figure 2 shows the accessory in unfolded condition with the bridge set removed.

Referring to the drawings, 1 designates the body of a receptacle, the same comprising upstanding ends 2 which in the form of the invention shown are rigid with the bottom 3. To the opposite sides of the receptacle are pivoted drop leaves 4 which constitute the side walls. These drop leaves are secured to the bottom by appropriate hinges 5 and are normally held in upstanding or closed position by suitable catches such, for example, as the male and female snap catches 6 shown in Figure 2. Collapsible brackets 7 are associated with the side walls 4, so that when these walls or leaves are lowered, they are supported by these brackets in substantially horizontal positions. The interior of the receptacle is divided by partitions into a plurality of compartments. Of these partitions, the longitudinal partition 8 extends from end to end of the receptacle in spaced relation to both side walls and somewhat nearer to one of them than to the other. This partition 3 is rigid with respect to the end walls 2 and serves to impart rigidity to the body.

A transverse partition 9 extends from substantially the medial portion of the partition 8 toward one of the sides 4 and is preferably notched near its upper edge as indicated at 10 to receive movable or hinged partition sections 11 which are secured by hinges 12 to the end walls 2 and are adapted to be folded downwardly to engage with the notches 10. When the partition sections 11 are infolded as suggested and the side walls or leaves 4 are in their closed positions, the interior of the receptacle is divided by the partitions described into five compartments. One of these compartments designated 13 forms an elongated narrow space of such size and dimensions as to conveniently receive in fairly close fitting relation a folded card table 14. Each of the other compartments 15, all of which are of the same size are of such dimensions as to individually receive folded or collapsed chairs 15, so each compartment may receive one element of a five piece bridge set in such manner that the elements are individually housed in spaced relation to one

another so that they will not contact with one another and be scratched or marked by such contact. If desired, the several compartments of the receptacle may be lined with
 5 felt, plush or other soft and non-abrasive material, so as to cushion the elements of the set, save the finishes from injury and preclude rattling.

In order to facilitate the movement of the
 10 accessory from place to place as from one room to another or from one room into a closet, or vice versa, there is secured to the under side of the bottom a plurality of wheels 16 and 17. The wheels 16 are preferably mounted upon
 15 rigid hangers attached to the under side of the bottom. The wheels 17 of which there may be one or two are preferably mounted with swivel hangers so as to facilitate change
 20 in direction of movement of the receptacle as it is rolled along the floor. The handle 18 which in practice may be of any appropriate form and one of which may be applied to each
 25 end of the receptacle may be conveniently provided.

To provide satisfactory storage space for cards, chips and other game accessories, we preferably provide the device with one or
 30 more drawers 19, which, as shown in the drawings, may be conveniently mounted beneath one end of the bottom.

In practice, the receptacle is made to appear as an article of furniture. It may be
 35 constructed or fabricated from wood, metal, or other appropriate materials and is preferably made more or less ornamental to suit individual tastes or to fit into decorative schemes of the home in which it is intended
 40 for use.

Under ordinary conditions, when the set is not in use, the chairs and table are packed and contained within the several compartments of the receptacle, after the manner
 45 shown in Figure 1 and when thus housed, the receptacle may be moved from place to place to transport the set as a unit in a convenient manner and in a way that requires neither strength nor a number of trips to move the
 50 set.

When the set is to be used, the adjunct is moved into convenient position and the side walls 4 are lowered. This permits the table to be shifted laterally out of this compartment and set up. Thereafter the two
 55 chairs nearest the other side 4 may be removed and unfolded, whereupon the partition sections 11 may be swung upwardly out of the way and the other two chairs removed and placed in position. The sides of the device may thereupon be folded up into
 60 normal position, the partition sections 11 infolded and the receptacle moved out of the way until the set is to be again collapsed and stored away as will be clearly understood.

65 The foregoing detailed description sets

forth the invention in one practical form which we have found to be convenient and economical. We are aware, however, that the invention may partake of different practical
 70 forms. For example, instead of making the sides fold down as shown, these sides may be made rigid with the bottom and the ends may fold down. In like manner, other changes or modifications may be availed of
 75 without departing from this invention, the scope of which is to be understood as fully commensurate with the appended claims.

Moreover, we have described this invention as a bridge set accessory. This is the
 80 primary purpose for which the invention was conceived. It will be understood, however, that inasmuch as the device carries a card table and chairs that the elements of such set may be used in connection with other
 85 games than bridge. Similarly, it will be understood that if desired, the device may be made bigger than as shown in the drawings and of sufficient size to carry a plurality of bridge sets. These changes and others of
 90 similar import are within the purview of this invention.

It will be noted that one of the sides 4 is provided on its upper surface with tracks 20
 95 of which there may be two or more so as to facilitate the sliding of the table over the side when the latter is lowered. Similar tracks may be provided on the other side to allow the chairs to be slid into and out of the
 100 respective compartments.

Having thus fully described the invention, what we claim and desire to secure by Letters Patent is:

1. A bridge set accessory embodying a receptacle having four upstanding exterior
 105 walls and an open top, rigid partitions dividing the interior of the receptacle into a plurality of compartments and hinged partition members dividing certain of said compartments into smaller compartments to thereby divide the interior of the receptacle
 110 into a plurality of compartments of such shape and dimension as to individually contain the different parts of a bridge set, two of the upstanding exterior walls of said receptacle being hinged whereby, when said exterior walls are in opened position and the hinged partitions also in opened position, the parts of the bridge set may be conveniently
 115 positioned within or removed laterally from the receptacle.

2. A bridge set accessory embodying a wheeled receptacle having a bottom and upstanding exterior walls, some of which walls are hinged with respect to the bottom, so
 120 that they may be opened to permit parts of a bridge set to be positioned in or removed laterally from the receptacle, and longitudinal and transverse partitions within the interior of the receptacle, some of which partitions are rigid and others of which are
 125
 130

hinged to divide the interior of the receptacle into individual compartments for the individual parts of the bridge set and to permit of the removal of said parts through the sides of the receptacle when the hinged exterior walls are in opened position.

In testimony whereof, we have signed the foregoing specification.

HELEN DAHLMAN.
DUDLEY DAHLMAN.

6

10

15

20

25

30

35

40

45

50

55

60

65