



(86) Date de dépôt PCT/PCT Filing Date: 2013/03/12
 (87) Date publication PCT/PCT Publication Date: 2013/09/19
 (85) Entrée phase nationale/National Entry: 2014/08/08
 (86) N° demande PCT/PCT Application No.: EP 2013/054963
 (87) N° publication PCT/PCT Publication No.: 2013/135669
 (30) Priorité/Priority: 2012/03/12 (EP12159116.8)

(51) Cl.Int./Int.Cl. *G01N 21/84* (2006.01)
 (71) Demandeur/Applicant:
 F. HOFFMANN-LA ROCHE AG, CH
 (72) Inventeurs/Inventors:
 LIMBURG, BERND, DE;
 RUECKERT, FRANK, DE;
 SCHMIDT, BERNHARD, DE
 (74) Agent: GOWLING LAFLEUR HENDERSON LLP

(54) Titre : SYSTEME D'ESSAI ET PROCEDE POUR LE CONTROLE DE L'ALIGNEMENT D'UNE BANDELETTE D'ESSAI

(54) Title: TEST SYSTEM AND METHOD FOR MONITORING THE ALIGNMENT OF A TEST STRIP

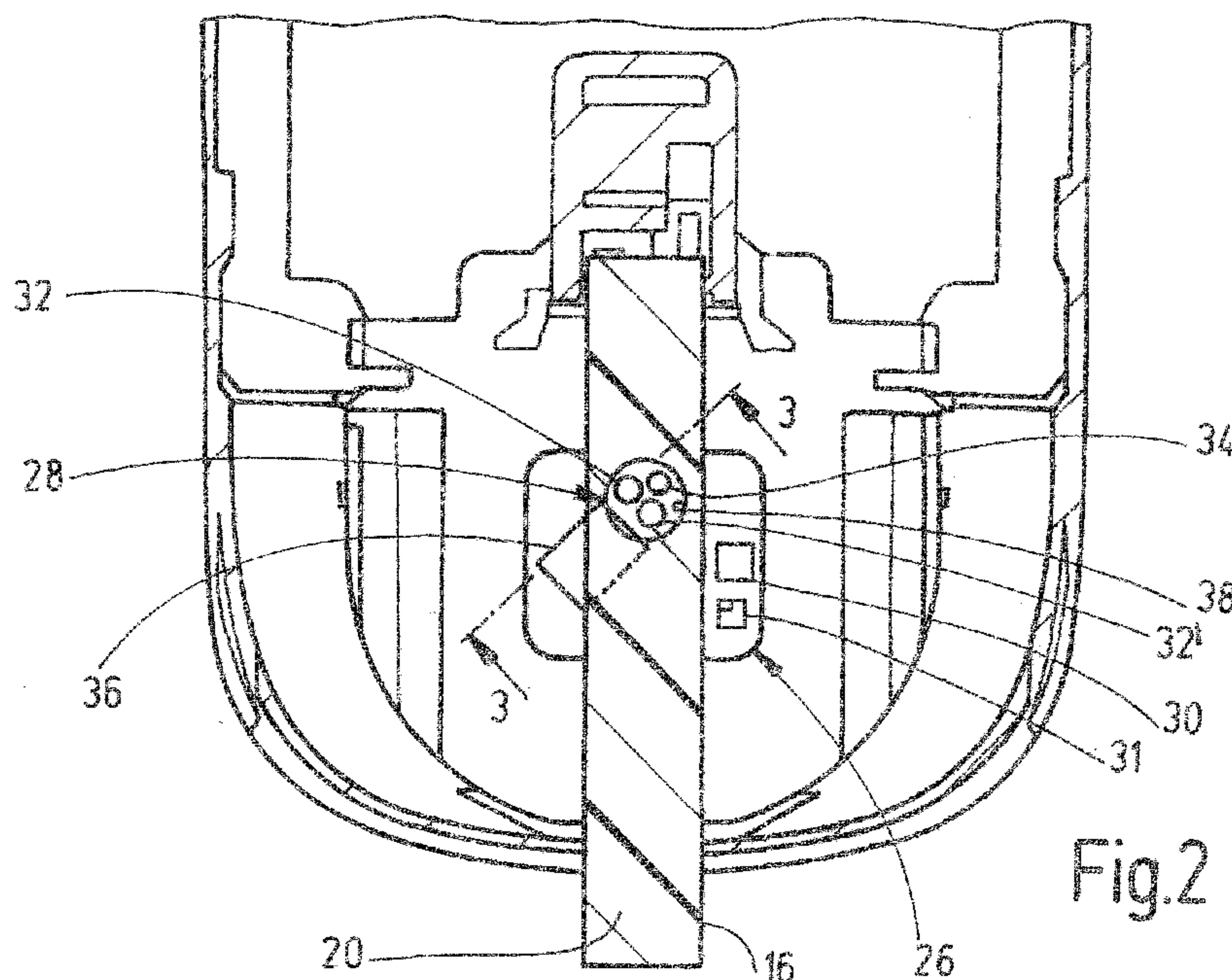

(57) **Abrégé/Abstract:**

The invention relates to a test system for analyzing a bodily fluid, in particular for determining the blood glucose level, comprising a test strip (16) which has an analytical test field (22), a photometric measuring unit (28) for detecting remission measurement values on the test field (22) which can be supplied with bodily fluid, a test strip support (14) for orienting the test strip (16) relative to the measuring unit (28), and a control unit (26) for controlling the test strip orientation. According to the invention, the measuring unit (28) detects at least one respective remission measurement value at different wavelengths, and the control unit (26) ascertains a correct or an incorrect test strip orientation by comparing the remission measurement values detected at the different wavelengths with specified reference values.

(12) NACH DEM VERTRAG ÜBER DIE INTERNATIONALE ZUSAMMENARBEIT AUF DEM GEBIET DES PATENTWESENS (PCT) VERÖFFENTLICHTE INTERNATIONALE ANMELDUNG

(19) Weltorganisation für geistiges

Eigentum

Internationales Büro

(43) Internationales
Veröffentlichungsdatum

19. September 2013 (19.09.2013)



(10) Internationale Veröffentlichungsnummer

WO 2013/135669 A1

- (51) Internationale Patentklassifikation:
G01N 21/84 (2006.01)
- (21) Internationales Aktenzeichen: PCT/EP2013/054963
- (22) Internationales Anmeldedatum:
12. März 2013 (12.03.2013)
- (25) Einreichungssprache: Deutsch
- (26) Veröffentlichungssprache: Deutsch
- (30) Angaben zur Priorität:
12159116.8 12. März 2012 (12.03.2012) EP
- (71) Anmelder (nur für DE): **ROCHE DIAGNOSTICS GMBH** [DE/DE]; Sandhofer Strasse 116, 68305 Mannheim (DE).
- (71) Anmelder (für alle Bestimmungsstaaten mit Ausnahme von DE, US): **F. HOFFMANN-LA ROCHE AG** [CH/CH]; Grenzacherstrasse 124, CH-4070 Basel (CH).
- (72) Erfinder; und
- (71) Anmelder (nur für US): **LIMBURG, Bernd** [DE/DE]; Im Selztal 18a, 55270 Soergenloch (DE). **RUECKERT, Frank** [DE/DE]; Christoph-Kroewerath-Straße 25, 67071 Ludwigshafen (DE). **SCHMIDT, Bernhard** [DE/DE]; Am Weissenburger Weg 14, 76865 Insheim (DE).
- (74) Anwälte: **PFIZ, Thomas** et al.; Hauptmannsreute 93, 70193 Stuttgart (DE).
- (81) Bestimmungsstaaten (soweit nicht anders angegeben, für jede verfügbare nationale Schutzrechtsart): AE, AG, AL, AM, AO, AT, AU, AZ, BA, BB, BG, BH, BN, BR, BW, BY, BZ, CA, CH, CL, CN, CO, CR, CU, CZ, DE, DK, DM, DO, DZ, EC, EE, EG, ES, FI, GB, GD, GE, GH, GM, GT, HN, HR, HU, ID, IL, IN, IS, JP, KE, KG, KM, KN, KP, KR, KZ, LA, LC, LK, LR, LS, LT, LU, LY, MA, MD, ME, MG, MK, MN, MW, MX, MY, MZ, NA, NG, NI, NO, NZ, OM, PA, PE, PG, PH, PL, PT, QA, RO, RS, RU, RW, SC, SD, SE, SG, SK, SL, SM, ST, SV, SY, TH, TJ, TM, TN, TR, TT, TZ, UA, UG, US, UZ, VC, VN, ZA, ZM, ZW.
- (84) Bestimmungsstaaten (soweit nicht anders angegeben, für jede verfügbare regionale Schutzrechtsart): ARIPO (BW, GH, GM, KE, LR, LS, MW, MZ, NA, RW, SD, SL, SZ, TZ, UG, ZM, ZW), eurasisches (AM, AZ, BY, KG, KZ, RU, TJ, TM), europäisches (AL, AT, BE, BG, CH, CY, CZ, DE, DK, EE, ES, FI, FR, GB, GR, HR, HU, IE, IS, IT, LT, LU, LV, MC, MK, MT, NL, NO, PL, PT, RO, RS, SE, SI, SK, SM, TR), OAPI (BF, BJ, CF, CG, CI, CM, GA, GN, GQ, GW, ML, MR, NE, SN, TD, TG).

[Fortsetzung auf der nächsten Seite]

(54) Title: TEST SYSTEM AND METHOD FOR CONTROLLING THE ORIENTATION OF A TEST STRIP

(54) Bezeichnung : TESTSYSTEM UND VERFAHREN ZUR KONTROLLE DER AUSRICHTUNG EINES TESTSTREIFENS

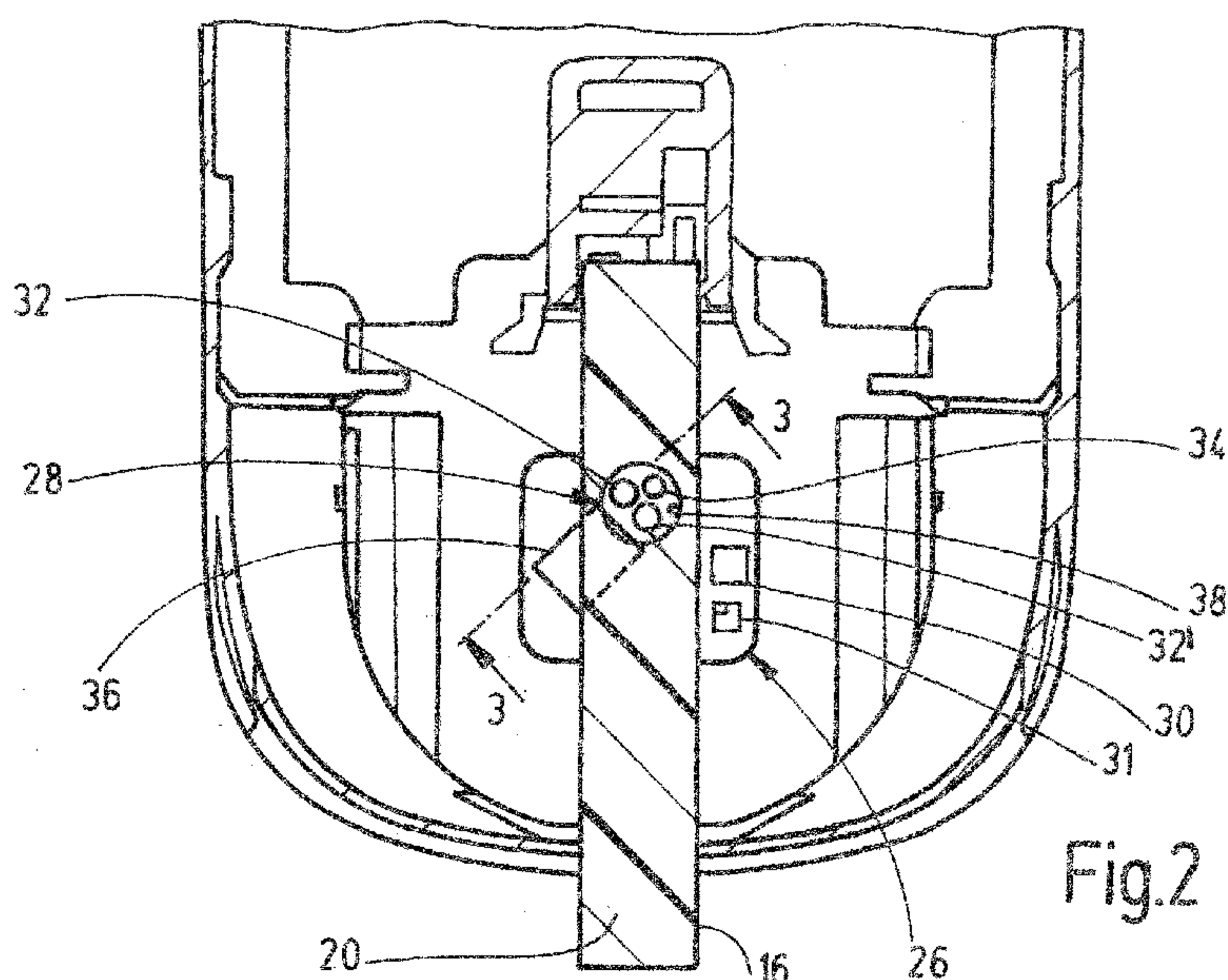

Fig.2

(57) Abstract: The invention relates to a test system for analyzing a bodily fluid, in particular for determining the blood glucose level, comprising a test strip (16) which has an analytical test field (22), a photometric measuring unit (28) for detecting remission measurement values on the test field (22) which can be supplied with bodily fluid, a test strip support (14) for orienting the test strip (16) relative to the measuring unit (28), and a control unit (26) for controlling the test strip orientation. According to the invention, the measuring unit (28) detects at least one respective remission measurement value at different wavelengths, and the control unit (26) ascertains a correct or an incorrect test strip orientation by comparing the remission measurement values detected at the different wavelengths with specified reference values.

(57) Zusammenfassung: Die Erfindung betrifft ein Testsystem

[Fortsetzung auf der nächsten Seite]

WO 2013/135669 A1 **Veröffentlicht:**

- mit internationalem Recherchenbericht (Artikel 21 Absatz 3)

für die Analyse einer Körperflüssigkeit, insbesondere zur Blutzuckerbestimmung, mit einem ein analytisches Testfeld (22) aufweisenden Teststreifen (16), einer photometrischen Messeinheit (28) zur Erfassung von Remissionsmesswerten an dem mit Körperflüssigkeit beaufschlagbaren Testfeld (22), einem Teststreifenhalter (14) zum Ausrichten des Teststreifens (16) bezüglich der Messeinheit (28) und einer Kontrolleinheit (26) zur Kontrolle der Teststreifenausrichtung. Erfindungsgemäß wird vorgeschlagen, dass die Messeinheit (28) jeweils mindestens einen Remissionsmesswert bei voneinander verschiedenen Wellenlängen erfasst, und dass die Kontrolleinheit (26) durch einen Vergleich der bei den verschiedenen Wellenlängen erfassten Remissionsmesswerte mit vorgegebenen Referenzwerten eine korrekte oder fehlerhafte Teststreifenausrichtung ermittelt.

WO 2013/135669

PCT/EP2013/054963

Test system and method for monitoring the alignment of a test strip**Description**

5

The invention relates to a test system for analyzing a body fluid, in particular for determining blood sugar levels, comprising a test strip with an analytical test field, a photometric measurement unit for acquiring remission measurement values from the test field to which body fluid can be applied, a test strip holder for aligning the test strip with respect to the measurement unit and a monitoring unit for monitoring the test strip alignment, wherein the test field lies in an optical path of the measurement unit in the case of correct alignment and a network covering the test field on one side or a carrier film of the test strip as in each case a uniform test strip region lies in said path in the case of an incorrect alignment. The invention furthermore relates to a method for monitoring the alignment of a test strip in such a test system.

EP 1 213 579 has disclosed an analysis system with a position monitoring unit, which is configured to identify vertical positional deviations, i.e. longitudinal bending along the test strip. There, a separate monitoring light-emitting diode is arranged in such a way that, if the test field is positioned as intended, no radiation undergoing specular reflection is incident on the detector, whereas, if the free test strip end is bent, increasing amounts of radiation which has undergone specular reflection is incident on the detector and the monitoring signal increases. In this case, the test strips are provided with a recess at their front (distal) end which, in the case of a correct distal alignment, engage in a pin. Furthermore, the prior art has disclosed test systems in which the test strip has a special marking, for example a black

bar, with the aid of which it becomes possible to identify the positioning of the test strip in the measurement instrument.

- 5 Proceeding from this, the invention is based on the object of further improving the systems and methods known from the prior art and of ensuring the reliability of the measurement process on the part of both the instrument and the consumables with as little
10 design and production outlay as possible. In particular, it is intended that erroneous analysis results and possible test repetitions due to incorrect alignments of the test strip be avoided.
- 15 In order to solve this problem, the combination of features found in the independent patent claims is proposed. Advantageous embodiments and developments of the invention emerge from the dependent claims.
- 20 The invention proceeds from the concept of being able to determine correct positioning from possible incorrect positioning by the occurrence of, in principle, different remission values as a result of using at least two light sources with spectrally
25 differing intensity distributions. Accordingly, in view of a measurement system, what is proposed is that the measurement unit respectively acquires at least one remission measurement value at differing wavelengths and that the monitoring unit establishes a correct or
30 incorrect test strip alignment by comparing the remission measurement values acquired at the different wavelengths with predetermined reference values. As a result, it is possible to dispense with a separate light source or an additional detector for identifying
35 the position. Moreover, additional markings are not required on the test strip since scanning a uniformly structured test strip region at different wavelengths enables reliable differentiation between the analysis

region of the test field and, lying over this, the spreading network at the front strip end and the carrier film at the rear end. Therefore, it is possible to identify, in particular, such incorrect positions which are based on interchanging top and bottom or front and back of the test strip during handling by the user. Since incorrect measurements may have fatal consequences, particularly in the field of blood sugar monitoring, the invention achieves an increased degree of usage safety.

Advantageously, monitoring or measurement values differing with respect to wavelength are obtained by virtue of the measurement unit comprising two light sources, preferably formed by light-emitting diodes, emitting at different wavelengths. Therefore, the different light sources differ in terms of the spectral intensity distributions thereof, while, together, they are directed at a uniform test strip region. Here, the test strip region can be formed by the test field, the network or the carrier film, depending on the orientation of the test strip.

It is expedient, both in terms of monitoring the position and in terms of the actual analysis process, if the measurement unit acquires a first remission measurement value in a first wavelength range from 600 to 700 nm, preferably at approximately 660 nm, and a second remission measurement value in a second wavelength range from 710 to 800 nm, preferably at approximately 770 nm.

A further improvement in the measurement success can be achieved by virtue of the measurement unit comprising three light sources, wherein two light sources of the same type, emitting with a corresponding wavelength, are directed at different measurement zones within a uniform region of the test strip.

A further structural simplification emerges from the measurement unit comprising a photodetector interacting with a plurality of light sources, for wavelength-
5 dependent acquisition of remission measurement values. Therefore, the photodetector forms a broadband sensor unit which acquires measurement values of the light source at the different wavelengths.

10 In order to enable reliable distinction from the away-facing analysis side of the test field, it is advantageous if the network is adapted in such a way that it has a significantly different remission
15 coefficient at the different wavelengths of the acquired remission measurement values. Such a difference is considered to be significant if it lies outside of tolerances or errors of the individual measurements at the different wavelengths.

20 In order to increase the wavelength-dependent difference in the remission, it is advantageous if the network has a coloring which only absorbs well at one of the wavelengths used. Green coloring is preferably
25 selected so as to make the sample application of, in particular, blood samples even clearer.

Advantageously, the monitoring unit comprises a memory for storing the reference values and an electronic processor for comparing the remission measurement
30 values with the stored reference values.

In a manner particularly advantageous for the self-monitoring of patients, the monitoring unit and the measurement unit are arranged in a hand-held
35 instrument, wherein the test strip designed for single use can be inserted into a test strip holder embodied on the hand-held instrument.

In respect of the method, the object set forth at the outset is achieved by virtue of a test strip provided with an analytical test field being inserted into a test strip holder and, in the process, aligned with respect to a photometric measurement unit, wherein the test field, to which body fluid is or can be applied, for acquiring remission values lies in an optical path of the measurement unit in the case of correct alignment, and by virtue of in each case at least one remission measurement value being acquired from the inserted test strip at different wavelengths and by virtue of a correct or incorrect test strip alignment being established by comparing the remission measurement values acquired at the different wavelengths with predetermined reference values. Using this, it is equally possible to obtain the advantages already described above with reference to a test system.

A further advantageous aspect of acquiring the remission values which differ in terms of their wavelengths lies in the fact that usage monitoring of the test strip can be performed by comparing the remission measurement values acquired at the different wavelengths with one another, wherein the test strip is determined as usable if a difference between the remission measurement values is below a predetermined absolute value.

Advantageously, only components, in particular light sources of the measurement unit, which are also used for photometrically determining an analyte in the body fluid, are used for monitoring the alignment or usage state of the test strip.

A correct test strip alignment is advantageously determined if all acquired remission measurement values lie in an expectation range between an upper and a

lower reference value. Conversely, an incorrect test strip alignment can already be determined if at least one remission measurement value lies outside of this expectation range.

5

An incorrect alignment and/or usage state of the test strip should be output for a user by means of an error message, whereas, in the case of a correct alignment and optionally acquired usage capability of the test strip, the analyte can readily be determined by means of the photometric measurement unit.

10

In the following text, the invention will be explained in more detail on the basis of an exemplary embodiment schematically depicted in the drawing. In detail:

15

figure 1 shows a perspective view of a test system comprising a blood sugar measurement instrument with an inserted test strip;

20

figure 2 shows a partial section of the test system in the plane of the test strip; and

25

figure 3 shows a section through the line 3-3 in figure 2.

The test system 10 depicted in figure 1 comprises a portable hand-held instrument 12 and a disposable test strip 16, which can be inserted into an instrument-side test strip holder 14, for a single test of a liquid sample, in particular for determining glucose in a blood sample, wherein the measurement result is output on a display 18.

30

The test strip 16 with the rectangular outline has a carrier film 20 made of plastic and a multi-ply test field 22, applied thereon, with a dry chemical reagent layer which, on the upper side, is covered by a network

35

24 for areal distribution of a body fluid (blood, possibly also tissue liquid or something else) applied from above. The network 24 is formed by a tightly meshed fabric, which takes up the sample and distributes it over an area or spreads it with a capillary action. Reactants within the reagent layer react irreversibly with an analyte (e.g. glucose) in the applied fluid. The optically detectable change in the remission coefficient thus caused can be detected on the lower side of the reagent layer (side lying opposite the network 24), wherein a measurement window is provided by a recess or a transparent material of the carrier film 20. Further details in this respect can be gathered from e.g. EP 821 233 and EP 821 234, to which explicit reference is made in this context.

The test strip 16 is positioned in the test strip holder 14 by the user himself, wherein restricted capabilities of patients may possibly also need to be taken into account. Thus, in addition to the alignment in the correct position, as shown in figure 1, incorrect alignments are also possible due to the rectangular strip geometry, within the scope of which incorrect alignments the network 24 points downward toward the interior of the instrument or the proximal strip end is pushed into the instrument 12 leading with the upper or lower side of the carrier film 20.

In order to identify such incorrect alignments, a monitoring unit 26, functionally connected to a reflection photometric measurement unit 28 also provided for the analysis, is provided in the instrument 12, as shown symbolically in figure 2. The monitoring unit 26 accesses the remission measurement values from the measurement unit 28 by means of a signal processor 30 and accesses a memory 31 for reference values for the purposes of identifying the position, as explained in more detail below.

The measurement unit 28 comprises three light-emitting diodes 32, 32', 34 and a photodetector 36 e.g. embodied as photodiode. The light-emitting diodes 32, 32',
5 preferably with the same design, are arranged with the same lateral distance from the receiver surface of the detector 36 and emit red light at a first wavelength of e.g. 660 nm, while the remaining light-emitting diode 34 emits in the near infrared range at a second
10 wavelength of e.g. 770 nm. A measurement hole 38 in the carrier film 20 of the test strip 16 enables optical scanning of the test field 22 from the lower side thereof. It is also possible for the two light-emitting diodes 32, 32' at the same distance to emit at
15 different wavelengths or for, overall, only two light-emitting diodes at different wavelengths to be used.

Figure 3 shows the beam path or optical path of the measurement unit 28 in relation to the test field 22 of
20 the test strip 16. A collecting lens 40 is arranged over each light-emitting diode 32, 32', 34, which collecting lens focuses the emitted light 42 on the rear side on the test field 22 to which body fluid 44 has been applied. The light 46 diffusely reflected
25 therefrom reaches the detector 36 via a transparent window 48, while a directed specular reflection into the reception region is avoided and direct light crosstalk is prevented by a barrier 50 between the light-emitting diodes 32, 32', 34 and the detector 36.
30 The acquired remission measurement values depend on what wavelengths of the light from the light-emitting diodes 32, 32', 34 are absorbed or diffusely reflected more strongly on the irradiated surface.

35 In order to identify the position of the test strip 16, the signal processor 30 of the monitoring unit 16 can be used to compare the remission values captured at the different wavelengths of the light-emitting diodes 32,

32', 34 to reference values stored in the memory 31 and a correct or incorrect test strip alignment can be established as a result of the comparison. The following table discloses, in an exemplary manner, measurement values of the remission coefficient, from which the correct position of the test strip 16 can be established uniquely:

Alignment over the measurement unit	LED 32 660 nm	LED 34 770 nm	LED 32' 660 nm	Result
Test field	58.5%	57.9%	60.7%	Correct
Network	15.6%	45.3%	11.2%	Incorrect
Carrier film (top)	91.2%	86.5%	81.4%	Incorrect
Carrier film (bottom)	85.2%	86.9%	73.5%	Incorrect

The remission coefficient specifies the ratio of the luminance diffusely reflected by the surface in the measurement direction to the luminance of a surface in the reference white. The light-emitting diodes 32, 32' are directed at different measurement zones and can also cause slightly different measurement values due to design tolerances.

A correct test strip alignment is determined if all acquired remission measurement values lie in an expectation range between 45% and 70%. These values are underlined in the table. Hence, the orientation or alignment in which the test field 22 points downward to the measurement unit 28 can uniquely be identified as correct. The expectation range can depend on the production batch of the test strips and may optionally be determined empirically depending on the age thereof.

An incorrect test strip alignment is determined if at least one remission measurement value lies outside of the expectation range of 45% to 70%. The network 24 absorbs more strongly at 660 nm than at 770 nm, and so

the short-wavelength values in this case lie significantly outside of the expectation range. This effect can be amplified by a suitable color of the fabric threads of the network 24. Green coloring is expediently selected such that the user can also identify the application of blood well. The white carrier film 20 mainly reflects the light irradiated thereon, largely independently of the wavelength difference, as a result of which all measurement values lie above the expectation range in this alignment.

A further monitoring option as a result of the wavelength-dependent measurement emerges in respect of the usage state of the test strip 16. If an already used test strip, even with a low glucose concentration of less than e.g. 50 mg/dl in the applied blood sample, is used again for a second measurement, this results in a remission value difference at the different wavelengths due to darker discoloring of the test field 22. Therefore, less light is diffusely reflected in the red region compared to the near infrared region. If the magnitude of the measurement value difference lies above a predetermined threshold of e.g. 5%, it is possible to deduce a preceding use, while the test strip is categorized as new or unused in the region therebelow.

In the case of an incorrect alignment, an error message is output to the user on the display 18 such that the incorrect alignment can be removed and the analysis then can be performed reliably using the same test strip 16. Negative usage monitoring can likewise be displayed so as to discard the test strip.

The analyte can be determined using the already above-described components of the measurement unit 28, wherein, in addition to the two measurement LEDs 32, 32' with preferably the same design, the third LED 34

WO 2013/135669

- 11 -

PCT/EP2013/054963

situated further away from the detector 36 supplies a signal for monitoring wetting. Hence, in order to identify the position, no additional components are required in the instrument and no markings are required
5 on the test strip 16.

Patent claims

1. A test system for analyzing a body fluid, in particular for determining blood sugar levels, comprising a test strip (16) with an analytical test field (22), a photometric measurement unit (28) for acquiring remission measurement values from the test field (22) to which body fluid can be applied, a test strip holder (14) for aligning the test strip (16) with respect to the measurement unit (28) and a monitoring unit (26) for monitoring the test strip alignment, wherein the test field (22) lies in an optical path (42, 46) of the measurement unit (28) in the case of correct alignment and a network (24) covering the test field (22) on one side or a carrier film (20) of the test strip (16) lies in said path in the case of an incorrect alignment, **characterized** in that the measurement unit (28) respectively acquires at least one remission measurement value at differing wavelengths and in that the monitoring unit (26) establishes a correct or incorrect test strip alignment by comparing the remission measurement values acquired at the different wavelengths with predetermined reference values.
2. The test system as claimed in claim 1, **characterized** in that the measurement unit (28) comprises two light sources (32, 34), preferably formed by light-emitting diodes, emitting at different wavelengths.
3. The test system as claimed in claim 1 or 2, **characterized** in that the measurement unit (28) acquires a first remission measurement value in a first wavelength range from 600 to 700 nm, preferably at approximately 660 nm, and a second

remission measurement value in a second wavelength range from 710 to 800 nm, preferably at approximately 770 nm.

- 5 4. The test system as claimed in one of claims 1 to
3, **characterized** in that the measurement unit (28)
comprises three light sources (32, 32', 34),
wherein two light sources (32, 32') emitting with
a corresponding wavelength are directed at
10 different measurement zones.
5. The test system as claimed in one of claims 1 to
4, **characterized** in that the measurement unit (28)
comprises a photodetector (36) interacting with a
15 plurality of light sources, for wavelength-
dependent acquisition of remission measurement
values.
6. The test system as claimed in one of claims 1 to
20 5, **characterized** in that the network (24) has a
significantly different remission coefficient at
the different wavelengths of the acquired
remission measurement values.
- 25 7. The test system as claimed in one of claims 1 to
6, **characterized** in that the network (24) has
preferably green coloring.
8. The test system as claimed in one of claims 1 to
30 7, **characterized** in that the monitoring unit (26)
comprises a memory (31) for storing the reference
values.
9. The test system as claimed in one of claims 1 to
35 8, **characterized** in that the monitoring unit (26)
comprises an electronic processor (30) for
comparing the remission measurement values with
the reference values.

10. The test system as claimed in one of claims 1 to 9, **characterized** in that the monitoring unit (26) and the measurement unit (28) are arranged in a hand-held instrument (12) and in that the test strip (16) designed for single use can be inserted into a test strip holder (14) embodied on the hand-held instrument.
11. A method for monitoring the alignment of a test strip (16) in a test system for analyzing a body fluid, in particular as claimed in one of the preceding claims, in which test system a test strip (16) provided with an analytical test field (22) is inserted into a test strip holder (14) and, in the process, aligned with respect to a photometric measurement unit (28), wherein the test field (22), to which body fluid is or can be applied, for acquiring remission values lies in an optical path (42, 46) of the measurement unit (28) in the case of correct alignment, **characterized** in that in each case at least one remission measurement value is acquired from the inserted test strip (16) at different wavelengths and in that a correct or incorrect test strip alignment is established by comparing the remission measurement values acquired at the different wavelengths with predetermined reference values.
12. The method as claimed in claim 11, **characterized** in that usage monitoring of the test strip (16) is performed by comparing the remission measurement values acquired at the different wavelengths with one another, wherein the test strip (16) is determined as usable if a difference between the remission measurement values is below a predetermined absolute value.

WO 2013/135669

- 15 -

PCT/EP2013/054963

13. The method as claimed in claim 11 or 12, **characterized** in that only components, in particular light sources (32, 32', 34) of the measurement unit (28), which are also used for photometrically determining an analyte in the body fluid, are used for monitoring the alignment and/or for usage monitoring of the test strip (16).
- 10 14. The method as claimed in one of claims 11 to 13, **characterized** in that a correct test strip alignment is determined if all acquired remission measurement values lie in an expectation range between an upper and a lower reference value, and in that an incorrect test strip alignment is determined if at least one remission measurement value lies outside of the expectation range.
- 15 15. The method as claimed in one of claims 11 to 14, **characterized** in that an error message is output for a user in the case of an incorrect alignment and/or a usage state of the test strip (16).
- 20

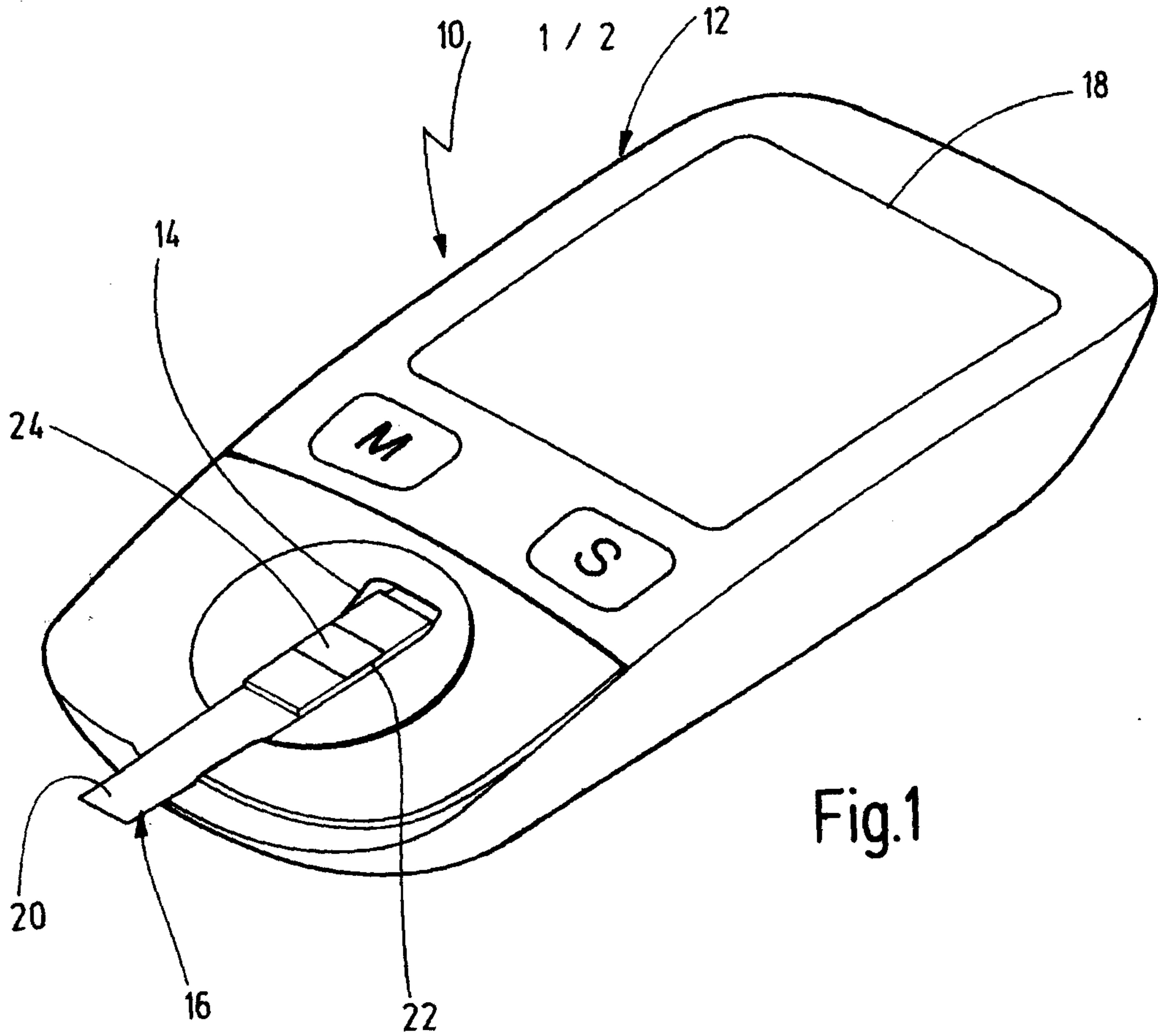

Fig.1

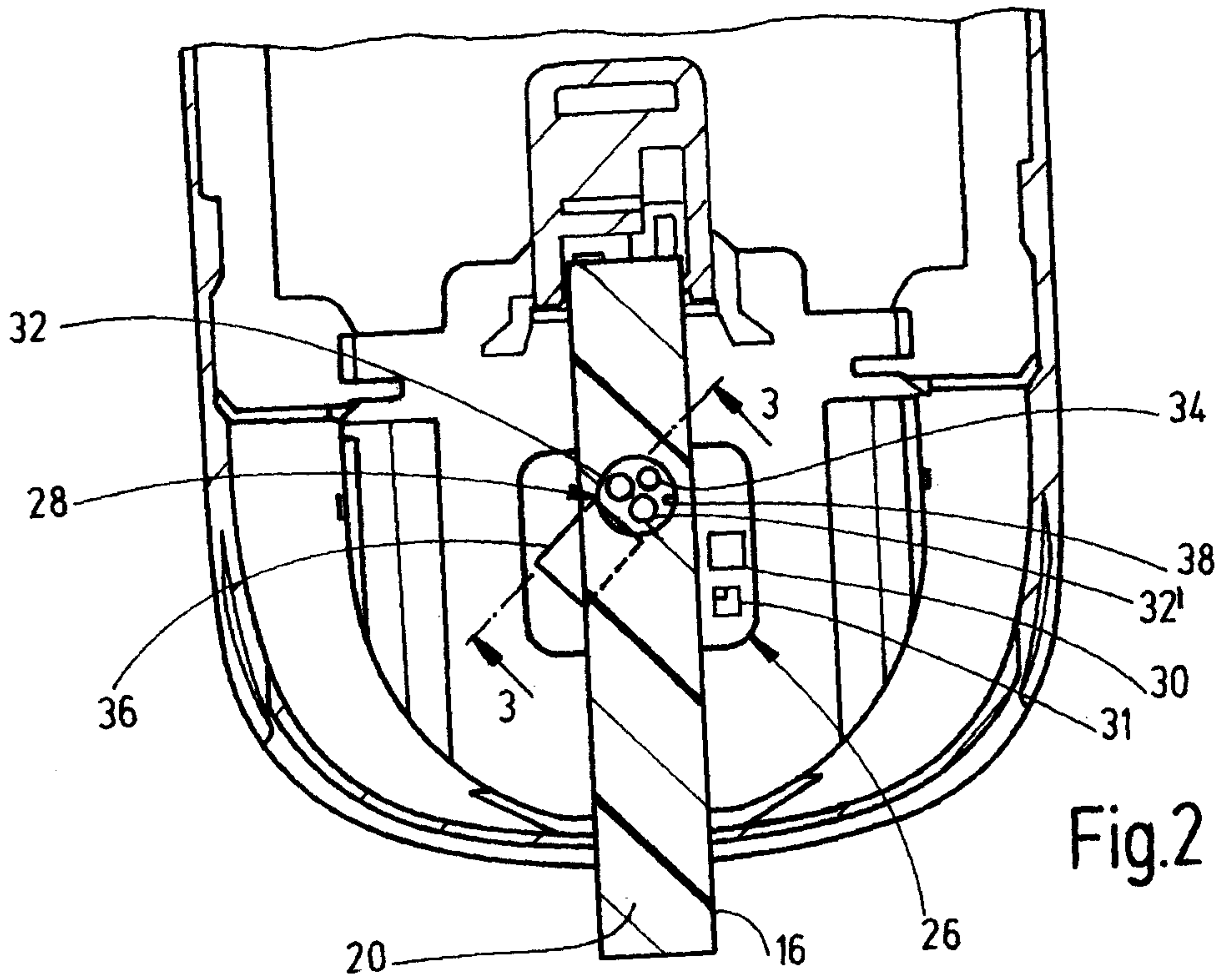

Fig.2

