

(19)



(11)

EP 3 040 618 B1

(12)

EUROPEAN PATENT SPECIFICATION

(45) Date of publication and mention of the grant of the patent:
23.08.2017 Bulletin 2017/34

(51) Int Cl.:
F24B 1/02 ^(2006.01) **A47J 33/00** ^(2006.01)
A47J 37/07 ^(2006.01) **F24B 1/181** ^(2006.01)
F24B 1/182 ^(2006.01) **F24B 1/26** ^(2006.01)

(21) Application number: **14200531.3**

(22) Date of filing: **30.12.2014**

(54) STOVE WITH REMOVABLE BURNING CHAMBER

OFEN MIT ABNEHMBARER BRENNKAMMER

FOURNEAU AVEC CHAMBRE DE COMBUSTION AMOVIBLE

(84) Designated Contracting States:
AL AT BE BG CH CY CZ DE DK EE ES FI FR GB GR HR HU IE IS IT LI LT LU LV MC MK MT NL NO PL PT RO RS SE SI SK SM TR

- **De Heer, Aart Gerardus**
3421 XM Oudewater (NL)
- **Martens, René**
1051 HC Amsterdam (NL)

(43) Date of publication of application:
06.07.2016 Bulletin 2016/27

(74) Representative: **Klavers, Cornelis et al**
Octrooibureau Klavers B.V.
P.O. Box 1642
1300 BP Almere (NL)

(73) Proprietor: **Mimi Moto Holding B.V.**
3235 AC Rockanje (NL)

(56) References cited:
WO-A2-2006/081595 **US-A- 3 266 478**
US-A- 3 791 368 **US-A- 3 868 943**
US-A- 4 730 597 **US-A1- 2006 225 724**
US-B1- 6 615 821 **US-B2- 8 893 703**

(72) Inventors:
 • **Osinga, Anne Jurjen**
3235 AC Rockanje (NL)
 • **Hartog, Merijn**
1121 VZ Landsmeer (NL)

EP 3 040 618 B1

Note: Within nine months of the publication of the mention of the grant of the European patent in the European Patent Bulletin, any person may give notice to the European Patent Office of opposition to that patent, in accordance with the Implementing Regulations. Notice of opposition shall not be deemed to have been filed until the opposition fee has been paid. (Art. 99(1) European Patent Convention).

Description

[0001] The present invention relates to a stove which is suitable for heating and/or cooking.

[0002] Such a stove is generally known. Multi-fuel stoves are for example used in small dwellings, such as in developing countries where the same stove is generally used for cooking and heating purposes. These stoves have a central burning chamber within an outer shell and have air apertures for controlling the burning of generally solid fuel, like wood -pellets, chips or blocks- or remainders thereof, coals such as charcoal, brown coal or the like. When the burning is finished the remaining ash is removed from the burning chamber, usually by turning the stove and depositing the ash remains into a safe storage place.

[0003] US 2006/225724 A1 used to delimit claim 1 there from discloses a stove provided with a burning chamber in the form of a fire bucket defining a burning space and having air openings, fig 3A and rows of air openings, whereby at least one row is arranged above the other, an outer shell surrounding the burning chamber, whereby the burning chamber is detachably supported within the outer shell, supporting means holding the burning chamber in an air space at a distance from an inner wall of the outer shell, an electric fan whose air outlet is connected to the air space between the burning chamber and the inner wall, and connector means for inputting electric energy possibly from a battery, solar cells, computer or telephone. In addition it discloses that the inner wall/shell has air openings.

[0004] US 4730597 A discloses a biomass stove provided with a burning chamber in the form of a removable fuel basket with rows of air inlet openings. Of the rows of air openings in the burning chamber a higher row has air openings with a smaller diameter than a lower row. A multi burner stove is disclosed too.

[0005] US 6615821B1 discloses a portable stove having an inner wall, an outer wall and at least one middle wall nested and affixed centrally to a floor for defining multiple pathways for preheating air before it enters a combustion chamber of the stove.

[0006] US 3266478 A discloses a barbecue apparatus having a box like unit with side by side fireboxes. Each firebox has a bottom grate surrounded by perforated walls which have smaller perforations than the grate. A blower may be used for achieving a forced air draft to the boxes.

[0007] WO 2006/081595 A2 discloses a portable cooking apparatus having a suspended combustion vessel, which has a row of apertures for permitting airflow into a solid fuel combustion zone of the chamber. A secondary vessel also with apertures is interposed between the vessel and an inner shell for permitting air flow through the apparatus.

[0008] US 3791368 A discloses a multipurpose cooking assembly, which can also be used as a stove. A handle attachment structure and a removable handle coop-

erating therewith are described for handling a top cover of the assembly.

[0009] US 3868943 discloses a cooker stove including a electric heater assembly, which is in electrical contact with a battery, and a blower assembly. The blower may be nested in the heater in a position of the cooker. Forced air is blown through space and passages between first, second and third shells to rows of openings formed in a side wall of the stove.

[0010] It is an object of the present invention to provide a light weight multi-fuel stove suitable for heating and/or cooking and equipped to easily remove burning remnants from the stove, which stove has only a few components, is easy to manufacture, maintain and operate, and is cost-price friendly.

[0011] Thereto the stove according to the invention is characterised by the features of claim 1.

[0012] It is an advantage of the stove according to the present invention that the burning chamber is a detachable part of the stove and can be taken out of the stove and carried by any person, in order to empty the lose chamber with its ash in a safe storage place. Due to the low weight of the burning chamber emptying is easy and can be done without spilling or the forming of annoying and harmful dust ash clouds. The empty usually bucket like burning chamber can then easily be -re-filled with burnable materials, carried to the stove and inserted in the stove, ready for a new burning cycle. Advantageously this does not require any transport of the stove as a whole.

[0013] The distance of the burning chamber, with its air openings, from the inner wall of the outer shell safeguards a continuous flow of air through the air space and the air openings to the burning fuel materials in the burning chamber.

[0014] In an embodiment the stove according to the invention is characterised in that the burning chamber is provided with a flange causing the burning chamber to hang in the air space from the top end of the outer shell. The flange may be a radially outward bended flange, preferably provided at the top end of the burning chamber.

[0015] Such a stove having an easy to bend flange can be manufactured in a cost-price friendly way, in particular for use in the developing countries.

[0016] Another embodiment of the stove is characterised in that that the detachable burning chamber is provided with a connection part at its top end, and that the stove has a handle having a complementary connection part, both connection parts being equipped for being as mutually detachably engaging connection parts. In particular the connection part on the burning chamber is an extension, and the connection part of the handle is formed as a wired work, both the extension and the wired work being shaped such that the wired work can be clamped in position around the extension.

[0017] With a simple though effective outline of the connection part of the handle and its complementary connection part on the burning chamber it is easy to remove and insert the burning chamber from the stove.

[0018] With the same handle a further burning chamber possibly present inside the (main) burning chamber can be removed and inserted either individually or simultaneously upon removal or insertion of the main burning chamber.

[0019] Further advantageously the same handle can be used to move the stove as a whole.

[0020] At present the stove according to the invention will be elucidated further together with its additional advantages while reference is being made to the appended drawing, wherein similar components are being referred to by means of the same reference numerals. In the drawing:

Figs. 1a and 1b show a perspective view and an exploded view respectively of a stove according to the invention;

Figs. 2a and 2b show a side view and an upper view respectively of the stove of figs. 1a/1b;

Figs. 3a and 3b show views of possible embodiments of the main burning chamber having air openings and rows of air openings respectively for application in the stove according to fig. 1a/1b, and

Figs. 4a, 4b and 4c show how nested burning chambers can be removed individually and/or together from the air space within the inner wall of the stove.

[0021] Figs. 1a and 1b show in a perspective view and an exploded view respectively a stove 1 for heating and/or cooking, which is provided with a burning chamber 2-1, and an outer shell surrounding the burning chamber 2-1. The outer shell includes a decorative properly coloured outer wall 3-1 on the outside of the stove 1. Within the outer wall 3-1 the outer shell has an inner wall 3-2.

[0022] The outer shell may encompass double walls generally filled with a thermally isolating heat resistant material. In practise the burning chamber 2-1 and at least the inner wall 3-2 of the outer shell may be co-axially and will mostly be circular seen in horizontal cross section. For reasons of brevity this circular, co-axial embodiment will be described hereinafter. The inner wall 3-2 is hollow and defines an inner air space 4, wherefrom the inserted burning chamber 2-1 can be removed. The burning chamber 2-1 is detachably supported in the air space within the inner wall 3-2. The wall of the burning chamber 2-1 will generally be provided with air openings 5, capable of letting through air from the air space 4 to the fuel material inside of the burning chamber 2-1, in the condition wherein the chamber 2-1 is lowered in the air space 4 defined by the inner wall 3-2.

[0023] The stove 1 has supporting means here shown as an flange 6 holding the burning chamber in the air space 4 at a distance from an inner wall 3-2 of the outer shell. This flange 6 causes the burning chamber 2-1 to hang in the air space 4 from the top end of the outer shell. For reasons of improved stability the flange is an annular flange 6 provided at the top end of the burning chamber 2-1. A radially outward bended flange 6 is easy to man-

ufacture.

[0024] The detachable burning chamber 2-1 shown in figs. 2a, 2b, 3a and 3c is provided with a connection part 7-1 at its top end, and the stove 1 has a handle 8 having a complementary connection part 7-2. Both connection parts 7-1 and 7-2 are equipped as mutually detachably engaging connection parts. These parts will here be hooked onto each other as a simple means to remove the burning chamber 2-1 from the air space 4, which eases emptying the burning remains outside the house without transporting the stove 1 as a whole, or to place it back therein possibly holding new materials to be burned.

[0025] It is particularly convenient if the connection part 7-1 on the burning chamber 2-1 is an extension, and the connection part 7-2 of the handle 8 is formed as a wired work, both as shown in the above mentioned figures. Preferably the extension and the wired work being shaped such that the wired work can be clamped or tuned in position on or around the extension.

[0026] The same handle 8 used for moving the chamber 2-1 in and out of the stove 1 can be used to transport the stove as a whole if the outer wall 3-1 of the outer shell has an outer wall with a similar connection part 7-1 as the burning chamber 2-1 for being engaged by the complementary connection part 7-2 of that same handle 8.

[0027] It may be practical to provide a small fire if the burning chamber 2-1 which defines an inner burning space, is provided with a further burning chamber 2-2, which can be inserted in said inner burning space. The chamber 2-2 may also have suitable air openings. Preferably the nestable further burning chamber 2-2 is provided with a connection part 7-1 at its top end, similar to the part 7-1 on the top end flange 6 of the chamber 2-1 for being engaged by the same complementary connection part 7-2 of the handle 8.

[0028] In particular figs. 2a and 2b show that the upper flanges at the top ends of the burning chambers 2-1 and 2-2 lie in an upper plane of the stove 1. For constructional ease the stove 1 is provided with possibly removable braces 9 for clamping an upper flanges supporting ring 10.

[0029] Figs. 3a and 3b each show main burning chambers 2-1 having air openings 5 and rows of air openings -upper openings in fig. 3b- respectively for application in the stove 1.

[0030] The particularly outlined rows with smaller openings on top of and in between larger lower openings appeared to be advantageous in terms of achieving a stable burning yielding quietly burning flames.

[0031] The additional drawings of figs. 4a, 4b and 4c show the way wherein only the outer burning chamber 2-1, or only chamber 2-2 or both chambers 2-1 and 2-2 simultaneously can be hooked onto the one handle 8 by means of the oval shaped connection part 7-2 in combination with the connected holding clip-like parts 7-1 on top of the chambers 2-1 and 2-2.

[0032] As schematically also shown in fig. 1b the stove 1 is provided with an electric fan 11 whose air outlet is

connected to the air space 4. In that case the stove 1 is also provided with connector means 12 for inputting electric energy such as from a battery, solar cells, computer or telephone, either or not provided with solar cells.

[0033] The upper part of the stove 1 may be provided with either or not removable cooking pan supports, which may be the braces 9, whereon a backing or cooking pan can be placed. The stove 1 may also hold a suitable grill plate.

[0034] As shown the stove 1 is provided legs 13, which may be telescopically extendable in order to conveniently lift the stove 1.

Claims

1. A stove (1) provided with:

- a burning chamber (2-1) defining a burning space and having air openings (5) and rows of air openings, whereby at least one row is arranged above the other,
- an outer shell surrounding the burning chamber (2-1), whereby the burning chamber (2-1) is detachably supported within the outer shell,
- supporting means (6) holding the burning chamber (2-1) in an air space (4) at a distance from an inner wall (3-2) of the outer shell,
- an electric fan (11) whose air outlet is connected to the air space (4) between the burning chamber (2-1) and the inner wall (3-2), and connector means (12) for inputting electric energy possibly from a battery, solar cells, computer or telephone,

characterised in that:

- of the rows of air openings (5) in the burning chamber (2-1) a higher row has air openings with a smaller diameter than a lower row, and that
- the stove (1) is provided with a further burning chamber (2-2) having rows of air openings (5), which further burning chamber (2-2) can be inserted in the burning space of the burning chamber (2-1), such as to form nested burning chambers (2-1, 2-2) which can be removed individually and/or together from the air space within the inner wall (3-2) of the stove (1).

2. Stove (1) according to claim 1, **characterised in that** the burning chamber (2-1; 2-2) is provided with a flange (6) causing the burning chamber (2-1) to hang in the air space (4) from the top end of the outer shell.
3. Stove (1) according to claim 2, **characterised in that** the flange (6) is a radially outward bended flange, preferably provided at the top end of the burning chamber (2-1; 2-2).

4. Stove (1) according to any one of the claims 1-3, **characterised in that** the detachable burning chamber (2-1; 2-2) is provided with a connection part (7-1; 7-1) at its top end, and that the stove (1) has a handle (8) having a complementary connection part (7-2), both connection parts (7-1, 7-2) being equipped for being as mutually detachably engaging connection parts.
5. Stove (1) according claim 4, **characterised in that** the connection part (7-1; 7-1) on the burning chamber (2-1; 2-2) is an extension, and that the connection part (7-2) of the handle (8) is formed as a wired work, both the extension and the wired work being shaped such that the wired work can be clamped in position around the extension.
6. Stove (1) according to any one of the claims 4 or 5, **characterised in that** the outer shell has an outer wall (3-1) having a connection part (7-1) for being engaged by the complementary connection part (7-2) of the handle (8).
7. Stove (1) according to any one of the claims 4-6, **characterised in that** the further burning chamber (2-2) is provided with a connection part (7-1) at its top end for being engaged by the complementary connection part (7-2) of the handle (8).
8. Stove (1) according to any one of the claims 1-7, **characterised in that** the outer shell encompasses double walls (3-1, 3-2) filled with a thermally isolating heat resistant material.
9. Stove (1) according to any one of the claims 1-8, **characterised in that** the upper flanges (6) at the top ends of the burning chambers (2-1, 2-2) lie in an upper plane of the stove, and that the stove (1) is provided with possibly removable braces (9) for clamping an upper flanges supporting ring (10).
10. Stove (1) according to claim 9, **characterised in that** the upper part of the stove (1) is provided with a possibly removable support, such as for a cooking pan or a grill plate.
11. Stove (1) according to any one of the claims 4-10, **characterised in that** only the outer burning chamber (2-1), or only the further burning chamber (2-2) or both chambers (2-1, 2-2) simultaneously can be hooked onto the one handle (8) by means of the oval shaped connection part (7-2) in combination with the connection parts (7-1) which are in the form of holding clip-like parts on top of the chambers (2-1, 2-2).
12. Stove (1) according to any one of the claims 1-11, **characterised in that** the burning chamber/chambers (2-1, 2-2) and the outer shell are co-axially, in

particular circularly relative to one another.

Patentansprüche

1. Ofen (1), versehen mit:

- einer Brennkammer (2-1), die einen Brennraum definiert und Luftöffnungen (5) und Reihen von Luftöffnungen aufweist, wobei mindestens eine Reihe über der anderen angeordnet ist,
- einer äußeren Hülle, welche die Brennkammer (2-1) umgibt, wobei die Brennkammer (2-1) lösbar innerhalb der äußeren Hülle gehalten wird,
- Haltemitteln (6), welche die Brennkammer (2-1) in einem Luftraum (4) in einem Abstand von einer inneren Wand (3-2) der äußeren Hülle halten,
- einem elektrischen Lüfter (11), dessen Luftauslass mit dem Luftraum (4) zwischen der Brennkammer (2-1) und der inneren Wand (3-2) verbunden ist, und Anschlussmitteln (12) zum Einspeisen elektrischer Energie, möglicherweise von einer Batterie, Solarzellen, einem Computer oder Telefon,

dadurch gekennzeichnet, dass:

- von den Reihen von Luftöffnungen (5) in der Brennkammer (2-1) eine weiter oben gelegene Reihe Luftöffnungen mit kleinerem Durchmesser aufweist als eine weiter unten gelegene Reihe, und dass
- der Ofen (1) mit einer weiteren Brennkammer (2-2) versehen ist, die Reihen von Luftöffnungen (5) aufweist, wobei die weitere Brennkammer (2-2) in den Brennraum der Brennkammer (2-1) eingesetzt werden kann, derart dass ineinanderliegende Brennkammern (2-1, 2-2) ausgebildet werden, die einzeln und/oder zusammen aus dem Luftraum innerhalb der inneren Wand (3-2) des Ofens (1) herausgenommen werden können.

2. Ofen (1) nach Anspruch 1, **dadurch gekennzeichnet, dass** die Brennkammern (2-1; 2-2) mit einem Flansch (6) versehen ist, der bewirkt, dass die Brennkammer (2-1) vom oberen Ende der äußeren Hülle aus in dem Luftraum (4) hängt.

3. Ofen (1) nach Anspruch 2, **dadurch gekennzeichnet, dass** der Flansch (6) ein radial nach außen gebogener Flansch ist, der vorzugsweise am oberen Ende der Brennkammer (2-1; 2-2) vorgesehen ist.

4. Ofen (1) nach einem der Ansprüche 1-3, **dadurch gekennzeichnet, dass** die lösbare Brennkammer (2-1; 2-2) an ihrem oberen Ende mit einem Verbindungs-

teil (7-1; 7-1) versehen ist und dass der Ofen (1) einen Griff (8) aufweist, der ein komplementäres Verbindungsteil (7-2) aufweist, wobei beide Verbindungsteile (7-1, 7-2) dazu ausgestattet sind, als miteinander lösbar in Eingriff stehende Verbindungsteile zu dienen.

5. Ofen (1) nach Anspruch 4, **dadurch gekennzeichnet, dass** das Verbindungsteil (7-1; 7-1) an der Brennkammer (2-1; 2-2) eine Verlängerung ist und dass das Verbindungsteil (7-2) des Griffs (8) als Drahtgebilde ausgebildet ist, wobei sowohl die Verlängerung als auch das Drahtgebilde derart geformt sind, dass das Drahtgebilde um die Verlängerung herum festgeklemmt werden kann.

6. Ofen (1) nach einem der Ansprüche 4 oder 5, **dadurch gekennzeichnet, dass** die äußere Hülle eine äußere Wand (3-1) aufweist, die ein Verbindungsteil (7-1) zum Ineingriffnehmen durch das komplementäre Verbindungsteil (7-2) des Griffs (8) aufweist.

7. Ofen (1) nach einem der Ansprüche 4-6, **dadurch gekennzeichnet, dass** die weitere Brennkammer (2-2) an ihrem oberen Ende mit einem Verbindungsteil (7-1) zum Ineingriffnehmen durch das komplementäre Verbindungsteil (7-2) des Griffs (8) versehen ist.

8. Ofen (1) nach einem der Ansprüche 1-7, **dadurch gekennzeichnet, dass** die äußere Hülle Doppelwände (3-1, 3-2) umfasst, die mit einem wärmeisolierenden hitzebeständigen Material gefüllt sind.

9. Ofen (1) nach einem der Ansprüche 1-8, **dadurch gekennzeichnet, dass** die oberen Flansche (6) an den oberen Enden der Brennkammern (2-1, 2-2) in einer oberen Ebene des Ofens liegen und dass der Ofen (1) mit möglicherweise abnehmbaren Klammern (9) zum Ankleben eines die oberen Flansche haltenden Rings (10) versehen ist.

10. Ofen (1) nach Anspruch 9, **dadurch gekennzeichnet, dass** der obere Teil des Ofens (1) mit einer möglicherweise abnehmbaren Halterung, wie etwa für eine Kasserolle oder eine Grillplatte, versehen ist.

11. Ofen (1) nach einem der Ansprüche 4-10, **dadurch gekennzeichnet, dass** nur die äußere Brennkammer (2-1) oder nur die weitere Brennkammer (2-2) oder beide Kammern (2-1, 2-2) gleichzeitig mittels des ovalen Verbindungsteils (7-2) in Kombination mit den Verbindungsteilen (7-1), welche die Form von halteklemmenartigen Teilen auf den Kammern (2-1, 2-2) aufweisen, an den einen Griff (8) gehakt werden kann/können.

12. Ofen (1) nach einem der Ansprüche 1-11, **dadurch**

gekennzeichnet, dass die Brennkammer(n) (2-1, 2-2) und die äußere Hülle bezogen aufeinander koaxial, insbesondere kreisförmig, sind.

Revendications

1. Fourneau (1) équipé avec :

- une chambre de combustion (2-1) définissant un espace de combustion et ayant des ouvertures d'air (5) et des rangées d'ouvertures d'air, moyennant quoi au moins une rangée est disposée au-dessus de l'autre,
- une enveloppe extérieure entourant la chambre de combustion (2-1), moyennant quoi la chambre de combustion (2-1) est supportée de façon détachable à l'intérieur de l'enveloppe extérieure,
- des moyens de support (6) maintenant la chambre de combustion (2-1) dans un espace d'air (4) à une distance d'une paroi intérieure (3-2) de l'enveloppe extérieure,
- un ventilateur électrique (11) dont la sortie d'air est raccordée à l'espace d'air (4) entre la chambre de combustion (2-1) et la paroi intérieure (3-2), et des moyens de raccordement (12) pour faire entrer de l'énergie électrique si possible d'une batterie, de cellules solaires, d'un ordinateur ou téléphone,

caractérisé en ce que :

- parmi les rangées d'ouvertures d'air (5) dans la chambre de combustion (2-1), une rangée plus élevée a des ouvertures d'air avec un diamètre plus petit qu'une rangée inférieure, et
- que le fourneau (1) est équipé avec une autre chambre de combustion (2-2) ayant des rangées d'ouvertures d'air (5), laquelle autre chambre de combustion (2-2) peut être insérée dans l'espace de combustion de la chambre de combustion (2-1) de manière à former des chambres de combustion imbriquées (2-1, 2-2) pouvant être retirées individuellement et/ou ensemble de l'espace d'air dans la paroi intérieure (3-2) du fourneau (1).

2. Fourneau (1) selon la revendication 1, **caractérisé en ce que** la chambre de combustion (2-1; 2-2) est équipée d'une collerette (6) faisant en sorte que la chambre de combustion (2-1) est suspendue dans l'espace d'air (4) à partir de l'extrémité supérieure de l'enveloppe extérieure.

3. Fourneau (1) selon la revendication 2, **caractérisé en ce que** la collerette (6) est une collerette courbée radialement vers l'extérieur, de préférence fournie à

l'extrémité supérieure de la chambre de combustion (2-1; 2-2).

4. Fourneau (1) selon l'une quelconque des revendications 1-3, **caractérisé en ce que** la chambre de combustion détachable (2-1; 2-2) est équipée d'une partie de raccordement (7-1; 7-1) à son extrémité supérieure, et **en ce que** le fourneau (1) a une poignée (8) ayant une partie de raccordement complémentaire (7-2), les deux parties de raccordement (7-1, 7-2) étant équipées pour être telles des parties de raccordement de mise en prise mutuellement détachables.

5. Fourneau (1) selon la revendication 4, **caractérisé en ce que** la partie de raccordement (7-1; 7-1) sur la chambre de combustion (2-1; 2-2) est une extension, et que la partie de raccordement (7-2) de la poignée (8) est formée en tant qu'ouvrage filaire, l'extension tout comme l'ouvrage filaire étant mis en forme de manière à ce que l'ouvrage filaire puisse être serré en position autour de l'extension.

6. Fourneau (1) selon l'une quelconque des revendications 4 ou 5, **caractérisé en ce que** l'enveloppe extérieure a une paroi extérieure (3-1) ayant une partie de raccordement (7-1) pour être mise en prise avec la partie de raccordement (7-2) complémentaire de la poignée (8).

7. Fourneau (1) selon l'une quelconque des revendications 4-6, **caractérisé en ce que** l'autre chambre de combustion (2-2) est équipée avec une partie de raccordement (7-1) à son extrémité supérieure pour être mise en prise avec la partie de raccordement (7-2) complémentaire de la poignée (8).

8. Fourneau (1) selon l'une quelconque des revendications 1-7, **caractérisé en ce que** l'enveloppe extérieure englobe des parois doubles (3-1, 3-2) remplies avec un matériau d'isolation thermique résistant à la chaleur.

9. Fourneau (1) selon l'une quelconque des revendications 1-8, **caractérisé en ce que** les collerettes supérieures (6) aux extrémités supérieures des chambres de combustion (2-1, 2-2) se situent dans un plan supérieur du fourneau, et que le fourneau (1) est équipé avec des attaches (9) si possible amovibles pour serrer une bague (10) supportant des collerettes supérieures.

10. Fourneau (1) selon la revendication 9, **caractérisé en ce que** la partie supérieure du fourneau (1) est équipée avec un support si possible amovible, tel que pour une casserole ou une plaque de grill.

11. Fourneau (1) selon l'une quelconque des revendi-

cations 4-10, **caractérisé en ce que** seule la chambre de combustion extérieure (2-1) ou seule l'autre chambre de combustion (2-2) ou les deux chambres (2-1, 2-2) peuvent être simultanément accrochées à la poignée (8) au moyen de la partie de raccordement (7-2) de forme ovale en combinaison avec les parties de raccordement (7-1) qui sont sous la forme de parties semblables à des clips de retenue sur le haut des chambres (2-1, 2-2).

5

10

12. Fourneau (1) selon l'une quelconque des revendications 1-11, **caractérisé en ce que** la chambre de combustion/les chambres de combustion (2-1, 2-2) et l'enveloppe extérieure sont coaxiales, en particulier circulaires les unes par rapport aux autres.

15

20

25

30

35

40

45

50

55

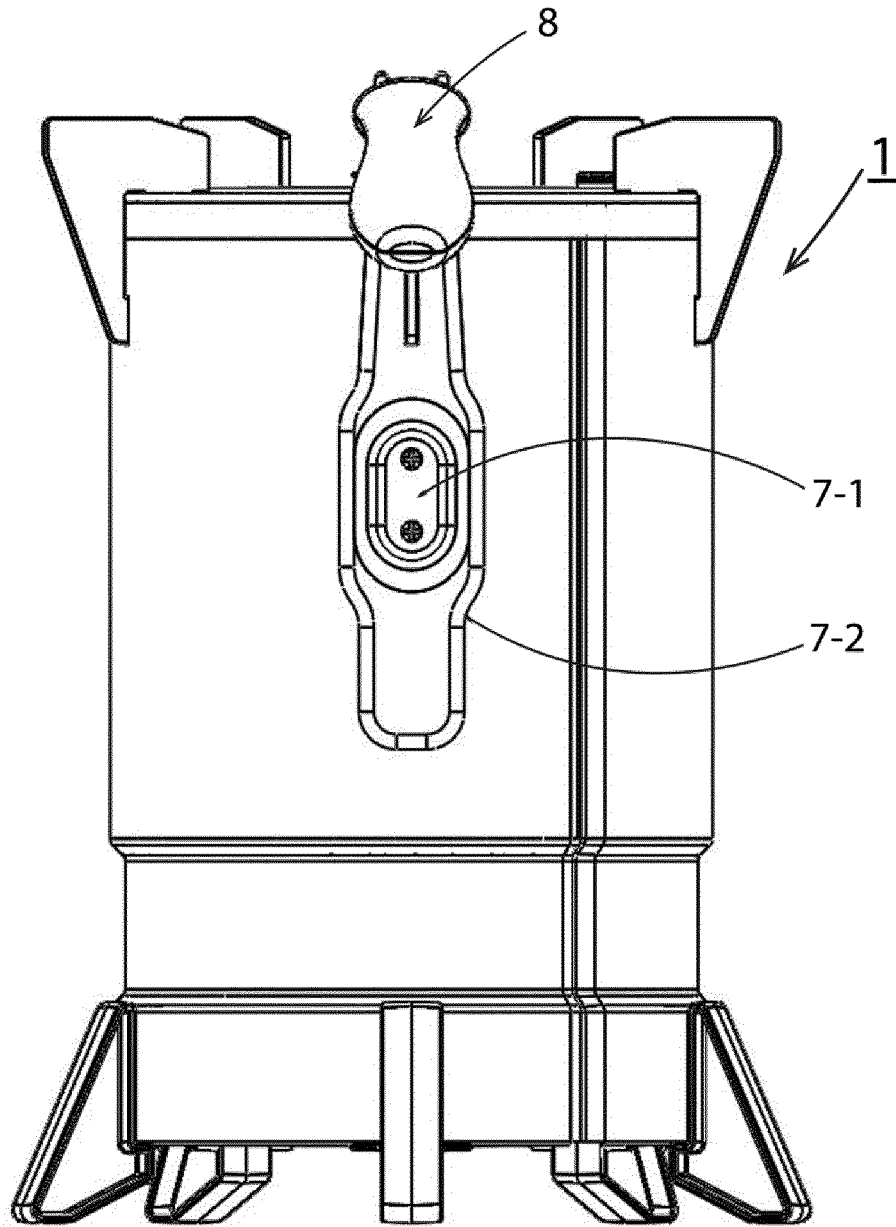

Fig 1a

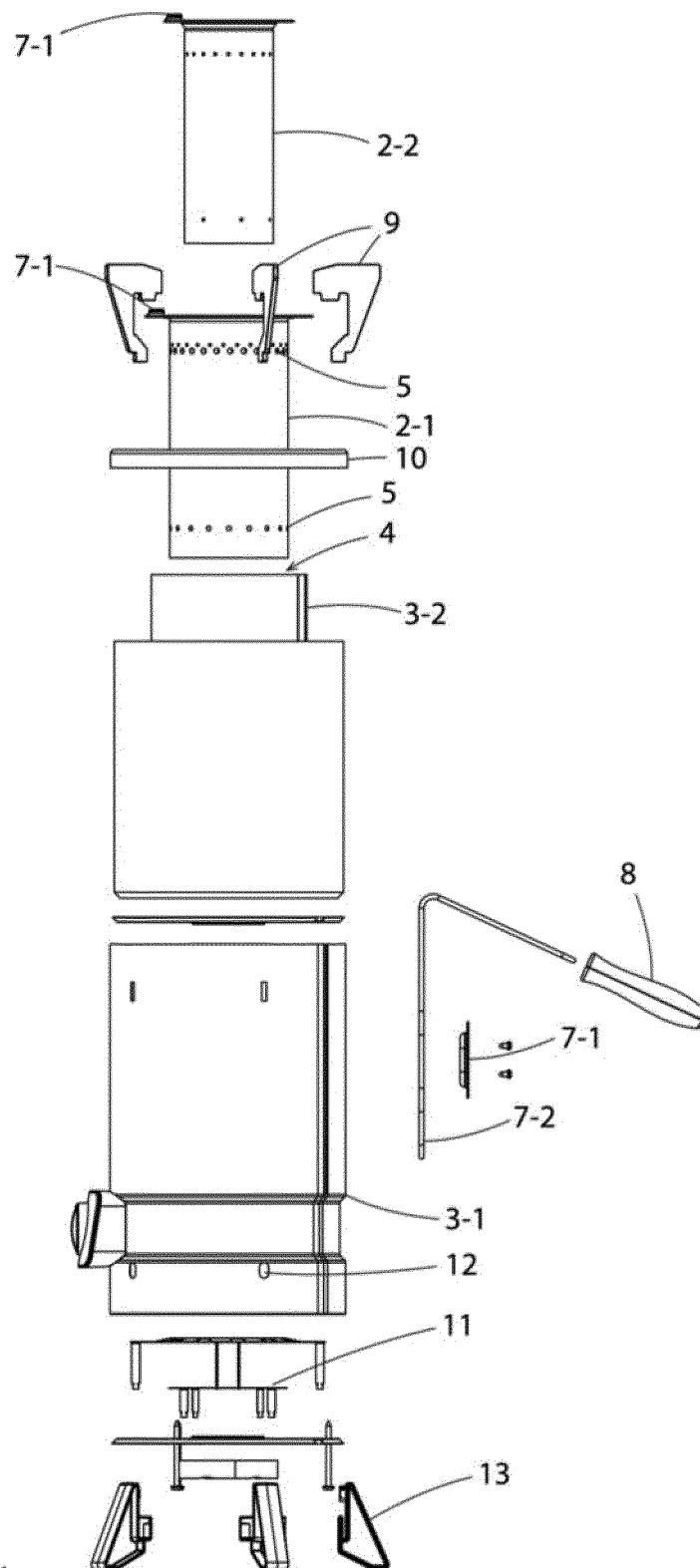

Fig 1b

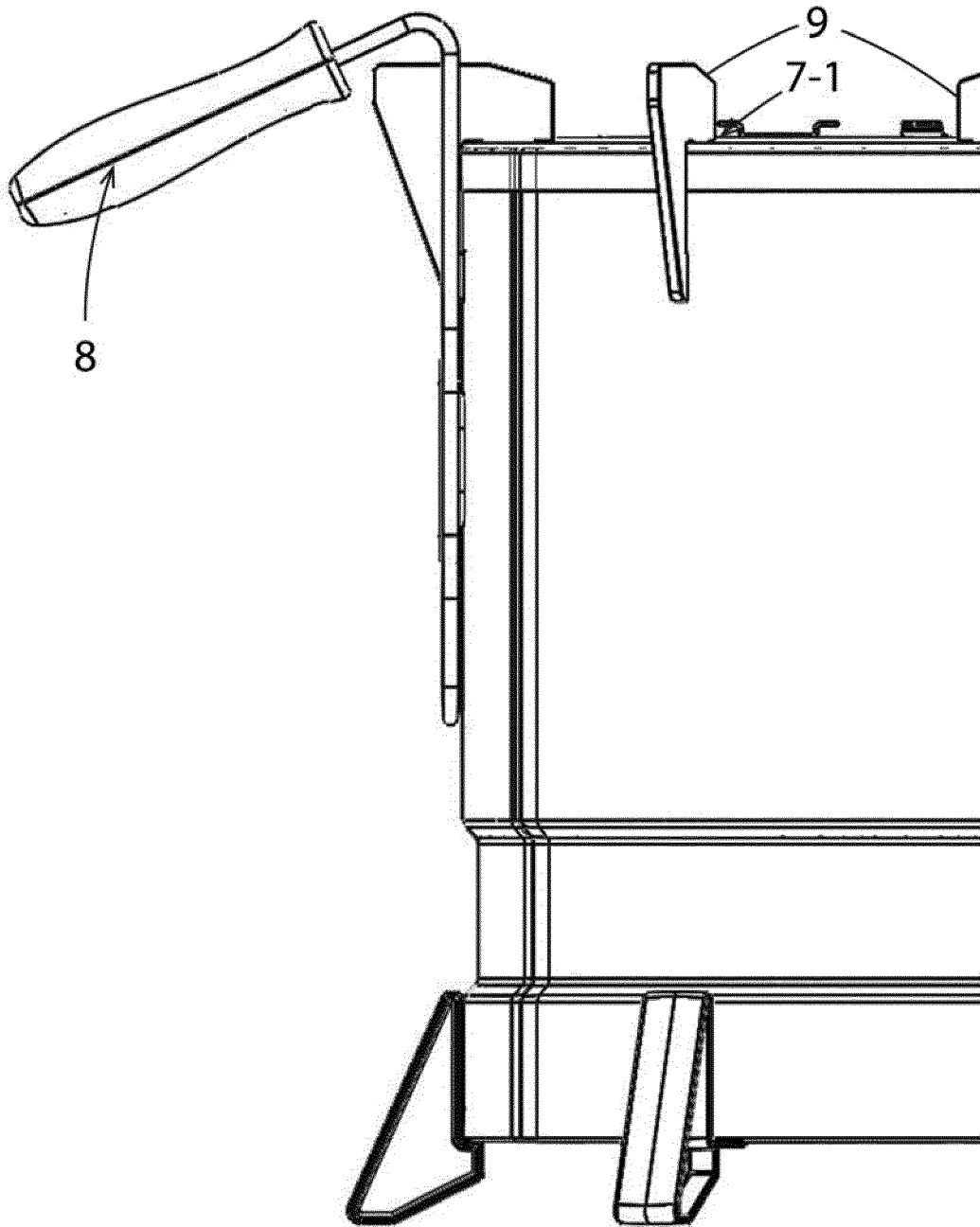

Fig 2a

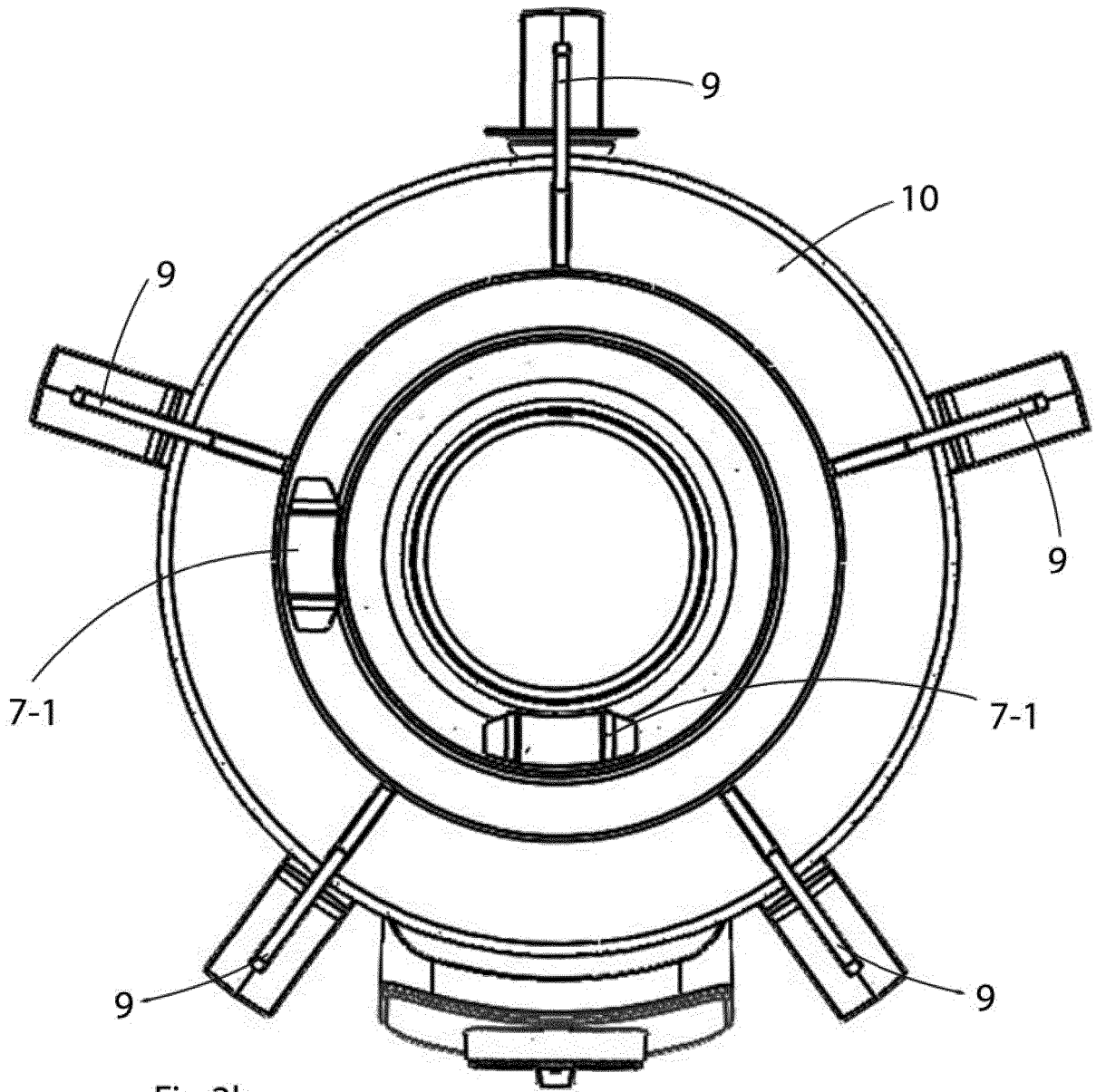

Fig 2b

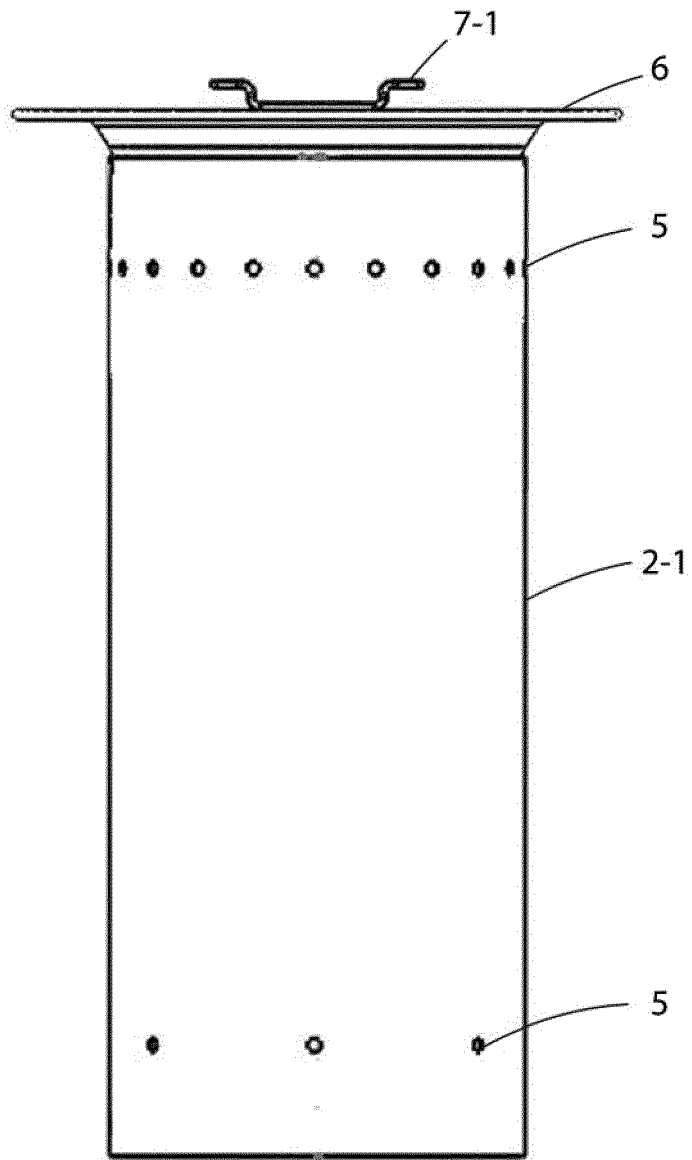

Fig 3a

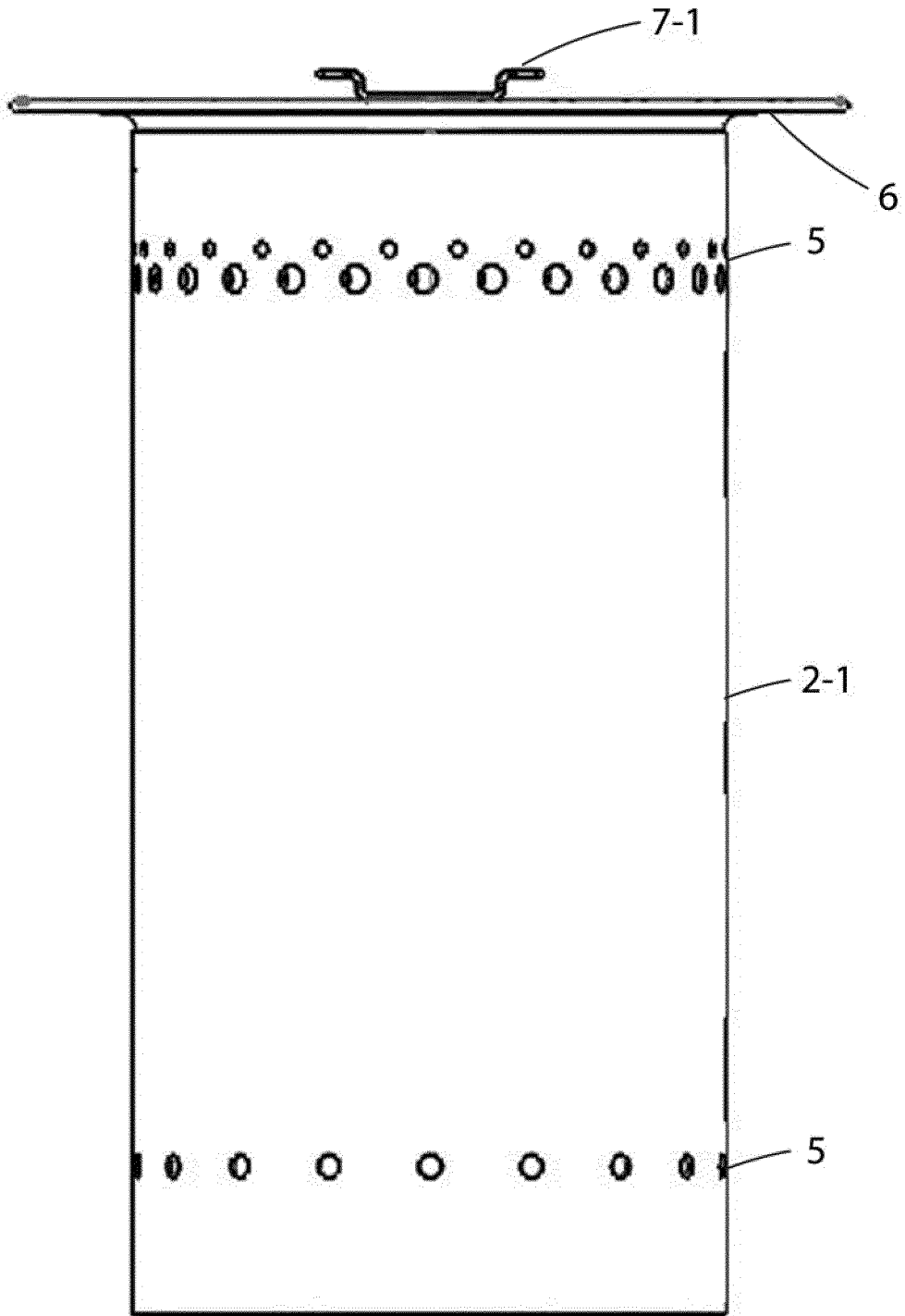

Fig 3b

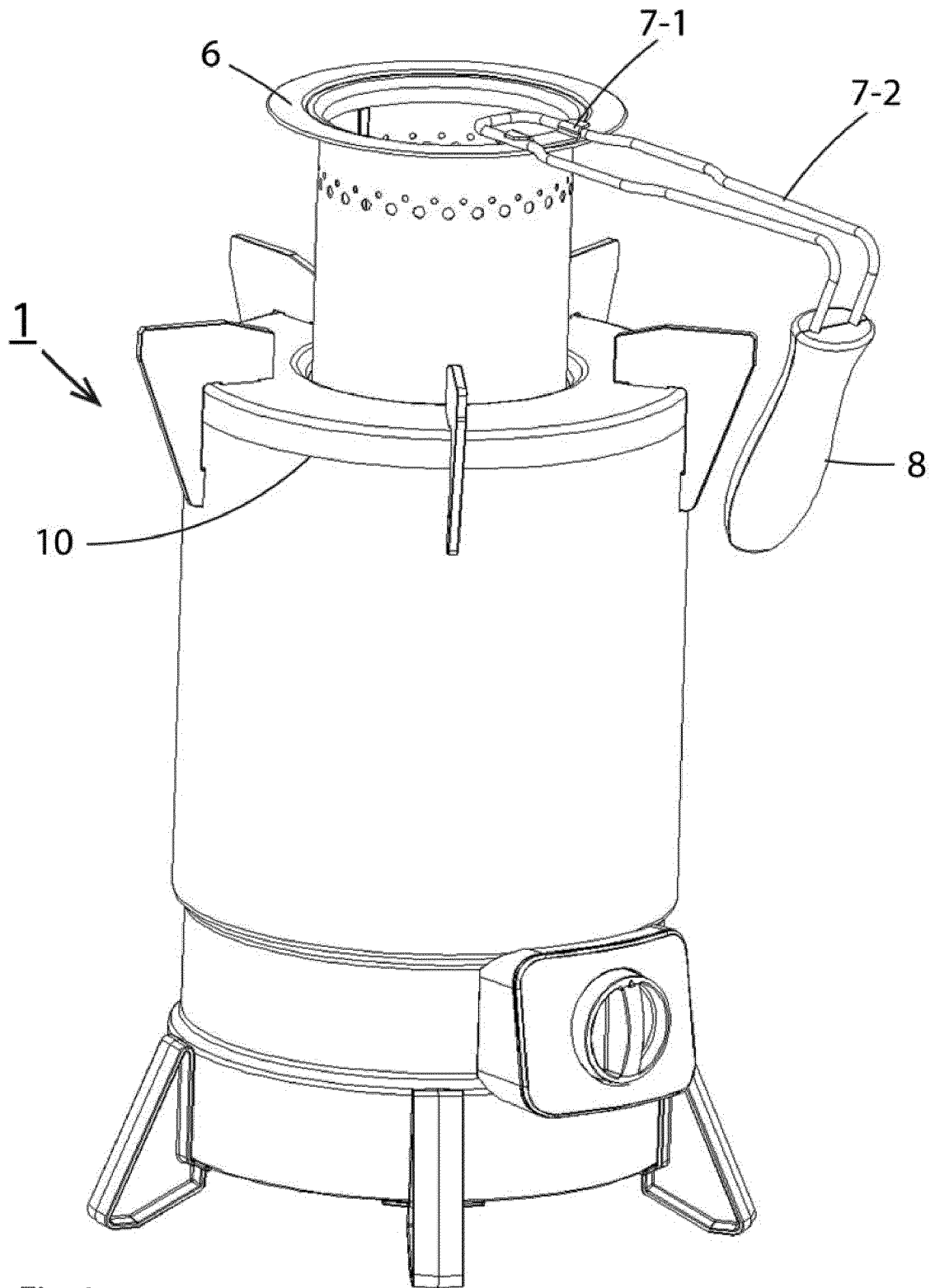

Fig 4a

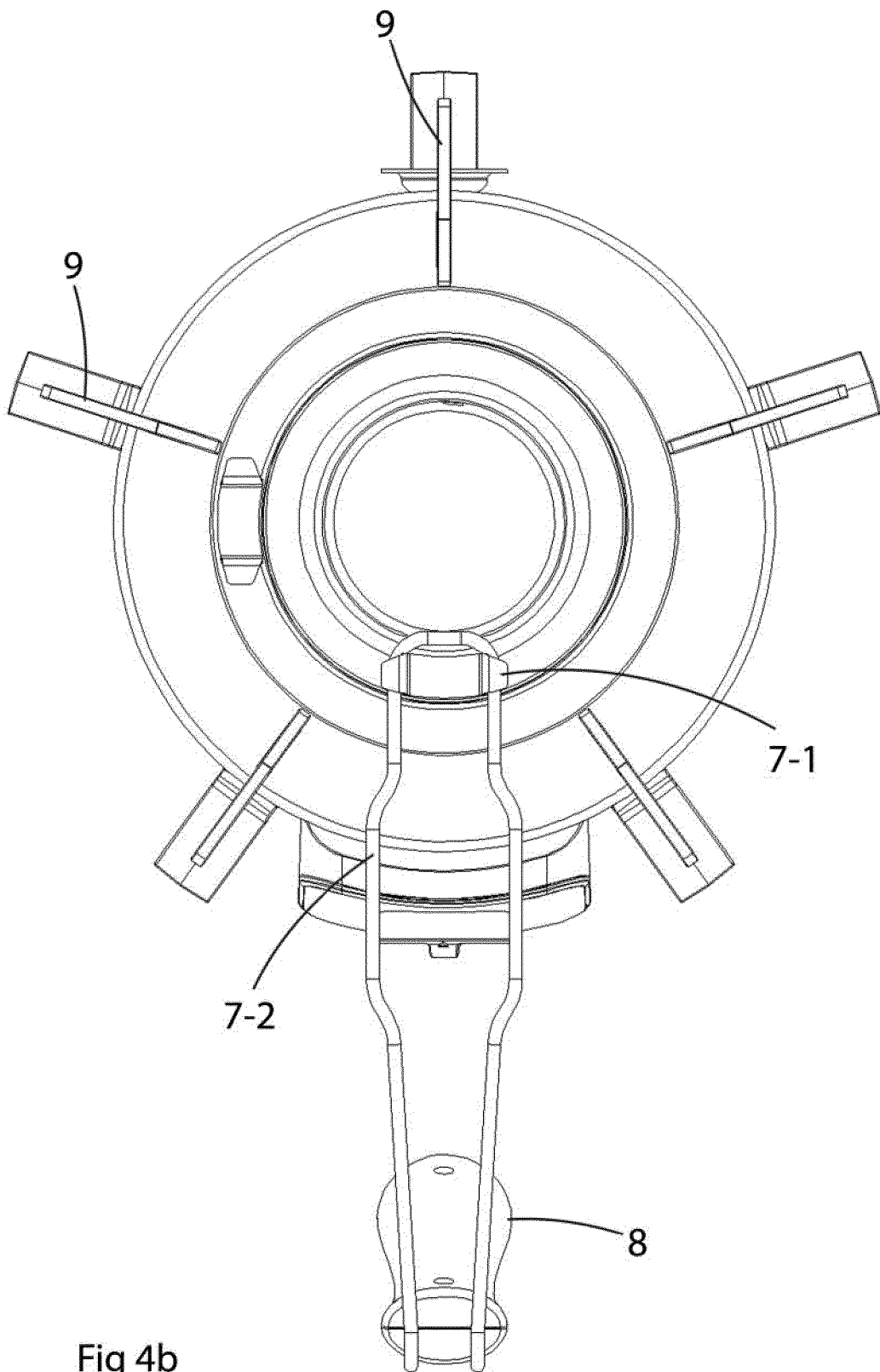

Fig 4b

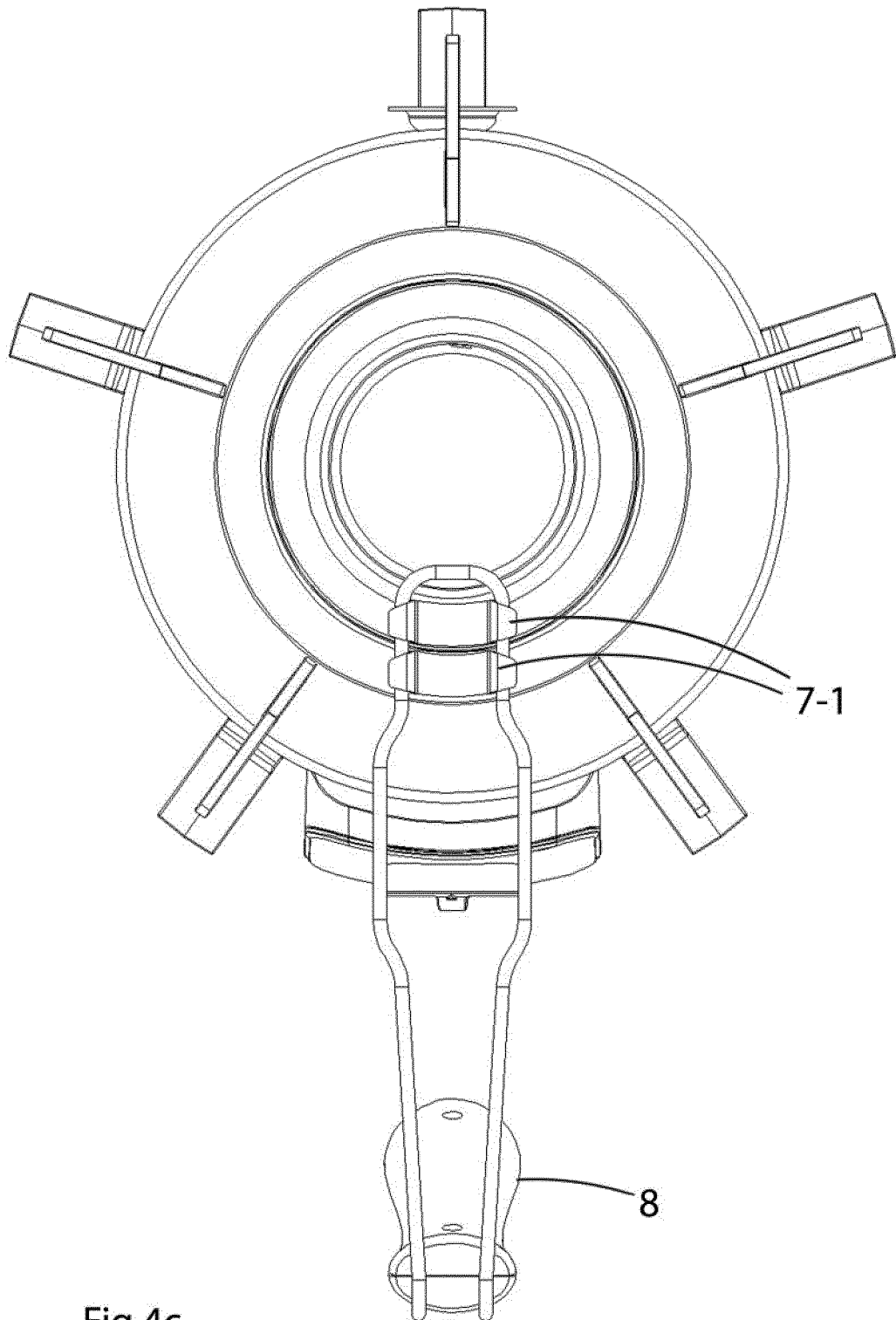

Fig 4c

REFERENCES CITED IN THE DESCRIPTION

This list of references cited by the applicant is for the reader's convenience only. It does not form part of the European patent document. Even though great care has been taken in compiling the references, errors or omissions cannot be excluded and the EPO disclaims all liability in this regard.

Patent documents cited in the description

- US 2006225724 A1 [0003]
- US 4730597 A [0004]
- US 6615821 B1 [0005]
- US 3266478 A [0006]
- WO 2006081595 A2 [0007]
- US 3791368 A [0008]
- US 3868943 A [0009]