



- (51) International Patent Classification:  
C08L 23/08 (2006.01)
- (21) International Application Number:  
PCT/US2014/038944
- (22) International Filing Date:  
21 May 2014 (21.05.2014)
- (25) Filing Language: English
- (26) Publication Language: English
- (30) Priority Data:  
61/826,271 22 May 2013 (22.05.2013) US
- (71) Applicant: **DOW GLOBAL TECHNOLOGIES LLC**  
[US/US]; 2040 Dow Center, Midland, MI 48674 (US).
- (72) Inventors: **DEN DOELDER, Cornelis F. J.**; Kristaldreef  
6, NL-4533HD Terneuzen (NL). **KARJALA, Teresa P.**;  
56 Mandevilla Court, Lake Jackson, TX 77566 (US).  
**BERBEE, Otto J.**; Carmelweg 17, NL-4561XE Hulst  
(NL). **KARDOS, Lori L.**; 15 Sarahs Cove, Sugar Land,  
TX 77479 (US).
- (74) Agent: **TERRY, Jane**; The Dow Chemical Company, P.O.  
Box 1967, Midland, Michigan 48641-1967 (US).

(81) Designated States (unless otherwise indicated, for every kind of national protection available): AE, AG, AL, AM, AO, AT, AU, AZ, BA, BB, BG, BH, BN, BR, BW, BY, BZ, CA, CH, CL, CN, CO, CR, CU, CZ, DE, DK, DM, DO, DZ, EC, EE, EG, ES, FI, GB, GD, GE, GH, GM, GT, HN, HR, HU, ID, IL, IN, IR, IS, JP, KE, KG, KN, KP, KR, KZ, LA, LC, LK, LR, LS, LT, LU, LY, MA, MD, ME, MG, MK, MN, MW, MX, MY, MZ, NA, NG, NI, NO, NZ, OM, PA, PE, PG, PH, PL, PT, QA, RO, RS, RU, RW, SA, SC, SD, SE, SG, SK, SL, SM, ST, SV, SY, TH, TJ, TM, TN, TR, TT, TZ, UA, UG, US, UZ, VC, VN, ZA, ZM, ZW.

(84) Designated States (unless otherwise indicated, for every kind of regional protection available): ARIPO (BW, GH, GM, KE, LR, LS, MW, MZ, NA, RW, SD, SL, SZ, TZ, UG, ZM, ZW), Eurasian (AM, AZ, BY, KG, KZ, RU, TJ, TM), European (AL, AT, BE, BG, CH, CY, CZ, DE, DK, EE, ES, FI, FR, GB, GR, HR, HU, IE, IS, IT, LT, LU, LV, MC, MK, MT, NL, NO, PL, PT, RO, RS, SE, SI, SK, SM, TR), OAPI (BF, BJ, CF, CG, CI, CM, GA, GN, GQ, GW, KM, ML, MR, NE, SN, TD, TG).

**Published:**

— with international search report (Art. 21(3))



**WO 2014/190039 A1**

(54) Title: LOW DENSITY ETHYLENE-BASED COMPOSITIONS WITH IMPROVED MELT STRENGTH, OUTPUT, AND MECHANICAL PROPERTIES

(57) Abstract: The invention provides a composition comprising the following: A) a first ethylene-based polymer, formed by a high pressure, free-radical polymerization process, and comprising the following properties: a) a  $M_w(\text{abs})/M_w(\text{GPC}) < 2.2$ ; and b) a MS versus I2 relationship:  $MS \geq C \times [(I2)^D]$ , where  $C = 13.5 \text{ cN}/(\text{dg}/\text{min})^D$ , and  $D = -0.55$ , c) a melt index (I2) from 0.1 to 0.9 g/10 min; and B) a second ethylene-based polymer; and wherein the second ethylene-based polymer has a melt index (I2) from 0.1 to 4.0 g/10 min.

## LOW DENSITY ETHYLENE-BASED COMPOSITIONS WITH IMPROVED MELT STRENGTH, OUTPUT, AND MECHANICAL PROPERTIES

### REFERENCE TO RELATED APPLICATIONS

This application claims the benefit of U.S. Provisional Application 61/826,271, filed on May 22, 2013.

### BACKGROUND

Blown film production lines are typically limited in output by bubble stability. Blending Linear Low Density Polyethylene (LLDPE) with Low Density Polyethylene (LDPE) increases bubble stability, in part due to the higher melt strength of the LDPE. The increase in melt strength in part provides for an increase in film output. However, too high a melt strength, especially as with broad molecular weight distribution (MWD), autoclave LDPEs with fractional melt indexes, can cause gels, limiting drawdown capabilities, which can result in poor quality films. Also, high melt strength LDPE resins typically have reduced optics. Thus, there is a need for new compositions containing ethylene-based polymers, such as tubular LDPEs, that have an optimized balance of melt strength, optics and mechanical properties, for blown film applications.

Linear Low Density Polyethylene (LLDPE) is typically more difficult to process on a blown film line with generally poorer bubble stability, or lower maximum output (mass/time such as pounds per hour) than Low Density Polyethylene (LDPE). Films made with Linear Low Density Polyethylene (LLDPE), however, generally have better film mechanical properties than those made with Low Density Polyethylene (LDPE). Film processing and film properties are to a large extent optimized for blown films by blending Linear Low Density Polyethylene (LLDPE) with Low Density Polyethylene (LDPE). Blending in lower amounts of LDPE into LLDPE typically leads to improved processing compared to pure LLDPE, improved optical properties, and acceptable mechanical properties. Blending in high amounts of LDPE into LLDPE improves processing further and allows thick film of a very large bubble diameter to be produced, while the mechanical and optical film properties are maintained or improved over film made from pure LDPE. LDPE-rich films are also especially suited to shrink films, such as collation shrink films, where the LDPE imparts good shrinkage behavior which cannot be achieved by the use of a LLDPE alone. In summary, the LDPE blend component contributes typically to the processability, optical properties, and shrink performance, while the LLDPE blend component contributes to the mechanical

properties.

There is a need for new compositions that can increase the melt strength and the processing performance over conventional LDPE/LLDPE blends, and which can be made at low conversion costs in a tubular process. Furthermore, there is need for LDPE/LLDPE compositions with improved performance in processing (maximum line speed and or large bubble operation) and/or film properties (mechanical and shrink performance and/or optical appearance).

Low density polyethylenes and blends are disclosed in the following: U.S. Publication 2014/0094583; U.S. Patent 5,741,861; U.S. Patent 7,741,415; U.S. Patent 4,511,609; U.S. Patent 4,705,829; U.S. Publication No. 2008/0038533; JP61-241339 (Abstract); JP2005-232227 (Abstract); and International Publication Nos. WO2010/144784, WO2011/019563, WO 2010/042390, WO 2010/144784, WO 2011/019563, WO 2012/082393, WO 2006/049783, WO 2009/114661, US 2008/0125553, EP0792318A1 and EP 2239283B1. However, such polymers do not provide an optimized balance of high melt strength and improved film mechanical properties, for blown film applications. Thus, as discussed above, there remains a need for new ethylene-based polymer compositions that have an optimized balance of melt strength, optics, processability and output, and good shrinkage. These needs and others have been met by the following invention.

#### SUMMARY OF INVENTION

The invention provides a composition comprising the following:

A) a first ethylene-based polymer, formed by a high pressure, free-radical polymerization process, and comprising the following properties:

a) a  $M_w(\text{abs})/M_w(\text{GPC}) < 2.2$ ; and

b) a MS versus I2 relationship:  $MS \geq C \times [(I2)^D]$ , where  $C = 13.5 \text{ cN}/(\text{dg}/\text{min})^D$ , and  $D = -0.55$ ,

c) a melt index (I2) from 0.1 to 0.9 g/10 min; and

B) a second ethylene-based polymer; and

wherein the second ethylene-based polymer has a melt index (I2) from 0.1 to 4.0 g/10 min.

## BRIEF DESCRIPTION OF THE DRAWINGS

Figures 1A and 1B are schematics of a polymerization flow schemes. Figure 1A represents a general flow scheme. Figure 1B provides more detail of the discharge of the primary compressor system.

Figure 2 depicts the maximum output on the blown film line described herein versus the % LDPE in LLDPE1 used in the film.

Figure 3 depicts the MD shrink tension measured on a film made at standard rate versus the % LDPE in LLDPE1 used in the film.

Figure 4 depicts the melt strength measured on blends versus the % LDPE in LLDPE1.

## DETAILED DESCRIPTION

As discussed above, the invention provides a composition comprising the following:  
A) a first ethylene-based polymer, formed by a high pressure, free-radical polymerization process, and comprising the following properties:

- a) a  $M_w(\text{abs})/M_w(\text{GPC}) < 2.2$ ; and
- b) a MS versus I2 relationship:  $MS \geq C \times [(I2)^D]$ , where  $C = 13.5 \text{ cN}/(\text{dg}/\text{min})^D$ , and  $D = -0.55$ ,
- c) a melt index (I2) from 0.1 to 0.9 g/10 min; and

B) a second ethylene-based polymer; and

wherein the second ethylene-based polymer has a melt index (I2) from 0.1 to 4.0 g/10 min.

The composition may comprise a combination of two or more embodiments described herein.

In feature a) above, the  $M_w(\text{abs})$  and  $M_w(\text{GPC})$  are each determined by GPC Method A as described herein.

In feature b) above, the Melt Strength (MS) is determined at 190°C; see test method described herein.

In one embodiment, the composition has a density from 0.910 to 0.925 g/cc, further from 0.915 to 0.922 g/cc.

In one embodiment, the composition has a melt index (I2) from 0.1 to 1.5 g/10 min, further from 0.2 to 1.0 g/10 min, and further from 0.3 to 0.9 g/10 min.

In one embodiment, the composition has a Melt Strength (190°C) from 5 to 40 cN, further from 10 to 40 cN, further from 20 to 40 cN, further from 15 to 40 cN.

In one embodiment, when an inventive composition is formed into a film, via a blown film process, the maximum output rate is at least 15 percent greater than the maximum output rate of a similar film formed from a similar composition, except the composition contains 100 weight percent of the second ethylene-based polymer, based on the sum weight of the first ethylene-based polymer and the second ethylene-based polymer.

In one embodiment, the second ethylene-based polymer has a melt index (I2) from 0.2 to 3.5 g/10 min, further from 0.3 to 3.0 g/10 min, further from 0.4 to 2.5 g/10 min.

In one embodiment, the second ethylene-based has a density from 0.870 to 0.969 g/cc, further from 0.890 to 0.950 g/cc, further from 0.910 to 0.940 g/cc, further from 0.915 to 0.930 g/cc.

In one embodiment, the second ethylene-based polymer is present in an amount from 5 to 95 weight percent, further from 10 to 95 weight percent, further from 20 to 95 weight percent, further from 30 to 95 weight percent, based on weight of the composition.

In one embodiment, the second ethylene-based polymer is present in an amount from 40 to 95 weight percent, further from 50 to 95 weight percent, further from 60 to 95 weight percent, further from 70 to 95 weight percent, based on weight of the composition.

In one embodiment, the second ethylene-based polymer is an ethylene/ $\alpha$ -olefin interpolymers, and further a copolymer. In a further embodiment, the ethylene/ $\alpha$ -olefin interpolymers is a heterogeneously branched ethylene/ $\alpha$ -olefin interpolymers, and further a copolymer. Suitable  $\alpha$ -olefins include, but are not limited to, propylene, butene-1, pentene-1, 4-methylpentene-1, pentene-1, hexene-1 and octene-1, and preferably propylene, butene-1, hexene-1 and octene-1.

In one embodiment, the second ethylene-based polymer is selected from an ethylene/ $\alpha$ -olefin copolymer, a low density polyethylene (LDPE), a high density polyethylene (HDPE), or a combination thereof.

The second ethylene-based polymer may comprise a combination of two or more embodiments as described herein.

In one embodiment, the first ethylene-based polymer is present in an amount from "greater than zero" to 30 weight percent, further from 1 to 25 weight percent, further from 2 to 20 weight percent, based on the sum of the weight of first ethylene-based polymer and the second ethylene-based polymer.

In one embodiment, the first ethylene-based polymer is present in an amount greater than, or equal to, 20 weight percent, further greater than, or equal to, 50 weight percent, based on the sum of the weight of first ethylene-based polymer and the second ethylene-based

polymer.

In one embodiment, the first ethylene-based polymer is present in an amount from 1 to 95 weight percent, further from 5 to 95 weight percent, further from 10 to 90 weight percent, based on the sum of the weight of first ethylene-based polymer and the second ethylene-based polymer.

In one embodiment, the first ethylene-based polymer has a melt index (I2) from 0.2 g/10 min to 0.9 g/10 min, further from 0.3 g/10 min to 0.9 g/10 min (ASTM 2.16 kg/190°C).

In one embodiment, the first ethylene-based polymer has b) a Mw(abs) versus I2 relationship:  $Mw(abs) < A \times [(I2)^B]$ , where  $A = 5.00 \times 10^2$  (kg/mole)/(dg/min)<sup>B</sup>, and  $B = -0.40$  (Mw(abs) by GPC method A).

In one embodiment, the first ethylene-based polymer has b) a Mw(abs) versus I2 relationship:  $Mw(abs) < A \times [(I2)^B]$ , where  $A = 4.25 \times 10^2$  (kg/mole)/(dg/min)<sup>B</sup>, and  $B = -0.40$  (Mw(abs) by GPC method A).

In one embodiment, the first ethylene-based polymer has a c) a MS versus I2 relationship:  $MS \geq C \times [(I2)^D]$ , where  $C = 14.5$  cN/ (dg/min)<sup>D</sup>, and  $D = -0.55$  (Melt Strength = MS, 190°C).

In one embodiment, the first ethylene-based polymer has a c) a MS versus I2 relationship:  $MS \geq C \times [(I2)^D]$ , where  $C = 15.5$  cN/ (dg/min)<sup>D</sup>, and  $D = -0.55$  (Melt Strength = MS, 190°C).

In one embodiment, the first ethylene-based polymer has a melt strength greater than, or equal to, 9.0 cN, at 190°C, further greater than, or equal to, 12.0 cN, at 190°C, further greater than, or equal to, 15.0 cN, at 190°C.

In one embodiment, the first ethylene-based polymer has a Melt Strength (190°C) from 10 to 40 cN, further from 15 to 30 cN.

In one embodiment, the first ethylene-based polymer has a “weight fraction (w) of molecular weight greater than  $10^6$  g/mole, based on the total weight of polymer, as determined by GPC(abs), that meets the following relationship:  $w < E \times [(I2)^F]$ , where  $E = 0.110$  (dg/min)<sup>-F</sup>, and  $F = -0.38$  (GPC Method A).

In one embodiment, the first ethylene-based polymer is polymerized in at least one tubular reactor. In a further embodiment, the first ethylene-based polymer is polymerized in a tubular reactor system that does not comprise an autoclave reactor.

In one embodiment, the first ethylene-based polymer is selected from a polyethylene homopolymer or an ethylene-based interpolymer.

In one embodiment, in the first ethylene-based polymer is selected from a

polyethylene homopolymer or an ethylene-based copolymer; and wherein the comonomer of the ethylene-based copolymer is selected from a vinyl acetate, an alkyl acrylate, carbon monoxide, an acrylic acid, a carboxylic acid-containing comonomer, an ionomer, a mono olefin, or selected from a vinyl acetate, an alkyl acrylate, acrylic acid, or a mono olefin. In a further embodiment, the comonomer is present in an amount from 0.5 to 30 wt% comonomer, based on weight of copolymer.

In one embodiment, the first ethylene-based polymer is a LDPE.

In one embodiment, the first ethylene-based polymer has a density from 0.910 to 0.940 g/cc (1 cc = 1 cm<sup>3</sup>).

In one embodiment, the first ethylene-based polymer has a density greater than, or equal to, 0.912 g/cc, or greater than, or equal to, 0.915 g/cc, or greater than, or equal to, 0.916 g/cc.

In one embodiment, the first ethylene-based polymer has a density less than, or equal to, 0.935 g/cc, or less than, or equal to, 0.930 g/cc, or less than, or equal to, 0.925 g/cc, or less than, or equal to, 0.920 g/cc.

The first ethylene-based polymer may comprise a combination of two or more embodiments as described herein.

An inventive composition may comprise a combination of two or more embodiments as described herein.

The invention also provides an article comprising at least one component formed from an inventive composition.

In one embodiment, the article is selected from coatings, films, foams, laminates, fibers, or tapes. In another embodiment, the article is a film.

The invention also provides a film comprising at least one layer formed from an inventive composition.

In one embodiment, the film comprises at least two layers.

In one embodiment, the film has a MD shrink tension greater than 3.00 psi.

An inventive article may comprise a combination of two or more embodiments as described herein.

An inventive film may comprise a combination of two or more embodiments as described herein

#### *Polymerizations*

For a high pressure, free radical initiated polymerization process, two basic types of reactors are known. The first type is an agitated autoclave vessel having one or more reaction

zones (the autoclave reactor). The second type is a jacketed tube which has one or more reaction zones (the tubular reactor). The pressure in each autoclave and tubular reactor zone of the process is typically from 100 to 400, more typically from 120 to 360, and even more typically from 150 to 320 MPa. The polymerization temperature in each tubular reactor zone of the process is typically from 100 to 400°C, more typically from 130 to 360°C, and even more typically from 140 to 330°C.

The polymerization temperature in each autoclave reactor zone of the process is typically from 150 to 300°C, more typically from 165 to 290°C, and even more typically from 180 to 280°C.

The high pressure process of the present invention to produce polyethylene homo or interpolymers, having the advantageous properties, as found in accordance with the invention, is preferably carried out in a tubular reactor having at least three reaction zones.

The first ethylene-based polymers with broad MWD are typically made at polymerization conditions comprising one or more of the following process elements:

- Reduced operating pressure (versus maximum operating pressure of reactor system).
- Elevated polymerization temperatures: one or more autoclave zone and/or one or more tubular reactor zone are operated at a control or maximum peak temperature exceeding respectively 240 and 290°C.
- Minimal three reaction zones of autoclave and/or tubular nature.
- Selection of type and/or distribution of CTA over the reaction zones to ensure broad MWD product.
- Optional use of a bifunctional coupling and/or branching agent.

#### *Initiators*

The first ethylene-based polymer is formed by a free radical polymerization process. The type of free radical initiator to be used in the present process is not critical, but preferably one of the initiators applied should allow high temperature operation in the range from 300°C to 350°C. Free radical initiators that are generally used include organic peroxides, such as peresters, perketals, peroxy ketones, percarbonates, and cyclic multifunctional peroxides. These organic peroxy initiators are used in conventional amounts, typically from 0.005 to 0.2 wt% based on the weight of polymerizable monomers. Other suitable initiators include azodicarboxylic esters, azodicarboxylic dinitriles and 1,1,2,2-tetramethylethane derivatives, and other components capable of forming free radicals in the desired operating temperature range. Peroxides are typically injected as diluted solutions in a suitable solvent, for example, in a hydrocarbon solvent.

In one embodiment, an initiator is added to at least one reaction zone of the polymerization, and wherein the initiator has a “half-life temperature at one second” greater than 255°C, preferably greater than 260°C. In a further embodiment, such initiators are used at a peak polymerization temperature from 320°C to 350°C. In a further embodiment, the initiator comprises at least one peroxide group incorporated in a ring structure.

Examples of such initiators include, but are not limited to, TRIGONOX 301 (3,6,9-triethyl-3,6,9-trimethyl-1,4,7-triperoxonane) and TRIGONOX 311 (3,3,5,7,7-pentamethyl-1,2,4-trioxepane), both available from Akzo Nobel, and HMCH-4-AL (3,3,6,6,9,9-hexamethyl-1,2,4,5-tetroxonane) available from United Initiators. See also International Publication Nos. WO 02/14379 and WO 01/68723.

#### *Chain Transfer Agents (CTA)*

Chain transfer agents or telogens are used to control the melt index in a polymerization process. Chain transfer involves the termination of growing polymer chains, thus limiting the ultimate molecular weight of the polymer material. Chain transfer agents are typically hydrogen atom donors that will react with a growing polymer chain and stop the polymerization reaction of the chain. These agents can be of many different types, from saturated hydrocarbons or unsaturated hydrocarbons to aldehydes, ketones or alcohols. By controlling the concentration of the selected chain transfer agent, one can control the length of polymer chains, and, hence the molecular weight, for example, the number average molecular weight,  $M_n$ . The melt flow index (MFI or  $I_2$ ) of a polymer, which is related to  $M_n$ , is controlled in the same way.

The chain transfer agents used in the process of this invention include, but are not limited to, aliphatic and olefinic hydrocarbons, such as pentane, hexane, cyclohexane, propene, pentene or hexene; ketones such as acetone, diethyl ketone or diamyl ketone; aldehydes such as formaldehyde or acetaldehyde; and saturated aliphatic aldehyde alcohols such as methanol, ethanol, propanol or butanol. The chain transfer agent may also be a monomeric chain transfer agent. For example, see WO 2012/057975, US 61/579067, and US 61/664956.

Differentiated CTA concentrations in the reaction zones can be used to achieve and to control the desired molecular weight distribution. Means to differentiate the CTA concentration in reaction zones include among others methods described in WO2013/059042, WO2011/075465 and WO2012/044504.

A further way to influence the melt index includes the build up and control, in the ethylene recycle streams, of incoming ethylene impurities, like methane and ethane, peroxide

dissociation products, like tert-butanol, acetone, etc., and or solvent components used to dilute the initiators. These ethylene impurities, peroxide dissociation products, and/or dilution solvent components can act as chain transfer agents.

#### *Monomer and Comonomers*

The term ethylene interpolymer as used in the present description and the claims refer to polymers of ethylene and one or more comonomers. Suitable comonomers to be used in the ethylene polymers of the present invention include, but are not limited to, ethylenically unsaturated monomers and especially C<sub>3-20</sub> alpha-olefins, carbon monoxide, vinyl acetate, alkyl acrylates, or a bifunctional or higher functional comonomer (includes monomers with two or more monomeric groups). Typically comonomers can also act as chain transfer agents to some degree. Those comonomers with high chain transfer activity are designated as monomeric CTAs.

#### *Additives*

An inventive composition may comprise one or more additives. Suitable additives include stabilizers; fillers, such as organic or inorganic particles, including clays, talc, titanium dioxide, zeolites, powdered metals, organic or inorganic fibers, including carbon fibers, silicon nitride fibers, steel wire or mesh, and nylon or polyester cording, nano-sized particles, clays, and so forth; tackifiers, oil extenders, including paraffinic or naphthenic oils. An inventive composition may comprise other polymer types.

#### *Applications*

The polymers of this invention may be employed in a variety of conventional thermoplastic fabrication processes to produce useful articles, including, but not limited to, monolayer and multilayer films; molded articles, such as blow molded, injection molded, or rotomolded articles; coatings; fibers; and woven or non-woven fabrics.

An inventive polymer may be used in a variety of films, including but not limited to, extrusion coating, food packaging, consumer, industrial, agricultural (applications or films), lamination films, fresh cut produce films, meat films, cheese films, candy films, clarity shrink films, collation shrink films, stretch films, silage films, greenhouse films, fumigation films, liner films, stretch hood, heavy duty shipping sacks, pet food, sandwich bags, sealants, and diaper backsheets.

An inventive polymer is also useful in other direct end-use applications. An inventive polymer may be used for wire and cable coating operations, in sheet extrusion for vacuum forming operations, and forming molded articles, including the use of injection molding, blow molding process, or rotomolding processes.

Other suitable applications for the inventive polymers include elastic films and fibers; soft touch goods, such as appliance handles; gaskets and profiles; auto interior parts and profiles; foam goods (both open and closed cell); impact modifiers for other thermoplastic polymers, such as high density polyethylene, or other olefin polymers; cap liners; and flooring.

## DEFINITIONS

Unless stated to the contrary, implicit from the context, or customary in the art, all parts and percents are based on weight and all test methods are current as of the filing date of this disclosure.

The term "composition," as used herein, refers to a mixture of materials which comprise the composition, as well as reaction products and decomposition products formed from the materials of the composition.

The terms "blend" or "polymer blend," as used, mean an intimate physical mixture (that is, without reaction) of two or more polymers. A blend may or may not be miscible (not phase separated at molecular level). A blend may or may not be phase separated. A blend may or may not contain one or more domain configurations, as determined from transmission electron spectroscopy, light scattering, x-ray scattering, and other methods known in the art. The blend may be effected by physically mixing the two or more polymers on the macro level (for example, melt blending resins or compounding) or the micro level (for example, simultaneous forming within the same reactor, or forming one polymer in the presence of another polymer).

The term "polymer" refers to a compound prepared by polymerizing monomers, whether of the same or a different type. The generic term polymer thus embraces the term homopolymer (which refers to polymers prepared from only one type of monomer with the understanding that trace amounts of impurities can be incorporated into the polymer structure), and the term "interpolymer" as defined *infra*. Trace amounts of impurities may be incorporated into and/or within a polymer.

The term "interpolymer" refers to polymers prepared by the polymerization of at least two different types of monomers. The generic term interpolymer includes copolymers (which refers to polymers prepared from two different monomers), and polymers prepared from more than two different types of monomers.

The term "ethylene-based polymer" or "ethylene polymer" refers to a polymer that comprises a majority amount of polymerized ethylene based on the weight of the polymer,

and, optionally, may comprise at least one comonomer.

The term “ethylene-based interpolymer” or “ethylene interpolymer” refers to an interpolymer that comprises a majority amount of polymerized ethylene based on the weight of the interpolymer, and comprises at least one comonomer.

The term “ethylene-based copolymer” or “ethylene copolymer” refers to an interpolymer that comprises a majority amount of polymerized ethylene based on the weight of the copolymer, and only one comonomer (thus, only two monomer types).

The terms “autoclave-based products” or “autoclaved-based polymers,” as used herein, refer to polymers prepared in a reactor system comprising at least one autoclave reactor.

The phrase “high pressure, free-radical polymerization process,” as used herein, refers to a free radical initiated polymerization carried out at an elevated pressure of at least 1000 bar (100 MPa).

The terms “comprising,” “including,” “having,” and their derivatives, are not intended to exclude the presence of any additional component, step or procedure, whether or not the same is specifically disclosed. In order to avoid any doubt, all compositions claimed through use of the term “comprising” may include any additional additive, adjuvant, or compound, whether polymeric or otherwise, unless stated to the contrary. In contrast, the term, “consisting essentially of” excludes from the scope of any succeeding recitation any other component, step or procedure, excepting those that are not essential to operability. The term “consisting of” excludes any component, step or procedure not specifically delineated or listed.

## TEST METHODS

**Density:** Samples for density measurement are prepared according to ASTM D 1928. Polymer samples are pressed at 190°C and 30,000 psi (207 MPa) for three minutes, and then at 21°C and 207 MPa for one minute. Measurements are made within one hour of sample pressing using ASTM D792, Method B.

**Melt Index:** Melt index, or  $I_2 = I_2$ , (grams/10 minutes or dg/min) is measured in accordance with ASTM D 1238, Condition 190°C/2.16 kg.  $I_{10}$  is measured with ASTM D 1238, Condition 190°C/10 kg.

**Method A: Triple Detector Gel Permeation Chromatography (TDGPC):** High temperature 3Det-GPC analysis is performed on an ALLIANCE GPCV2000 instrument (Waters Corp.) set at 145°C. The flow rate for the GPC is 1 mL/min. The injection volume

is 218.5  $\mu\text{L}$ . The column set consists of four Mixed-A columns (20- $\mu\text{m}$  particles; 7.5  $\times$  300 mm; Polymer Laboratories Ltd).

Detection is achieved by using an IR4 detector from PolymerChAR, equipped with a CH-sensor; a Wyatt Technology Dawn DSP MALS detector (Wyatt Technology Corp., Santa Barbara, CA, USA), equipped with a 30-mW argon-ion laser operating at  $\lambda = 488 \text{ nm}$ ; and a Waters three-capillary viscosity detector. The MALS detector is calibrated by measuring the scattering intensity of the TCB solvent. Normalization of the photodiodes is done by injecting SRM 1483, a high density polyethylene with weight-average molecular weight (Mw) of 32,100 g/mol and polydispersity (MWD) of 1.11. A specific refractive index increment ( $dn/dc$ ) of -0.104 mL/mg, for polyethylene in TCB, is used.

The conventional GPC calibration is done with 20 narrow PS standards (Polymer Laboratories Ltd.) with molecular weights in the range 580–7,500,000 g/mol. The polystyrene standard peak molecular weights are converted to polyethylene molecular weights using the following equation:

$$M_{\text{polyethylene}} = A \times (M_{\text{polystyrene}})^B,$$

with  $A = 0.39$ ,  $B = 1$ . The value of A is determined by using a linear high density polyethylene homopolymer (HDPE) with Mw of 115,000 g/mol. The HDPE reference material is also used to calibrate the IR detector and viscometer by assuming 100 % mass recovery and an intrinsic viscosity of 1.873 dL/g.

The column calibration curve was obtained by fitting a first order polynomial to the respective polyethylene-equivalent calibration points obtained from the above Equation to the observed elution volumes.

Number, weight, and z-average molecular weights (GPC) were calculated according to the following equations:

$$\overline{Mn} = \frac{\sum_i w_{f_i}}{\sum_i \left( \frac{w_{f_i}}{M_i} \right)} \quad \overline{Mw} = \frac{\sum_i (w_{f_i} * M_i)}{\sum_i w_{f_i}} \quad \overline{Mz} = \frac{\sum_i (w_{f_i} * M_i^2)}{\sum_i (w_{f_i} * M_i)},$$

where,  $w_{f_i}$  is the weight fraction of the  $i$ -th component and  $M_i$  is the molecular weight of the  $i$ -th component. The molecular weight distribution (MWD) was expressed as the ratio of the weight average molecular weight (Mw) to the number average molecular weight (Mn).

Distilled “Baker Analyzed” grade 1,2,4-trichlorobenzene (J.T. Baker, Deventer, The Netherlands), containing 200 ppm of 2,6-di-tert-butyl-4-methylphenol (Merck, Hohenbrunn, Germany), is used as the solvent for sample preparation, as well as for the 3Det-GPC experiment. HDPE SRM 1483 is obtained from the U.S. National Institute of Standards and

Technology (Gaithersburg, MD, USA).

LDPE solutions are prepared by dissolving the samples under gentle stirring for three hours at 160°C. The PS standards are dissolved under the same conditions for 30 minutes. The sample concentration for the 3Det-GPC experiment is 1.5 mg/mL, and the polystyrene concentrations are 0.2 mg/mL.

A MALS detector measures the scattered signal from polymers or particles in a sample under different scattering angles  $\theta$ . The basic light scattering equation (from M. Anderson, B. Wittgren, K.-G. Wahlund, *Anal. Chem.* 75, 4279 (2003)) can be written as follows:

$$\sqrt{\frac{Kc}{R_{\theta}}} = \sqrt{\frac{1}{M} + \frac{16\pi^2}{3\lambda^2} \frac{1}{M} R_g^2 \sin^2\left(\frac{\theta}{2}\right)},$$

where  $R_{\theta}$  is the excess Rayleigh ratio,  $K$  is an optical constant, which is, among other things, dependent on the specific refractive index increment ( $dn/dc$ ),  $c$  is the concentration of the solute,  $M$  is the molecular weight,  $R_g$  is the radius of gyration, and  $\lambda$  is the wavelength of the incident light. Calculation of the molecular weight and radius of gyration from the light scattering data require extrapolation to zero angle (see also P.J. Wyatt, *Anal. Chim. Acta* 272, 1 (1993)). This is done by plotting  $(Kc/R_{\theta})^{1/2}$  as a function of  $\sin^2(\theta/2)$  in the so-called Debye plot. The molecular weight can be calculated from the intercept with the ordinate, and the radius of gyration from the initial slope of the curve. The second virial coefficient is assumed to be negligible. The intrinsic viscosity numbers are calculated from both the viscosity and concentration detector signals by taking the ratio of the specific viscosity and the concentration at each elution slice.

ASTRA 4.72 (Wyatt Technology Corp.) software is used to collect the signals from the IR detector, the viscometer, and the MALS detector, and to run the calculations.

The calculated molecular weights, e.g.  $M_w(\text{abs})$ , and molecular weight distributions (e.g.,  $M_w(\text{abs})/M_n(\text{abs})$ ) are obtained using a light scattering constant derived from one or more of the polyethylene standards mentioned and a refractive index concentration coefficient,  $dn/dc$ , of 0.104. Generally, the mass detector response and the light scattering constant should be determined from a linear standard with a molecular weight in excess of about 50,000 Daltons. The viscometer calibration can be accomplished using the methods described by the manufacturer, or alternatively, by using the published values of suitable linear standards such as Standard Reference Materials (SRM) 1475a, 1482a, 1483, or 1484a. The chromatographic concentrations are assumed low enough to eliminate addressing 2<sup>nd</sup>

virial coefficient effects (concentration effects on molecular weight).

The obtained MWD(abs) curve from TD-GPC is summarized with three characteristic parameters:  $M_w(\text{abs})$ ,  $M_n(\text{abs})$ , and  $w$ , where  $w$  is defined as “weight fraction of molecular weight greater than  $10^6$  g/mole, based on the total weight of polymer, and as determined by GPC(abs).”

In equation form, the parameters are determined as follows. Numerical integration from the table of “logM” and “dw/dlogM” is typically done with the trapezoidal rule:

$$M_w(\text{abs}) = \int_{-\infty}^{\infty} M \frac{dw}{d\log M} d\log M,$$

$$M_n(\text{abs}) = \frac{1}{\int_{-\infty}^{\infty} \frac{1}{M} \frac{dw}{d\log M} d\log M}, \text{ and}$$

$$w = \int_6^{\infty} \frac{dw}{d\log M} d\log M.$$

### **Method B: Triple Detector Gel Permeation Chromatography (TDGPC) – Conventional GPC Data**

A Triple Detector Gel Permeation Chromatography (3D-GPC or TDGPC) system consisting of a Polymer Laboratories (now Agilent) high temperature chromatograph Model 220, equipped with a 2-angle laser light scattering (LS) detector Model 2040 (Precision Detectors, now Agilent), an IR-4 infra-red detector from Polymer Char (Valencia, Spain), and a 4-capillary solution viscometer (DP) (Viscotek, now Malvern) was used. Data collection was performed using Polymer Char DM 100 data acquisition box and related software (Valencia, Spain). The system was also equipped with an on-line solvent degassing device from Polymer Laboratories (now Agilent).

High temperature GPC columns consisting of four 30 cm, 20  $\mu\text{m}$  mixed A LS columns from Polymer Laboratories (now Agilent) were used. The sample carousel compartment was operated at  $140^\circ\text{C}$ , and the column compartment was operated at  $150^\circ\text{C}$ . The samples were prepared at a concentration of 0.1 grams of polymer in 50 milliliters of solvent. The chromatographic solvent and the sample preparation solvent was 1,2,4-trichlorobenzene (TCB) containing 200 ppm of 2,6-di-tert-butyl-4methylphenol (BHT). The solvent was sparged with nitrogen. The polymer samples were gently stirred at  $160^\circ\text{C}$  for four hours. The injection volume was 200 microliters. The flow rate through the GPC was set at 1.0 ml/minute.

Column calibration and sample molecular weight calculations were performed using Polymer Char “GPC One” software. Calibration of the GPC columns was performed with 21 narrow molecular weight distribution polystyrene standards. The molecular weights of the

polystyrene standards ranged from 580 to 8,400,000 g/mol, and were arranged in 6 “cocktail” mixtures, with at least a decade of separation between the individual molecular weights.

The peak molecular weights of polystyrene standards were converted to polyethylene molecular weights using the following equation (as described in Williams and Ward, J. Polym. Sci., Polym. Let., 6, 621 (1968)):

$$M_{polyethylene} = A(M_{polystyrene})^B,$$

here B has a value of 1.0, and the experimentally determined value of A is around 0.38 to 0.44.

The column calibration curve was obtained by fitting a first order polynomial to the respective polyethylene-equivalent calibration points obtained from the above Equation to the observed elution volumes.

Number, weight, and z-average molecular weights were calculated according to the following equations:

$$\overline{Mn} = \frac{\sum_i w f_i}{\sum_i \left( \frac{w f_i}{M_i} \right)} \quad \overline{Mw} = \frac{\sum_i (w f_i * M_i)}{\sum_i w f_i} \quad \overline{Mz} = \frac{\sum_i (w f_i * M_i^2)}{\sum_i (w f_i * M_i)}$$

Where,  $w f_i$  is the weight fraction of the  $i$ -th component and  $M_i$  is the molecular weight of the  $i$ -th component. The molecular weight distribution (MWD) was expressed as the ratio of the weight average molecular weight (Mw) to the number average molecular weight (Mn).

The A value was determined by adjusting the A value in the Williams and Ward Equation until Mw, the weight average molecular weight calculated using the above Equation, and the corresponding retention volume polynomial agreed with the independently determined value of Mw obtained in accordance with the linear homopolymer reference with known weight average molecular weight of 115,000 g/mol.

### **Melt Strength**

Melt strength measurements are conducted on a Gottfert Rheotens 71.97 (Göettfert Inc.; Rock Hill, SC) attached to a Gottfert Rheotester 2000 capillary rheometer. A polymer melt is extruded through a capillary die with a flat entrance angle (180 degrees) with a capillary diameter of 2.0 mm and an aspect ratio (capillary length/capillary diameter) of 15.

After equilibrating the samples at 190°C for 10 minutes, the piston is run at a constant piston speed of 0.265 mm/second. The standard test temperature is 190°C. The sample is drawn uniaxially to a set of accelerating nips located 100 mm below the die with an acceleration of 2.4 mm/second<sup>2</sup>. The tensile force is recorded as a function of the take-up speed of the nip rolls. Melt strength is reported as the plateau force (cN) before the strand

broke. The following conditions are used in the melt strength measurements: plunger speed = 0.265 mm/second; wheel acceleration = 2.4 mm/s<sup>2</sup>; capillary diameter = 2.0 mm; capillary length = 30 mm; and barrel diameter = 12 mm.

### **Nuclear Magnetic Resonance (<sup>13</sup>C NMR)**

Samples were prepared by adding approximately “3 g of a 50/50 mixture of tetrachloroethane-d<sub>2</sub>/orthodichlorobenzene, containing 0.025 M Cr(AcAc)<sub>3</sub>,” to a “0.25 to 0.40 g polymer sample,” in a 10 mm NMR tube. Oxygen was removed from the sample by placing the open tubes in a nitrogen environment for at least 45 minutes. The samples were then dissolved and homogenized by heating the tube, and its contents to 150°C, using a heating block and heat gun. Each dissolved sample was visually inspected to ensure homogeneity. Samples were thoroughly mixed, immediately prior to analysis, and were not allowed to cool before insertion into the heated NMR sample holders.

All data were collected using a Bruker 400 MHz spectrometer. The data was acquired using a six second pulse repetition delay, 90-degree flip angles, and inverse gated decoupling, with a sample temperature of 125°C. All measurements were made on non-spinning samples in locked mode. Samples were allowed to thermally equilibrate for seven minutes prior to data acquisition. The <sup>13</sup>C NMR chemical shifts were internally referenced to the EEE triad at 30.0 ppm. The C6+ value was a direct measure of C6+ branches in LDPE, where the long branches were not distinguished from chain ends. The 32.2 ppm peak, representing the third carbon from the end of all chains or branches of six or more carbons, was used to determine C6+ value.

### **Nuclear Magnetic Resonance (<sup>1</sup>H NMR)**

#### *Sample Preparation*

The samples were prepared by adding approximately 130 mg of sample to “3.25 g of 50/50, by weight, tetrachlorethane-d<sub>2</sub>/perchloroethylene” with 0.001 M Cr(AcAc)<sub>3</sub> in a NORELL 1001-7, 10 mm NMR tube. The samples were purged by bubbling N<sub>2</sub> through the solvent, via a pipette inserted into the tube, for approximately five minutes, to prevent oxidation. Each tube was capped, sealed with TEFLON tape, and then soaked at room temperature, overnight, to facilitate sample dissolution. The samples were kept in a N<sub>2</sub> purge box, during storage, before, and after preparation, to minimize exposure to O<sub>2</sub>. The samples were heated and vortexed at 115°C to ensure homogeneity.

#### *Data Acquisition Parameters*

The <sup>1</sup>H NMR was performed on a Bruker AVANCE 400 MHz spectrometer, equipped with a Bruker Dual DUL high-temperature CryoProbe, and a sample temperature of

120°C. Two experiments were run to obtain spectra, a control spectrum to quantitate the total polymer protons, and a double presaturation experiment, which suppressed the intense polymer backbone peaks, and enabled high sensitivity spectra for quantitation of the end-groups. The control was run with ZG pulse, 4 scans, SWH 10,000 Hz, AQ 1.64s, D1 14s. The double presaturation experiment was run with a modified pulse sequence, TD 32768, 100 scans, DS 4, SWH 10,000 Hz, AQ 1.64s, D1 1s, D13 13s.

#### *Data Analysis- <sup>1</sup>H NMR Calculations*

The signal from residual 1H in TCE-d2 (at 6.0 ppm) was integrated, and set to a value of 100, and the integral from 3 to -0.5 ppm was used as the signal from the whole polymer in the control experiment. For the presaturation experiment, the TCE signal was also set to 100, and the corresponding integrals for unsaturation (vinylene at about 5.40 to 5.60 ppm, trisubstituted at about 5.16 to 5.35 ppm, vinyl at about 4.95 to 5.15 ppm, and vinylidene at about 4.70 to 4.90 ppm) were obtained.

In the presaturation experiment spectrum, the regions for cis- and trans-vinylene, trisubstituted, vinyl, and vinylidene were integrated. The integral of the whole polymer from the control experiment was divided by two to obtain a value representing X thousands of carbons (i.e., if the polymer integral = 28000, this represents 14,000 carbons, and X=14).

The unsaturated group integrals, divided by the corresponding number of protons contributing to that integral, represent the moles of each type of unsaturation per X thousand carbons. Dividing the moles of each type of unsaturation by X, then gives moles unsaturated groups per 1000 moles of carbons.

#### **Film Testing**

The following physical properties were measured on the films as described in the experimental section. Film thickness was measured using a Measuretech instrument.

Total (Overall) Haze and Internal Haze: Internal haze and total haze were measured according to ASTM D 1003-07. Internal haze was obtained via refractive index matching using mineral oil (1-2 teaspoons), which was applied as a coating on each surface of the film. A Hazegard Plus (BYK-Gardner USA; Columbia, MD) was used for testing. For each test, five samples were examined, and an average reported. Sample dimensions were “6 in x 6 in.”

45° Gloss: ASTM D2457-08 (average of five film samples; each sample “10 in x 10 in”).

Clarity: ASTM D1746-09 (average of five film samples; each sample “10 in x 10 in”).

2% Secant Modulus- MD (machine direction) and CD (cross direction): ASTM D882-10 (average of five film samples in each direction; each sample “1 in x 6 in”).

MD and CD Elmendorf Tear Strength: ASTM D1922-09 (average of 15 film samples in each direction; each sample “3 in x 2.5 in” half moon shape).

MD and CD Tensile Strength: ASTM D882-10 (average of five film samples in each direction; each sample “1 in x 6 in”).

Dart Impact Strength: ASTM D1709-09 (minimum of 20 drops to achieve a 50% failure; typically ten “10 in x 36 in” strips).

Puncture Strength: Puncture was measured on an INSTRON Model 4201 with SINTECH TESTWORKS SOFTWARE Version 3.10. The specimen size was “6 in x 6 in,” and four measurements were made to determine an average puncture value. The film was conditioned for 40 hours after film production, and at least 24 hours in an ASTM controlled laboratory (23°C and 50% relative humidity). A “100 lb” load cell was used with a round specimen holder of 4 inch diameter. The puncture probe is a “½ inch diameter” polished stainless steel ball (on a 2.5” rod) with a “7.5 inch maximum travel length.”

There was no gauge length, and the probe was as close as possible to, but not touching, the specimen. The probe was set by raising the probe until it touched the specimen. Then the probe was gradually lowered, until it was not touching the specimen. Then the crosshead was set at zero. Considering the maximum travel distance, the distance would be approximately 0.10 inch. The crosshead speed was 10 inches/minute. The thickness was measured in the middle of the specimen. The thickness of the film, the distance the crosshead traveled, and the peak load were used to determine the puncture by the software. The puncture probe was cleaned using a “KIM-WIPE” after each specimen.

Shrink Tension: Shrink tension was measured according to the method described in Y. Jin, T. Hermel-Davidock, T. Karjala, M. Demirors, J. Wang, E. Leyva, and D. Allen, “Shrink Force Measurement of Low Shrink Force Films”, SPE ANTEC Proceedings, p. 1264 (2008). The shrink tension of film samples was measured through a temperature ramp test that was conducted on an RSA-III Dynamic Mechanical Analyzer (TA Instruments; New Castle, DE) with a film fixture. Film specimens of “12.7 mm wide” and “63.5 mm long” were die cut from the film sample, either in the machine direction (MD) or the cross direction (CD), for testing. The film thickness was measured by a Mitutoyo Absolute digimatic indicator (Model C112CEXB). This indicator had a maximum measurement range of 12.7 mm, with a resolution of 0.001 mm. The average of three thickness measurements, at different locations on each film specimen, and the width of the specimen, were used to

calculate the film's cross sectional area ( $A$ ), in which " $A = \text{Width} \times \text{Thickness}$ " of the film specimen that was used in shrink film testing. A standard film tension fixture from TA Instruments was used for the measurement. The oven of the RSA-III was equilibrated at 25°C, for at least 30 minutes, prior to zeroing the gap and the axial force. The initial gap was set to 20 mm.

The film specimen was then attached onto both the upper and the lower fixtures. Typically, measurements for MD only require one ply film. Because the shrink tension in the CD direction is typically low, two or four plies of films are stacked together for each measurement to improve the signal-to-noise ratio. In such a case, the film thickness is the sum of all of the plies. In this work, a single ply was used in the MD direction and two plies were used in the CD direction. After the film reached the initial temperature of 25°C, the upper fixture was manually raised or lowered slightly to obtain an axial force of -1.0 g. This was to ensure that no buckling or excessive stretching of the film occurred at the beginning of the test. Then the test was started. A constant fixture gap was maintained during the entire measurement.

The temperature ramp started at a rate of 90°C/min, from 25°C to 80°C, followed by a rate of 20°C/min, from 80°C to 160°C. During the ramp from 80°C to 160°C, as the film shrunk, the shrink force, measured by the force transducer, was recorded as a function of temperature for further analysis. The difference between the "peak force" and the "baseline value before the onset of the shrink force peak" is considered the shrink force ( $F$ ) of the film. The shrink tension of the film is the ratio of the shrink force ( $F$ ) to the initial cross sectional area ( $A$ ) of the film.

For the MD Shrink Tension, three film samples were tested, and an average reported.

For the CD Shrink Tension, three film samples were tested, and an average reported.

## **EXPERIMENTAL**

### **First Ethylene-based Polymer**

**IEI:** The polymerization was carried out in tubular reactor with three reaction zones. In each reaction zone, pressurized water was used for cooling and/or heating the reaction medium, by circulating this water through the jacket of the reactor. The inlet-pressure was 2100 bar, and the pressure drop over the whole tubular reactor system was about 300 bars. Each reaction zone had one inlet and one outlet. Each inlet stream consisted of the outlet stream from the previous reaction zone and/or an added ethylene-rich feed stream. The ethylene was supplied according to a specification, which allowed a trace amount (maximum

of 5 mol ppm) of acetylene in the ethylene. The non-converted ethylene, and other gaseous components in the reactor outlet, were recycled through a high pressure and a low pressure recycle system, and were compressed and distributed through a booster, a primary compressor system and a hyper (secondary) compressor system, according to the flow scheme shown in Figure 1B. As seen in Figure 1B, both discharge streams (2 and 3) of the primary compressor were sent to the reactor front feed stream 5.

Organic peroxides were fed into each reaction zone (see Table 1). Propionaldehyde was used as a chain transfer agent, and it was present in each reaction zone inlet originating from the low pressure and high pressure recycle flows (13 and 15), as well as from freshly injected CTA make-up stream 7 and/or stream 6. The polymer was made at a melt index of 0.58 g/10 min.

After reaching the first peak temperature (maximum temperature) in reaction zone 1, the reaction medium was cooled with the help of the pressurized water. At the outlet of the reaction zone 1, the reaction medium was further cooled by injecting a fresh, cold, ethylene-rich feed stream (20), and the reaction was re-initiated by feeding an organic peroxide. This process was repeated at the end of the second reaction zone, to enable further polymerization in the third reaction zone. The polymer was extruded and pelletized (about 30 pellets per gram), using a "single screw" extruder system at a melt temperature around 230-250°C. The weight ratio of the ethylene-rich feed streams (9:20:21) to the three reaction zones was 1.00:0.76:0.24. The R2 and R3 values each approached infinity. The R values are calculated according to International Publication WO 2013/059042 (International Patent Application PCT/US12/059469 filed October 10, 2012).  $R_n$  ( $n =$  reaction zone number,  $n > 1$ ) is the ratio of "mass fraction of fresh ethylene fed to the first reaction zone (RZ1)" to "mass fraction of fresh ethylene fed to the nth reaction zone (RZn)" is ( $R_n = RZ1/RZn$ ). The internal process velocity was approximately 12.5, 9 and 11 m/sec, respectively, for the first, second and third reaction zone. In this inventive example, the weight ratio of the CTA make-up streams 7 and 6 was 2. Additional information can be found in Tables 2 and 3.

#### *Example IE2*

The polymerization was carried out in tubular reactor with three reaction zones, as discussed above, according to Example IE1 (see Figure 1B). The weight ratio of the ethylene-rich feed streams (9:20:21) to the three reaction zones was 1.00:0.76:0.24. The polymer was made at a melt index of 0.37 g/10 min. The R2 and R3 values each approached infinity ( $\infty$ ). In this inventive example, the weight ratio of the CTA make-up streams 7 and 6 was 1.35. Additional information can be found in Tables 2 and 3. The CTA was

propionaldehyde (PA).

In summary, to achieve tubular resins with high melt strength suitable as blend component in extrusion coating compositions, typically together with a low or lower melt strength component, the polymerization conditions need to be selected and balanced; for example, as discussed above. Important process parameters include maximum polymerization temperatures, inlet reactor pressure, conversion level, and the type, level and distribution of the chain transfer agent.

Polymer properties (IE1, IE2 and other polymers) are shown in Tables 4 and 5.

Table 1: Initiators

Initiator	Abbreviation
tert-Butyl peroxy-2-ethyl hexanoate	TBPO
Di-tert-butyl peroxide	DTBP
3,6,9-triethyl 3,6,9-trimethyl 1,4,7-peroxonane	TETMP

Table 2: Pressure and Temperature Conditions (First Ethylene-based Polymers)

LDPE Exs.	Type	Inlet-pressure / bar	Start-temp. /°C	reinitiation temp. 2nd zone /°C	reinitiation temp. 3rd zone /°C	1st Peak temp. / °C	2nd Peak temp./°C	3rd Peak temp. /°C
IE1	Inv	2100	140	169	243	330	325	299
IE2	Inv	2100	140	173	243	327	323	299

Table 3: Additional Information (First Ethylene-based Polymers)

LDPE Exs.	Peroxides	CTA	I2 dg/min <sup>-1</sup>	R2 and R3 Value	Ethylene Conversion %
IE1	TBPO/DTBP/TEIMP	PA	0.58	∞	29.3
IE2	TBPO/DTBP/TEIMP	PA	0.37	∞	27.6

Table 4: Polymer Properties

LDPE	Type*	I2 (dg/min)	Density (g/cc)	Mw(abs) (kg/mol) <sup>†</sup>	Mw(abs)/M n(abs) <sup>†</sup>	Melt Strength (cN)	Fraction with MW above 1x10 <sup>6</sup> g/mol <sup>†</sup>	Mw(abs)/ Mw(GPC) <sup>†</sup>
LDPE 662I**	CE, AC	0.38	0.9182	872	46.1	30.0	0.202	3.54
LD310E**	CE, tub	0.7	0.9231	144	8.3	14.0	0.018	1.51
AGILITY 1001**	CE, tub	0.64	0.9206	204	15.6	11.3	0.032	1.81
LDPE 132I**	CE, tub	0.25	0.9209	273	15.3	17.3	0.052	2.14
IE1	IE, tub	0.58	0.9180	287	16.6	26.8	0.066	1.92
IE2	IE, tub	0.37	0.9180	297	17.5	29.9	0.072	2.01

\*CE: Comparative; IE: Inventive; AC: Autoclave-based; tub: Tubular. \*\*Commercial Polymers available from The Dow Chemical Company.

†: All MWD metrics in this table obtained from GPC Method A.

Table 5: Polymer Properties

LDPE	I2 (dg/min)	Mw(abs) (kg/mol) <sup>†</sup>	Melt Strength (cN)	Fraction with M above 1.10 <sup>6</sup> g/mol <sup>†</sup>	A x [(I2) <sup>B</sup> ] (kg/mol) <sup>a</sup>	C x [(I2) <sup>D</sup> ] (cN) <sup>b</sup>
662I	0.38	872	30.0	0.202	736	23.0
LD310E	0.7	144	14.0	0.018	577	16.4
AGILITY 1001	0.64	204	11.3	0.032	613	17.9
LDPE 132I	0.25	273	17.3	0.052	871	28.9
IE1	0.58	287	26.8	0.066	622	18.2
IE2	0.37	297	29.9	0.072	744	23.3

a)  $Mw(ABS) < A \times [(I2)^B]$ , where  $A = 5.00 \times 10^2$  (kg/mole)/(dg/min)<sup>B</sup>, and  $B = -0.40$  [Mw(abs), GPC Method A]. b)  $MS \geq C \times [(I2)^D]$ , where  $C = 13.5$  cN/(dg/min)<sup>D</sup>, and  $D = -0.55$  [Melt Strength = MS, 190°C]. †: All MWD metrics in this table obtained from GPC Method A.

Table 6 contains the branches per 1000C as measured by  $^{13}\text{C}$  NMR. These LDPE polymers contain amyl, or C5 branches, which are not contained in substantially linear polyethylenes such as AFFINITY Polyolefin Plastomers, or Ziegler-Natta catalyzed LLDPE, such as DOWLEX Polyethylene Resins, both produced by The Dow Chemical Company. Each LDPE shown in Table 6 contains greater than, or equal to, 2.0 amyl groups (branches) per 1000 carbon atoms. Table 7 contains unsaturation results by  $^1\text{H}$  NMR.

Table 6: Branching Results in branches per 1000C by  $^{13}\text{C}$  NMR of Inventive Examples and Comparative Examples.

	C1	1,3 diethyl branches	C2 on Quat Carbon	C4	C5	C6+
IE1	ND	4.51	1.82	7.26	2.63	3.8
IE2	ND	4.55	1.83	7.30	2.16	3.5
AFFINITY PL 1880	ND	ND	ND	ND	ND	19.5*
DOWLEX 2045G	ND	ND	ND	ND	ND	11.4*

ND = not detected.

\* The values in the C6+ column for the DOWLEX and AFFINITY samples represent C6 branches from octene only, and do not include chain ends.

Table 7: Unsaturation Results by  $^1\text{H}$  NMR

	vinyl / 1000C	cis and trans / 1000C	trisub / 1000C	vinylidene / 1000C	total unsaturation / 1000C
IE1	0.046	0.148	0.083	0.247	0.52
IE2	0.048	0.137	0.075	0.246	0.51
AFFINITY PL 1880	0.040	0.064	0.123	0.043	0.270
DOWLEX 2045G	0.283	0.049	0.042	0.055	0.430

## Formulations

Blown films were made, and physical properties measured, with different LDPEs and one LLDPE, LLDPE1 (DOWLEX 2045G). LLDPE1 had a 1.0 melt index (MI or I2), and a 0.920 g/cc density. Films were made at 5 wt%, 10 wt%, 20 wt%, 50 wt% and 80 wt% of the respective LDPE, based on the weight of the LDPE and LLDPE1.

Each formulation was compounded on a MAGUIRE gravimetric blender. A polymer processing aid (PPA), DYNAMAR FX-5920A, was added to each formulation. The PPA was added at 1 wt% of masterbatch, based on the total weight of the weight of the formulation. The PPA masterbatch (Ingenia AC-01-01, available from Ingenia Polymers) contained 8 wt% of DYNAMAR FX-5920A in a polyethylene carrier. This amounts to 800 ppm PPA in the polymer.

LLDPE1 was also used as the LLDPE in the films made at maximum output. Maximum output was determined on samples made with the following components: 95 wt%

DOWLEX 2045G and 5 wt% LDPE; 90 wt% DOWLEX 2045G and 10 wt% LDPE; and 80 wt% DOWLEX 2045G and 20 wt% LDPE.

### Production of Blown Films

The monolayer blown films were made on an “8 inch die” with a polyethylene “Davis Standard Barrier II screw.” External cooling by an air ring and internal bubble cooling were used. General blown film parameters, used to produce each blown film, are shown in Table 8. The temperatures are the temperatures closest to the pellet hopper (Barrel 1), and in increasing order, as the polymer was extruded through the die. The films at the standard rates were run at 250 lb/hr.

Table 8: Blown film fabrication conditions for films.

Blow up ratio (BUR)	2.5
Nominal Film thickness	2.0
Die gap (mil)	70
Air temperature (°F)	45
Temperature profile (°F)	
Barrel 1	375
Barrel 2	420
Barrel 3	390
Barrel 4	375
Barrel 5	375
Screen Temperature	450
Adapter	450
Block	450
Lower Die	450
Inner Die	450
Upper Die	450

### *Production of Films for Determination of Maximum Output Rate of Blown Film*

Film samples were made at a controlled rate and at a maximum rate. The controlled rate was 250 lb/hr, which equals a specific output rate of 10.0 lb/hr/inch of die circumference. The die diameter used for the maximum output trials was an 8 inch die, so that for the controlled rate, as an example, the conversion between “lb/hr” and “lb/hr/inch” of die circumference, is shown below. Similarly, such an equation can be used for other rates, such as the maximum rate, by substituting the maximum rate in the equation below to determine the “lb/hr/inch” of die circumference.

$$\text{Specific Output} = (250 \text{ Lb/Hr}) / (8 \text{ inch} * \pi) = 10 \text{ Lb/Hr/Inch of Die Circumference}$$

The maximum output rate for a given sample was determined by increasing the output rate to the point where bubble stability was the limiting factor. The extruder profile was maintained for both samples (standard rate and maximum rate), however the melt temperature was higher for the maximum rate samples, due to the increased shear rate with

higher motor speed (rpm, revolutions per minute). The bubble stability at maximum output rate was determined by taking the bubble to the point where it would not stay seated in the air ring. At that point, the rate was reduced to where the bubble was reseated (maximum output rate) in the air ring, and then a sample was collected. The cooling on the bubble was adjusted by adjusting the air ring and maintaining the bubble. This process determined the maximum output rate while maintaining bubble stability.

The film results are summarized in Tables 9-16. Table 9 shows film results at standard rate with Film #1 being 100% LLDPE1, and Films #2-6 being 95% LLDPE1/5% LDPE. Film #2, containing IE1 and Film #3 containing IE2, show advantages of good optics (low haze, and high gloss and clarity), MD tear (high), dart drop impact (high), and secant modulus (high). These properties are important for a variety of films with the desirable properties of good optics and mechanical properties. These LDPEs enable the potential for down-gauging, or lowering of the film thickness, while still retaining good mechanical properties. Table 10 shows film results at maximum rate with Film #7 being 100% LLDPE1, and Films #8-12 being 95% LLDPE1/5% LDPE. These films show advantages, as seen in Table 9 at standard rate. Additionally, compositions containing IE1 and IE2 show improvement in film output rates from 0.5 – 3.2% over compositions containing the other LDPEs even at this low level of 5 wt% addition. The % increase in maximum output, as shown in Table 10, was calculated as, for example for IE1:

$$\% \text{ Increase in Output Due to IE1 as Compared to Reference LDPE} = \frac{(\text{Maximum Output Blend with IE1} - \text{Maximum Output Blend with Reference LDPE})}{\text{Maximum Output Blend with Reference LDPE}} \times 100.$$

Table 11 contains results for 10% LDPE added to LLDPE1 for Films #13-17, and Table 12 contains results for 10% LDPE added to LLDPE1 for Films #18-22, made at maximum rate. These results show films advantages similar to those seen at 5% LDPE (good optics, MD tear, dart drop impact, and secant modulus). Additionally, the maximum rate increases over the reference LDPEs range up to 8.4%, as shown in Table 12.

Table 13 shows results for 80% LLDPE/20% LDPE at standard rates, and Table 14 shows results for 20% LDPE/80% LLDPE1 at maximum rates. These results show properties similar to the lower %LDPE blends, but additionally, at maximum rates, good shrink tension is found for the inventive compositions. The maximum output rates as compared to other LDPEs are excellent at up to a 44% improvement. Although the autoclave LDPE 662I does have good output rates, it suffers from poorer optics and puncture. These very substantial differences in output are novel for the inventive compositions, and will translate, on larger

blown film lines, to likely even more differentiation and larger gains in the speed at which blown films can be produced, leading to cost savings for the producer. Additionally, key film property advantages are maintained.

Table 15 and 16 show results at 50% LDPE and 80% LDPE, respectively. Maximum output was not measured on these samples, but it is expected that the output of IE1 and IE2 would be very good and generally better than the comparative examples. Again, the optics, as compared to the autoclave LDPE 662I, are much improved, with retention of other film properties.

Figure 2 shows the maximum output for the different LDPEs in LLDPE1, at 0%, 5%, 10%, and 20% LDPE, and the differentiation and advantage of IE1 and IE2, as compared to other LDPEs. Figure 3 shows the MD shrink tension for films made at standard output for the different LDPEs in LLDPE1, at 0%, 5%, 10%, and 20% LDPE, and the differentiation and advantage of IE1 and IE2 as compared to other LDPEs.

Table 9: Film properties of 100% LLDPE1; and 95% LLDPE1/5% LDPE Films #1 – 6 made at 2 mil at a standard (std.) rate of 250 lb/hr (8” die).

Film	1	2	3	4	5	6
Component 1 (First Polymer)	-	IE1	IE2	AGILITY 1001	LDPE 662I	LDPE 132I
Wt% Component 1	0	5	5	5	5	5
Melt Index Component 1	-	0.58	0.37	0.64	0.38	0.25
Component 2 (Second Polymer)	LLDPE1	LLDPE1	LLDPE1	LLDPE1	LLDPE1	LLDPE1
Wt% Component 2	100	95	95	95	95	95
Blown Film Rate	Std.	Std.	Std.	Std.	Std.	Std.
Haze (%)	16.8	11.1	10.6	9.8	10.4	9.4
Haze, Internal (%)	5.9	4.3	4.0	4.4	4.6	4.0
45 Degree Gloss (%)	48.8	61.3	61.6	68.2	64.1	67.4
Clarity (%)	97.3	98.0	97.2	99.0	96.1	99.0
MD Tear (g)	874	822	809	735	774	797
CD Tear (g)	934	957	1,027	975	1,008	1,023
Normalized MD Tear (g/mil)	454	422	404	379	378	392
Normalized CD Tear (g/mil)	489	484	517	504	493	500
Dart Drop Impact (g)	388	343	322	334	283	302
Puncture (ft-lbf/in <sup>3</sup> )	278	269	254	264	271	275
2% MD Secant Modulus (kpsi)	37.7	38.5	38.8	35.6	36.9	36.7
2% CD Secant Modulus (kpsi)	42.5	42.6	42.8	40.2	41.7	39.7
MD Shrink Tension (psi)	3.29	5.50	4.70	6.04	4.46	5.99
CD Shrink Tension (psi)	0.43	0.43	0.70	0.54	0.60	0.70
Thickness (mil)	1.96	2.05	2.06	1.83	1.97	2.01
Frost Line Height (inches)	40	35	35	35	35	35
Melt Temperature (°F)	443	440	440	439	439	440
Rate Output (lb/hr)	253	251	247	251	247	250
Rate Output (lb/hr/in)	10.1	10.0	9.8	10.0	9.8	9.9
Screen Pressure (psi)	3,550	3,630	3,590	3,620	3,590	3,610

Table 10: Film properties of 100% LLDPE1; and 95% LLDPE1/5% LDPE Films #7 – 12 made at 2 mil at maximum rates (8” die).

Film	7	8	9	10	11	12
Component 1 (First Polymer)	-	IE1	IE2	AGILITY 1001	LDPE 662I	LDPE 132I
Wt% Component 1	0	5	5	5	5	5
Melt Index Component 1	-	0.58	0.37	0.64	0.38	0.25
Component 2 (Second Polymer)	LLDPE1	LLDPE1	LLDPE1	LLDPE1	LLDPE1	LLDPE1
Wt% Component 2	100	95	95	95	95	95
Haze (%)	29.5	17.6	14.9	13.2	15.2	14.6
Internal Haze (%)	5.7	4.6	4.8	4.8	5.9	6.0
45 Degree Gloss (%)	27.1	40.4	49.4	54.1	46.9	50.9
Clarity (%)	92.7	96.9	96.8	98.4	96.1	98.2
MD Tear (g)	975	834	711	830	891	820
CD Tear (g)	1,089	1,051	917	981	1,135	1,148
Normalized MD Tear (g/mil)	442	401	380	422	407	373
Normalized CD Tear (g/mil)	503	509	492	497	524	526
Dart Drop Impact (g)	379	352	313	334	322	319
Puncture (ft-lbf/in <sup>3</sup> )	281	274	255	286	271	257
2% MD Secant Modulus (kpsi)	37.2	39.5	39.8	33.8	34.8	39.1
2% CD Secant Modulus (kpsi)	45.0	41.8	44.8	39.3	43.5	41.6
MD Shrink Tension (psi)	1.48	3.15	5.32	4.19	4.04	3.70
CD Shrink Tension (psi)	0.29	0.49	0.50	0.42	0.43	0.44
Thickness (mil)	1.89	1.93	2.07	2.04	2.06	2.16
Frost Line Height (inches)	70	75	75	75	75	75
Melt Temperature (°F)	451	457	458	457	457	456
Rate Output (lb/hr)	329	380	387	378	375	376
Rate Output (lb/hr/in)	13.1	15.1	15.4	15.0	14.9	15.0
% Increase of Maximum Rate IE1 over given LDPE				0.5	1.3	1.1
% Increase of Maximum Rate IE2 over given LDPE				2.4	3.2	2.9
% Increase of Maximum Rate over LLDPE1		16	18	15	14	14
Screen Pressure (psi)	4,150	4,290	4,420	4,400	4,290	4,420

Table 11: Film properties of 90% LLDPE1/10% LDPE Films #13 – 17 made at 2 mil at a standard (std.) rate of 250 lb/hr (8" die).

Film	13	14	15	16	17
Component 1 (First Polymer)	IE1	IE2	AGILITY 1001	LDPE 662I	LDPE 132I
Wt% Component 1	10	10	10	10	10
Melt Index Component 1	0.58	0.37	0.64	0.38	0.25
Component 2 (Second Polymer)	LLDPE1	LLDPE1	LLDPE1	LLDPE1	LLDPE1
Wt% Component 2	90	90	90	90	90
Blown Film Rate	Std.	Std.	Std.	Std.	Std.
Haze (%)	9.2	9.7	8.7	10.6	8.3
Haze, Internal (%)	3.5	3.3	4.0	4.0	3.4
45 Degree Gloss (%)	66.9	63.2	68.9	59.7	68.4
Clarity (%)	97.4	95.7	98.9	93.0	98.6
MD Tear (g)	639	575	580	542	590
CD Tear (g)	993	1,081	1,058	1,035	1,077
Normalized MD Tear (g/mil)	316	287	296	276	295
Normalized CD Tear (g/mil)	488	543	539	515	545
Dart Drop Impact (g)	337	313	301	274	250
Puncture (ft-lbf/in <sup>3</sup> )	249	267	244	261	266
2% MD Secant Modulus (kpsi)	37.7	36.7	30.2	30.1	29.2
2% CD Secant Modulus (kpsi)	42.3	41.3	33.6	36.2	34.0
MD Shrink Tension (psi)	6.08	7.42	5.66	5.91	5.42
CD Shrink Tension (psi)	0.36	0.64	0.51	0.63	0.26
Thickness (mil)	2.02	2.05	1.89	2.00	1.97
Frost Line Height (inches)	35	35	35	35	35
Melt Temperature (°F)	440	439	441	439	440
Rate Output (lb/hr)	251	250	250	252	248
Rate Output (lb/hr/in)	10.0	9.9	9.9	10.0	9.9
Screen Pressure (psi)	3,620	3,740	3,540	3,740	3,660

Table 12: Film properties of 90% LLDPE1/10% LDPE Films #18 – 22 made at 2 mil at maximum rates (8" die).

Film	18	19	20	21	22
Component 1 (First Polymer)	IE1	IE2	AGILITY 1001	LDPE 662I	LDPE 132I
Wt% Component 1	10	10	10	10	10
Melt Index Component 1	0.58	0.37	0.64	0.38	0.25
Component 2 (Second Polymer)	LLDPE1	LLDPE1	LLDPE1	LLDPE1	LLDPE1
Wt% Component 2	90	90	90	90	90
Haze (%)	13.5	12.7	10.6	13.1	12.2
Internal Haze (%)	3.8	3.9	4.7	4.4	4.0
45 Degree Gloss (%)	49.6	50.1	61.7	53.3	54.3
Clarity (%)	96.8	96.1	98.3	94.0	98.2
MD Tear (g)	720	666	628	588	673
CD Tear (g)	1,086	1,145	1,103	1,045	1,092
Normalized MD Tear (g/mil)	358	317	309	298	338
Normalized CD Tear (g/mil)	549	551	550	524	545
Dart Drop Impact (g)	304	313	274	259	277
Puncture (ft-lbf/in <sup>3</sup> )	255	235	221	245	251
2% MD Secant Modulus (kpsi)	36.9	33.0	32.2	37.7	33.0
2% CD Secant Modulus (kpsi)	45.1	38.4	35.6	31.3	38.6
MD Shrink Tension (psi)	6.03	5.73	5.72	5.02	5.25
CD Shrink Tension (psi)	0.52	0.76	0.32	0.23	0.50
Thickness (mil)	2.03	1.82	1.83	1.98	1.86
Frost Line Height (inches)	84	85	80	80	80
Melt Temperature (°F)	458	461	459	460	461
Rate Output (lb/hr)	402	415	383	403	392
Rate Output (lb/hr/in)	16.0	16.5	15.2	16.0	15.6
% Increase of Maximum Rate IE1 over given LDPE			5.0	-0.2	2.6
% Increase of Maximum Rate IE2 over given LDPE			8.4	3.0	5.9
% Increase of Maximum Rate over LLDPE1	22	26	16	22	19
Screen Pressure (psi)	4,480	4,600	4,270	4,450	4,390

Table 13: Film properties of 80% LLDPE1/20% LDPE Films #23 – 27 made at 2 mil at a standard (std.) rate of 250 lb/hr (8" die).

Film	23	24	25	26	27
Component 1 (First Polymer)	IE1	IE2	AGILITY 1001	LDPE 662I	LDPE 132I
Wt% Component 1	20	20	20	20	20
Melt Index Component 1	0.58	0.37	0.64	0.38	0.25
Component 2 (Second Polymer)	LLDPE1	LLDPE1	LLDPE1	LLDPE1	LLDPE1
Wt% Component 2	80	80	80	80	80
Blown Film Rate	Std.	Std.	Std.	Std.	Std.
Haze (%)	9.3	12.8	7.2	15.3	8.2
Haze, Internal (%)	2.9	3.3	3.3	2.7	2.6
45 Degree Gloss (%)	61.5	48.9	72.6	44.4	65.4
Clarity (%)	92.9	85.6	98.3	82.3	96.2
MD Tear (g)	400	357	429	408	396
CD Tear (g)	1,060	1,065	1,225	1,006	1,186
Normalized MD Tear (g/mil)	200	182	216	208	201
Normalized CD Tear (g/mil)	525	540	611	509	593
Dart Drop Impact (g)	214	226	220	244	241
Puncture (ft-lbf/in <sup>3</sup> )	212	224	236	209	222
2% MD Secant Modulus (kpsi)	30.9	30.2	29.6	29.7	30.8
2% CD Secant Modulus (kpsi)	35.6	35.7	32.8	37.2	36.4
MD Shrink Tension (psi)	11.32	12.66	9.29	7.05	11.53
CD Shrink Tension (psi)	0.49	0.34	0.59	0.41	0.65
Thickness (mil)	1.99	1.95	2.08	1.96	2.02
Frost Line Height (inches)	35	35	35	35	35
Melt Temperature (°F)	439	440	441	441	440
Rate Output (lb/hr)	252	252	251	251	250
Rate Output (lb/hr/in)	10.0	10.0	10.0	10.0	9.9
Screen Pressure (psi)	3,660	3,650	3,580	3,730	3,720

Table 14: Film properties of 80% LLDPE1/20% LDPE Films #28 – 32 made at 2 mil at maximum rates (8" die).

Film	28	29	30	31	32
	IE1	IE2	AGILITY 1001	LDPE 662I	LDPE 132I
Component 1 (First Polymer)					
Wt% Component 1	20	20	20	20	20
Melt Index Component 1	0.58	0.37	0.64	0.38	0.25
Component 2 (Second Polymer)	LLDPE1	LLDPE1	LLDPE1	LLDPE1	LLDPE1
Wt% Component 2	80	80	80	80	80
Haze (%)	10.5	14.1	12.0	15.5	11.6
Internal Haze (%)	3.2	3.3	4.8	3.4	3.5
45 Degree Gloss (%)	56.3	44.7	54.9	40.9	55.7
Clarity (%)	93.5	88.1	98.0	83.4	96.6
MD Tear (g)	430	445	508	420	489
CD Tear (g)	1,105	1,031	991	1,015	1,185
Normalized MD Tear (g/mil)	216	228	249	218	236
Normalized CD Tear (g/mil)	555	514	492	505	576
Dart Drop Impact (g)	244	238	238	244	280
Puncture (ft-lbf/in <sup>3</sup> )	216	216	216	198	224
2% MD Secant Modulus (kpsi)	30.9	28.0	30.9	29.9	32.7
2% CD Secant Modulus (kpsi)	34.8	34.6	35.9	36.2	37.3
MD Shrink Tension (psi)	10.33	10.97	7.05	12.33	8.21
CD Shrink Tension (psi)	0.42	0.46	0.41	0.46	0.38
Thickness (mil)	2.04	2.01	2.10	1.96	2.05
Frost Line Height (inches)	85	85	85	85	85
Melt Temperature (°F)	475	480	457	482	464
Rate Output (lb/hr)	541	581	405	577	443
Rate Output (lb/hr/in)	21.5	23.1	16.1	23.0	17.6
% Increase of Maximum Rate IE1 over given LDPE			33.6	-0.6	22.1
% Increase of Maximum Rate IE2 over given LDPE			43.5	0.3	31.2
% Increase of Maximum Rate over LLDPE1	64	77	23	76	35
Screen Pressure (psi)	4,990	5,160	4,310	5,200	4,610

Table 15: Film properties of 50% LLDPE1/50% LDPE Films #33 – 37 made at 2 mil at a standard (std.) rate of 250 lb/hr (8" die).

Film	33	34	35	36	37
	IE1	IE2	AGILITY 1001	LDPE 662I	LDPE 132I
Component 1 (First Polymer)					
Wt% Component 1	50	50	50	50	50
Melt Index Component 1	0.58	0.37	0.64	0.38	0.25
Component 2	LLDPE1	LLDPE1	LLDPE1	LLDPE1	LLDPE1
Wt% Component 2	50	50	50	50	50
Blown Film Rate	Std.	Std.	Std.	Std.	Std.
Haze (%)	18.9	23.9	9.5	31.9	13.0
Haze, Internal (%)	3.1	2.1	2.3	2.0	1.7
45 Degree Gloss (%)	34.5	28.0	58.0	24.3	47.8
Clarity (%)	70.0	61.8	90.3	79.0	84.3
MD Tear (g)	159	129	188	170	146
CD Tear (g)	1,088	1,024	981	933	1,022
Normalized MD Tear (g/mil)	80	65	98	89	75
Normalized CD Tear (g/mil)	550	514	501	478	525
Dart Drop Impact (g)	181	157	169	181	190
Puncture (ft-lbf/in <sup>3</sup> )	112	113	128	128	122
2% MD Secant Modulus (kpsi)	31.5	33.9	29.6	30.4	32.7
2% CD Secant Modulus (kpsi)	37.2	39.2	35.0	36.6	37.0
MD Shrink Tension (psi)	27.42	28.64	22.40	27.69	26.08
CD Shrink Tension (psi)	0.38	0.31	0.36	0.34	0.53
Thickness (mil)	2.03	2.06	1.97	1.96	2.00
Frost Line Height (inches)	30	30	30	35	30
Melt Temperature (°F)	442	442	440	443	444
Rate Output (lb/hr)	247	251	249	250	250
Rate Output (lb/hr/in)	9.8	10.0	9.9	9.9	9.9
Screen Pressure (psi)	3,350	3,650	3,280	3,680	3,600

Table 16: Film properties of 20% LLDPE1/80% LDPE Films #38 – 42 made at 2 mil at a standard (std.) rate of 250 lb/hr (8" die).

Film	38	39	40	41	42
Component 1 (First Polymer)	IE1	IE2	AGILITY 1001	LDPE 662I	LDPE 132I
Wt% Component 1	80	80	80	80	80
Melt Index Component 2	0.58	0.37	0.64	0.38	0.25
Component 2 (Second Polymer)	LLDPE1	LLDPE1	LLDPE1	LLDPE1	LLDPE1
Wt% Component 2	20	20	20	20	20
Blown Film Rate	Std.	Std.	Std.	Std.	Std.
Haze (%)	19.4	25.3	9.8	38.8	13.5
Haze, Internal (%)	1.6	2.4	2.5	2.3	1.6
45 Degree Gloss (%)	32.4	23.9	55.7	16.5	43.0
Clarity (%)	69.7	60.7	88.9	44.2	83.3
MD Tear (g)	201	159	246	135	224
CD Tear (g)	340	336	369	317	377
Normalized MD Tear (g/mil)	103	81	126	67	114
Normalized CD Tear (g/mil)	174	171	188	159	192
Dart Drop Impact (g)	169	145	163	154	172
Puncture (ft-lbf/in <sup>3</sup> )	63	59	80	66	85
2% MD Secant Modulus (kpsi)	32.4	33.7	31.2	32.2	33.7
2% CD Secant Modulus (kpsi)	38.2	38.9	35.2	37.7	34.9
MD Shrink Tension (psi)	35.80	42.34	24.91	41.80	32.65
CD Shrink Tension (psi)	0.58	0.81	0.47	0.37	0.52
Thickness (mil)	1.93	1.90	2.10	2.01	1.86
Frost Line Height (inches)	35	35	35	35	35
Melt Temperature (°F)	437	439	435	441	442
Rate Output (lb/hr)	250	250	251	252	251
Rate Output (lb/hr/in)	9.9	9.9	10.0	10.0	10.0
Screen Pressure (psi)	2,830	3,000	2,790	3,100	3,230

### Blend Compositions

Blends of the same compositions used for the blown films were made for further characterization. The blend components were compounded using an “18 mm” twin screw extruder (micro-18). The twin screw extruder used was a Leistritz machine controlled by Haake software. The extruder had five heated zones, a feed zone, and a “3 mm” strand die. The feed zone was cooled by flowing water, while the remaining zones 1-5 and the die were electrically heated and air cooled to 120, 135, 150, 190, 190, and 190°C, respectively. The pelletized polymer components were combined in a plastic bag, and tumble blended by hand. After preheating the extruder, the load cell and die pressure transducers were calibrated. The drive unit for the extruder was run at 200 rpm, which resulted by gear transfer to a screw speed of 250 rpm. The dry blend was then fed (6–8 lbs/hr) to the extruder through a twin auger K-Tron feeder (model # K2VT20) using pellet augers. The hopper of the feeder was padded with nitrogen, and the feed cone to the extruder was covered with foil, to minimize air

intrusion to minimize possible oxygen degradation of the polymer. The resulting strand was water quenched, dried with an air knife, and pelletized with a Conair chopper.

Results are shown in Table 17 for compositions similar to those shown in Tables 9-16, along with measured melt index, melt index ratio, density, and Mw, Mw/Mn, and Mz. The melt strength data are plotted in Figure 4 showing the differentiation and advantage of IE1 and IE2 as compared to all other LDPEs. IE2 shows similar behavior to autoclave LDPE 662I, but without the disadvantages of poor optics and gels that can result in a film made autoclave resins.

Table 17: Properties of blend compositions with Component 2 being LLDPE 1 (wt% component 1 + component 2 = 100 wt%). All MWD metrics in this table obtained from GPC Method B.

Component 1 (First Polymer)	Wt% Component 1	Blend Melt Index I2 (dg/min)	Blend Melt Index I10/I2	Blend Density (g/cm <sup>3</sup> )	Blend Melt Strength (cN)	Mw (Conv.) (g/mole)	Mw/Mn (Conv.)	Mz (Conv.) (g/mole)
NA	NA	0.95	7.82	0.9195	3.0	116,405	4.48	424,790
NA	NA	0.92	7.92	0.9197	3.3	112,802	4.28	359,035
IE1	5	0.87	8.04	0.9200	7.7	115,378	4.58	375,719
IE2	5	0.85	8.20	0.9200	8.3	114,457	4.41	355,947
AGILITY 1001	5	0.85	8.35	0.9202	8.1	112,877	4.68	367,415
LDPE 662I	5	0.83	8.12	0.9199	8.6	119,170	4.56	403,479
LDPE 132I	5	0.83	8.30	0.9200	6.9	113,560	4.51	371,408
IE1	10	0.80	8.33	0.9200	11.3	116,727	4.81	377,182
IE2	10	0.76	8.46	0.9202	12.9	117,557	4.63	380,858
AGILITY 1001	10	0.82	8.52	0.9203	8.4	111,535	4.54	347,557
LDPE 662I	10	0.80	8.24	0.9204	12.1	122,082	4.69	417,770
LDPE 132I	10	0.74	8.63	0.9208	10.4	113,259	4.58	373,270
IE1	20	0.66	9.26	0.9200	18.1	118,923	5.29	396,338
IE2	20	0.64	9.39	0.9202	19.4	121,298	5.21	396,353
AGILITY 1001	20	0.72	9.15	0.9202	12.8	110,725	4.61	349,287
LDPE 662I	20	0.65	8.92	0.9200	18.8	134,284	5.07	481,163
LDPE 132I	20	0.60	9.72	0.9206	15.0	113,934	4.85	378,039
IE1	50	0.51	12.12	0.9198	30.1	129,948	6.64	424,669
IE2	50	0.43	12.53	0.9197	32.2	136,584	7.09	457,937
AGILITY 1001	50	0.55	11.76	0.9208	20.6	108,229	5.32	338,591
LDPE 662I	50	0.42	11.57	0.9192	32.7	171,553	6.89	629,965
LDPE 132I	50	0.37	12.27	0.9210	24.3	113,796	5.35	364,709
IE1	80	0.45	15.98	0.9191	28.9	140,692	8.19	468,772
IE2	80	0.34	16.79	0.9193	29.4	151,185	9.06	513,576
AGILITY 1001	80	0.48	15.66	0.9204	23.0	104,630	5.89	328,746
LDPE 662I	80	0.39	14.42	0.9192	29.1	205,602	9.00	742,661
LDPE 132I	80	0.27	16.67	0.9209	25.0	138,463	6.87	503,623

## CLAIMS

1. A composition comprising the following:
  - A) a first ethylene-based polymer, formed by a high pressure, free-radical polymerization process, and comprising the following properties:
    - a) a  $M_w(\text{abs})/M_w(\text{GPC}) < 2.2$ , and
    - b) a MS versus I2 relationship:  $MS \geq C \times [(I2)^D]$ , where  $C = 13.5 \text{ cN}/(\text{dg}/\text{min})^D$ , and  $D = -0.55$ ,
    - c) a melt index (I2) from 0.1 to 0.9 g/10 min; and
  - B) a second ethylene-based polymer; andwherein the second ethylene-based polymer has a melt index (I2) from 0.1 to 4.0 g/10 min.
2. The composition of claim 1, wherein the first ethylene-based polymer is present in an amount greater than 0.5 weight percent, based on the sum of the weight of first ethylene-based polymer and the second ethylene-based polymer.
3. The composition of any one of the previous claims, wherein the second ethylene-based polymer present in an amount from 10 to 95 wt%, based on weight of the composition.
4. The composition of any one of the previous claims, wherein the second ethylene-based polymer is an ethylene/ $\alpha$ -olefin interpolymer.
5. The composition of claim 4, wherein the ethylene/ $\alpha$ -olefin interpolymer is a heterogeneously branched ethylene/ $\alpha$ -olefin interpolymer.
6. The composition of any one of the previous claims, wherein the composition has a Melt Strength (190°C) from 5 cN to 40 cN.
7. The composition of any one of the previous claims, wherein the composition has a density from 0.910 to 0.925 g/cc.
8. The composition of any one of the previous claims, wherein the composition has a melt index (I2) from 0.1 to 1.5 g/10 min.

9. The composition of any one of the previous claims, wherein when said composition is formed into a film, via blown film process, the maximum output rate is at least 15 percent greater than the maximum output rate of a similar film formed from a similar composition, except the composition contains 100 wt% of the second ethylene-based polymer, based on the sum weight of the first ethylene-based polymer and the second ethylene-based polymer.
10. An article comprising at least one component formed from the composition of any one of the previous claims.
11. A film comprising at least one layer formed from the composition of any one of claims 1-9.
12. The film of claim 11, wherein the film comprises at least two layers.
13. The film of claim 11 or claim 12, wherein the film has a MD shrink tension greater than 3.00 psi.

FIGURE 1A

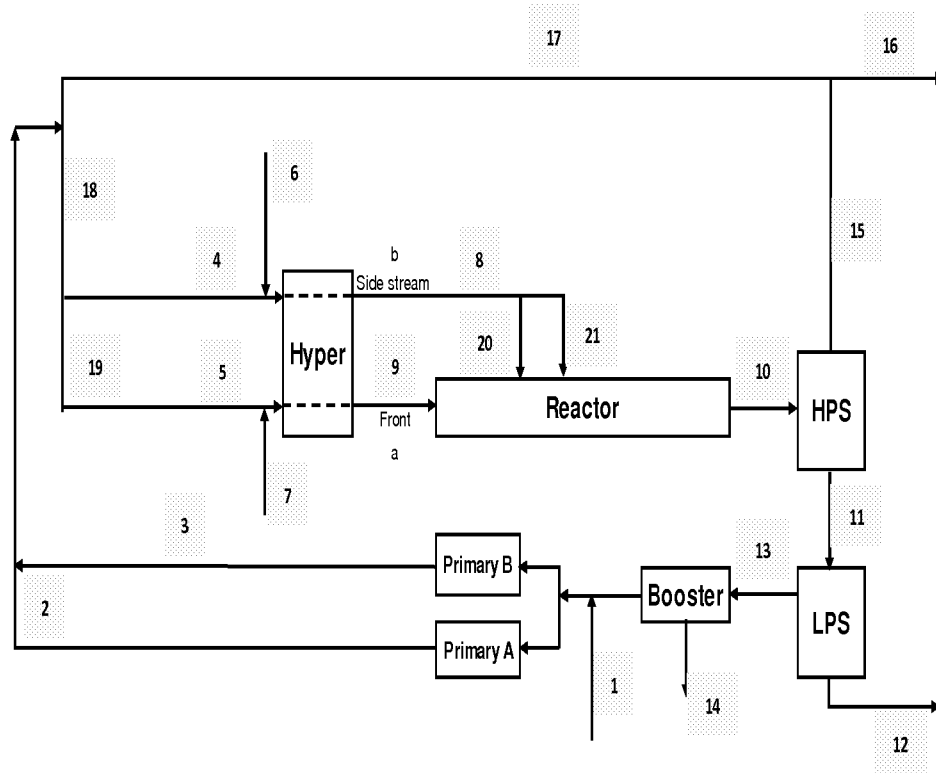

FIGURE 1B

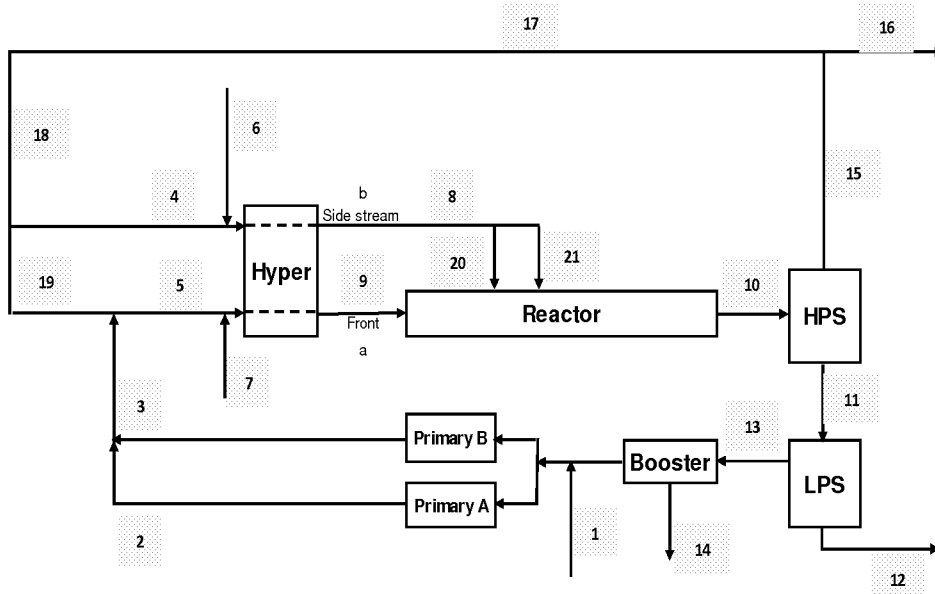

FIGURE 2

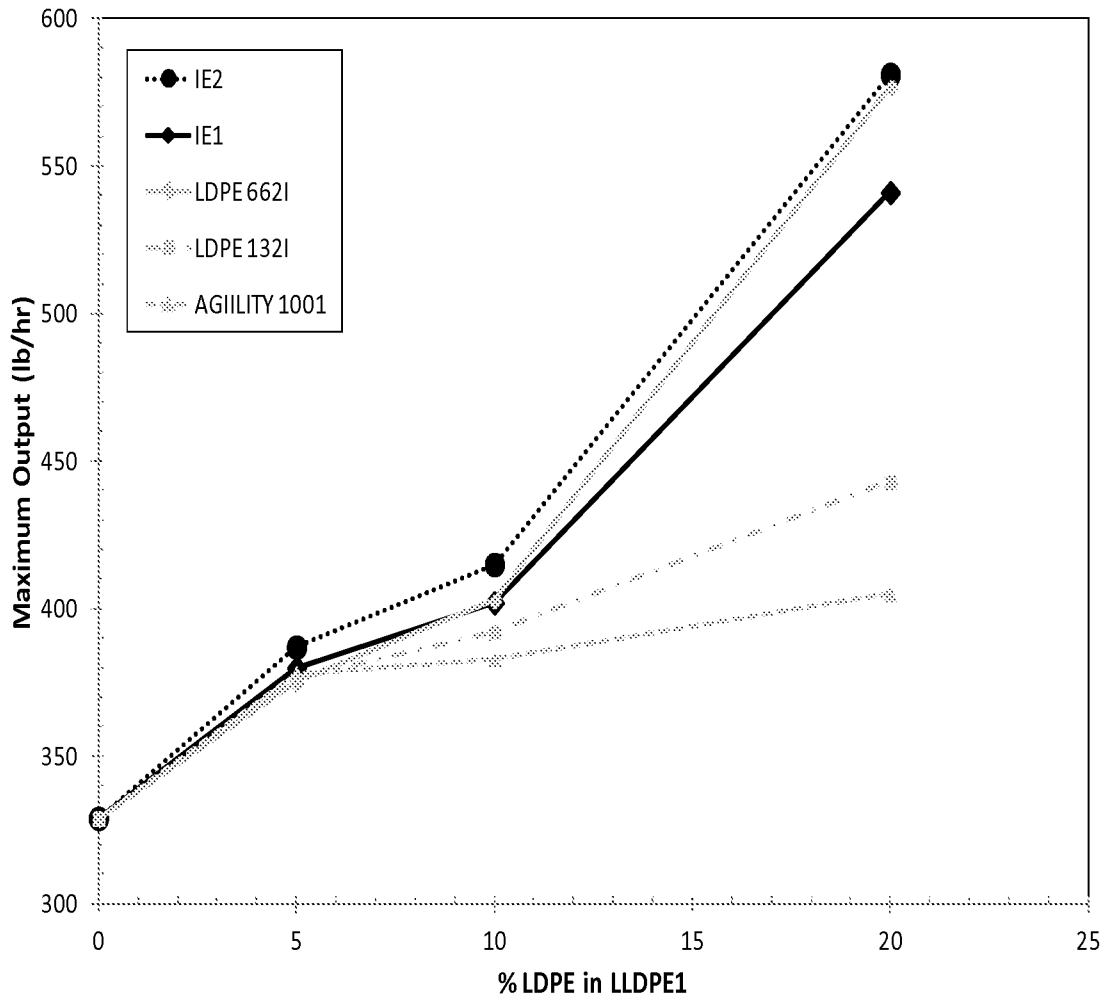

FIGURE 3

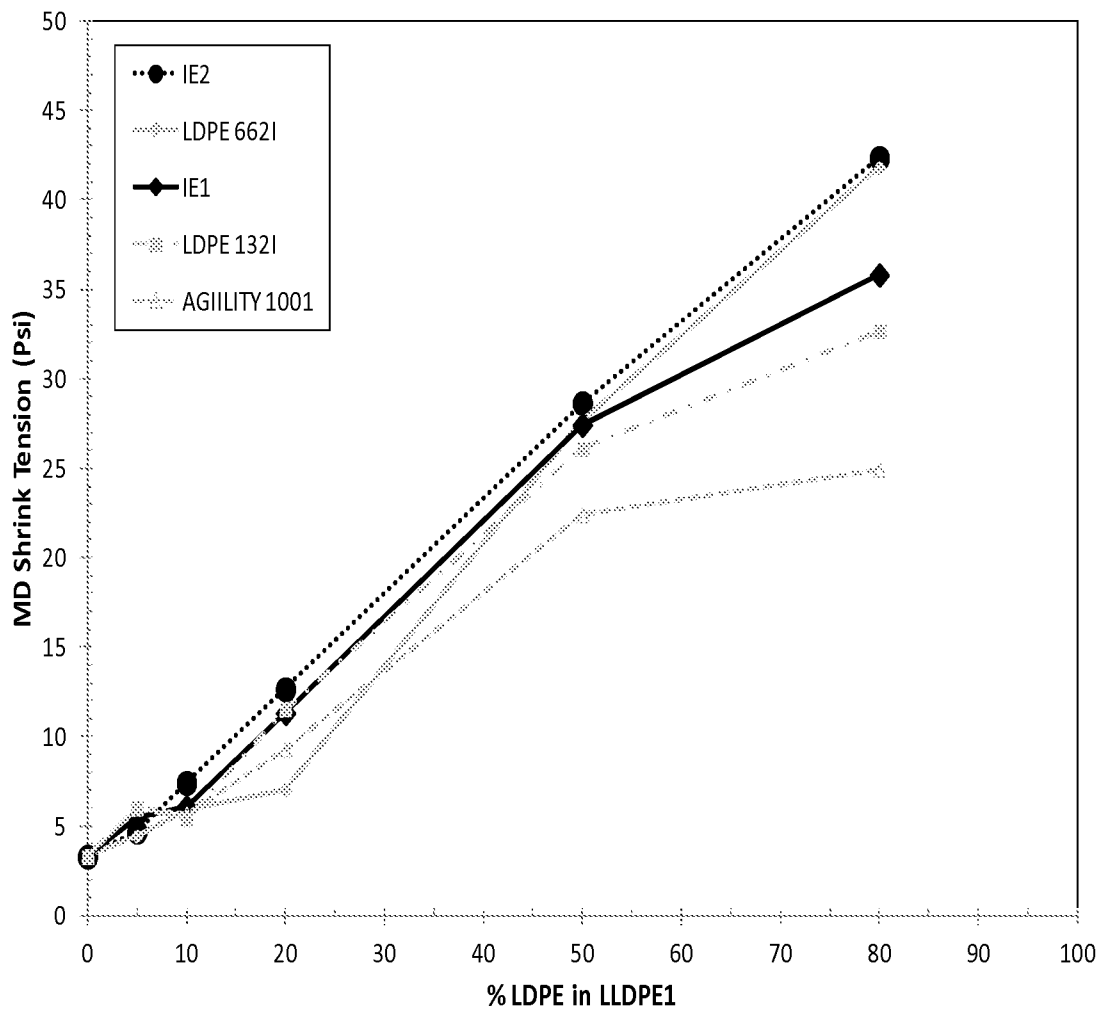
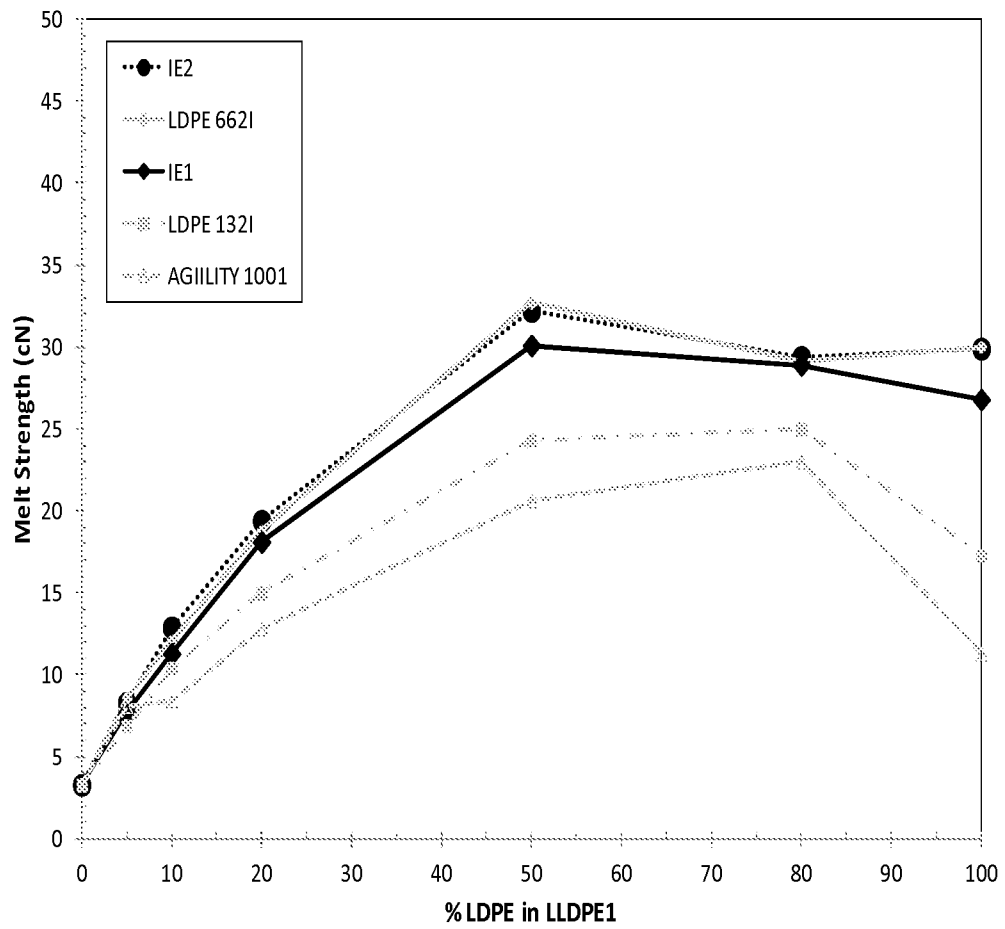

FIGURE 4



# INTERNATIONAL SEARCH REPORT

International application No <b>PCT/US2014/038944</b>
--

**A. CLASSIFICATION OF SUBJECT MATTER**  
**INV. C08L23/08**  
**ADD.**

According to International Patent Classification (IPC) or to both national classification and IPC

**B. FIELDS SEARCHED**

Minimum documentation searched (classification system followed by classification symbols)  
**C08L**

Documentation searched other than minimum documentation to the extent that such documents are included in the fields searched

Electronic data base consulted during the international search (name of data base and, where practicable, search terms used)

**EPO-Internal**

**C. DOCUMENTS CONSIDERED TO BE RELEVANT**

Category*	Citation of document, with indication, where appropriate, of the relevant passages	Relevant to claim No.
X	<p>WO 2013/009514 A1 (DOW GLOBAL TECHNOLOGIES LLC [US]; EFFLER LAWRENCE J [US]; SAVARGAONKAR) 17 January 2013 (2013-01-17) tables 1,2</p> <p style="text-align: center;">-----</p>	1-13

Further documents are listed in the continuation of Box C.

See patent family annex.

\* Special categories of cited documents :

"A" document defining the general state of the art which is not considered to be of particular relevance

"E" earlier application or patent but published on or after the international filing date

"L" document which may throw doubts on priority claim(s) or which is cited to establish the publication date of another citation or other special reason (as specified)

"O" document referring to an oral disclosure, use, exhibition or other means

"P" document published prior to the international filing date but later than the priority date claimed

"T" later document published after the international filing date or priority date and not in conflict with the application but cited to understand the principle or theory underlying the invention

"X" document of particular relevance; the claimed invention cannot be considered novel or cannot be considered to involve an inventive step when the document is taken alone

"Y" document of particular relevance; the claimed invention cannot be considered to involve an inventive step when the document is combined with one or more other such documents, such combination being obvious to a person skilled in the art

"&" document member of the same patent family

Date of the actual completion of the international search

10 July 2014

Date of mailing of the international search report

17/07/2014

Name and mailing address of the ISA/

European Patent Office, P.B. 5818 Patentlaan 2  
 NL - 2280 HV Rijswijk  
 Tel. (+31-70) 340-2040,  
 Fax: (+31-70) 340-3016

Authorized officer

Rouault, Yannick

# INTERNATIONAL SEARCH REPORT

International application No.  
PCT/US2014/038944

## Box No. II Observations where certain claims were found unsearchable (Continuation of item 2 of first sheet)

This international search report has not been established in respect of certain claims under Article 17(2)(a) for the following reasons:

1.  Claims Nos.:  
because they relate to subject matter not required to be searched by this Authority, namely:
  
2.  Claims Nos.: **1-13(partially)**  
because they relate to parts of the international application that do not comply with the prescribed requirements to such an extent that no meaningful international search can be carried out, specifically:  
**see FURTHER INFORMATION sheet PCT/ISA/210**
  
3.  Claims Nos.:  
because they are dependent claims and are not drafted in accordance with the second and third sentences of Rule 6.4(a).

## Box No. III Observations where unity of invention is lacking (Continuation of item 3 of first sheet)

This International Searching Authority found multiple inventions in this international application, as follows:

1.  As all required additional search fees were timely paid by the applicant, this international search report covers all searchable claims.
  
2.  As all searchable claims could be searched without effort justifying an additional fees, this Authority did not invite payment of additional fees.
  
3.  As only some of the required additional search fees were timely paid by the applicant, this international search report covers only those claims for which fees were paid, specifically claims Nos.:
  
4.  No required additional search fees were timely paid by the applicant. Consequently, this international search report is restricted to the invention first mentioned in the claims; it is covered by claims Nos.:

### Remark on Protest

- The additional search fees were accompanied by the applicant's protest and, where applicable, the payment of a protest fee.
- The additional search fees were accompanied by the applicant's protest but the applicable protest fee was not paid within the time limit specified in the invitation.
- No protest accompanied the payment of additional search fees.

**FURTHER INFORMATION CONTINUED FROM PCT/ISA/ 210**

Continuation of Box II.2

Claims Nos.: 1-13(partially)

Present claim 1 relates to a product defined (inter alia) by reference to the following unusual parameters:

a)  $M_w(\text{abs})/M_w(\text{GPC}) < 2.2$

b)  $MS \geq C \times [(I_2)_{<D>}]$ , where  $C = 13.5 \text{ cN}/(\text{dg}/\text{min})_{<D>}$ , and  $D = -0.55$ ,

The use of this unusual parameter in the present context is considered to lead to a lack of clarity because the claim does not clearly identify the products encompassed by it as the parameter cannot be clearly and reliably determined by indications in the description or by objective procedures which are usual in the art. This makes it impossible to compare the claim/s to the prior art. As a result, the application does not comply with the requirement of clarity under Article 6 PCT.

Parameter a) is in fact the comparison between two alternative ways of measuring the  $M_w$ , the calculation being made via a software.

The use of

a software as such to evaluate a physical value is not a problem, however the parameter  $M_w(\text{abs})/M_w(\text{GPC})$  is only a measure of the error on the estimation of the value of  $M_w$  by two different method. Moreover, as software are updated, this parameter may change with time with each new version of the software. It is not clear what is the physical meaning of  $M_w(\text{abs})/M_w(\text{GPC})$  since  $M_w(\text{abs})/M_w(\text{GPC})$  may also simply be a measure of the evolution of the software used.

The parameter b) is not common in the art and may be a kind of smoke screen hindering the comparison with the prior art.

The search of the claims does not take the parameters a) and b) in consideration.

The applicant's attention is drawn to the fact that claims relating to inventions in respect of which no international search report has been established need not be the subject of an international preliminary examination (Rule 66.1(e) PCT). The applicant is advised that the EPO policy when acting as an International Preliminary Examining Authority is normally not to carry out a preliminary examination on matter which has not been searched. This is the case irrespective of whether or not the claims are amended following receipt of the search report or during any Chapter II procedure. If the application proceeds into the regional phase before the EPO, the applicant is reminded that a search may be carried out during examination before the EPO (see EPO Guidelines C-IV, 7.2), should the problems which led to the Article 17(2) declaration be overcome.

# INTERNATIONAL SEARCH REPORT

Information on patent family members

International application No

PCT/US2014/038944

Patent document cited in search report	Publication date	Patent family member(s)	Publication date
WO 2013009514 A1	17-01-2013	CN 103649205 A	19-03-2014
		EP 2729527 A1	14-05-2014
		KR 20140043777 A	10-04-2014
		US 2014134364 A1	15-05-2014
		WO 2013009514 A1	17-01-2013
-----			