

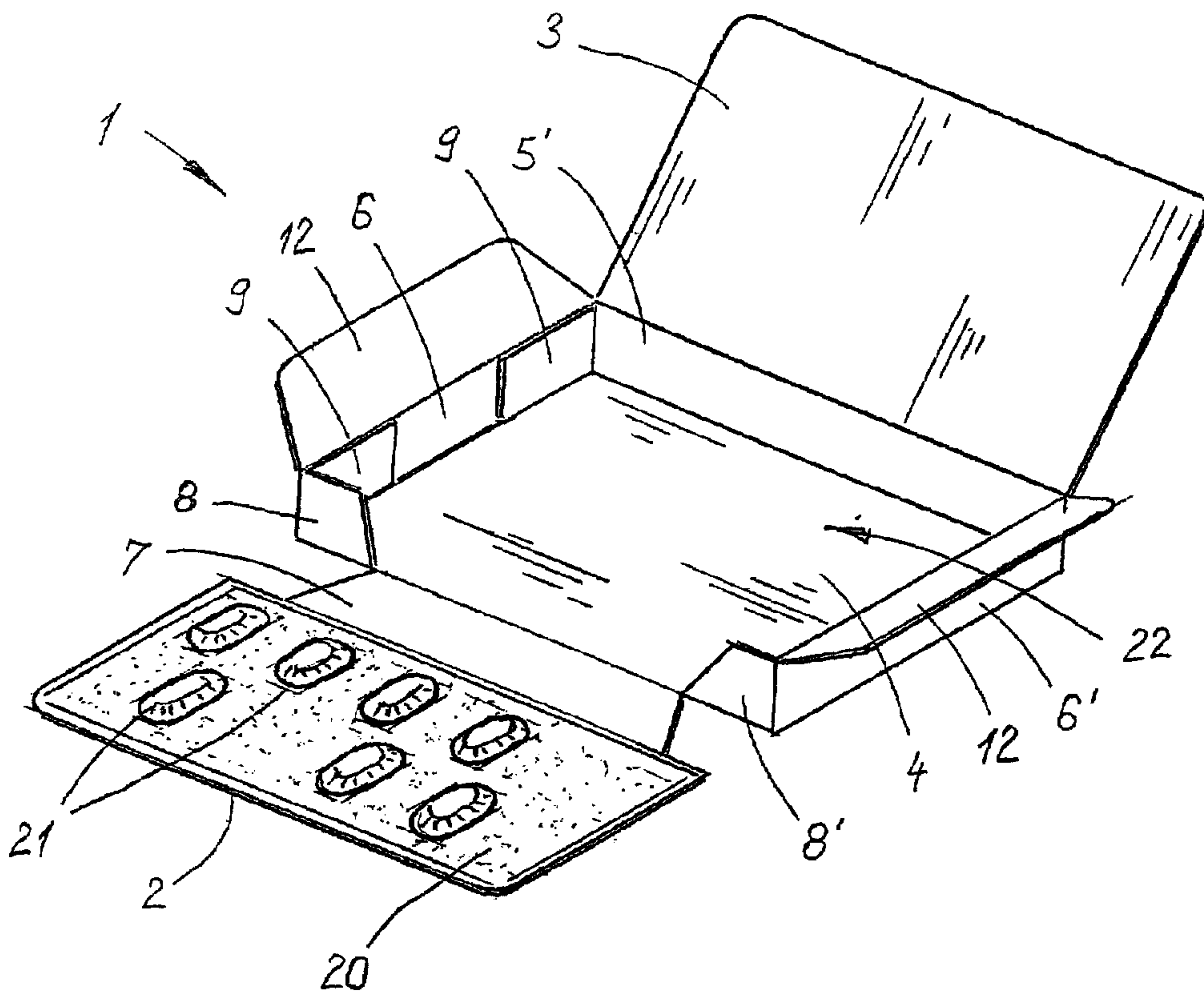

(86) Date de dépôt PCT/PCT Filing Date: 2001/11/12
 (87) Date publication PCT/PCT Publication Date: 2002/12/19
 (45) Date de délivrance/Issue Date: 2009/06/02
 (85) Entrée phase nationale/National Entry: 2003/11/18
 (86) N° demande PCT/PCT Application No.: CH 2001/000664
 (87) N° publication PCT/PCT Publication No.: 2002/100736
 (30) Priorité/Priority: 2001/06/11 (EP01114120.7)

(51) Cl.Int./Int.Cl. *B65D 75/36* (2006.01),
B65D 83/04 (2006.01)
 (72) Inventeurs/Inventors:
BREU, GERHARD, CH;
SPECKER, ERICH, CH
 (73) Propriétaire/Owner:
DIVIDELLA AG, CH
 (74) Agent: MCFADDEN, FINCHAM

(54) Titre : EMBALLAGE COMPORTANT AU MOINS UNE SECTION PORTEUSE CONTENANT UNE MARCHANDISE A
EMBALLER ET PROCEDE DE FABRICATION ET DE REMPLISSAGE DE CET EMBALLAGE
 (54) Title: PACKAGING COMPRISING AT LEAST ONE CARRIER SECTION BEARING A PACKAGING ITEM AND
METHOD FOR THE PRODUCTION AND FILLING OF SAID PACKAGING



(57) **Abrégé/Abstract:**

A carrier section (2) is captively integrated into a box which is stabilized in a folding and glueing operation, said box comprising four side walls(5, 5', 6, 6') connected approximately at right angles to a base section (4). One of the side walls is embodied in the form of an articulated strip (7), at least as far as part of the length thereof is concerned. Said strip can be pivoted on the plane of the base section (4) and is coupled to the carrier section (2).

(12) NACH DEM VERTRAG ÜBER DIE INTERNATIONALE ZUSAMMENARBEIT AUF DEM GEBIET DES
PATENTWESENS (PCT) VERÖFFENTLICHTE INTERNATIONALE ANMELDUNG(19) Weltorganisation für geistiges Eigentum
Internationales Büro(43) Internationales Veröffentlichungsdatum
19. Dezember 2002 (19.12.2002)

PCT

(10) Internationale Veröffentlichungsnummer
WO 02/100736 A1

- (51) Internationale Patentklassifikation⁷: B65D 75/36, 83/04
- (72) Erfinder; und
(75) Erfinder/Anmelder (nur für US): BREU, Gerhard [CH/CH]; Obere Grauensteinstrasse 16, CH-8594 Güttingen (CH). SPECKER, Erich [CH/CH]; Im Wideneisch 12, CH-9450 Altstätten (CH).
- (21) Internationales Aktenzeichen: PCT/CH01/00664
- (22) Internationales Anmeldedatum:
12. November 2001 (12.11.2001)
- (74) Anwälte: HEPP, Dieter usw.; Hepp, Wenger & Ryffel AG, Friedtalweg 5, CH-9500 Wil (CH).
- (25) Einreichungssprache: Deutsch
- (81) Bestimmungsstaaten (national): BR, CA, JP, US.
- (26) Veröffentlichungssprache: Deutsch
- (84) Bestimmungsstaaten (regional): europäisches Patent (AT, BE, CH, CY, DE, DK, ES, FI, FR, GB, GR, IE, IT, LU, MC, NL, PT, SE, TR).
- (30) Angaben zur Priorität:
01114120.7 11. Juni 2001 (11.06.2001) EP
- (71) Anmelder (für alle Bestimmungsstaaten mit Ausnahme von US): DIVIDELLA AG [CH/CH]; Werdenstrasse 76, CH-9472 Grabs (CH).
- Veröffentlicht:
— mit internationalem Recherchenbericht

[Fortsetzung auf der nächsten Seite]

(54) Title: PACKAGING COMPRISING AT LEAST ONE CARRIER SECTION BEARING A PACKAGING ITEM AND METHOD FOR THE PRODUCTION AND FILLING OF SAID PACKAGING

(54) Bezeichnung: VERPACKUNG, MIT WENIGSTENS EINEM EIN VERPACKUNGSGUT TRAGENDEN TRÄGERABSCHNITT UND VERFAHREN ZUM HERSTELLEN UND FÜLLEN DER VERPACKUNG

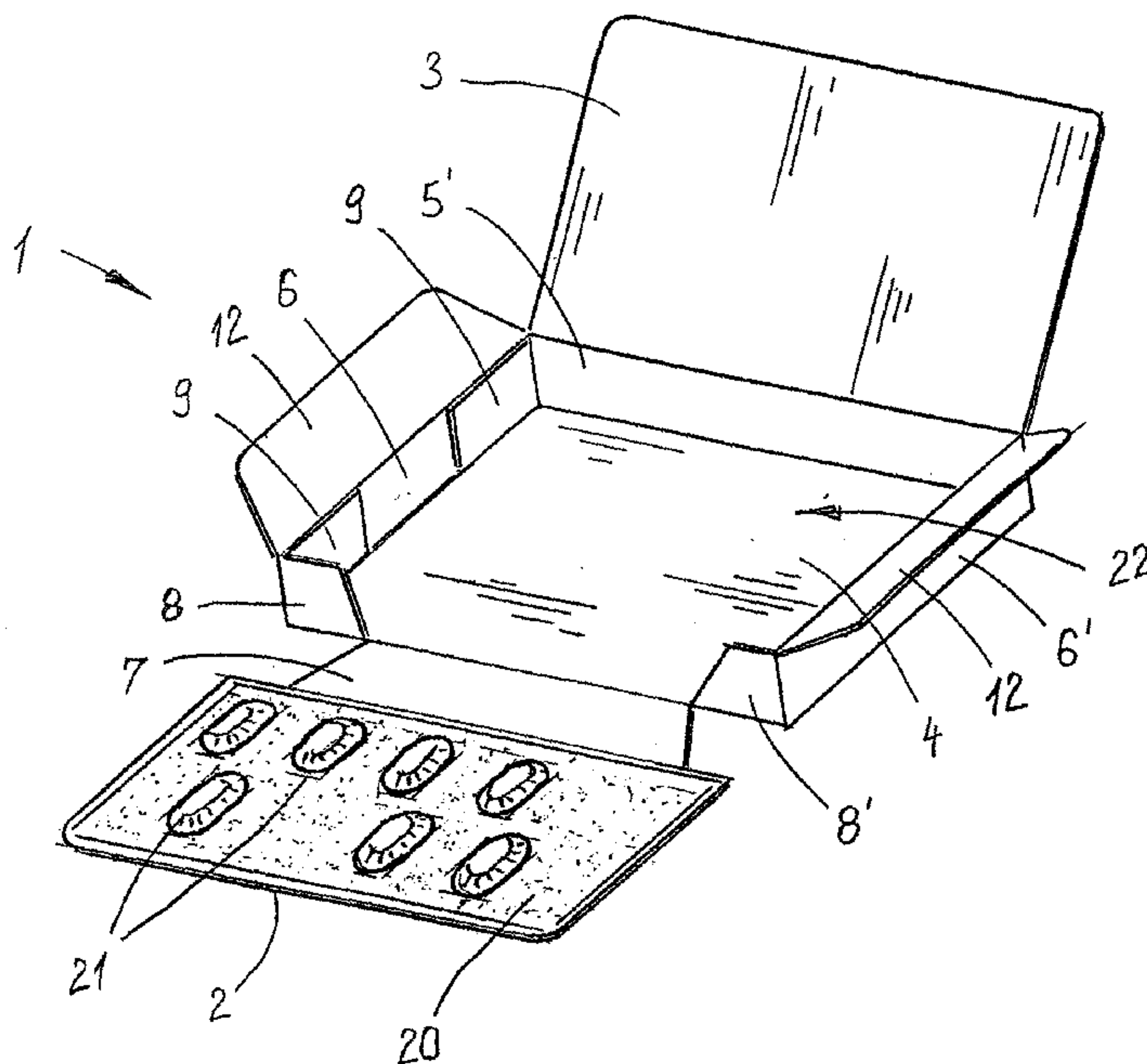

(57) Abstract: A carrier section (2) is captively integrated into a box which is stabilized in a folding and glueing operation, said box comprising four side walls(5, 5', 6, 6') connected approximately at right angles to a base section (4). One of the side walls is embodied in the form of an articulated strip (7), at least as far as part of the length thereof is concerned. Said strip can be pivoted on the plane of the base section (4) and is coupled to the carrier section (2).

[Fortsetzung auf der nächsten Seite]

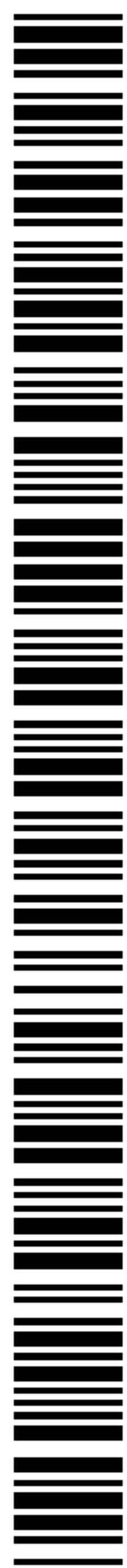

WO 02/100736 A1



Zur Erklärung der Zweibuchstaben-Codes und der anderen Abkürzungen wird auf die Erklärungen ("Guidance Notes on Codes and Abbreviations") am Anfang jeder regulären Ausgabe der PCT-Gazette verwiesen.

(57) Zusammenfassung: Ein Trägerabschnitt (2) ist unverlierbar in eine durch Falz- und Klebeoperationen stabilisierte Schachtel integriert, welche vier etwa rechtwinklig an einem Bodenabschnitt (4) anschliessende Seitenwände (5, 5', 6, 6') aufweist. Eine der Seitenwände ist wenigstens über einen Teil ihrer Länge als Gelenkstreifen (7) ausgebildet, der in die Ebene des Bodenabschnitts (4) schwenkbar ist und an dem der Trägerabschnitt (2) angelenkt ist.

**PACKAGING COMPRISING AT LEAST ONE CARRIER SECTION BEARING
A PACKAGING ITEM AND METHOD FOR THE PRODUCTION AND FILLING
OF SAID PACKAGING**

- 5 The invention relates to packaging comprising at least one carrier section bearing packaging contents according to the preamble of independent claims 1 and 6. In the case of such packaging, in contrast to packaging contents being packaged loosely in boxes, at
10 least one carrier section is firmly connected to a protective casing which encloses it, with the result that the packaging contents, e.g. a blister sheet, cannot be damaged accidentally.
- 15 Packaging of a comparable generic type has been disclosed, for example, by GB-A-2 266 880. The protective casing here forms a type of wallet, in the case of which the blister section is integral with a narrow side. One disadvantage of this packaging,
20 however, is that the protective casing is not resistant to pressure because it does not have any stable side walls. Moreover, it is possible for dust and dirt to penetrate into the corner regions.
- 25 An alternative solution of such packaging has been disclosed by US-A-5,954,202. According to a particular embodiment, the side walls which adjoin the base section are connected to one another in the erected position. The operations of erecting and stabilizing
30 the box prior to loading of the carrier section, however, are only possible with considerable outlay because, for the loading operation, the carrier section should lie flat.
- 35 It is thus an object of the invention to provide packaging of the type mentioned in the introduction which combines the advantages of a stable box for the packaging contents with a single-piece design of the blank, without the production of the packaging being

- 2 -

rendered excessively more difficult in the process.

5 The present invention provides, in one embodiment, a package with at least one carrying section carrying a packaged product and a box connected to the carrying section with at least one base section, and one lid section, wherein the carrying section is articulated to the box in such a manner that it can be swung out of a rest position between the base section and the lid section into an in-use position, wherein the box has four side walls joining the base section
10 approximately at right angles, wherein one side wall forms an articulation strip which is connected to the adjoining box side walls in each case via one articulation fold in such a manner that in the in-use position the carrying section can be swiveled out into a plane of the base section and the adjoining box side walls are stabilized at least in the rest position, wherein the side walls are
15 formed as approximately prismatic hollow side walls, each with one outer wall and one inner wall which can be erected in the manner of a parallelogram from the plane of the base section and wherein each articulation fold joins onto an outer wall of a hollow side wall and the carrying section is articulated to the articulation strip.

20

According to a first preferred embodiment of the invention, one side wall forms an articulation strip which is connected to the abutting box side walls such that the carrier section, in the use position, can be pivoted into the plane of the base section, and that the abutting box side walls are stabilized at least in the rest
25 position, the carrier section being articulated on the articulation strip. The connection advantageously takes place via in each case one articulation fold, which connects the articulation strip to the abutting box side walls in each possible relative position.

30 The abutting box side walls are advantageously designed as approximately prismatic hollow side walls each with an outer wall and an inner wall, which can be erected in the manner of a parallelogram from the plane of the base section. It is possible here for each articulation fold to adjoin an outer wall of a hollow side wall. Packs comprising a single blank with hollow side walls have already

- 2a -

been disclosed, for example, by EP-A-172 133. Such packaging has the
advantage that it can be supplied in the flat state as prefabricated blanks, and
5 that good stability in relation to pressure is achieved once the hollow side walls
have been erected.

It is particularly advantageous for the folded-in articulation fold in the rest
position, in the case of each hollow side wall, to butt against the inner wall on
10 the end side, as a result of which it is retained in the plane of the erected
articulation strip. The situation where the hollow side wall is pivoted outward

15

20

25

30

is thus reliably avoided, because the articulation fold cannot open.

The lid section may be articulated on the base section
5 in precisely the same way as the carrier section. In particular, it may likewise be arranged on a wall section which is connected to the abutting box side walls via in each case one articulation fold.

10 According to an alternative embodiment of the invention, it is possible for at least one side wall to form an articulation strip which extends only over part of the side length of the box, it being the case that remaining on both sides of the articulation strip is in
15 each case one residual side wall which is firmly connected to abutting box side walls and adjoins the articulation strip in the rest position. Here too, the carrier section, which is articulated on the articulation strip, can be pivoted into the plane of
20 the base section in the use position, although the box is stabilized in the rest position and in the use position.

In this way, the box achieves four rigidly adhesively
25 bonded corner regions, as a result of which the stability in relation to pressure and the torsional rigidity is obviously increased. It is particularly advantageous here if the articulation strip butts against the residual side walls in the rest position,
30 with the result that sufficient sealing is achieved. The sealing of the packaging may be increased further if the lid section is articulated on the box side wall parallel to the articulation strip and if in each case one dust flap is arranged on the box side walls running
35 transversely to the articulation strip.

Depending on the size of the box, at least a second carrier section may be arranged on a first carrier

section via an articulation crosspiece. The articulation crosspiece, at the same time, ensures a certain spacing between the two carrier sections in the rest position. It would also be conceivable for a plurality of carrier sections to be positioned one beside the other in a row in the manner of an accordion.

The lid section may be retained in the closed position by at least one adhesive strip. It would also be conceivable, however, to have at least one insertion tongue, as is already known per se in the case of folding boxes.

The carrier section may bear, for example, a blister sheet with the packaging contents welded therein. Such blister sheets are also used, in particular, for packaging pharmaceutical products, such as pills or capsules. The carrier section here may have openings, the blister sheet being adhesively bonded to the carrier section such that the packaging contents welded therein, for example, tablets or capsules, are located in the region of the openings. In this way, it is possible for the packaging contents to be pressed through the openings for removal purposes.

It is also possible, however, for the carrier section to bear at least one individual container which can be separated off at a predetermined breaking point. The individual container may be a bottle-like or ampoule-like structure made of plastic material. A foil bag, tubular bag or the like, however, is also conceivable. Such containers are also used, for example, for giving away samples of perfume, ointments, etc.

The individual container may have a removal opening with a closure element, and the closure element may be

connected directly or indirectly to the carrier section, and the predetermined breaking point may be arranged between the removal opening and closure element, such that the individual container is opened
5 once it has been separated off. An entire continuous row of individual containers may particularly advantageously be arranged on the carrier section.

The invention also relates to a method of producing and
10 filling packaging described above, which has the features in claim 15. Considerable rationalization is achieved here in that the operations of producing a stable box and of fitting the packaging contents in captive fashion can take place one behind the other on
15 the same packaging line. It is also the case that, once the box has been erected and adhesively bonded, the carrier section remains on the same horizontal plane as the base section, with the result that the packaging contents can be attached by adhesive bonding.

20

The blanks used for producing the box are preferably printed beforehand, a further advantage of the packaging being that it is also possible for the end sides to contain information which is clearly visible
25 during storage. Before the carrier section is swung in, a separate information leaflet may be positioned in the box. As an alternative, or in addition, it would also be possible for an information leaflet to be fastened on the inside of the lid section, to be precise
30 preferably before the box is erected.

Further advantages and individual features can be gathered from the following description of exemplary
embodiments and from the drawings, in which:

35

Figure 1 shows a first blank for a box with four rigidly adhesively bonded corner regions,

Figure 2 shows an only partially illustrated second blank for a box with a side wall which can be swung out to the full extent,

5 Figure 3 shows a third blank with two carrier sections,

10 Figure 4 shows a perspective illustration of packaging produced from the first blank according to Figure 1,

Figure 5 shows the packaging according to Figure 4 with the carrier section swung in,

15 Figure 6 shows a perspective illustration of packaging produced from the second blank according to Figure 3,

20 Figure 7 shows a perspective illustration of a further exemplary embodiment of packaging with individual containers,

25 Figure 8 shows a perspective illustration of a further exemplary embodiment of packaging with alternative individual containers,

Figure 9 shows a fourth blank for a box with prismatic hollow side walls,

30 Figure 10 shows a perspective illustration of packaging produced from the blank according to Figure 9, and

35 Figure 11 shows an enlarged plan view of the end side of a hollow side wall with abutting articulation fold.

Figure 1 shows a single continuous blank 15, for example made of cardboard or of a laminate, with a rectangular base section 4, the longitudinal side walls 5, 5' adjoining the longitudinal sides of the latter and the transverse side walls 6, 6' adjoining the transverse sides thereof. In each case one dust flap 12 adjoins the transverse side walls 6, 6'. A carrier section 2 is arranged on the longitudinal side wall 5 and a lid section 3 is arranged on the longitudinal side wall 5'. Adhesive flaps 9 are also arranged at the ends of the longitudinal side walls 5, 5'.

The various material sections are separated from one another by folding lines 11. An exception here is constituted by the angled incisions 10, which subdivide the longitudinal side wall 5 into an articulation strip 7 and into two residual side walls 8, 8'. The incisions 10 here extend, as can be seen, over the entire width (corresponding to the subsequent height) of the longitudinal side wall 5.

Oval openings 13 are punched out of the carrier section 2, their configuration and position being adapted to a blister sheet which is subsequently attached by adhesive bonding.

The alternative blank 16 according to Figure 2 differs from the abovedescribed blank merely by the fact that the longitudinal side walls 5, 5' and the transverse side walls 6, 6' are connected to one another by an articulation fold. In this case, the entire longitudinal side wall 5 forms an articulation strip 7 which can be swung out around the articulation fold 14. In contrast, for the purpose of stabilizing the box, the articulation fold 14' may be adhesively bonded, with the result that a stable box is nevertheless produced.

Finally, the blank 17 according to Figure 3, in addition to a first carrier section 2a, also has a second carrier section 2b. The two carrier sections are connected to one another in an articulated manner via an articulation crosspiece 18. The rest of the material sections are configured in the same way as for the exemplary embodiment according to Figure 1.

Figure 4 shows the packaging 1 once the side walls have been erected and adhesively bonded. For this purpose, the adhesive flaps 9 are adhesively bonded to the transverse side walls 6 and 6'. As can be seen, the residual side walls 8, 8' remain in the erected position here, while the incisions 10 (Figure 1) ensure that the articulation strip 7, and thus also the carrier section 2, can be swung out into the plane of the base section 4.

In this position, a blister sheet 20, in which individual packaging chambers 21 are welded, is attached by adhesive bonding. Once the blister sheet has been attached by adhesive bonding, on the same packaging line, the carrier section 2 is swung into the interior 22 of the box.

This position is illustrated in Figure 5. The rear side of the blister sheet 20 can be seen through the openings 13, a packaging chamber being located behind each opening. Once the dust flaps 12 have been swung in, the lid section 3 is also closed and preferably fixed by an adhesive strip or by an insertion flap.

Figure 6 shows packaging 1 produced from the blank 17 according to Figure 3. The two separate carrier sections 2a and 2b have had likewise separate blister sheets 20a and 20b attached to them by adhesive bonding. For the purpose of closing the packaging, as can be seen, first of all the carrier section 2b is

moved onto the carrier section 2a around the articulation crosspiece 18, and the entire unit is then swung into the box interior 22. An information leaflet 19 is fastened in captive fashion on the inside of the lid section 3.

In the case of the exemplary embodiments according to Figures 7 and 8, the box body is constructed in the same manner as, or in a similar manner to, the exemplary embodiment according to Figure 4. The carrier sections 2, however, are configured somewhat differently and, instead of a blister sheet, the carrier sections bear a plurality of individual containers. According to Figure 7, the individual containers 23 are in the form of essentially round phials with a pouring nozzle and/or with a removal opening 24. The removal openings are closed by a closure element 25, and the closure elements are integrated as a whole in a fastening crosspiece. A predetermined breaking point 26 runs between the removal opening 24 and closure element 25, it also being possible for the individual containers 23 to be connected to one another by predetermined breaking points.

The fastening crosspiece 27 is adhesively bonded to the carrier section 2. This itself has an outline which is somewhat smaller than the outline of the base section 4. The individual containers 23 themselves are not connected to the carrier section 2. When an individual container is broken off, the closure element 25, as can be seen, remains on the fastening crosspiece 27, with the result that the container is opened at the same time as it is broken off.

In the case of the exemplary embodiment according to Figure 7, an insertion tongue 28 is also arranged on the lid section 3, it being possible for this tongue to

be inserted into a slit 30 once the carrier section has been swung into the box interior.

In the case of the exemplary embodiment according to Figure 8, the carrier section 2 merely comprises a relatively narrow strip. The individual containers 23 are ampoule-like structures made of plastic material which are arranged in a continuous row 29. The individual ampoules may be released from the carrier section 2 at the predetermined breaking point 26, it also then being necessary for the closure element 25 to be twisted off separately. Such containers are suitable, for example, for the individual portioning of adhesive or the like.

The blank 31 according to Figure 9, like the rest of the blanks, likewise has a base section 4 and a lid section 3, the latter being connected to the former in an articulated manner via a longitudinal side wall 5'. It is also the case that the carrier section 2 or 2' is connected to the base section 4 via the longitudinal side wall 5, which simultaneously forms the articulation strip 7.

In contrast to the exemplary embodiment according to Figure 3, the two sections 2 and 2' do not serve for accommodating separate blister sheets. Rather, the single blister sheet is adhesively bonded in a sandwich-like manner between the two carrier sections 2 and 2'. For this reason, it is also the case that the two sections are only separated from one another by a folding line. The cut-out openings are of different sizes. The removal openings 36 are somewhat smaller than the product openings 37, but are arranged in a mirror-inverted manner in relation to the same. The products welded in the blister sheet project out of the product openings 37, and are pressed out through the sheet at the removal openings 36.

For the formation of the side walls abutting the articulation strip 7, in each case one outer wall 32, 32' an inner wall 33, 33', a connecting crosspiece 34, 34' and an adhesive flap 35, 35' are arranged on the blank 31. The outer walls 32, 32' and the longitudinal side walls 5, 5' are connected to one another via in each case one articulation fold 14, 14'. Also arranged on the lid section 3 is an insertion tongue 28, which can be inserted into the slit 30 in the rest position.

For the purpose of preparing the blank 31, in the first instance the adhesive flaps 35, 35' are adhesively bonded to the base section 4, to be precise such that the sections 34, 34', 33, 33' and 35, 35' are swung over around the folding lines between 32 and 34 and between 32' and 34'. This principle is known to the person skilled in the art from EP-A-172 133, which was mentioned in the introduction. In this prefabricated state, the blank 31 may be fed to a loading station for loading with a blister sheet.

Figure 10 shows the packaging 1 which has been produced from the blank 31 and has the carrier section 2, 2' swung out into the plane of the base section 4. The hollow side walls 6, 6', or the outer walls 32, 32' thereof, remain connected to the carrier section here via in each case one articulation fold 14. It is indeed possible, but not absolutely necessary, for the articulation folds 14, 14' (which cannot be seen here) to be adhesively bonded to the longitudinal side wall 5' for stabilizing purposes. Their articulation function can be maintained, with the result that it is also possible for the lid section 3 to be pivoted back into the plane of the base section 4. The hollow side walls 6, 6' then tend to tilt some way outward on account of their restoring behavior. When the carrier section is folded in and/or when the lid section is

closed, the hollow side walls 6, 6' are nevertheless erected again into their vertical position.

It is particularly important in this context for it to
5 be possible for the closed articulation folds to be supported against the inner walls 31, 31' on the end side, as is illustrated in Figure 11. This is because a closed articulation fold 14 is thus fixed between the
10 end side of an inner wall 31 and the articulation strip 7 (or the longitudinal side wall 5'). It is because, in order for a hollow side wall to be pivoted outward in arrow direction a, the articulation fold would have to pivot out in arrow direction b, which is prevented by the fixing action. As can be seen, the packaging thus
15 remains fully stable in the corner regions in the rest position, even without adhesive bonding.

It would obviously also be possible for different
packaging contents to be fastened on the carrier
20 section, although it is not absolutely necessary for the packaging contents, for their part, to be enclosed in a sheet or in a container. In certain cases, it would be conceivable for the packaging contents to be adhesively bonded directly to the carrier section, for
25 example in the case of solid stick-like lighting aids, single-use nail files, puncture repair kits for bicycle wheels and the like.

- 13 -

CLAIMS:

1. A package with at least one carrying section carrying a packaged product and a box connected to the carrying section with at least one base section, and one lid section, wherein the carrying section is articulated to the box in such a manner that it can be swung out of a rest position between the base section and the lid section into an in-use position, wherein the box has four side walls joining the base section approximately at right angles, wherein one side wall forms an articulation strip which is connected to the adjoining box side walls in each case via one articulation fold in such a manner that in the in-use position the carrying section can be swiveled out into a plane of the base section and the adjoining box side walls are stabilized at least in the rest position, wherein the side walls are formed as approximately prismatic hollow side walls, each with one outer wall and one inner wall which can be erected in the manner of a parallelogram from the plane of the base section and wherein each articulation fold joins onto an outer wall of a hollow side wall and the carrying section is articulated to the articulation strip.
2. The package according to claim 1, wherein in the rest position, the articulation fold is folded in and lies on a face against the inner wall in the case of each hollow side wall and is thereby kept in the plane of the articulation strip in an upright position.
3. The package according to claim 1 or 2, wherein the lid section is articulated to the base section in the same manner as the carrying section.
4. The package according to any one of claims 1 to 3, wherein said at least one carrying section comprises a first carrying section and at least one second carrying section, the at least one second carrying section being attached to the first carrying section via an articulation link.
5. The package according to any one of claims 1 to 4, wherein the lid

section is held in a closed position by at least one adhesive strip.

6. The package according to any one of claims 1 to 4, wherein the lid section is held in a closed position by at least one insertion tongue.

7. The package according to any one of claims 1 to 6, wherein the carrying section carries a blister sheet with welded-in packaged product.

8. The package according to claim 7, wherein the carrying section has apertures and the blister sheet is glued onto the carrying section in such a manner that the welded-in packaged product lies in a region of the apertures.

9. The package according to any one of claims 1 to 8, wherein the carrying section carries at least one individual receptacle which can be separated off at a predetermined break-off point.

10. The package according to claim 9, wherein the individual receptacle has a removal aperture with a closing element and the closing element is directly or indirectly connected to the carrying section and the predetermined break-off point is arranged between removal aperture and closing element in such a way that the individual receptacle is opened after separation.

11. The package according to claim 9 or 10, wherein a coherent row of individual receptacles is attached to the carrying section.

12. A process for producing and filling packages according to any one of claims 1 to 11, comprising the steps of:

feeding prepared folding box blanks for packages according to any one of claims 1 to 11 to a loading station wherein the carrying section at first remains in the plane of the base section;

affixing at least one packaged product to the carrying section;

- 15 -

erecting the box from the folding box blank;
swinging the carrying section into the box; and
closing the box with the lid section.

Fig. 4

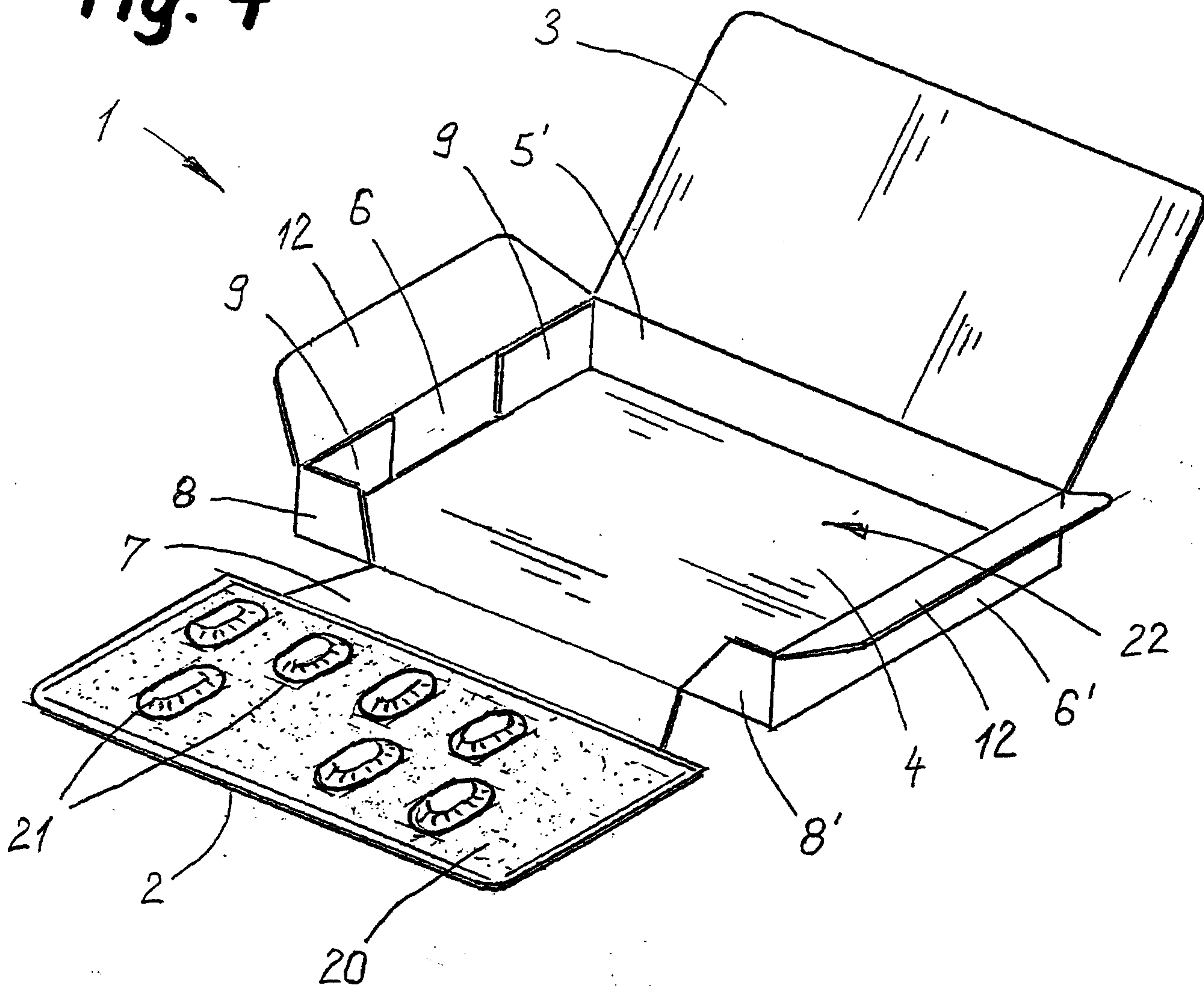

Fig. 5

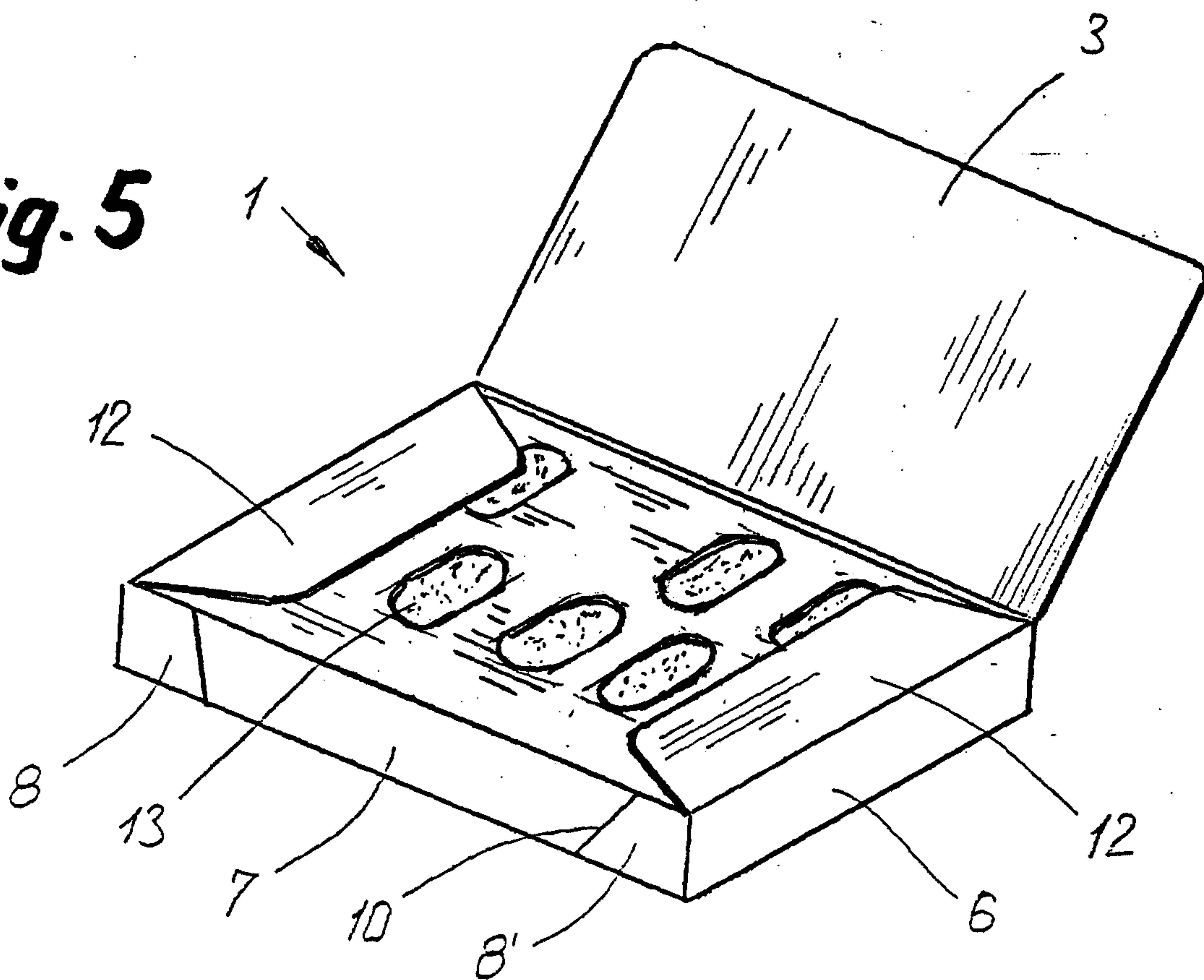

Fig. 7

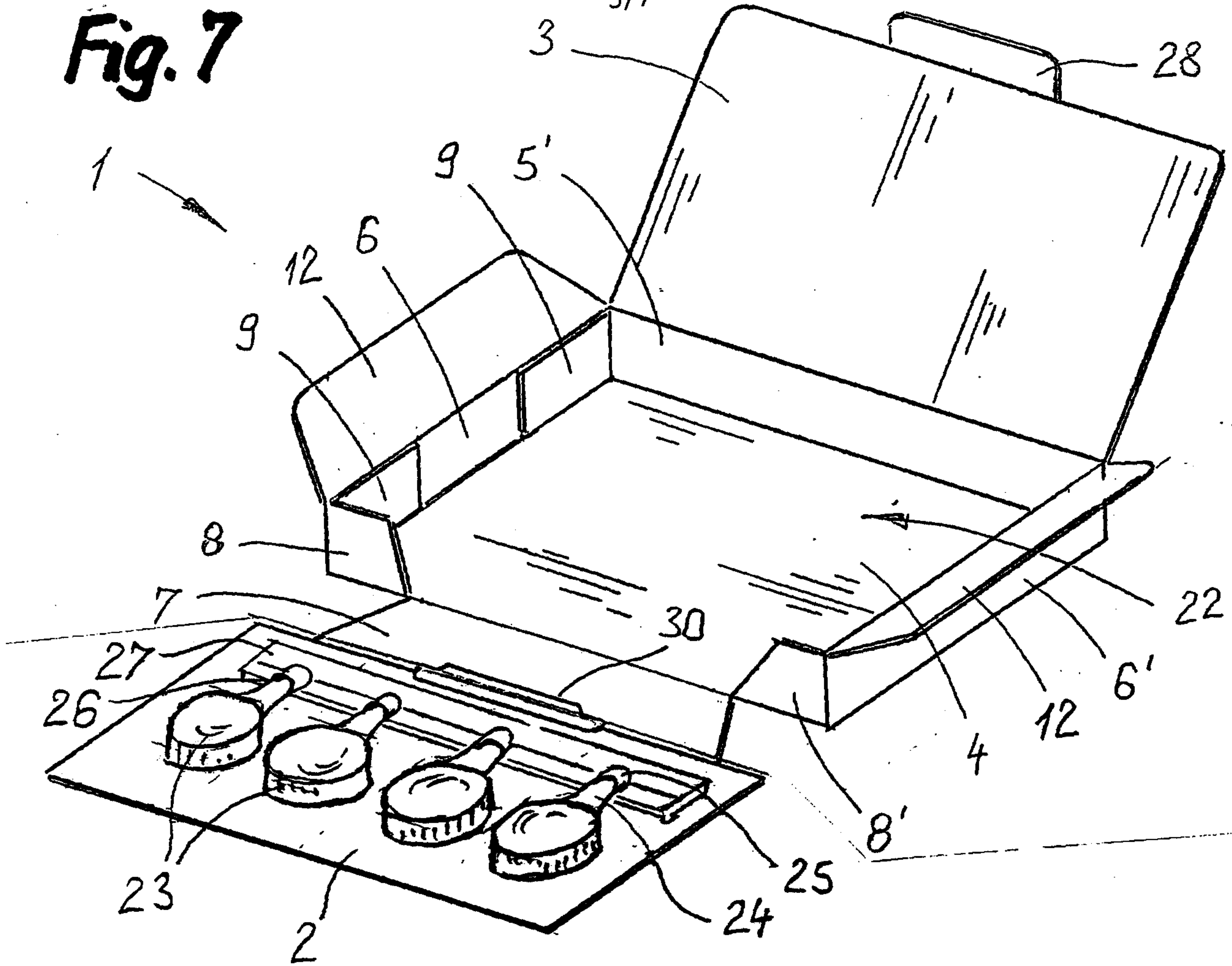

Fig. 8

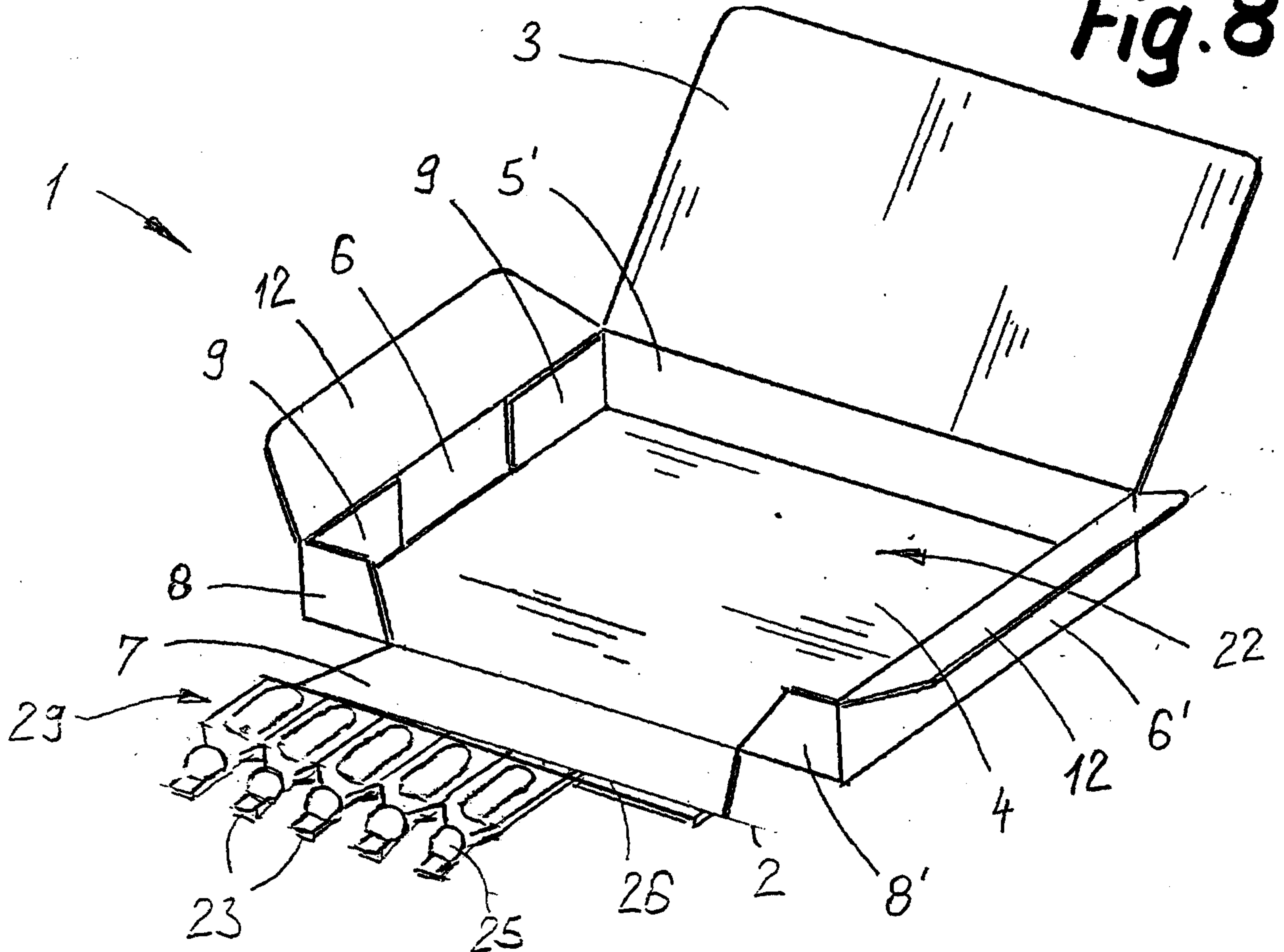

Fig. 9

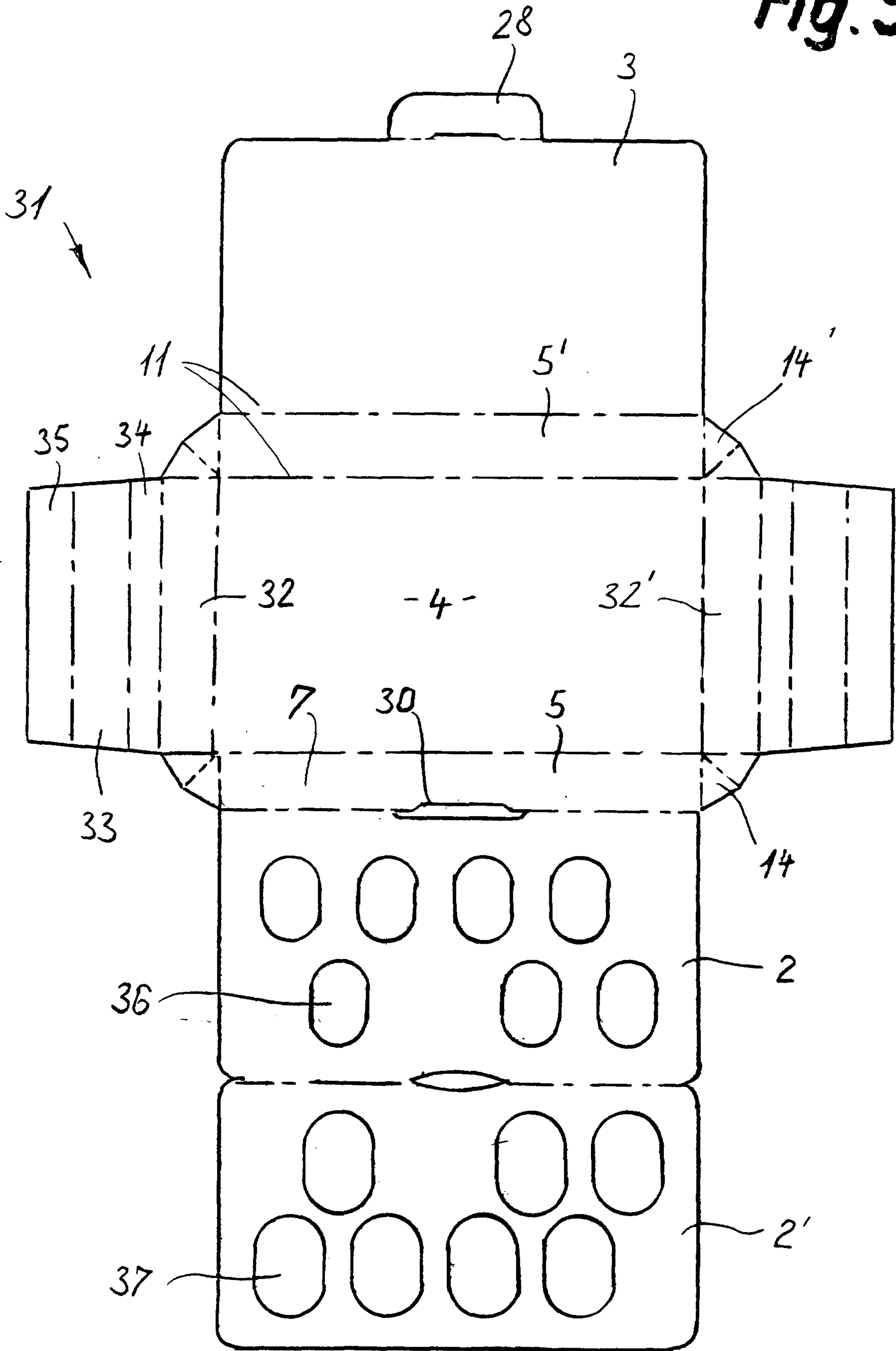

Fig. 10

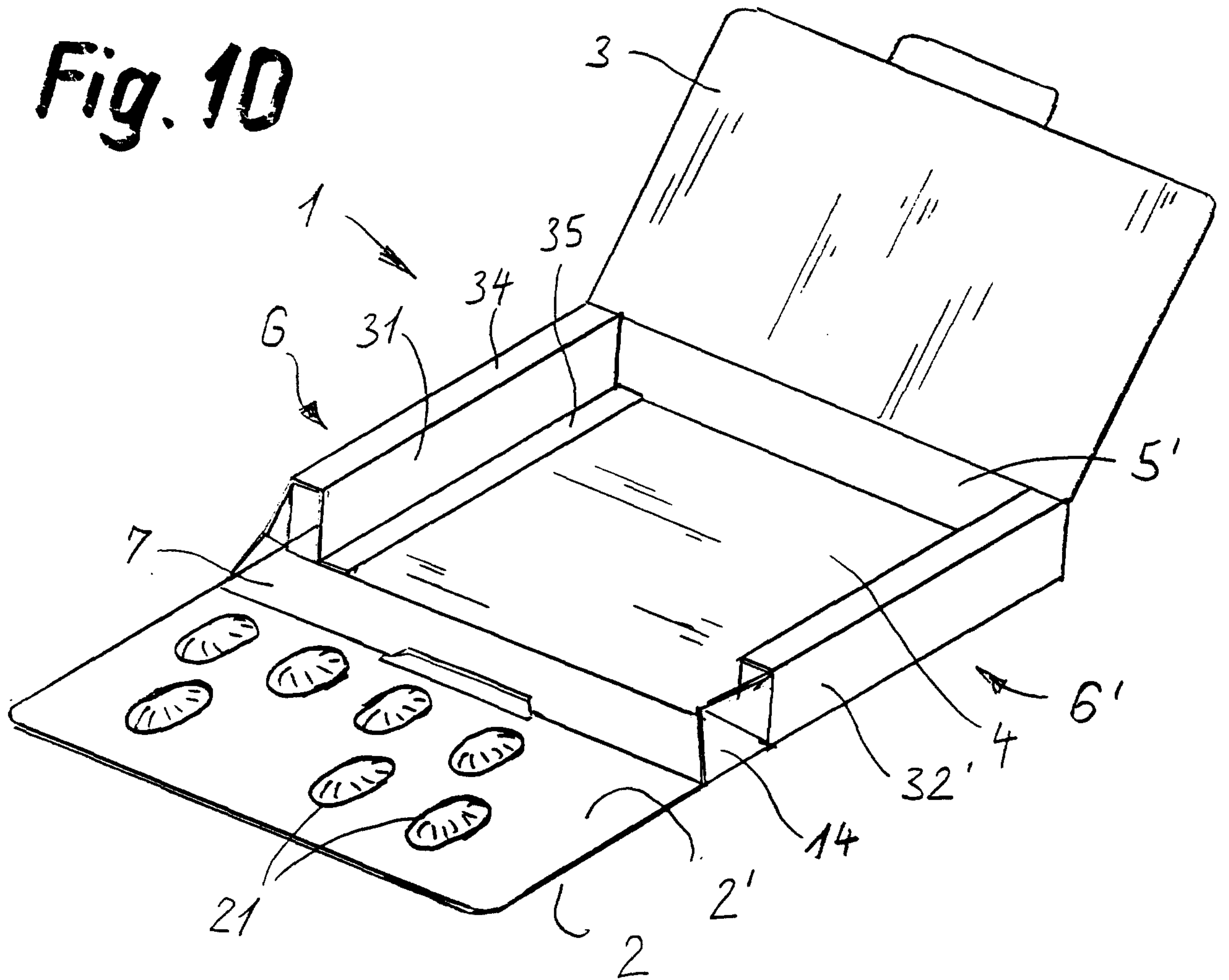

Fig. 11

