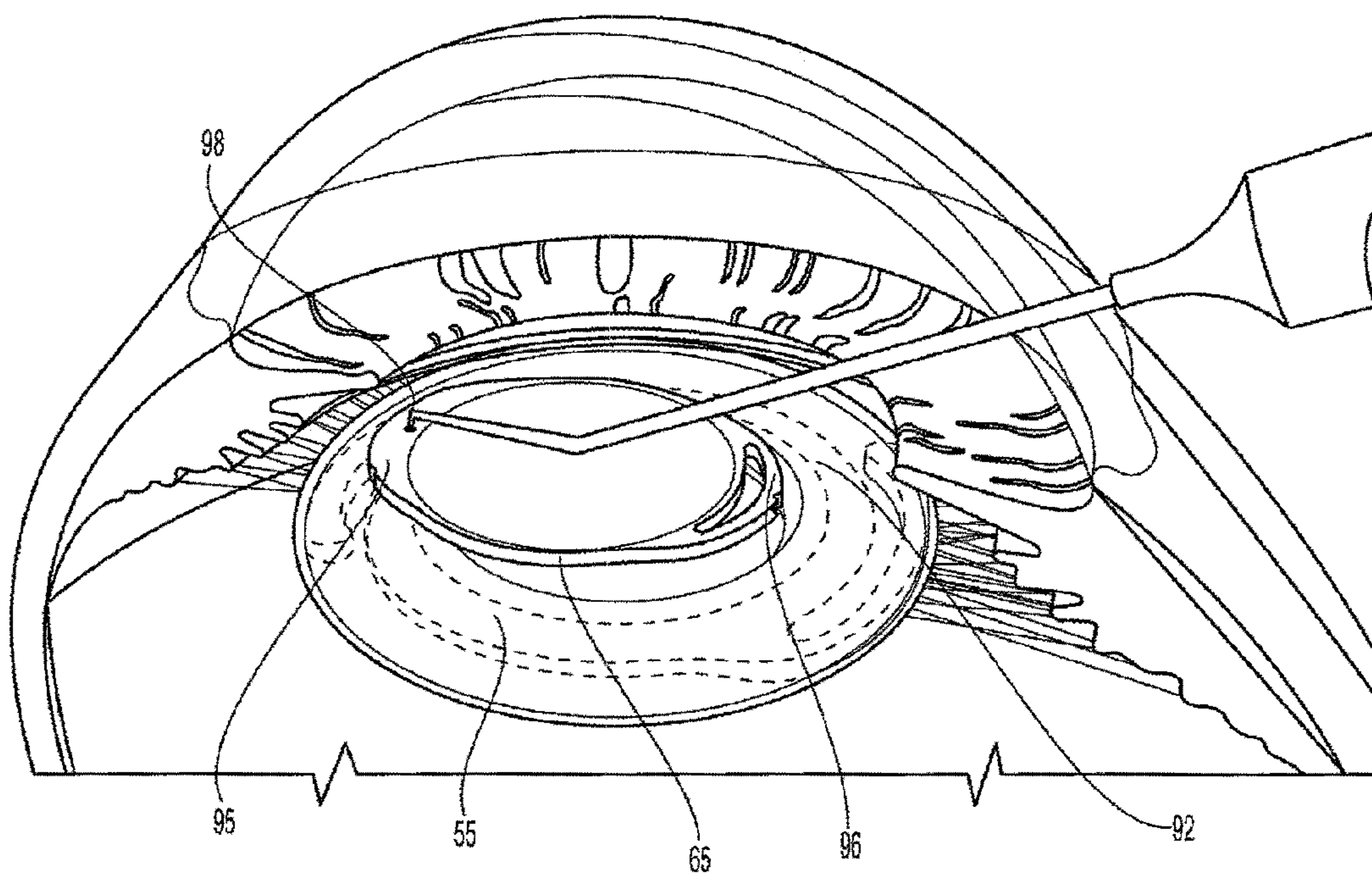




(86) Date de dépôt PCT/PCT Filing Date: 2015/12/21  
 (87) Date publication PCT/PCT Publication Date: 2016/08/04  
 (85) Entrée phase nationale/National Entry: 2017/07/21  
 (86) N° demande PCT/PCT Application No.: US 2015/067035  
 (87) N° publication PCT/PCT Publication No.: 2016/122805  
 (30) Priorités/Priorities: 2015/01/30 (US62/110,241);  
 2015/08/17 (US14/828,083)

(51) Cl.Int./Int.Cl. *A61F 2/16* (2006.01),  
*A61F 9/007* (2006.01)  
 (71) Demandeurs/Applicants:  
 CLARVISTA MEDICAL, INC., US;  
 THE REGENTS OF UNIVERSITY OF COLORADO, A  
 BODY CORPORATE, US  
 (72) Inventeurs/Inventors:  
 KAHOOK, MALIK Y., US;  
 SUSSMAN, GLENN, US;  
 MCLEAN, PAUL, US;  
 SCHIEBER, ANDREW, US  
 (74) Agent: PARLEE MCLAWS LLP

(54) Titre : CONCEPTIONS DE LENTILLE INTRAOCULAIRE MODULAIRE  
 (54) Title: MODULAR INTRAOCULAR LENS DESIGNS



**Fig. 4F**

(57) **Abrégé/Abstract:**

Modular IOL systems including a base (55) and a lens (65), wherein the lens includes fixed (95) and actuable tabs (96) for connection to the base. The modular IOL allows for the lens to be adjusted or exchanged while leaving the base in place, either intra-operatively or postoperatively. Drug delivery capabilities and/or sensing capabilities may be incorporated into the base. Injector devices may be used to facilitate placement of the base and the lens sequentially or simultaneously into the eye.

(12) INTERNATIONAL APPLICATION PUBLISHED UNDER THE PATENT COOPERATION TREATY (PCT)

(19) World Intellectual Property  
Organization  
International Bureau(43) International Publication Date  
4 August 2016 (04.08.2016)(10) International Publication Number  
**WO 2016/122805 A1**

- (51) **International Patent Classification:**  
*A61F 2/16* (2006.01)
- (21) **International Application Number:**  
PCT/US2015/067035
- (22) **International Filing Date:**  
21 December 2015 (21.12.2015)
- (25) **Filing Language:** English
- (26) **Publication Language:** English
- (30) **Priority Data:**  
62/110,241 30 January 2015 (30.01.2015) US  
14/828,083 17 August 2015 (17.08.2015) US
- (71) **Applicants:** CLARVISTA MEDICAL, INC. [US/US]; 26800 Alison Viejo Parkway, Suite 120, Aliso Viejo, CA 92656 (US). THE REGENTS OF THE UNIVERSITY OF COLORADO, A BODY CORPORATE [US/US]; 1800 Grant Street, 8th Floor, Denver, CO 80238 (US).
- (72) **Inventors:** KAHOOK, Malik, Y.; 9102 E. 34th Avenue, Denver, CO 80238 (US). SUSSMAN, Glenn; 28602 Rancho Grande, Laguna Niguel, CA 92677 (US). MCLEAN, Paul; 15 Dove Lane, North Oaks, MN 55127 (US). SCHIEBER, Andrew; 24470 Avenida De Los Ninos, Laguna Niguel, CA 92677 (US).
- (74) **Agent:** MELWANI, Dinesh, N.; Bookoff Mcandrews, PLLC, 2401 Pennsylvania Avenue, Nw, Suite 450, Washington, DC 20037 (US).
- (81) **Designated States** (*unless otherwise indicated, for every kind of national protection available*): AE, AG, AL, AM, AO, AT, AU, AZ, BA, BB, BG, BH, BN, BR, BW, BY, BZ, CA, CH, CL, CN, CO, CR, CU, CZ, DE, DK, DM, DO, DZ, EC, EE, EG, ES, FI, GB, GD, GE, GH, GM, GT, HN, HR, HU, ID, IL, IN, IR, IS, JP, KE, KG, KN, KP, KR, KZ, LA, LC, LK, LR, LS, LU, LY, MA, MD, ME, MG, MK, MN, MW, MX, MY, MZ, NA, NG, NI, NO, NZ, OM, PA, PE, PG, PH, PL, PT, QA, RO, RS, RU, RW, SA, SC, SD, SE, SG, SK, SL, SM, ST, SV, SY, TH, TJ, TM, TN, TR, TT, TZ, UA, UG, US, UZ, VC, VN, ZA, ZM, ZW.
- (84) **Designated States** (*unless otherwise indicated, for every kind of regional protection available*): ARIPO (BW, GH, GM, KE, LR, LS, MW, MZ, NA, RW, SD, SL, ST, SZ, TZ, UG, ZM, ZW), Eurasian (AM, AZ, BY, KG, KZ, RU, TJ, TM), European (AL, AT, BE, BG, CH, CY, CZ, DE, DK, EE, ES, FI, FR, GB, GR, HR, HU, IE, IS, IT, LT, LU, LV, MC, MK, MT, NL, NO, PL, PT, RO, RS, SE, SI, SK, SM, TR), OAPI (BF, BJ, CF, CG, CI, CM, GA, GN, GQ, GW, KM, ML, MR, NE, SN, TD, TG).

[Continued on next page]

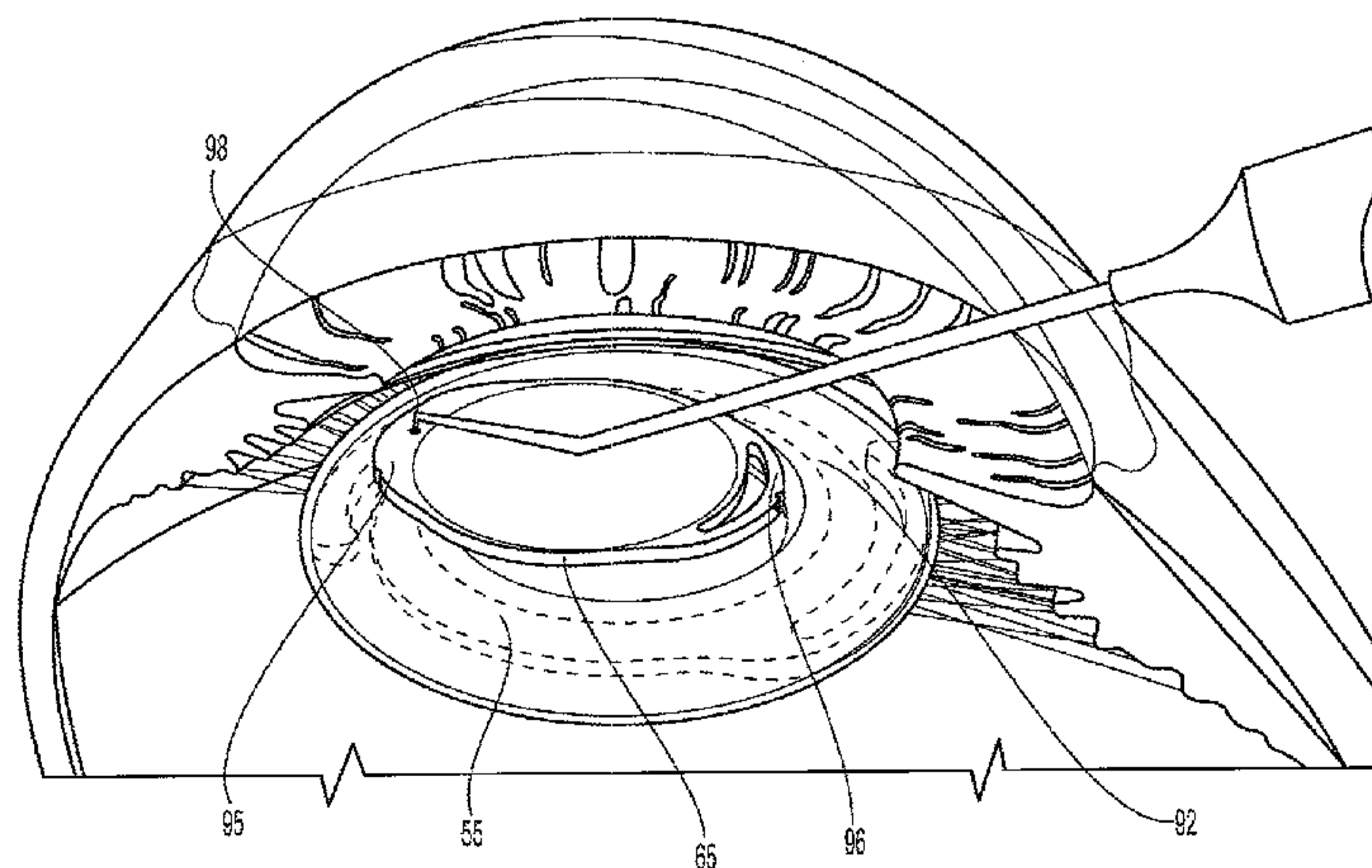
(54) **Title:** MODULAR INTRAOCULAR LENS DESIGNS

Fig. 4F

(57) **Abstract:** Modular IOL systems including a base (55) and a lens (65), wherein the lens includes fixed (95) and actuable tabs (96) for connection to the base. The modular IOL allows for the lens to be adjusted or exchanged while leaving the base in place, either intra-operatively or postoperatively. Drug delivery capabilities and/or sensing capabilities may be incorporated into the base. Injector devices may be used to facilitate placement of the base and the lens sequentially or simultaneously into the eye.

**WO 2016/122805 A1** 

---

**Published:**

— *with international search report (Art. 21(3))*

**MODULAR INTRAOCULAR LENS DESIGNS****CROSS-REFERENCE TO RELATED APPLICATIONS**

[001] This application claims the benefits under 35 U.S.C. § 119(e) of priority to U.S. Provisional Patent Application No. 62/110,241, filed January 30, 2015, entitled “MODULAR INTRAOCULAR LENS DESIGNS, TOOLS AND METHODS,” which is incorporated herein by reference. This application also claims the benefit of priority to U.S. Patent Application No. 14/828,083, filed August 17, 2015, entitled “MODULAR INTRAOCULAR LENS DESIGNS, TOOLS AND METHODS,” which is incorporated herein by reference, and which also claims the benefits under 35 U.S.C. § 119(e) of priority to U.S. Provisional Patent Application No. 62/110,241, filed January 30, 2015. This application is related to U.S. Patent Application No. 14/808,022, filed July 24, 2015, entitled “MODULAR INTRAOCULAR LENS DESIGNS AND METHODS,” which is incorporated herein by reference. This application also is related to U.S. Patent Application No. 14/610,360, filed January 30, 2015, entitled “MODULAR INTRAOCULAR LENS DESIGNS, TOOLS AND METHODS,” which claims the benefits under 35 U.S.C. § 119(e) of priority to U.S. Provisional Patent Application No. 61/941,167, filed February 18, 2014, entitled “MODULAR INTRAOCULAR LENS DESIGNS, TOOLS AND METHODS,” each of which is incorporated herein by reference. This application also is related to U.S. Patent Application No. 13/969,115, filed August 16, 2013, entitled “MODULAR INTRAOCULAR LENS DESIGNS & METHODS,” which claims the benefits under 35 U.S.C. § 119(e) of priority to U.S. Provisional Patent Application No. 61/830,491, filed June 3, 2013, entitled “MODULAR INTRAOCULAR LENS DESIGNS AND METHODS,” each of which is incorporated herein by reference. This application also is related to U.S. Patent Application No. 13/937,761, filed July 9, 2013, entitled “MODULAR INTRAOCULAR LENS DESIGNS

AND METHODS,” which is incorporated herein by reference. This application also is related to U.S. Patent Application No. 13/748,207, filed January 23, 2013, entitled “MODULAR INTRAOCULAR LENS DESIGNS & METHODS,” now U.S. Patent No. 9,095,424, which claims the benefits under 35 U.S.C. § 119(e) of priority of U.S. Provisional Patent Application No. 61/589,981, filed on January 24, 2012, entitled “LASER ETCHING OF IN SITU INTRAOCULAR LENS AND SUCCESSIVE SECONDARY LENS IMPLANTATION,” and of U.S. Provisional Patent Application No. 61/677,213, filed on July 30, 2012, entitled “MODULAR INTRAOCULAR LENS DESIGNS & METHODS,” each of which is incorporated herein by reference.

#### TECHNICAL FIELD

[002] The present disclosure generally relates to intraocular lenses (IOLs). More specifically, the present disclosure relates to embodiments of modular IOL designs, methods and associated tools.

#### BACKGROUND

[003] The human eye functions to provide vision by transmitting light through a clear outer portion called the cornea, and focusing the image by way of a crystalline lens onto a retina. The quality of the focused image depends on many factors including the size and shape of the eye, and the transparency of the cornea and the lens.

[004] When age or disease causes the lens to become less transparent (e.g., cloudy), vision deteriorates because of the diminished light, which can be transmitted to the retina. This deficiency in the lens of the eye is medically known as a cataract. An accepted treatment for this condition is surgical removal of the lens from the capsular bag and placement of an artificial intraocular lens (IOL) in the capsular bag. In the United

States, the majority of cataractous lenses are removed by a surgical technique called phacoemulsification. During this procedure, an opening (capsulorhexis) is made in the anterior side of the capsular bag and a thin phacoemulsification-cutting tip is inserted into the diseased lens and vibrated ultrasonically. The vibrating cutting tip liquefies or emulsifies the lens so that the lens may be aspirated out of the capsular bag. The diseased lens, once removed, is replaced by an IOL.

[005] After cataract surgery to implant an IOL, the optical result may be suboptimal or may need adjustment over time. For example, shortly after the procedure, it may be determined that the refractive correction is erroneous leading to what is sometimes called “refractive surprise.” Also for example, long after the procedure, it may be determined that the patient needs or desires a different correction, such as a stronger refractive correction, an astigmatism correction, or a multifocal correction.

[006] In each of these cases, a surgeon may be reluctant to attempt removal of the suboptimal IOL from the capsular bag and replacement with a new IOL. In general, manipulation of the capsular bag to remove an IOL risks damage to the capsular bag including posterior rupture. This risk increases over time as the capsular bag collapses around the IOL and tissue ingrowth surrounds the haptics of the IOL. Thus, it would be desirable to be able to correct or modify the optical result without the need to remove the IOL or manipulate the capsular bag.

[007] Thus, there remains a need for an IOL system and method that allows for correction or modification of the optical result using a lens that can be attached to a base or primary lens without the need to manipulate the capsular bag.

## SUMMARY OF THE DISCLOSURE

[008] Embodiments of the present disclosure provide a modular IOL system including intraocular base and optic components, which, when combined, form a modular IOL. In general, the modular IOL allows for the lens to be adjusted or exchanged while leaving the base in place, either intra-operatively or post-operatively.

[009] In one embodiment, a modular IOL system includes an annular base having two radially outward extending haptics. The base defines a center hole and an inside perimeter, with a radially inward open recess around the inside perimeter. The modular IOL system also includes a lens having an optical body with first and second tabs extending radially outward from the optical body. The base and lens may be assembled with the first and second tabs of the lens disposed in the recess of the base. The first tab may be an actuatable spring, and the second tab may be a non-actuatable extension. The first tab may require radial compression for assembly of the lens with the base. The first tab may comprise a pair of cantilever springs, each with one end attached to the optical body and one end free.

[010] Drug delivery capabilities and/or sensing capabilities may be incorporated into the base, which offers several advantages over incorporating such capabilities into the lens. For example, it avoids any interference the drugs or sensors may have with the optical performance of the lens.

[011] Embodiments of the present disclosure also provide injector devices that facilitate series or parallel delivery of the base and lens of the modular IOL. The injector may include a barrel having at least one internal lumen with at least one plunger disposed therein. After the base and the lens are both loaded into the barrel, the distal end of the barrel is placed into the eye and the plunger is advanced in the barrel to place the base and the lens into the eye. The base and the lens may be placed into the eye sequentially or

simultaneously. The barrel may include a single internal lumen with a single plunger disposed therein, two side-by-side internal lumens that merge distally with a plunger disposed in each lumen, or a single internal lumen with a pair of co-axial plungers disposed therein, for example. The base and lens may be placed in the barrel in-line or side-by-side, using cartridges if desired.

[012] The modular IOL systems, tools and methods according to embodiments of the present disclosure may be applied to a variety of IOL types, including fixed monofocal, multifocal, toric, accommodative, and combinations thereof. In addition, the modular IOL systems, tools and methods according to embodiments of the present disclosure may be used to treat, for example: cataracts, large optical errors in myopic (near-sighted), hyperopic (far-sighted), and astigmatic eyes, ectopia lentis, aphakia, pseudophakia, and nuclear sclerosis.

[013] Various other aspects of embodiments of the present disclosure are described in the following detailed description and drawings.

#### BRIEF DESCRIPTION OF THE DRAWINGS

[014] The drawings illustrate example embodiments of the present disclosure. The drawings are not necessarily to scale, may include similar elements that are numbered the same, and may include dimensions (in millimeters) and angles (in degrees) by way of example, not necessarily limitation. In the drawings:

[015] Figure 1 is a schematic diagram of the human eye shown in cross section;

[016] Figures 2A-2F are various views of a modular IOL according to the present disclosure;

[017] Figures 3A-3F are various views of an alternative base portion of a modular IOL according to the present disclosure;

[018] Figures 4A-4G show an example method of how a modular IOL may be implanted and removed;

[019] Figures 5A-5D are side schematic views of alternative series or parallel devices for implanting a modular IOL into the eye;

[020] Figures 6A-6C are various views of another alternative base portion of a modular IOL according to the present disclosure;

[021] Figures 7A-7C are perspective and top views of an alternative lens portion of a modular IOL according to the present disclosure;

[022] Figures 8A and 8B are perspective and top views of another alternative lens portion of a modular IOL according to the present disclosure;

[023] Figure 9 is a schematic top view of an alternative lens portion of a modular IOL incorporating drug delivery capabilities according to the present disclosure; and

[024] Figure 10 is a schematic top view of an alternative lens portion of a modular IOL incorporating sensor capabilities according to the present disclosure.

#### DETAILED DESCRIPTION

[025] With reference to Figure 1, the human eye 10 is shown in cross section. The eye 10 has been described as an organ that reacts to light for several purposes. As a conscious sense organ, the eye allows vision. Rod and cone cells in the retina 24 allow conscious light perception and vision including color differentiation and the perception of depth. In addition, the human eye's non-image-forming photosensitive ganglion cells in the retina 24 receive light signals which affect adjustment of the size of the pupil, regulation and suppression of the hormone melatonin, and entrainment of the body clock.

[026] The eye 10 is not properly a sphere; rather it is a fused two-piece unit. The smaller frontal unit, more curved, called the cornea 12 is linked to the larger unit called

the sclera 14. The corneal segment 12 is typically about 8 mm (0.3 in) in radius. The sclera 14 constitutes the remaining five-sixths; its radius is typically about 12 mm. The cornea 12 and sclera 14 are connected by a ring called the limbus. The iris 16, the color of the eye, and its black center, the pupil, are seen instead of the cornea 12 due to the cornea's 12 transparency. To see inside the eye 10, an ophthalmoscope is needed, since light is not reflected out. The fundus (area opposite the pupil), which includes the macula 28, shows the characteristic pale optic disk (papilla), where vessels entering the eye pass across and optic nerve fibers 18 depart the globe.

[027] Thus, the eye 10 is made up of three coats, enclosing three transparent structures. The outermost layer is composed of the cornea 12 and sclera 14. The middle layer consists of the choroid 20, ciliary body 22, and iris 16. The innermost layer is the retina 24, which gets its circulation from the vessels of the choroid 20 as well as the retinal vessels, which can be seen within an ophthalmoscope. Within these coats are the aqueous humor, the vitreous body 26, and the flexible lens 30. The aqueous humor is a clear fluid that is contained in two areas: the anterior chamber between the cornea 12 and the iris 16 and the exposed area of the lens 30; and the posterior chamber, between the iris 16 and the lens 30. The lens 30 is suspended to the ciliary body 22 by the suspensory ciliary ligament 32 (Zonule of Zinn), made up of fine transparent fibers. The vitreous body 26 is a clear jelly that is much larger than the aqueous humor.

[028] The crystalline lens 30 is a transparent, biconvex structure in the eye that, along with the cornea 12, helps to refract light to be focused on the retina 24. The lens 30, by changing its shape, functions to change the focal distance of the eye so that it can focus on objects at various distances, thus allowing a sharp real image of the object of interest to be formed on the retina 24. This adjustment of the lens 30 is known as

accommodation, and is similar to the focusing of a photographic camera via movement of its lenses.

[029] The lens has three main parts: the lens capsule, the lens epithelium, and the lens fibers. The lens capsule forms the outermost layer of the lens and the lens fibers form the bulk of the interior of the lens. The cells of the lens epithelium, located between the lens capsule and the outermost layer of lens fibers, are found predominantly on the anterior side of the lens but extend posteriorly just beyond the equator.

[030] The lens capsule is a smooth, transparent basement membrane that completely surrounds the lens. The capsule is elastic and is composed of collagen. It is synthesized by the lens epithelium and its main components are Type IV collagen and sulfated glycosaminoglycans (GAGs). The capsule is very elastic and so causes the lens to assume a more globular shape when not under the tension of the zonular fibers, which connect the lens capsule to the ciliary body 22. The capsule varies between approximately 2-28 micrometers in thickness, being thickest near the equator and thinnest near the posterior pole. The lens capsule may be involved with the higher anterior curvature than posterior of the lens.

[031] Various diseases and disorders of the lens 30 may be treated with an IOL. By way of example, not necessarily limitation, a modular IOL according to embodiments of the present disclosure may be used to treat cataracts, large optical errors in myopic (near-sighted), hyperopic (far-sighted), and astigmatic eyes, ectopia lentis, aphakia, pseudophakia, and nuclear sclerosis. However, for purposes of description, the modular IOL embodiments of the present disclosure are described with reference to cataracts.

[032] The following detailed description describes various embodiments of a modular IOL system including primary and secondary intraocular components, namely an intraocular base configured to releasably receive an intraocular optic. Features described

with reference to any one embodiment may be applied to and incorporated into other embodiments.

[033] With reference to Figures 2A-2F, an embodiment of a modular IOL 90, comprising a base 55 and a lens 65, is shown schematically. Figures 2A-2C show the base portion 55 of the modular IOL 90, and Figures 2D-2F show the optic or lens portion 65 of the modular IOL 90. Specifically, Figure 2A shows a front view of the base 55, Figure 2B shows a cross-sectional view taken along line B-B in Figure 2A, and Figure 2C shows a perspective view of the base 55. Figure 2D shows a front view of the lens 65, Figure 2E shows a cross-sectional view taken along line E-E in Figure 2D, and Figure 2F shows a perspective view of the lens 65. Modular IOL 90 may have dimensions as shown in the drawings by way of example, not necessarily limitation.

[034] With specific reference to Figures 2A-2C, the base 55 portion of the modular IOL 20 includes a pair of haptics 54 and a center hole 57 such that, except for the outermost portion, the posterior optical surface of the lens 65 is not in contact with the base 55 when the lens 65 is attached to the base 55. A recessed groove 92, which is sized and configured to receive tab portions 95 and 96 of the lens 65, defines the perimeter of the hole 57.

[035] Recessed groove 92 includes a lower rim 91, an upper rim 93 and an inward-facing lateral wall 94. The upper rim 93 may have an inside diameter that is the same as or greater than the outside diameter of the optic portion 97 of the lens 65 (excluding tabs 95 and 96) such that the lens 65 can rest inside the hole 57 of the base 55. All or a portion of the lower rim 91 may have an inside diameter that is less than the outside diameter of the lens 65 (including tabs 95 and 96) such that the lower rim 91 acts as a ledge or backstop for the lens 65 when placed in the hole 57 of the base 55. By way of example, not necessarily limitation, the upper rim 93 may have an inside diameter of

about 6.0 mm, the lower rim 91 may have an inside diameter of about 5.5 mm, the optic portion 97 of lens 65 may have an outside diameter of about 5.8 mm, and the tabs 95 and 96 may have a diameter or dimension of about 7.125 mm from the apex of tab 95 to the apex of tab 96.

[036] The lower 91 and upper 93 rims defining the groove 92 may extend continuously around all or a portion of the perimeter of the hole 57. The base 55 may be cryo-machined in two parts, including lower or posterior portion 55-1 and upper or anterior portion 55-2, that are subsequently bonded (e.g., adhesive or solvent bond), which may lend itself well to defining a continuous groove 92. To maintain chemical and mechanical property compatibility, the adhesive and the parts 55-1 and 55-2 of the base 55 may comprise the same monomeric or polymeric formulation. For example, the adhesive may be formulated from the same acrylic monomers used in making the hydrophobic acrylic parts 55-1 and 55-2 of the base 55. Alternatively, the lower 91 and upper 93 rims defining the groove 92 may extend discontinuously around all or a portion of the perimeter of the hole 57. An example of a discontinuous arrangement is alternating segments of the lower 91 and upper 93 rims, which may lend itself well to cryo-machining the base 55 in a single part. Alternative manufacturing methods well known in the art may also be employed.

[037] Optionally, the base posterior portion 55-1 may be a solid disc, rather than an annular ring with a hole 57, thereby defining a posterior surface against which the posterior side of the lens 65 would contact. The posterior surface may be flat or curved to conform to the posterior contour of the lens 65. This may have the advantage of providing a backstop for the lens 65 thereby making delivery and positioning of the lens 65 in the base 55 easier. This may also provide the advantage of reducing the rate of posterior capsular opacification.

[038] With specific reference to Figures 2D-2F, the lens 65 of the modular IOL 90 includes an optic portion 97 and one or more tabs 95 and 96. As shown, tab 95 is fixed, whereas tab 96 may be actuated. As an alternative, fixed tab 95 may be replaced with an actuable tab (e.g., like tab 96). Fixed tab 95 may include a thru hole 98 so that a probe or similar device may be used to engage the hole 98 and manipulate the tab 95. Actuable tab 96 may be actuated between a compressed position for delivery into the hole 57 of the base 55, and an uncompressed extended position (shown) for deployment into the groove 92 of the base 55, thus forming an interlocking connection between the base 55 and the lens 65.

[039] The outside curvature of the fixed tab 95 may have a radius conforming to the inside radius of the groove 92. Similarly, the outside curvature of the actuable tab 96 may have a radius that conforms to the inside radius of the groove 92 when the actuable tab 96 is in its uncompressed extended position. This arrangement limits relative movement between the base 55 and the lens 65 once connected.

[040] Optionally, the lens 65 may be oval or ellipsoidal, rather than circular, with the tabs 95 and 96 positioned adjacent the long axis. This arrangement would thus define a gap between the edge of the lens 65 along its short axis and the inside perimeter of the upper rim 93 of the groove 92 in the base 55. The gap may have the advantage of providing access for a probe or similar device to pry apart the lens 65 from the base 55 if separation were needed.

[041] Actuable tab 96 may be attached to and extend from the lens 65 at two ends with the middle portion free of the lens 65 (like a leaf spring) as shown. Alternatively, actuable tab 96 may be attached to and extend from the lens 65 at one end with the other end free (like a cantilever spring). Other spring configurations may be employed as known in the mechanical arts.

[042] The actuatable tab 96 may elastically deform (e.g., by application of an inward lateral force) to its compressed position. To facilitate low force compression, a dimple 99 may be provided on the outside (and/or inside) curvature of the tab to form a hinge in the spring.

[043] Figures 3A-3F show an alternative base portion 55A of the modular IOL 90. Specifically, Figure 3A shows a front view of the base 55A, Figure 3B shows a cross-sectional view taken along line B-B in Figure 3A, Figure 3C shows a perspective view of the base 55A, Figure 3D shows a detail view of circle D in Figure 3B, Figure 3E shows a detail view of circle E in Figure 3A, and Figure 3F shows a perspective view of the assembled modular IOL 90 including base 55A and lens 65. In this alternative embodiment, all aspects of the base 55A of the modular IOL 90 are substantially the same except for the provision of a pair of cutouts 91A, a pair of notches 93A, an outer rim 53, and sharp edges 91B and 91C. All similar aspects of the prior embodiment are incorporated by reference into the description of this embodiment. Also, dimensions are provided by way of example, not necessarily limitation.

[044] As in the prior embodiment, the base 55A portion of the modular IOL 90 in this alternative embodiment includes a pair of haptics 54 and a center hole 57 such that, except for the outermost portion, the posterior optical surface of the lens 65 is not in contact with the base 55A when the lens 65 is attached to the base 55A. Also as in the prior embodiment, the base 55A may be formed as a single piece, or formed as a posterior portion 55A-1 and an anterior portion 55A-2 that are fixed to each other by adhesive or the like (as shown). A recessed groove 92, which is sized and configured to receive tab portions 95 and 96 of the lens 65, defines the perimeter of the hole 57. The recessed groove 92 includes a lower rim 91, an upper rim 93 and an inward-facing lateral wall 94.

The lower rim 91 may be part of the posterior portion 55A-1 of the base 55A, and the upper rim may be part of the anterior portion 55A-2 of the base 55A

[045] In this alternative embodiment of the base 55A of modular IOL 90, the lower rim 91 may include one or more cutouts 91A, which aid in removing visco-elastic intra-operatively. Also in this alternative embodiment, the upper rim 93 may include one or more notches 93A to provide access for a Sinsky hook intra-operatively, which allows the base 55A to be more easily manipulated.

[046] Further in this embodiment, the base 55A may include an outer rim 53 extending around substantially the entire periphery of the base 55A. The outer rim 53 may be formed as a part of the posterior portion 55A-1 of the base 55A as shown, or as a part of the anterior portion 55A-2 of the base. At the junction of the haptic 54, the outer rim 53 may terminate short of the inside curvature of the haptic 54 to provide a flexible junction of the haptic 54 to the body of the base 55A, and the outer rim 53 may extend continuously with the outside curvature of the haptic 54.

[047] The posterior-most side of base 55A may include at least one corner edge 91B along its perimeter, and the outside perimeter of the body of the base 55A may include corner edges 91C and 91D, all to reduce the tendency for posterior capsular opacification. In addition, an anterior corner edge 93B may be formed along the anterior perimeter of the base 55A. The corner edges 91B, 91C and 91D may be formed into the posterior portion 55A-1 of the base 55A defining lower rim 91, and the corner edge 93B may be formed into the anterior portion 55A-2 of the base 55A defining upper rim 93. In cross-section, the corner edges 91B, 91C, 91D and 93B may be defined by a square angle, an acute angle, or an obtuse angle. The posterior corner edge 91B may be flush with the posterior surface as shown, or may protrude posteriorly. The base 55A may be machined without subsequent tumbling to better form the corner edges 91B, 91C, 91D and 93B.

Preferably, the corner edges 91B, 91C, 91D and 93B may extend around the entire circumference of the base 55A.

[048] Note with reference to Figures 2B, 3B and 2E that the lower rim 91 and the upper rim 93 may define an anterior-posterior (AP) dimension around the perimeter of the base 55/55A that is greater than the corresponding AP dimension of the lens 65 adjacent the tabs 95 and 96 that fit into groove 92. For example, the AP dimension of the perimeter of the base 55/55A may be 0.615 mm as shown in Figures 2B and 3B, and the corresponding AP dimension of the lens 65 adjacent the tabs 95, 96 may be 0.25 mm as shown in Figure 2E. When the modular IOL 90 is implanted in the capsular bag, these relative dimensions provide a standoff between the posterior capsule and the posterior side of the lens 65, as well as a standoff between the anterior capsule adjacent the capsulorhexis (sometimes call anterior leaflets) and the anterior side of the optic. This standoff reduces the likelihood of cellular proliferation and the potential for resulting opacification of the lens 65 and/or tissue adhesion to the lens 65 that might otherwise interfere with post-operative optic exchange. Because such cellular proliferation typically grows radially inward, the standoff may be provided adjacent the perimeter of the lens 65 adjacent the inside circumference of the lower and upper rims 91, 93, whereas the center of the optic may or may not have a standoff, with an AP dimension that is less than, the same as or greater than the AP dimension around the perimeter of the base 55/55A. For example, the center of the optic may have an AP dimension of 0.78 mm as shown in Figure 2E (depending on the diopter), which is greater than the AP dimension of the perimeter of the base 55/55A at 0.615 mm as shown in Figures 2B and 3B. Additionally, the lower (posterior) rim 91 may have a greater AP dimension than the upper (anterior) rim 93 recognizing the cellular proliferation may be more likely on the posterior side than the anterior side due to the presence of the capsulorhexis on the anterior side and the

corresponding lower tissue contact area on the anterior side. Those skilled in the art will recognize the importance of the relative dimensions to achieve this effect rather than the specific dimensions, which are provided by way of example, not necessarily limitation.

[049] By way of example, not necessarily limitation, the following dimensions are provided with reference to alternative base 55A illustrated in Figures 3A-3E. In Figure 3A, diameter A1 may be  $13.00 \pm 0.02$  mm, diameter A2 may be  $8.50 \pm 0.10$  mm, diameter A3 may be  $7.00 \pm 0.051$  mm, diameter A4 may be  $6.30 \pm 0.051$  mm, diameter A5 may be  $5.50 +0.15/-0.05$  mm, and diameter A6 may be 7.92 mm. In Figure 3B, dimension B1 may be  $0.615 \pm 0.020$  mm. In Figure 3D, dimension D1 may be 0.15 mm, dimension D2 may be 0.17 mm, dimension D3 may be 0.75 mm, dimension D4 may be 0.35 mm, dimension D5 may be 0.08 mm, and dimension D6 may be  $0.30 \pm 0.02$  mm. In Figure 3E, dimension E1 (width of cutouts 91A) may be 1.48 mm, dimension E2 (diameter at outer edge of notches 93A) may be 6.62 mm, dimension E3 (inside diameter of upper rim 93) may be 6.25 mm, and dimension E4 (radian of cutouts 91A) may be 30 degrees.

[050] In general, the modular IOL 90 allows for the lens 65 to be adjusted or exchanged while leaving the base 55 in place, either intra-operatively or post-operatively. Examples of instances where this may be desirable include, without limitation: exchanging the lens 65 for a suboptimal refractive result detected intra-operatively; exchanging the lens 65 for a suboptimal refractive result detected post-operatively (residual refractive error); rotationally adjusting the lens 65 relative to the base 55 to fine tune toric correction; laterally adjusting the lens 65 relative to the base 55 for alignment of the optic with the true optical axis (which may not be the center of the capsular bag); and exchanging the lens 65 for the changing optical needs or desires of the patient over longer periods of time. Examples of the latter instance include, but are not limited to: an

adult or pediatric IOL patient whose original optical correction needs to be changed as s/he matures; a patient who wants to upgrade from a monofocal IOL to a premium IOL (toric, multifocal, accommodating or other future lens technology); a patient who is not satisfied with their premium IOL and wants to downgrade to monofocal IOL; and a patient who develops a medical condition where an IOL or a particular type of IOL is contra-indicated.

[051] An example of how the modular IOL 90, including base 55 and lens 65, may be implanted is shown in Figures 4A-4D. An example of how the lens 65 may be removed from the base 55 is shown in Figures 4E-4G. After the lens 65 is removed from the base 55 (and the eye), a different lens 65 may be implanted in the same base 55 following the steps described with reference to Figures 4C-4D.

[052] As shown in Figure 4A, the modular IOL 90 may be implanted by initially delivering the base 55 into the capsular bag in a rolled configuration using an injector (a.k.a., inserter or delivery tube) inserted through a corneal incision 13, through the capsulorhexis 36, and into the capsular bag 34. As shown in Figure 4B, the base 55 may be ejected from the injector and allowed to unfurl. With gentle manipulation, the haptics 54 of the base 55 engage the inside equator of the lens capsule 34 and center the hole 57 of the base 55 relative to the capsulorhexis 36.

[053] The lens 65 may also be delivered in a rolled configuration using an injector, positioning the distal tip thereof adjacent the base 55. The lens 65 may be ejected from the injector and allowed to unfurl. With gentle manipulation, the lens 65 is centered relative to the capsulorhexis 36. Once the base 55 has been delivered and unfurled in the capsular bag, the lens 65 may be connected to the base 55 via placing tabs 95 and 96 into groove 92 to provide an interlocking connection between the base 55 and the lens 65.

[054] As shown in Figures 4C-4D, the lens 65 may be connected to the base 55 by first inserting the actuatable tab 96 into the groove 92. The actuatable tab 96 may then be compressed by application of a lateral force using a probe or similar device inserted into hole 98 of fixed tab 95, allowing the lens 65 to be advanced into the hole 57 of the base 55 such that the lens 65 and base 55 are coplanar.

[055] The compressive force may then be released from the actuatable tab 96, allowing the fixed tab 95 to slide into the groove 92 of the base 55, thus connecting the lens 65 to the base 55. By using a lateral force to compress the interlocking feature rather than an anterior-posterior force, the risk of posterior rupture of the capsular bag is reduced. The probe may be removed from hole 98. Reverse steps may be followed to disconnect the lens 65 from the base 55.

[056] The actuatable tab 96 and groove 92 may be described as interlocking members that provide an interlocking connection between the base 55 and the lens 65, wherein at least one of the pair of interlocking members is actuatable to lock or unlock the connection therebetween. More generally, one or more interlocking connections may be provided between the base and lens. Each interlocking connection may include a pair of interlocking members, wherein one or both of the interlocking members are actuatable. The actuatable interlocking member may be associated with the lens as described with reference to modular IOL 90 in Figures 2A-2F.

[057] As shown in Figures 4E-4G, lens removal begins by disengaging a lens 65 from a base 55. As shown in Figure 4E, a probe or similar device may pass through the corneal incision 13, capsulorhexis 36, and enter the capsular bag 34 containing a modular IOL, for example modular IOL 90. As shown in Figure 4F, the probe or similar device may engage the hole 98 of fixed tab 95 and compress the actuatable tab 96 by application of a lateral force. Upon compression, fixed tab 95 may separate from groove 92 of the

base 55. With gentle manipulation, the lens 65 may be lifted such that the lens 65 and base 55 are no longer coplanar. Once freed, the compressive force may then be released and the actuatable tab 96 may elastically expand and separate from the groove 92 of the base 55.

[058] As shown in Figure 4G, the probe or similar device may be used to pass the lens 65 from the capsular bag 34 into the anterior chamber 15. This step does not damage the eye or expand the size of the capsulorhexis 36 because the width of the lens 65 is less than the width of the capsulorhexis 36. The probe or similar device may also rotate the lens 65 into an orientation where the fixed tab 95 is proximal to the corneal incision 13 and the actuatable tab 96 is distal to the corneal incision 13.

[059] A typical corneal incision 13 may have a width of about 2.2 mm, less than the outer diameter of the lens 65. Removing the lens 65 from the anterior chamber 15 through the corneal incision 13 may thus require mechanical manipulation of the lens 65. The lens 65 may be manipulated, for example cut, such that it can be pulled through the corneal incision, either as a single piece or in multiple pieces. A cannula or tube may be used to facilitate this removal.

[060] A conventional injector (a.k.a., inserter) may be used to deliver the base 55 and lens 65. Examples of suitable injectors are described in U.S. Patent Nos. 5,123,905 to Kelman, 4,681,102 to Bartell, 5,304,182 to Rheinisch, and 5,944,725 to Ciconas. Such injectors may be configured to deliver the base 55 and lens 65 singly as described with reference to Figures 4A-4G. Alternatively, the base 55 and lens 65 may be loaded into an injector in-line for delivery in series (i.e., sequentially) or loaded pre-assembled for delivery in parallel (i.e., simultaneously). Examples of alternative injector configurations that facilitate series or parallel delivery are shown in Figures 5A – 5D.

[061] With reference to Figure 5A, alternative injector 100 includes a tubular barrel 102 having a single internal lumen with a plunger 104 disposed therein. The distal end 106 of the barrel 102 is tapered for insertion into a corneal incision. A pair of in-line cartridges 108A and 108B are disposed in the barrel 102 and are configured to hold the base 55 and lens 65, respectively, in a rolled configuration (not visible). Cartridges 108A and 108B may be configured as disclosed in Bartell '102 mentioned above, except that two in-line cartridges are provided instead of one. As an alternative to cartridges 108A and 108B, the base 55 and lens 65 may be pre-disposed in the barrel 102 or placed in the barrel 102 through a side-load opening as described by Kelman '905 mentioned above. Optionally, a spacer 107 may be disposed between the cartridges 108A and 108B inside the barrel 102. Upon advancement of the plunger 104 inside the barrel 102, the distal end of the plunger 104 pushes the lens 65 out of cartridge 108B which, in turn, pushes the spacer 107 (if used) to engage the base 55 disposed in cartridge 108A. Continued advancement of the plunger 104 pushes the base 55 out of the distal end 106 of the injector 100 and into the eye, followed by the lens 65. The lens 65 may then be attached to the base 55 inside the eye. The spacer 107 may be tethered to the injector to avoid implantation in the eye, or it may be formed of a dissolvable material that can be left in the eye. The base 55 may have a lower volume than lens 65 (i.e., less material) such that the force required to advance the base 55 in the barrel 102 is lower than the force required to advance the lens 65 in the barrel 102, thus reducing the tendency of the lens 65 to jam inside the barrel 102 as it pushes against the base 55.

[062] With reference to Figure 5B, another alternative injector 110 includes a tubular barrel 102 having two side-by-side internal lumens separated by internal wall 103, with a pair of plungers 104A and 104B disposed therein. The distal end 106 of the barrel 102 includes a common single lumen where the two side-by-side lumens merge and the

wall 103 terminates. The distal end 106 of the barrel 102 is tapered for insertion into a corneal incision. A pair of side-by-side cartridges 108A and 108B are disposed in the barrel 102 and are configured to hold the base 55 and lens 65, respectively, in a rolled configuration (not visible) in each of the side-by-side lumens. Cartridges 108A and 108B may be configured as disclosed in Bartell '102 mentioned above, except that two side-by-side cartridges are provided instead of one. As an alternative to cartridges 108A and 108B, the base 55 and lens 65 may be pre-disposed in the barrel 102 or placed in the barrel 102 through side-load openings as described by Kelman '905 mentioned above. Upon advancement of the plunger 104A inside the barrel 102, the distal end of the plunger 104A pushes the base 55 out of cartridge 108A, out of the distal end 106 of the injector 100 and into the eye. Plunger 104A may then be retracted into its original position. Subsequently, plunger 104B may be advanced inside the barrel 102 to push the lens 65 out of cartridge 108B, out of the distal end 106 of the injector 100 and into the eye. The lens 65 may then be attached to the base 55 inside the eye.

[063] With reference to Figure 5C, another alternative injector 120 includes a tubular barrel 102 having a single internal lumen with a pair of co-axial plungers 104C and 104D disposed therein. The inner plunger 104C is configured to be axially movable inside outer tubular plunger 104D. The distal end 106 of the barrel 102 is tapered for insertion into a corneal incision. A pair of in-line cartridges 108A and 108B are disposed in the barrel 102 and are configured to hold the base 55 and lens 65, respectively, in a rolled configuration (not visible). Cartridges 108A and 108B may be configured as disclosed in Bartell '102 mentioned above, except that two in-line cartridges are provided instead of one. As an alternative to cartridges 108A and 108B, the base 55 and lens 65 may be pre-disposed in the barrel 102 or placed in the barrel 102 through a side-load opening as described by Kelman '905 mentioned above. The lens 65 may be rolled about

the shaft of the inner plunger 104C allowing the inner plunger 104C to slide therethrough. Upon advancement of the inner plunger 104C inside the outer plunger 104D and barrel 102, the distal end of the inner plunger 104C pushes the base 55 out of cartridge 108A. Continued advancement of the inner plunger 104C causes the distal end thereof to push the base 55 out of the distal end 106 of the injector 100 and into the eye. The inner plunger 104C may then be retracted to its original position. Upon subsequent advancement of the outer plunger 104D over the inner plunger 104C, the distal end of the outer plunger 104D pushes the lens 65 out of the cartridge 108B. Continued advancement of the outer plunger 104D pushes the lens 65 off the distal end of the inner plunger 104C, out of the distal end 106 of the injector 100 and into the eye. The lens 65 may then be attached to the base 55 inside the eye.

[064] With reference to Figure 5D, another alternative injector 130 includes a tubular barrel 102 having a single internal lumen with a plunger 104 disposed therein. The distal end 106 of the barrel 102 is tapered for insertion into a corneal incision. A pair of side-by-side cartridges 108A and 108B are disposed in lateral slot extensions 109A and 109B, respectively. Cartridges 108A and 108B are configured to hold the base 55 and lens 65, respectively, in a rolled configuration (not visible). Cartridges 108A and 108B may be configured as disclosed in Bartell '102 mentioned above, except that two side-by-side cartridges are provided instead of one. As an alternative to cartridges 108A and 108B, the base 55 and lens 65 may be pre-disposed in the barrel 102 or placed in the barrel 102 through side-load openings as described by Kelman '905 mentioned above.

[065] With continued reference to Figure 5D, the side-by-side cartridges 108A and 108B slide laterally inside the slot extensions 109A and 109B to align the base 55 contained in cartridge 108A with the lumen of the barrel 102 when pushed in a first position (down position as shown), and to align the lens 65 contained in cartridge 108B

with the lumen of the barrel 102 when pushed into a second position (up position, not shown). Initially, cartridge 108A containing base 55 is pushed into the slot extension 109A and into the barrel 102. Upon advancement of the plunger 104 inside the barrel 102, the distal end of the plunger 104 pushes the base 55 out of cartridge 108A, out of the distal end 106 of the injector 100 and into the eye. Plunger 104 may then be retracted into its original position (as shown). Subsequently, cartridge 108B is pushed into slot extension 109B and into the barrel 102, pushing empty cartridge 108A out of the barrel 102 and into slot extension 109A. Plunger 104 may then be advanced inside the barrel 102 to push the lens 65 out of cartridge 108B, out of the distal end 106 of the injector 100 and into the eye. The lens 65 may then be attached to the base 55 inside the eye. The cartridges 108A and 108B may be slid manually as described or may be automatically moved, for example, using a spring to bias to push cartridge 108B containing lens 65 into the barrel 102 when the plunger 104 is retracted after delivering the base 55 from cartridge 108A.

[066] As mentioned previously, the base 55 and lens 65 may be delivered in series or in parallel. For delivery in parallel, the lens 65 may be pre-assembled with the base 55, rolled together, and then loaded into an injector for delivery into the eye, thus negating the need to assemble the two inside the eye. A dissolvable adhesive, a severable member (e.g., a tab, tether or hinge severable by cutting or laser ablating) or other temporary connecting means may be used to maintain the assembled connection between the base 55 and lens 65 during the rolling, loading and delivery process. Alternatively, the lens 65 may be stacked onto the base 55 (without assembling the two), rolled together, loaded into an injector, delivered into the eye, and then assembled inside the eye.

[067] Figures 6A – 6C illustrate another alternative base 55B for use with the modular IOL 90. Figure 6A is a perspective view of the base 55B, Figure 6B is a top

(anterior) view of the base 55B, and Figure 6C is a perspective sectional view of the base 55B taken along line C-C in Figure 6B. Alternative base 55B is similar to base 55 except for the configuration of the groove 92 and the overall size of the base 55B. All similar aspects of the prior embodiment are incorporated by reference into the description of this embodiment.

[068] In this embodiment, the groove 92 is defined by an upper rim or wall 93 angled in an anterior direction, an inward-facing lateral wall 94, and a lower rim or wall 91 angled in a posterior direction. The upper rim 93 may be angled at 30 degrees, for example, anteriorly from the plane of the groove 92, and the lower rim 91 may be angled at 30 degrees, for example, posteriorly from the plane of the groove 92.

[069] The lateral wall 94 may have a height (anterior-posterior dimension) that matches the thickness of the tabs 95 and 96. The lateral wall 94 may have a linear geometry that matches the outer-most wall of the tabs 95 and 96. The lateral wall 94 may intersect the upper and lower rims 93 and 91 to form inside corners. Compared to a curved intersection, the inside corners may provide better anterior-posterior stability of the tabs 95 and 96 inside the groove 92, and thereby provide better anterior-posterior stability of the lens 65 relative to the base 55B.

[070] The opening of the groove 92 may have a dimension defined by the distance between the upper rim 93 and the lower rim 91 along the inside diameter of the rims 91 and 93. The opening dimension of the groove 92 may be substantially greater than the thickness of the tabs 95 and 96 to allow for easy insertion of the lens 65 into the base 55B. In one example, the opening dimension of the groove 92 is 1.5 times greater than the thickness of the tabs 95 and 96. In another example, the opening dimension of the groove 92 is 2.0 times greater than the thickness of the tabs 95 and 96. The large

opening of the groove 92 allows for faster and easier insertion of the lens 65 into the base 55B.

[071] Commercially available IOLs typically have an equatorial diameter (excluding haptics) of about 6mm, an anterior-posterior thickness of about 0.2 mm at 6mm diameter and 0.7 mm at the center, providing an overall volume of about 12 mm<sup>3</sup>. Lens 65 is similarly dimensioned, but the base 55B adds substantially more volume. The base 55B may have an equatorial diameter (excluding haptics 54) of about 8.5 mm, an anterior-posterior thickness of about 1mm at 8.5 mm diameter, 2.5 mm at 6 mm diameter, providing an overall volume of about 67 mm<sup>3</sup> when the lens 65 is disposed in the base 55B. Thus, the size of the combined base 55B and lens 65 is volumetrically much larger than conventional IOLs available on the market. This relatively larger volume is intended to fill the capsular bag more like a natural lens, thus increasing the stability of the base 55B and reducing post-operative migration due to the bag collapsing around the base 55B. By way of comparison, a typical natural lens has an equatorial diameter of about 10.4 mm, an anterior-posterior dimension of about 4.0 mm for a corresponding volume of about 180 mm<sup>3</sup>. Due to anatomic variability, a natural lens may have a volume ranging from 130 mm<sup>3</sup> to 250 mm<sup>3</sup>. Thus, the base 55B plus the lens 65 consumes about 50% to 25% of the volume of the bag after the natural lens has been extricated, whereas a conventional IOL consumes about 10% to 5% of the volume of the bag.

[072] Figures 7A-7B illustrate an alternative lens 65A for use with the modular IOL 90. Figure 7A is a perspective view of the alternative lens 65A, and Figure 7B is a top (anterior) view of the lens 65A. Alternative lens 65A is similar in design and function as lens 65, except for a notch 98A provided in the fixed tab 95 and an alternative actuatable tab 96A. All similar aspects of the prior embodiment are incorporated by reference into the description of this embodiment.

[073] Specifically, alternative lens 65A includes an optic portion 97 and one or more fixed tabs 95 and one or more actuatable tabs 96A. Optionally, fixed tab 95 may be replaced with an actuatable tab (e.g., like tab 96A). Fixed tab 95 may include a thru hole 98 so that a probe or similar device may be used to engage the hole 98 and manipulate the tab 95. Fixed tab 95 may also include a notch 98A positioned counter-clockwise of the hole 98 (or otherwise on the counter-clockwise side of the tab 95) to provide an indication that the anterior side of the lens 65A is right side up when implanted. In other words, when the lens 65A is placed in the base 55, if the notch 98A is positioned counter-clockwise of the hole 98, then the anterior side of the lens 65A is correctly positioned facing anteriorly. If the notch 98A is positioned clockwise of the hole 98, then the anterior side of the lens 65A is incorrectly positioned facing posteriorly. Other indicators of correct anterior-posterior placement of the lens 65A may be employed by providing two markers about the periphery of the lens 65A and designating their correct relative position (clockwise or counter-clockwise).

[074] Actuatable tab 96A may be actuated between a compressed position for delivery into the hole 57 of the base 55, and an uncompressed extended position (shown) for deployment into the groove 92 of the base 55, thus forming an interlocking connection between the base 55 and the lens 65A. Actuatable tab 96A includes two members 96A1 and 96A2, each with one end connected to the peripheral rim 97A around optic 97, and the other end free, thus forming two cantilever springs. Compared to actuatable tab 96 (illustrated in Figures 2D-2F) which is attached at two ends to the periphery of the optic 97 and is joined in the middle like a single leaf spring, actuatable tab 96A includes two members 96A1 and 96A2 with each end attached to the peripheral rim 97A around the optic 97 and the other end free like two cantilever springs. A notch 96A3 may be formed in the peripheral rim 97A between the two members 96A1 and 96A2 to add hinge-like

flexibility to the two members 96A1 and 96A2 where they attach to the peripheral rim 97A. Notch 96A3 also provides access for a probe or similar device to manipulate the tab 96A into the groove 92 in the base 55.

[075] As shown in Figures 7A and 7B, the two cantilever members 96A1 and 96A2 of actuable tab 96A are attached at one end to the peripheral rim 97A around the optic 97 and extend radially outward and away from each other in an arc shape. In this configuration, and as compared to actuable tab 96 shown in Figures 2D-2F, the cantilever members 96A1 and 96A2 engage the lateral wall 94 defining the groove 92 in the base 55 at two spaced-apart portions. Together with fixed tab 95, which contacts a portion of the lateral wall 94 diametrically opposite, the lens 65A is connected to the base 55 at three spaced apart locations, thus providing additional relative planar stability.

[076] Optionally, one or both of the two cantilever members 96A1 and 96A2 may include a hole 96A4 as shown in Figure 7C. Hole 96A4 may be sized and configured to receive an intraocular tool such as a Sinsky hook, which may be used to rotate the lens 65A when disposed in the base 55. This allows for easy rotational adjustment of the lens 65A relative to the base 55, which may be useful in making adjustments in toric applications. Such a feature may be incorporated into any of the fixed or actuable tabs described herein.

[077] Figures 8A-8B illustrate yet another alternative lens 65B for use with the modular IOL 90. Figure 8A is a perspective view of the lens 65B, and Figure 8B is a top (anterior) view of the lens 65B. Alternative lens 65B is similar in design and function as lens 65A, except for an alternative actuable tab 96B, which includes two cantilever members 96B1 and 96B2. All similar aspects of the prior embodiment are incorporated by reference into the description of this embodiment. In this embodiment, the two cantilever members 96B1 and 96B2 of actuable tab 96B are attached at one end to the

peripheral rim 97A around the optic 97 and extend radially outward and toward each other (rather than away from each other) in an arc shape. This configuration is similar to the actuatable tab 96 shown in Figures 2D-2F except that the members 96B1 and 96B2 are disconnected, thus forming a pair of cantilever springs rather than a leaf spring.

[078] Optionally, drugs may be incorporated into or carried by the base 55.

Using the base 55 as a carrier for drugs, as opposed to the lens 65, has a number of advantages. For example, it avoids any interference the drug or drugs may have with the optical performance of the lens 65. Also, because the base 55 doesn't require tumbling as part of the manufacturing process like the lens 65 does, drugs carried by the base 55 aren't exposed to potential damage. Drugs may be incorporated into the base 55 by connecting one or more separate drug carriers to the base 55, having the material of the base 55 act as a carrier for the drug (e.g., like a sponge), incorporating one or more drug-eluting materials into the base 55, or incorporating one or more refillable reservoirs into the base 55 that carry the drug. One or multiple portions of the base 55 may carry the drug or drugs, and these portions may be separate from each other, to avoid interaction between different drugs, for example. The portion or portions of the base 55 carrying the drug may be selectively activated by light or thermal energy (e.g., laser, UV light, etc.) to release the stored drug or drugs all at once or in a series of releases over time.

[079] Examples of clinical indications for such drugs include wet or dry macular degeneration, open or close angle glaucoma, uveitis, posterior capsular opacification, post-op management after cataract surgery, etc. Examples of drugs that may be used for wet macular degeneration include aflibercept, bevacizumab, pegaptanib, ranibizumab, steroids, and aptamers. Examples of drugs that may be used for dry macular degeneration include complement factors, anti-oxidants and anti-inflammatory agents. Examples of drugs that may be used for open angle glaucoma include brimonidine, latanoprost,

timolol, pilocarpine, brinzolamide and other drugs in the general categories of beta blockers, alpha agonists, ROCK Inhibitors, adenosine receptor agonists, carbonic anhydrase inhibitors, adrenergic and cholinergic receptor activating agents, and prostaglandin analogues. Examples of drugs that may be used for uveitis include methotrexate, antibodies, dexamethasone, triamcinolone, and other steroid agents. Examples of drugs that may be used for posterior capsular opacification include anti-proliferative, anti-mitotic, anti-inflammatory, and other medications that would inhibit the spread of lens epithelial cells. Examples of drugs that may be used for post-op management after cataract surgery include antibiotics such as fluoroquinolones, non-steroidal agents such as ketorolacs, and steroids such as prednisolones. Other medications that may be used to treat various ocular diseases and conditions include: anti-fibrotic agents, antiinflammatory agents, immunosuppressant agents, anti-neoplastic agents, migration inhibitors, anti-proliferative agents, rapamycin, triamcinolone acetate, everolimus, tacrolimus, paclitaxel, actinomycin, azathioprine, dexamethasone, cyclosporine, bevacizumab, anti-VEGF agents, anti-IL-1 agents, canakinumab, anti-IL-2 agents, viral vectors, beta blockers, alpha agonists, muscarinic agents, steroids, antibiotics, non-steroidal antiinflammatory agents, prostaglandin analogues, ROCK inhibitors, nitric oxide, endothelin, matrixmetalloproteinase inhibitors, CNPA, corticosteroids, and antibody-based immunosuppressants. These drugs may be used individually or in combination, depending on the patient's particular clinical indication.

[080] Also, the portion or portions of the base 55 carrying the drug or drugs may face a particular direction or directions while other directions are masked or blocked to increase the concentration of the drug on a specific portion of the lens capsule. For example, posterior ocular structures may be the focus of drug delivery (e.g., to mitigate macular degeneration), and/or anterior ocular structures may be the focus of drug delivery

(e.g., to deliver glaucoma drugs adjacent the angle, to deliver drugs for uveitis or post-op management after cataract surgery).

[081] By way of example, Figure 9 shows a top (anterior) view of the base 55, which incorporates one or more drug carriers 50. As shown, the drug carriers 50 are spaced around the circumference of the anterior side of the body of the base 55. The drug carriers 50 may comprise a refillable reservoir (e.g., silicone vessel), an eluting porous material (e.g., biocompatible sponge), a biodegradable or bioerodable material (e.g., PLGA), etc. The reservoir may also be targeted to expose drugs to the aqueous environment through laser, UV light, RF signal, magnetic manipulation or other methods for remotely removing a barrier to diffusion. The carriers 50 may be placed on the surface of the base 55, or embedded, for example. To focus the delivery of drugs to a particular area of the eye, the carriers 50 may be exposed on one side (e.g., the anterior side as shown) while the material of the base 55 covers the other sides.

[082] Similarly, one or more microelectronic sensors may be incorporated into or carried by the base 55. Using the base 55 as a carrier for sensors, as opposed to the lens 65, has a number of advantages. For example, it avoids any interference the sensors may have with the optical performance of the lens 65. Also, because the base 55 doesn't require tumbling as part of the manufacturing process like the lens 65 does, sensors carried by the base 55 aren't exposed to potential damage.

[083] As shown in Figure 10 which is a top (anterior) view of a base 55, a sensor 70 may be attached or embedded in the base 55 in a manner similar to drug carrier 50 described with reference to Figure 9. The sensor 70 may be connected to an integrated control circuit 72, which is connected to an antenna 74. The control circuit 72 may include a transmitter or transceiver circuit to wirelessly transmit sensor data to an external device via antenna 74. The control circuit 72 may include a power circuit that receives

electrical power via an inductive link to an external power source. Examples of suitable sensors that may be incorporated into or carried by the base 55 include biological sensors such as a glucose sensor, an electrolyte sensor, a protein sensor, a temperature sensor, a conductivity sensor, an electric field sensor, a pressure sensor (e.g., for measuring intra-ocular pressure), a pulse oximeter sensor, or a photo sensor to support artificial vision. Examples of microelectronic sensors for use with contact lenses are described in U.S. Patent Application Publications 2014/0085599, 2014/0084489, 2014/0085602, and 2014/0087452, 2014/0085600, 2014/0088381, 2014/0192311, 2014/0194710, 2014/0194713, 2014/0194773, 2014/0098226 and 20140081178, and PCT Publication WO/2014/204575 which are incorporated herein by reference. Such microelectronic sensors for use with contact lenses may be hermetically sealed in the base 55 for implant applications in the eye. The sensor 70 may include a permeable cover for direct biological interface applications (glucose sensor, electrolyte sensor, protein sensor, etc.). Alternatively, the sensor 70 may include an impermeable cover for indirect biological interface applications (pressure sensor, temperature sensor, conductivity sensor, electric field sensor, etc.).

[084] The foregoing discussion of the disclosure has been presented for purposes of illustration and description. The foregoing is not intended to limit the disclosure to the form or forms disclosed herein. Although the disclosure has included description of one or more embodiments and certain variations and modifications, other variations and modifications are within the scope of the disclosure, e.g., as may be within the skill and knowledge of those in the art, after understanding the present disclosure. It is intended to obtain rights which include alternative embodiments to the extent permitted, including alternate, interchangeable and/or equivalent structures, functions, ranges or steps to those claimed, whether or not such alternate, interchangeable and/or equivalent structures,

functions, ranges or steps are disclosed herein, and without intending to publicly dedicate any patentable subject matter.

## CLAIMS

What is claimed is:

1. A method of inserting a modular intra-ocular lens (IOL) into an eye, the modular IOL including a base and a lens, the method comprising:
  - a. loading the base and the lens into a barrel of an injector, the barrel having at least one internal lumen with at least one plunger disposed therein;
  - b. placing a distal end of the barrel into the eye;
  - c. advancing the at least one plunger in the barrel to place the base and the lens into the eye;
  - d. assembling the base and lens in the eye.
2. A method as in claim 1, wherein loading the base and the lens into the barrel includes placing the base and lens into the barrel such that the base is distal of the lens.
3. A method as in claim 1, wherein advancing the at least one plunger in the barrel pushes the base distally out of the distal end of the barrel and into the eye.
4. A method as in claim 3, wherein advancing the at least one plunger in the barrel includes continuing to advance the at least one plunger in the barrel to push the lens distally out of the distal end of the barrel and into the eye.
5. A method as in claim 1, wherein loading the base and the lens into the barrel includes placing the base and lens into the barrel using in-line cartridges.

6. A method as in claim 1, wherein the at least one internal lumen includes first and second side-by-side internal lumens merging into a common distal lumen disposed distally of the first and second lumens, and first and second plungers disposed in the first and second lumens.

7. A method as in claim 6, wherein loading the base and the lens into the barrel includes placing the base into the first lumen and placing the lens into the second lumen.

8. A method as in claim 7, wherein advancing the at least one plunger in the barrel includes advancing the first plunger in the first lumen to push the base distally out of the barrel and into the eye.

9. A method as in claim 8, wherein advancing the at least one plunger in the barrel includes retracting the first plunger.

10. A method as in claim 9, wherein advancing the at least one plunger in the barrel includes advancing the second plunger in the second lumen to push the lens distally out of the barrel and into the eye.

11. A method as in claim 1, wherein the base and the lens are placed into the eye sequentially.

12. A method as in claim 1, wherein the base and the lens are placed into the eye simultaneously.

13. A method of inserting a modular intra-ocular lens (IOL) into an eye, the modular IOL including a base and a lens, the method comprising:
- a. placing the base and lens into a barrel of an injector, the barrel having a single internal lumen with a pair of coaxial inner and outer plungers disposed therein, such that the base is distal of the lens;
  - b. placing a distal end of the barrel into the eye;
  - c. advancing the inner plunger in the barrel to push the base distally out of the distal end of the barrel and into the eye;
  - d. retracting the inner plunger;
  - e. advancing the outer plunger over the inner plunger to push the lens distally out of the distal end of the barrel and into the eye; and
  - f. assembling the base and lens in the eye.
14. A method as in claim 13, wherein placing the base and lens into the barrel includes side-loading the base and lens into the barrel.
15. A method as in claim 14, wherein side-loading the base and lens includes inserting a first side-loading cartridge containing the base into the barrel and inserting a second side-loading cartridge containing the lens into the barrel.
16. A method of inserting a modular intra-ocular lens (IOL) into an eye, the modular IOL including a base and a lens, the method comprising:
- a. side-loading the base into a barrel of an injector, the barrel having a single internal lumen with a plunger disposed therein;

- b. placing a distal end of the barrel into the eye;
- c. advancing the plunger in the barrel to push the base distally out of the distal end of the barrel and into the eye;
- d. retracting the inner plunger;
- e. side-loading the lens into the barrel;
- f. advancing the plunger in the barrel to push the lens distally out of the distal end of the barrel and into the eye; and
- g. assembling the base and lens in the eye.

17. A method as in claim 16, wherein the base and lens are placed in the barrel using first and second side-loading cartridges, respectively.

18. A method as in claim 17, wherein the base is placed in the barrel by pushing the first cartridge into the barrel, and wherein the lens is placed in the barrel by pushing the second cartridge into the barrel after the base has been advanced distally and the plunger has been retracted.

19. An intraocular lens system, comprising:
- a. an annular base having two radially-outward extending haptics, the base having a center hole, an inside perimeter, and a radially-inward open recess around the inside perimeter;
  - b. a lens having an optical body with first and second tabs extending radially outward from the optical body, wherein the base and lens are assembled with the first and second tabs disposed in the recess of the base, wherein the first tab comprises an

actuatable spring, the second tab comprises a non-actuatable extension, and radial compression of the first tab facilitates assembly of the lens with the base; and

c. wherein the intraocular lens system provides optical correction to an eye solely via the optical body of the lens.

20. An intraocular lens system as in claim 19, wherein the base has a body, the center hole extends in an anterior-posterior direction through the body to form a continuous annular ring having the inside perimeter, the radially-inward open recess extends continuously around an entirety of the inside perimeter, the radially-inward open recess is defined by an anterior-facing posterior wall, a radially-inward-facing lateral wall, and a posterior-facing anterior wall, and the base is configured to fit within a lens capsule.

21. An intraocular lens system as in claim 19, wherein the first tab comprises a pair of actuatable cantilever springs, each with one end fixed relative to the optical body and one end free.

22. An intraocular lens system as in claim 21, wherein, when the base and lens are assembled, the free ends of the cantilever springs extend away from each other.

23. An intraocular lens system as in claim 21, wherein the free ends of the cantilever springs extend in opposing directions.

24. An intraocular lens system as in claim 21, wherein the free ends of the cantilever springs contact a radially-inward-facing lateral wall surrounding the radially-inward open recess.

25. An intraocular lens system as in claim 24, wherein the second tab contacts the radially-inward-facing lateral wall.

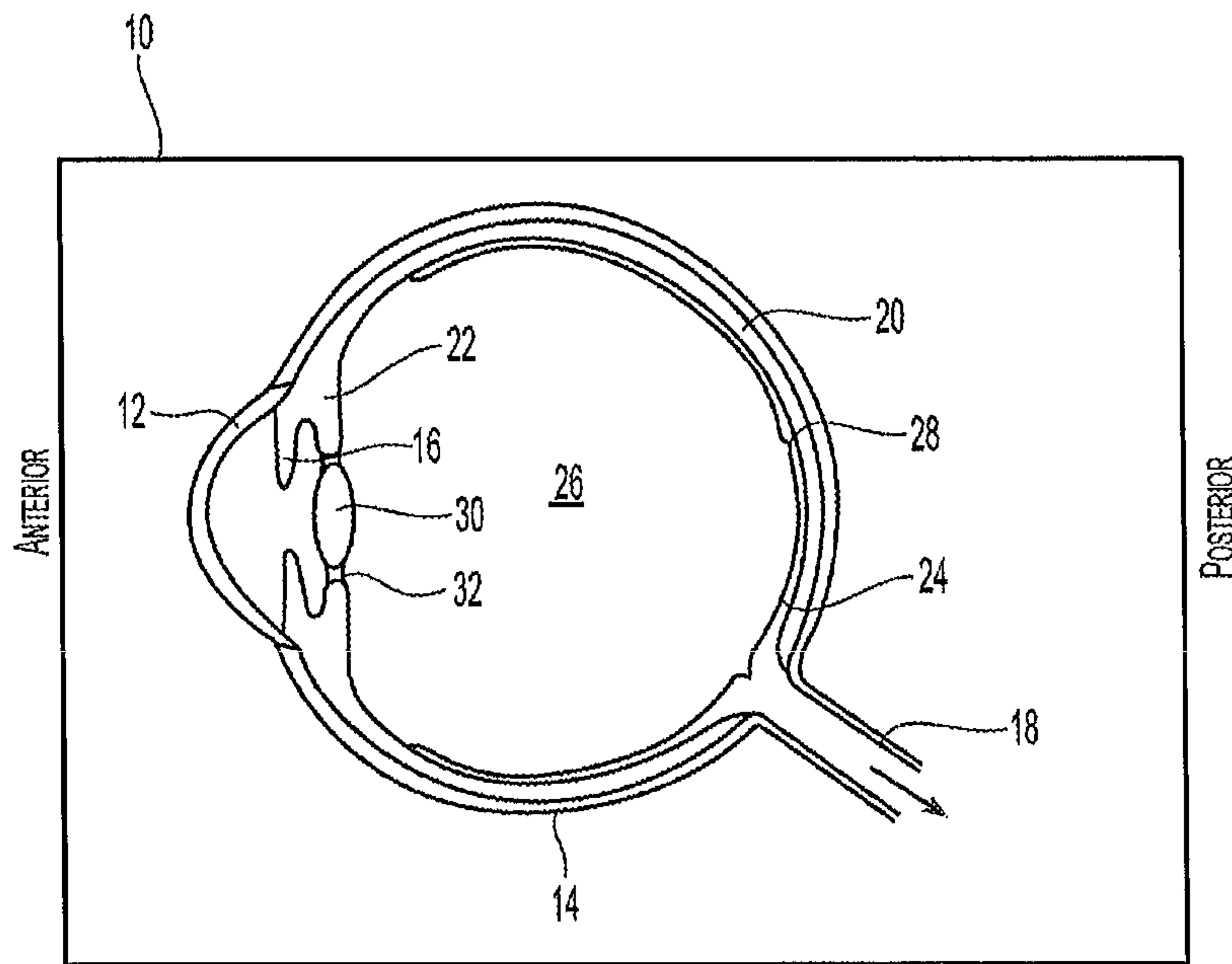
26. An intraocular lens system as in claim 25, wherein the free ends of the cantilever springs contact a first portion of the radially-inward-facing lateral wall, and the second tab contacts a second portion of the radially-inward-facing lateral wall, the first portion of the radially-inward-facing lateral wall being diametrically opposed to the second portion of the radially-inward-facing lateral wall.

27. An intraocular lens system as in claim 21, wherein the cantilever springs and the non-actuatable extension contact three spaced-apart locations on a radially-inward-facing lateral wall surrounding the radially-inward open recess.

28. An intraocular lens system as in claim 27, further comprising one or more drug carriers connected to the base.

29. An intraocular lens system as in claim 27, further comprising one or more sensors connected to the base.

30. An intraocular lens system as in claim 19, wherein radial compression of the first tab is required for assembly of the lens with the base.



**Fig. 1**

2/21

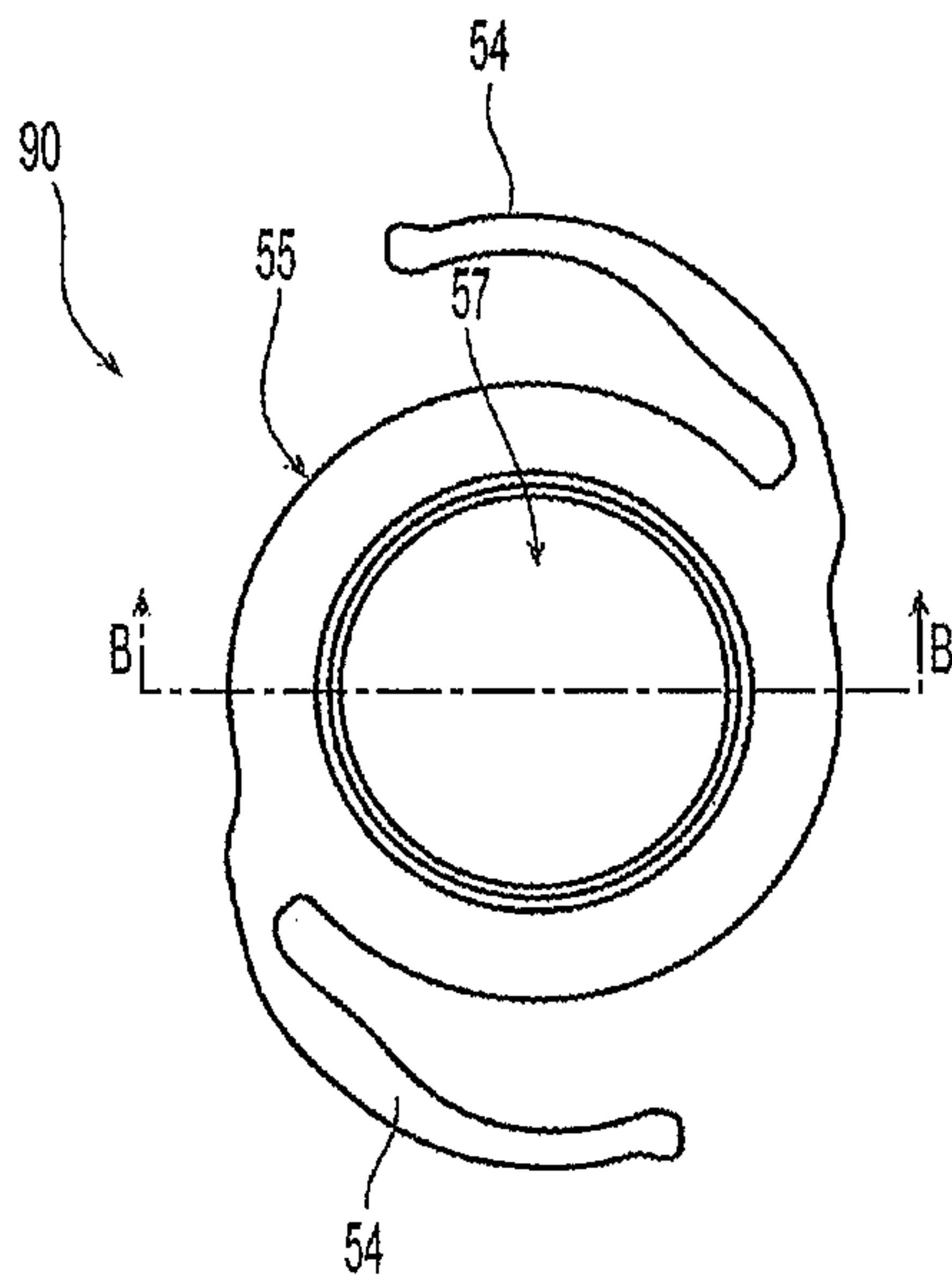


Fig. 2A

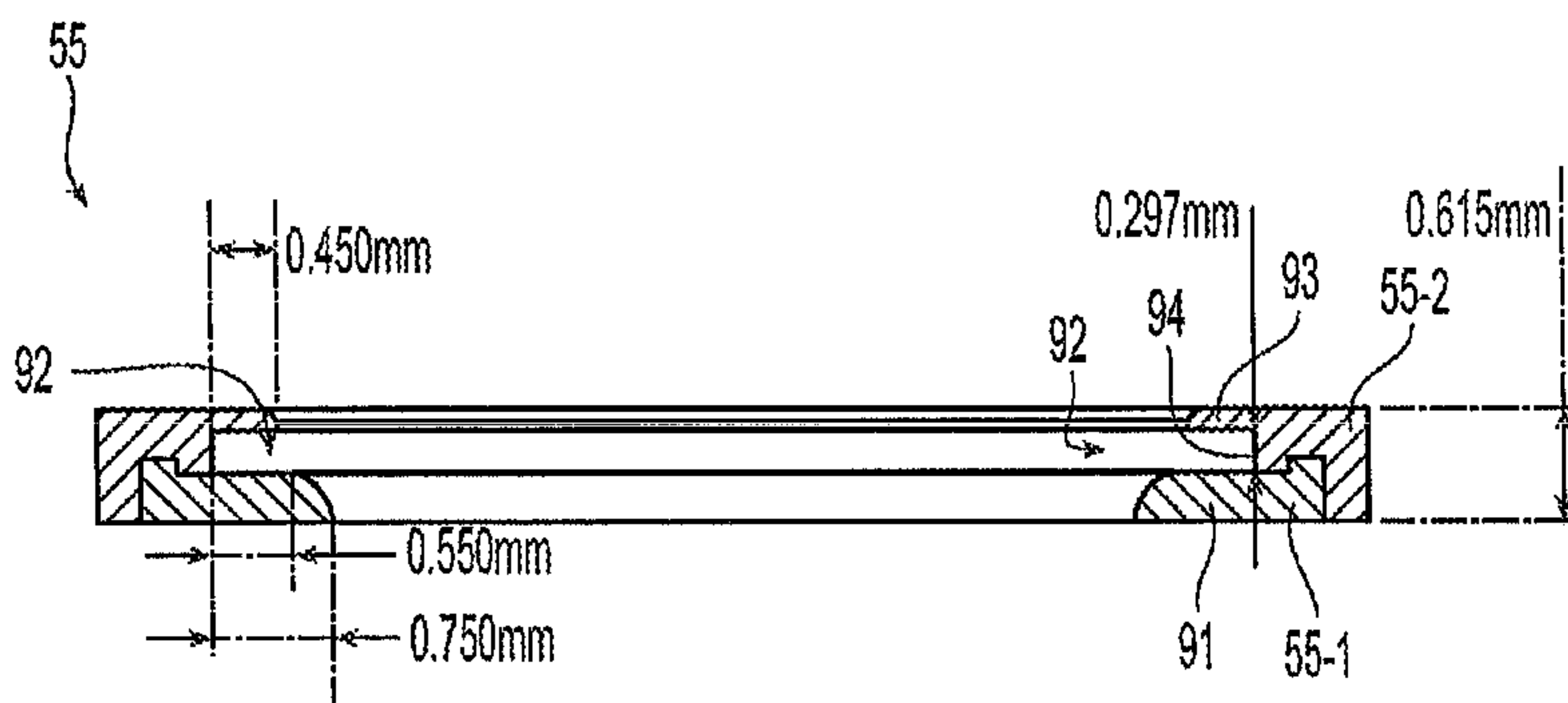


Fig. 2B

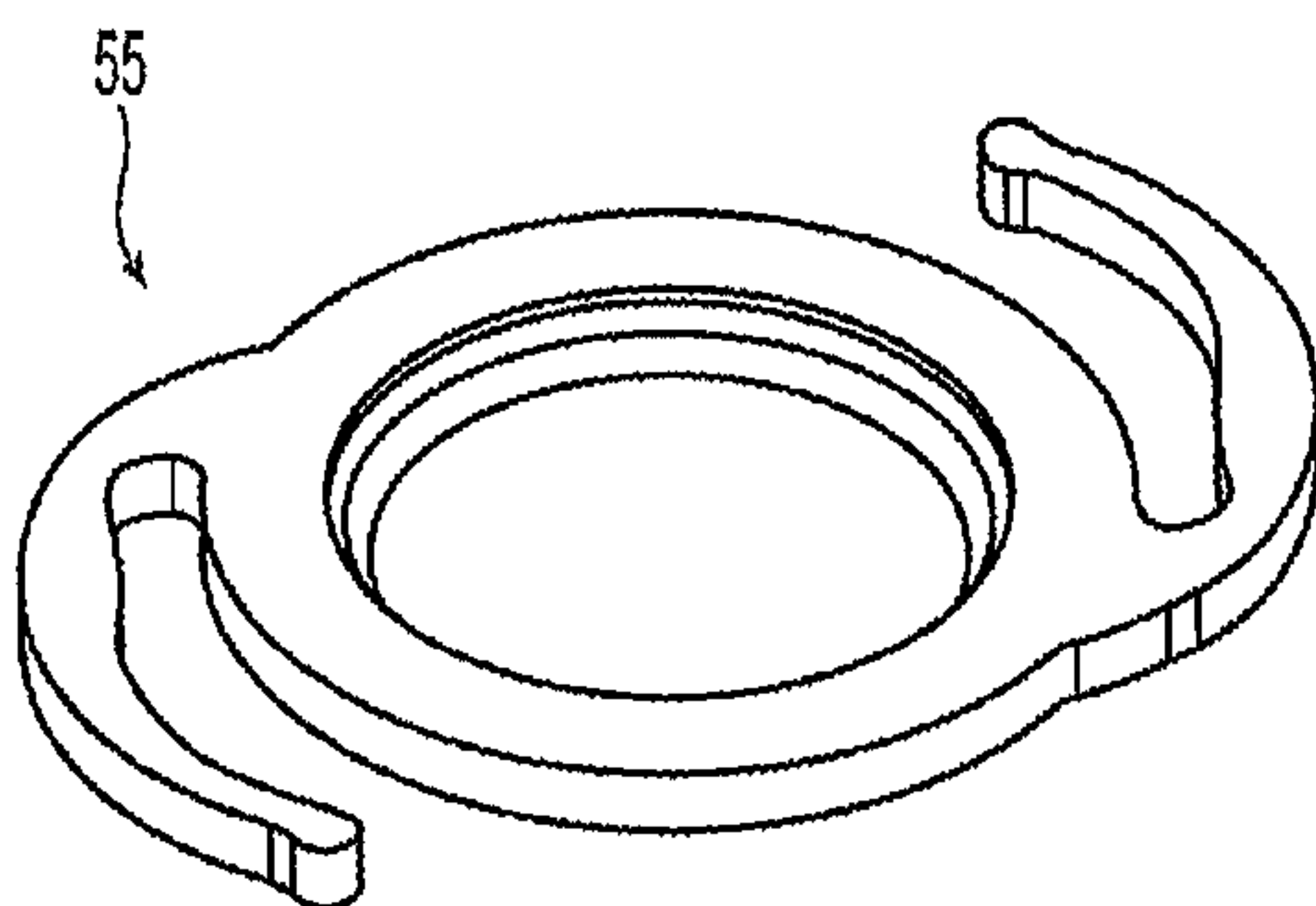


Fig. 2C



4/21

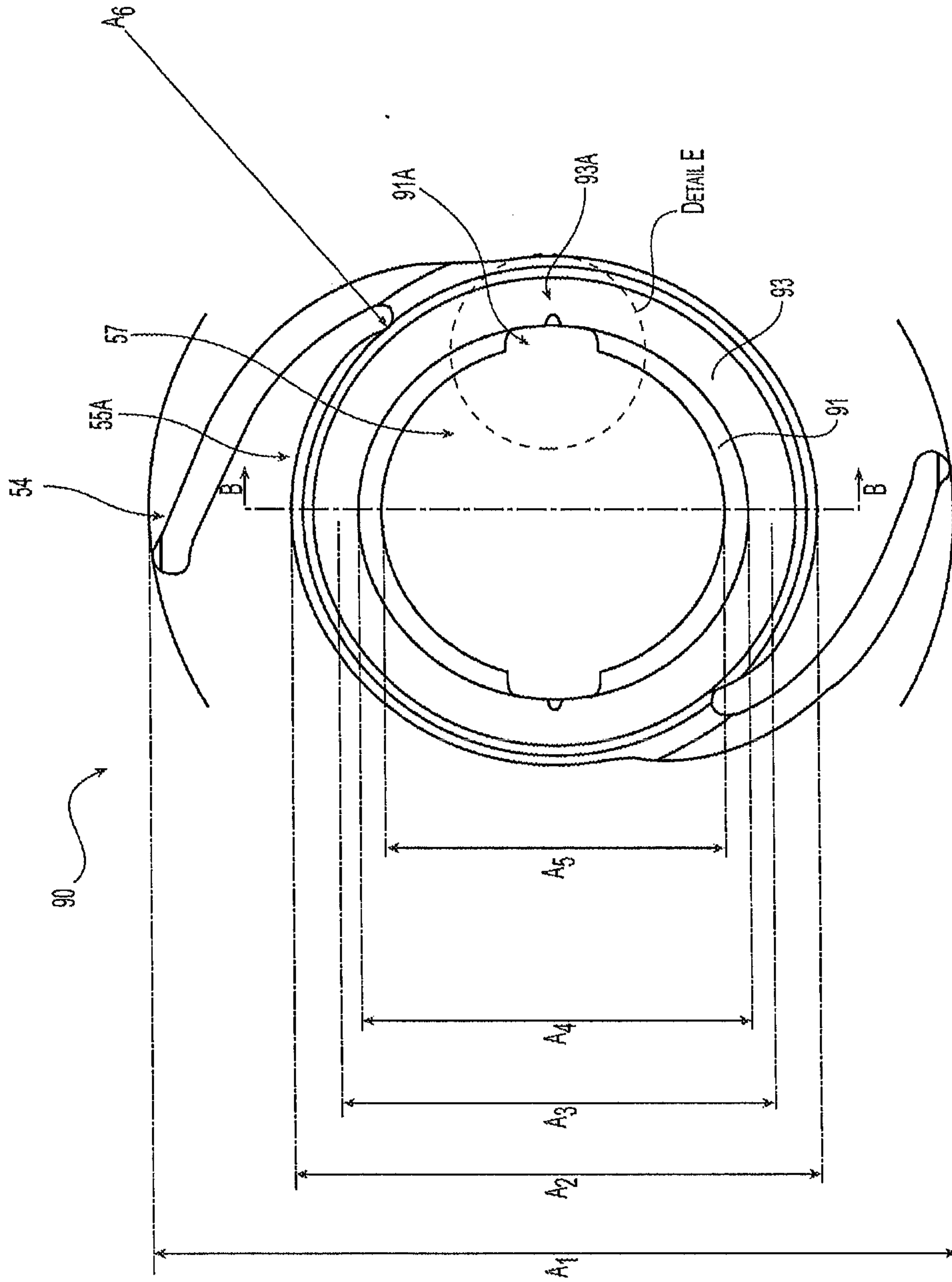


Fig. 3A



6/21

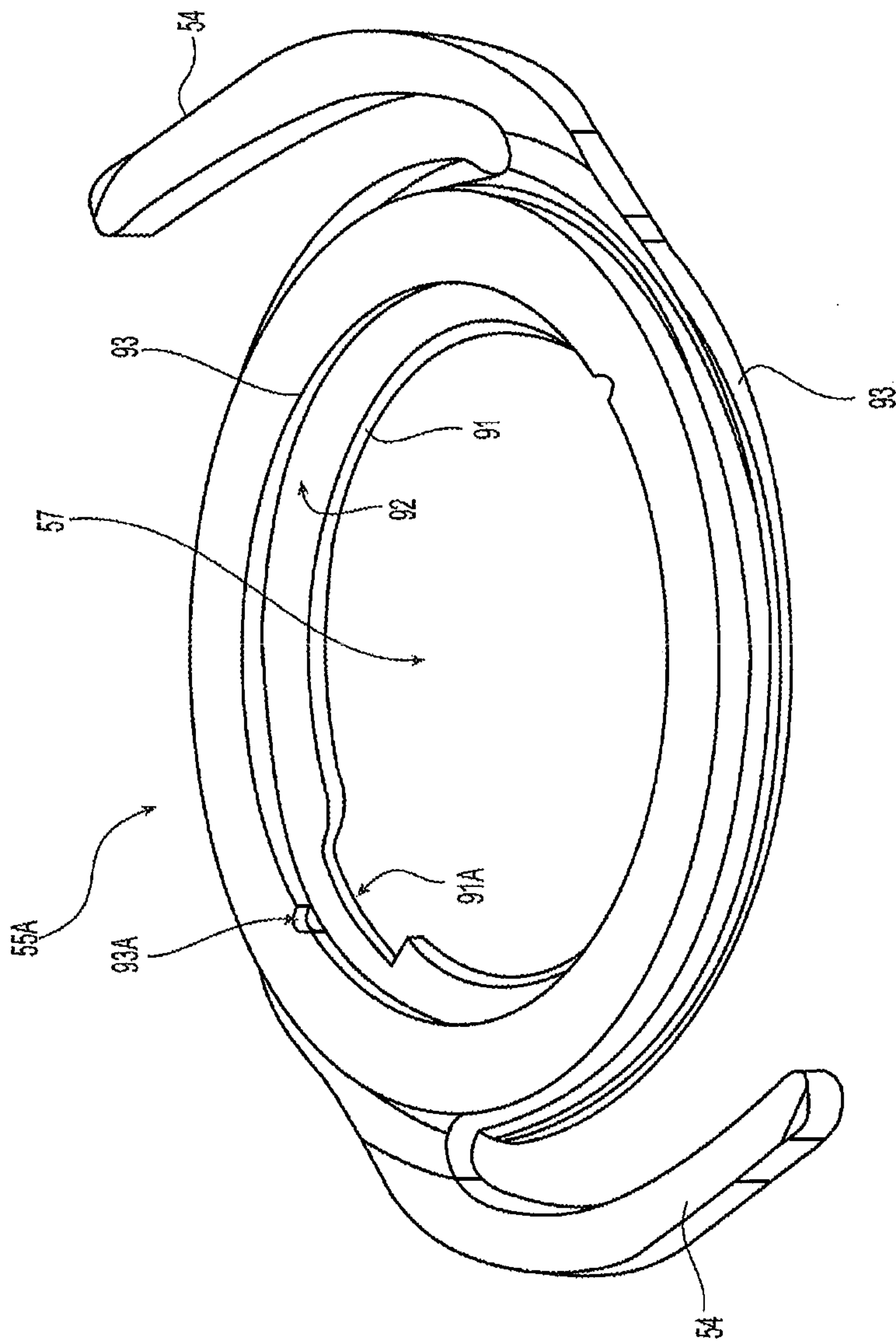


Fig. 3C

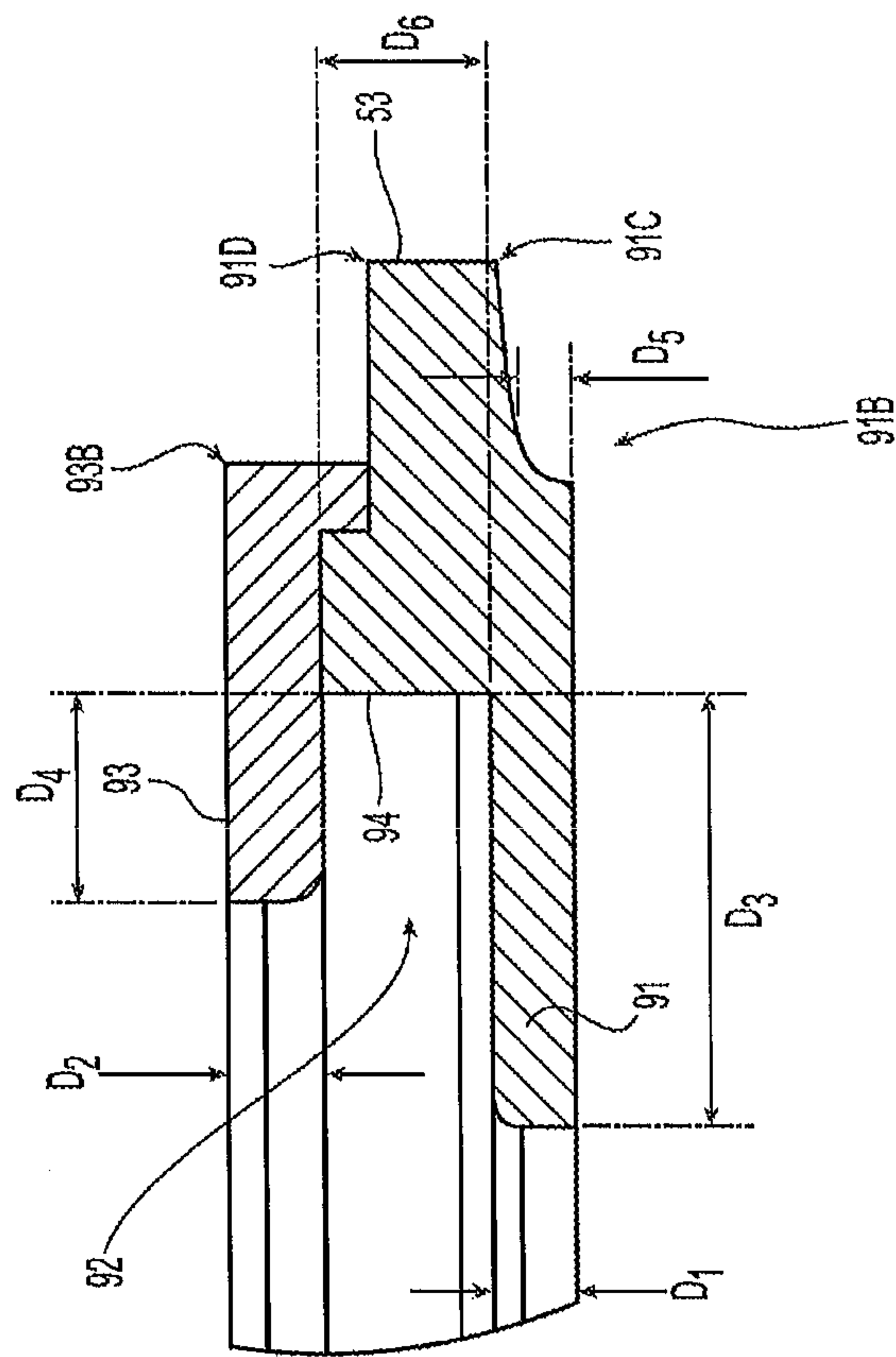


Fig. 3D

8/21

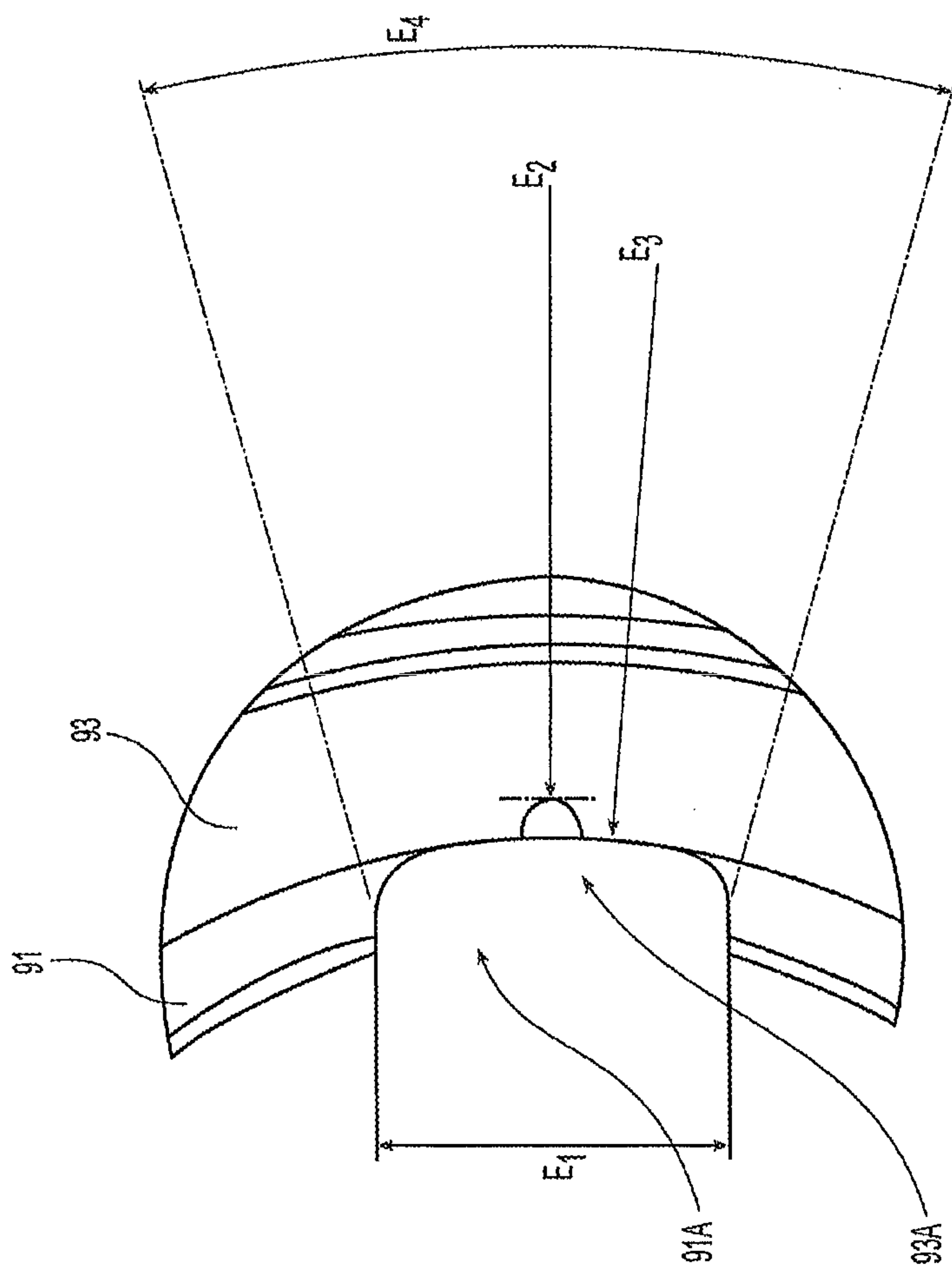


Fig. 3E

9/21

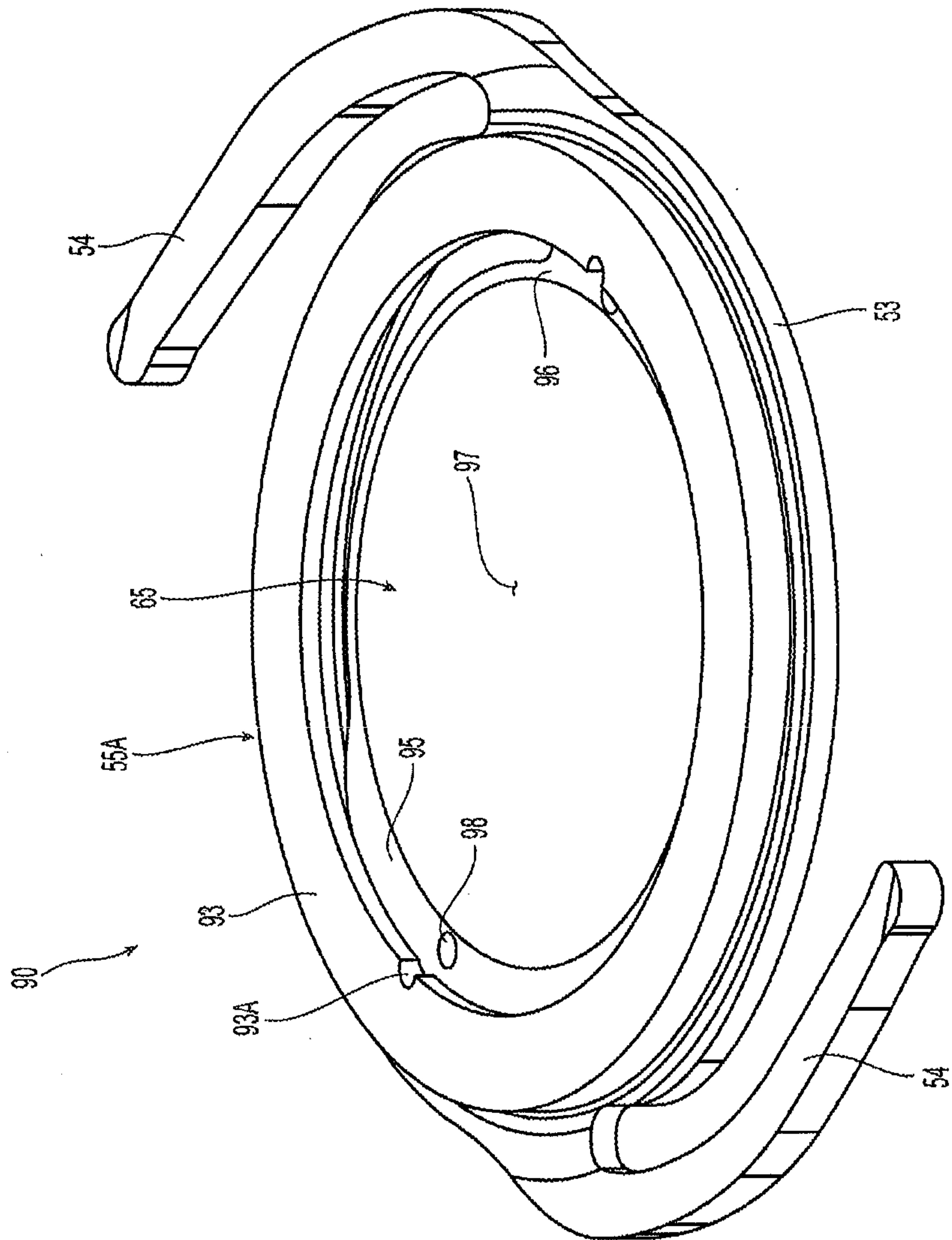


Fig. 3F

10/21

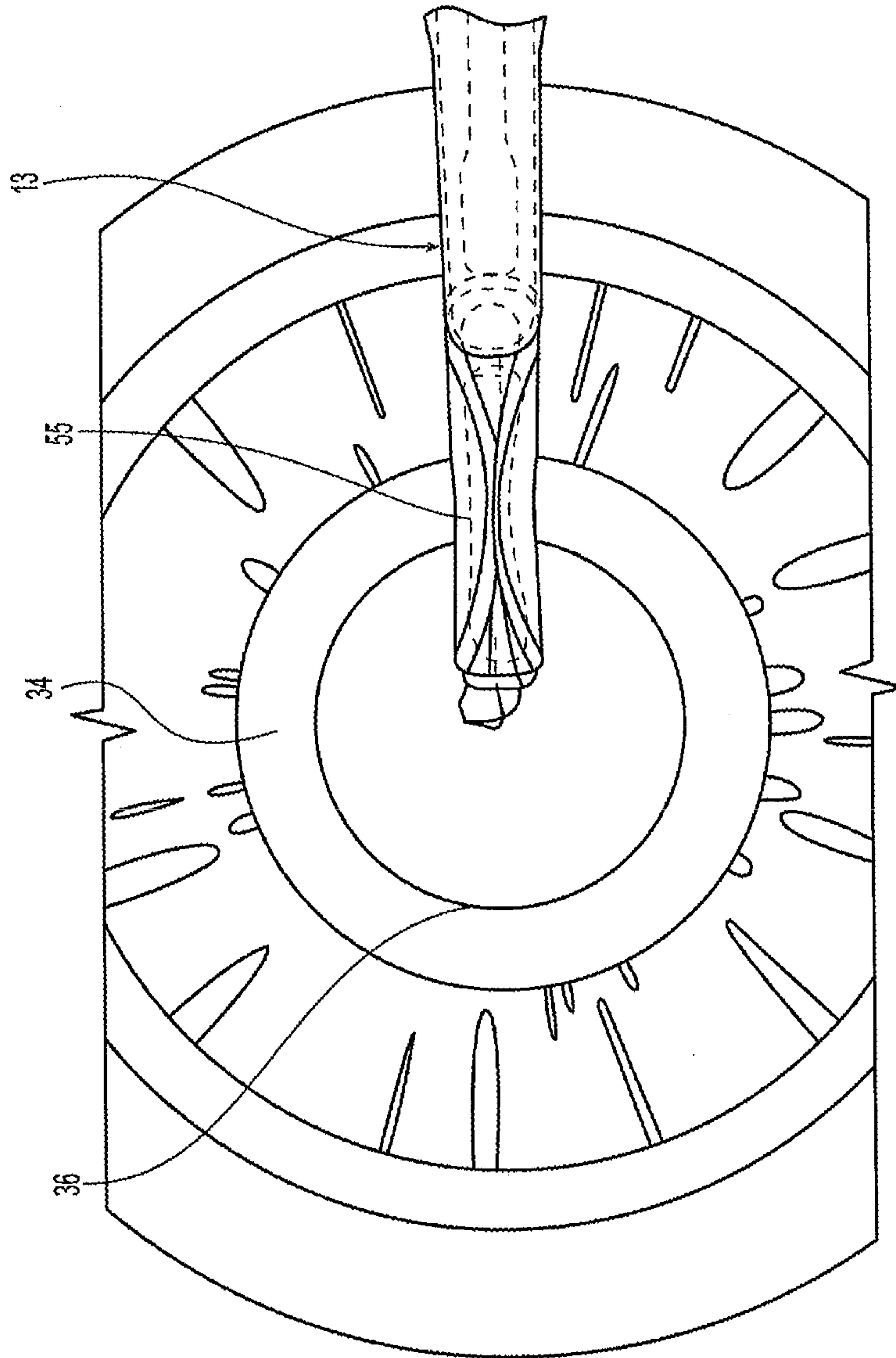


Fig. 4A

11/21

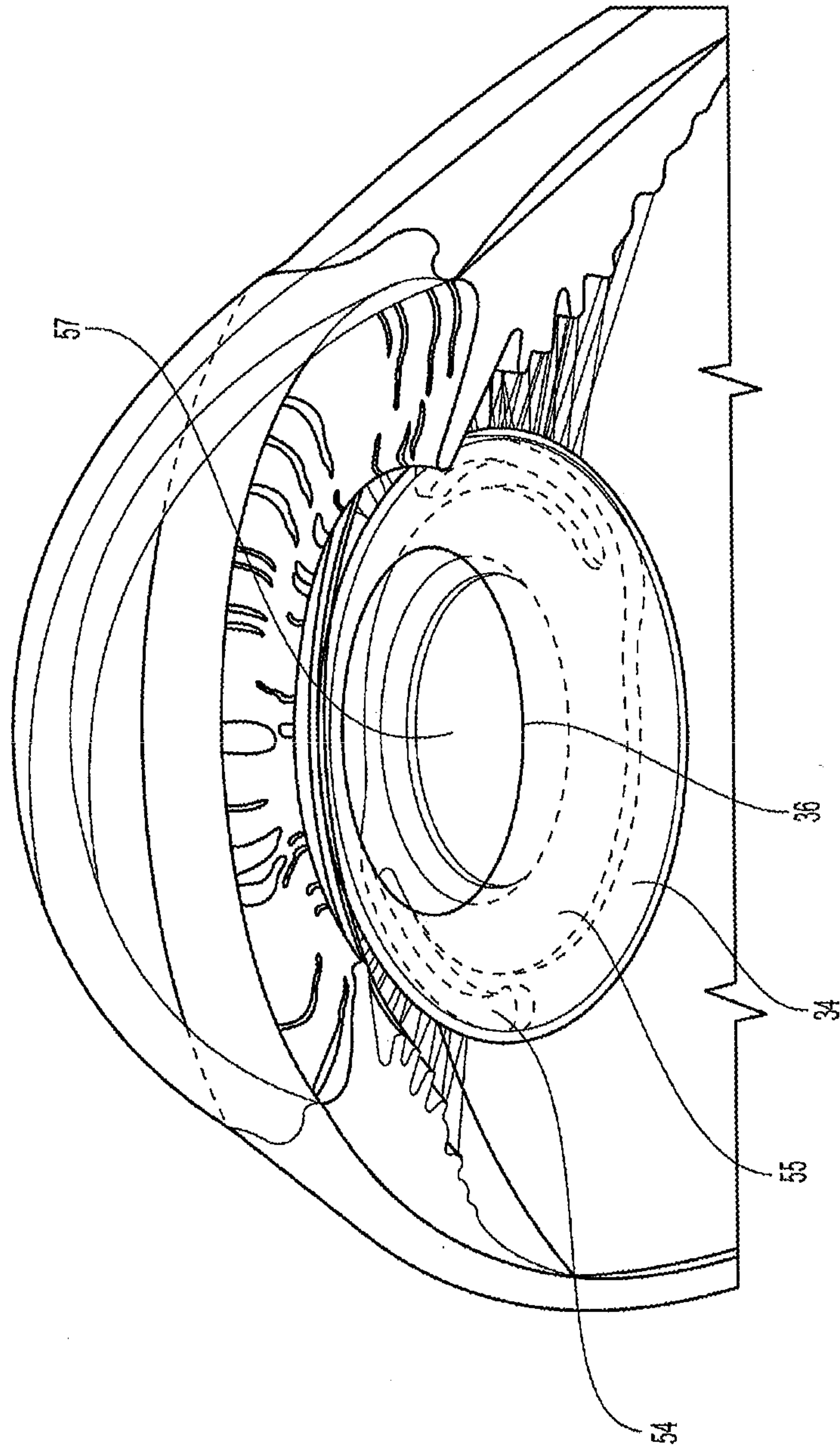


Fig. 4B

12/21

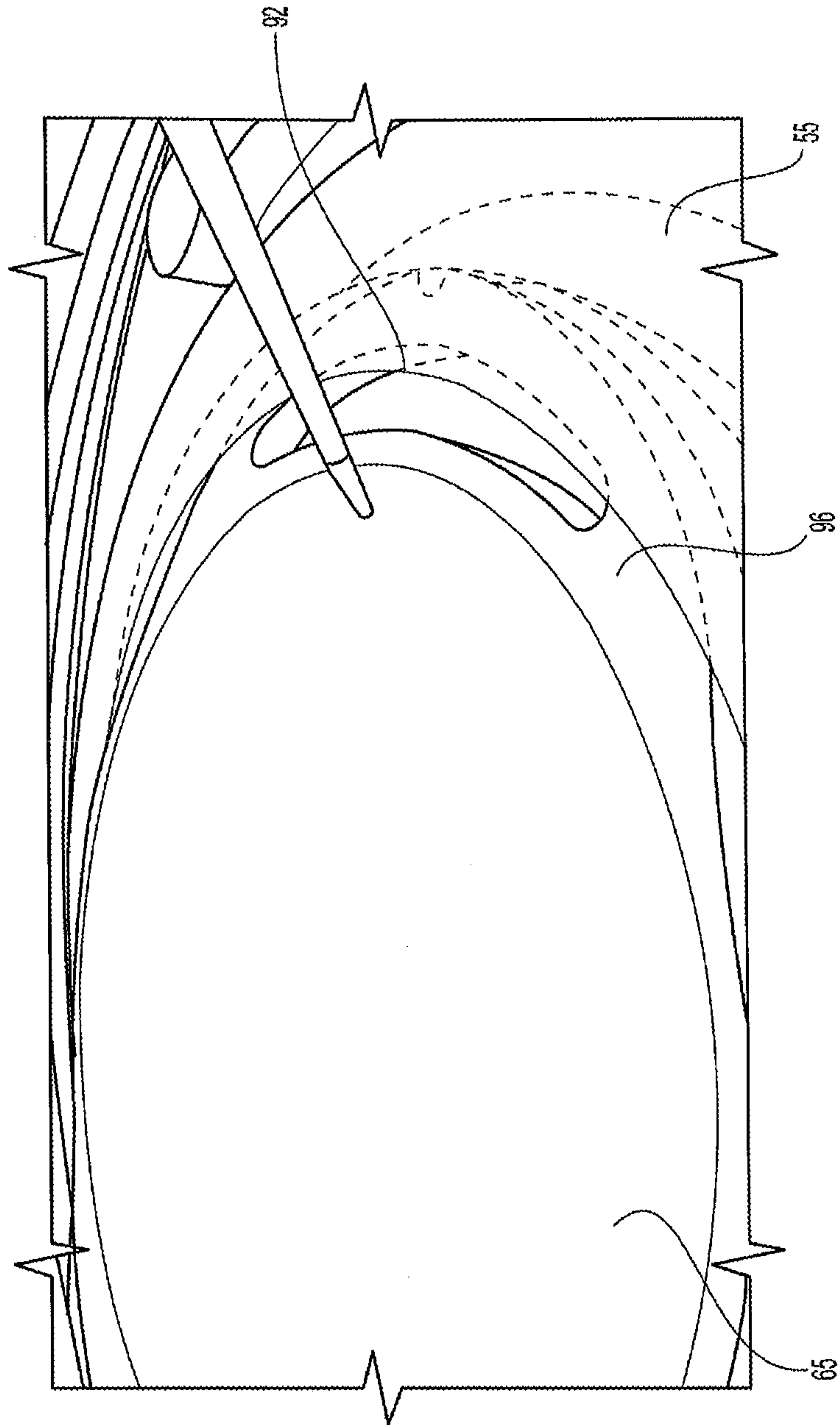


Fig. 4C

13/21

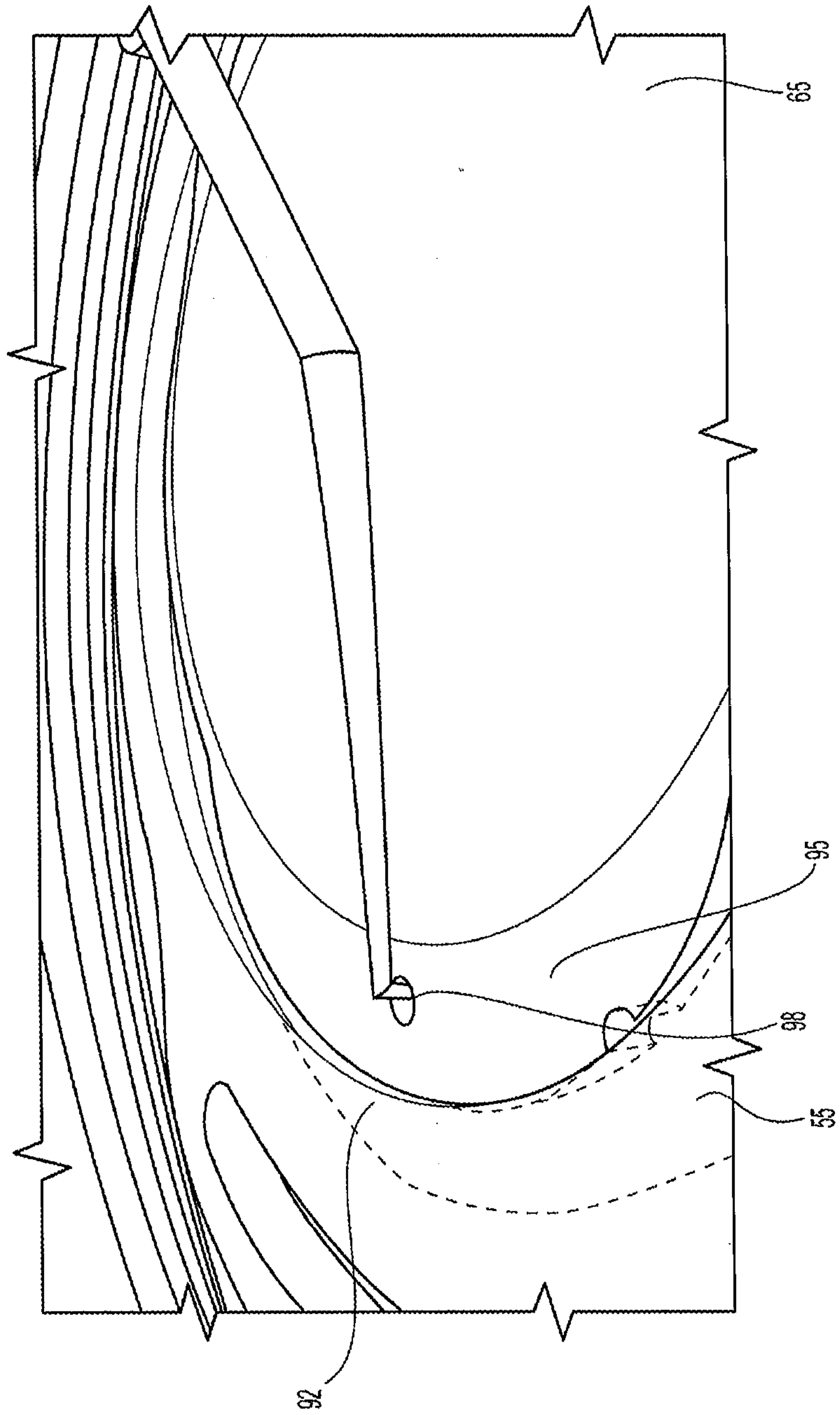


Fig. 4D

14/21

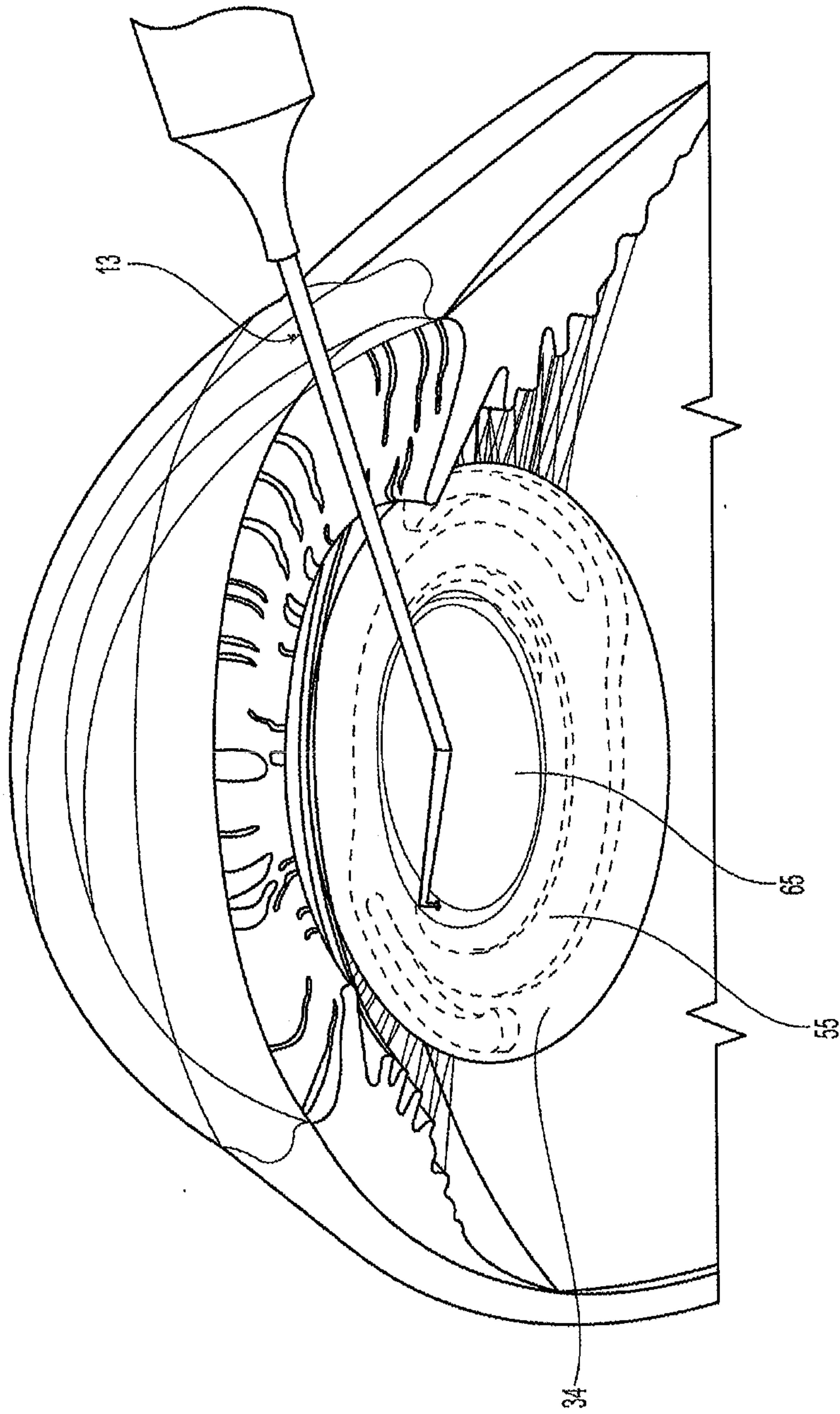


Fig. 4E

15/21

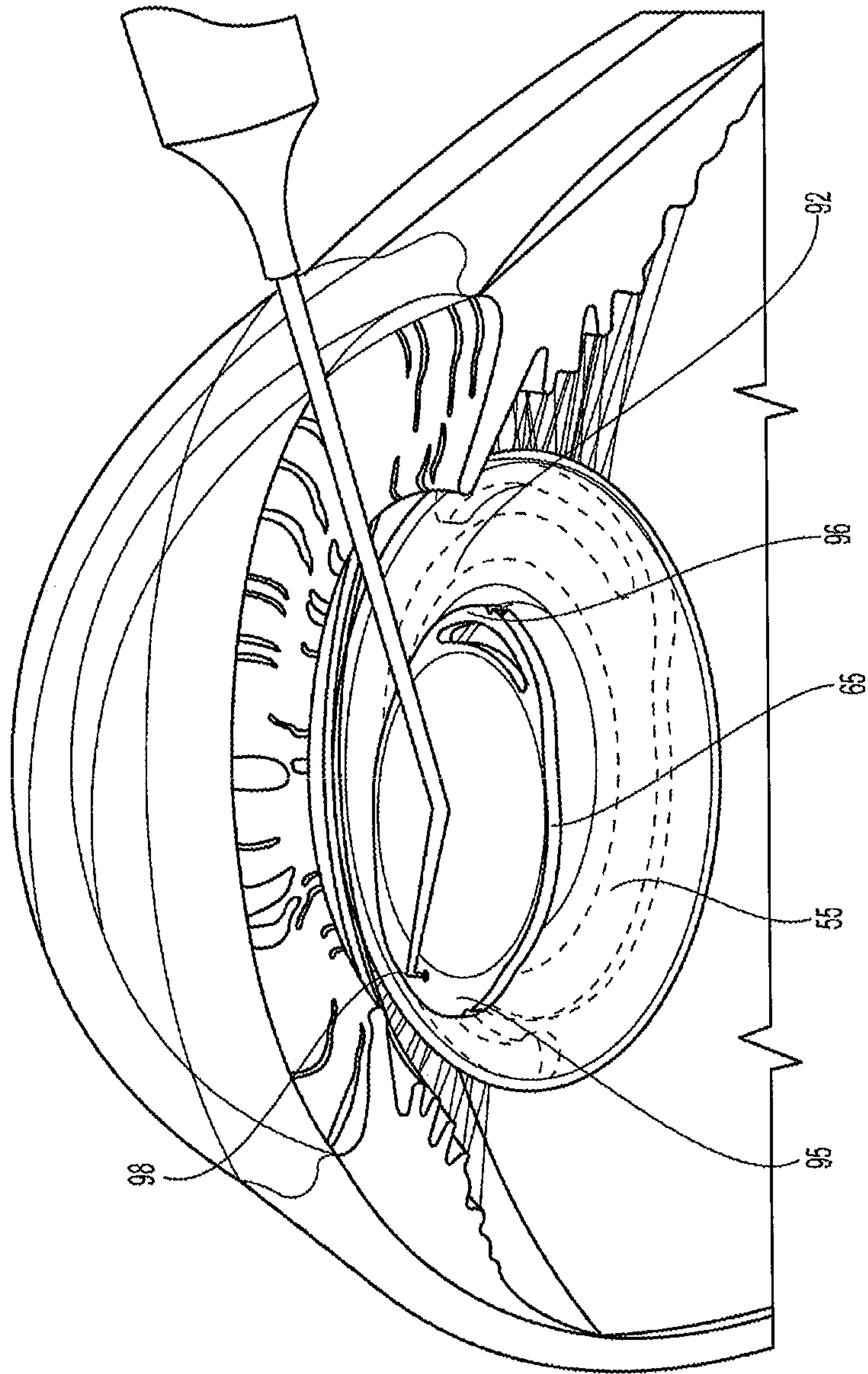


Fig. 4F

16/21

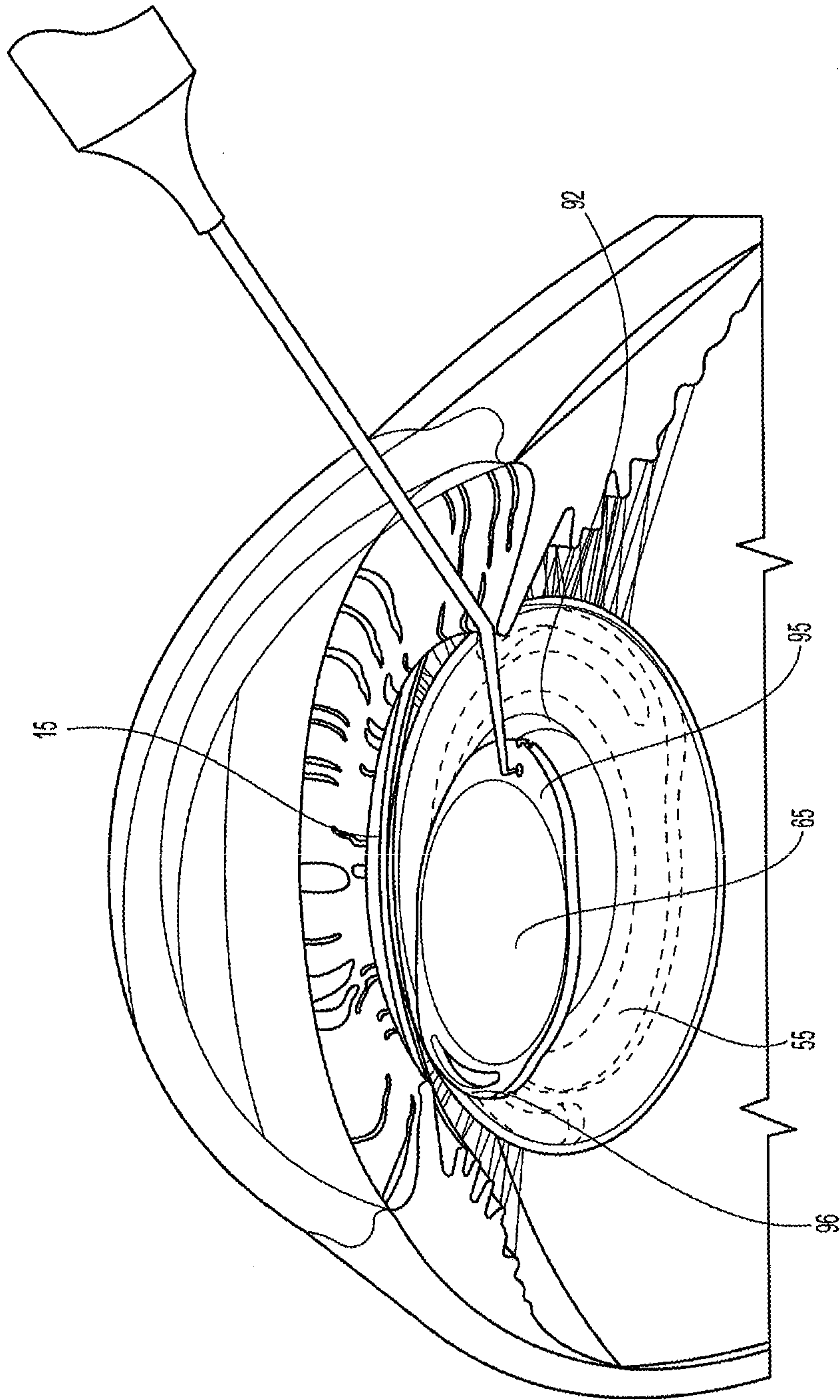
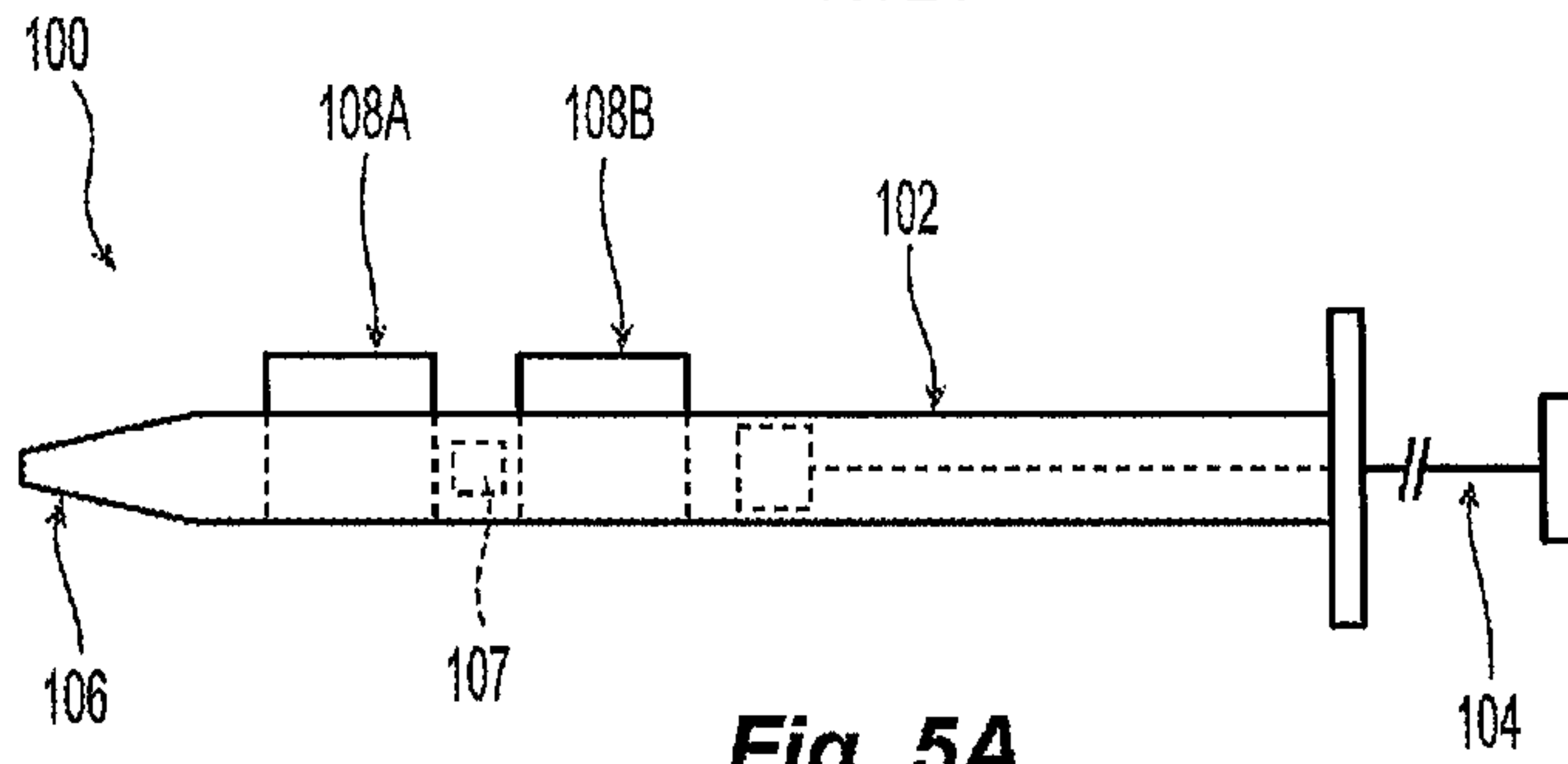
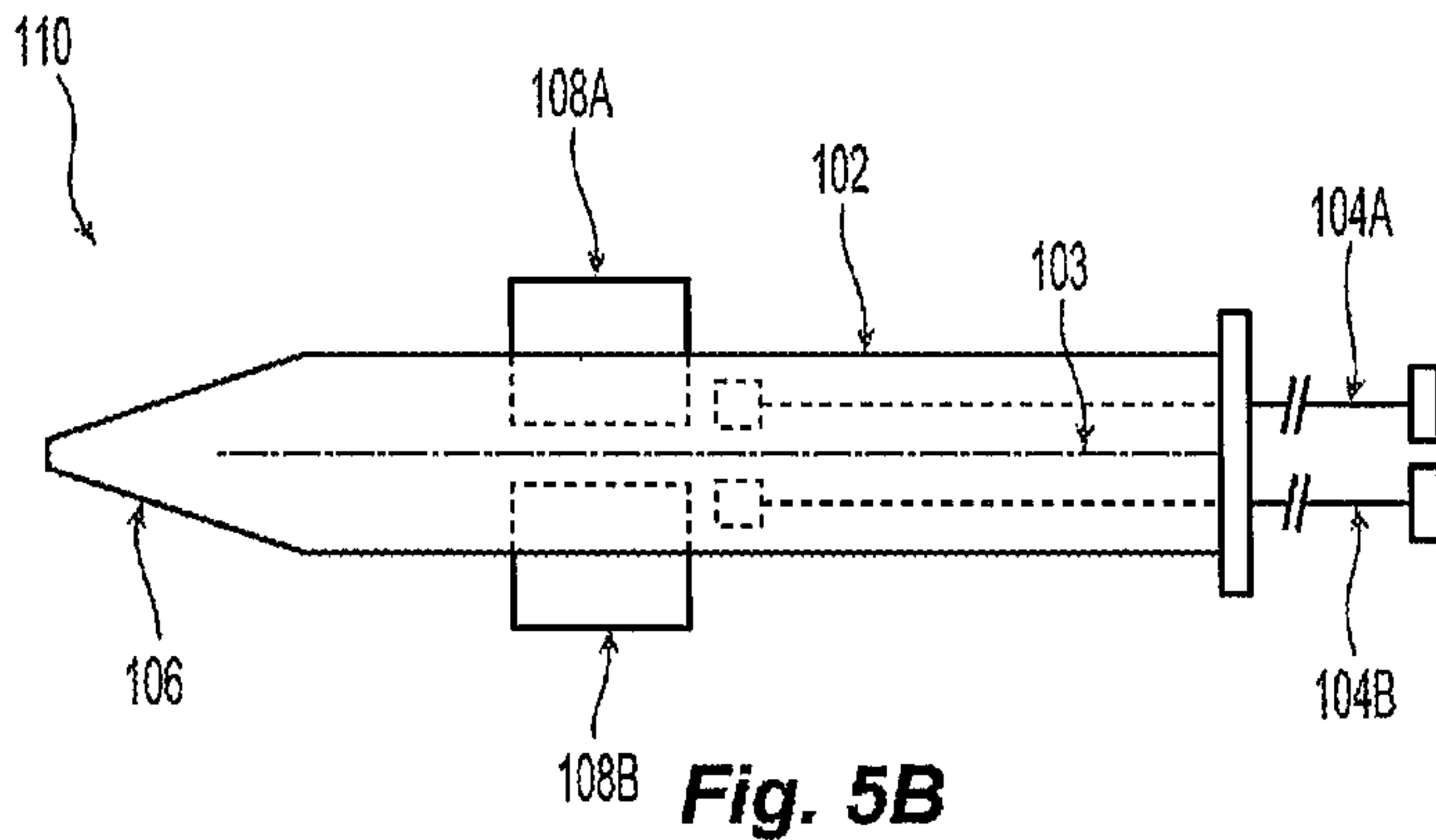


Fig. 4G

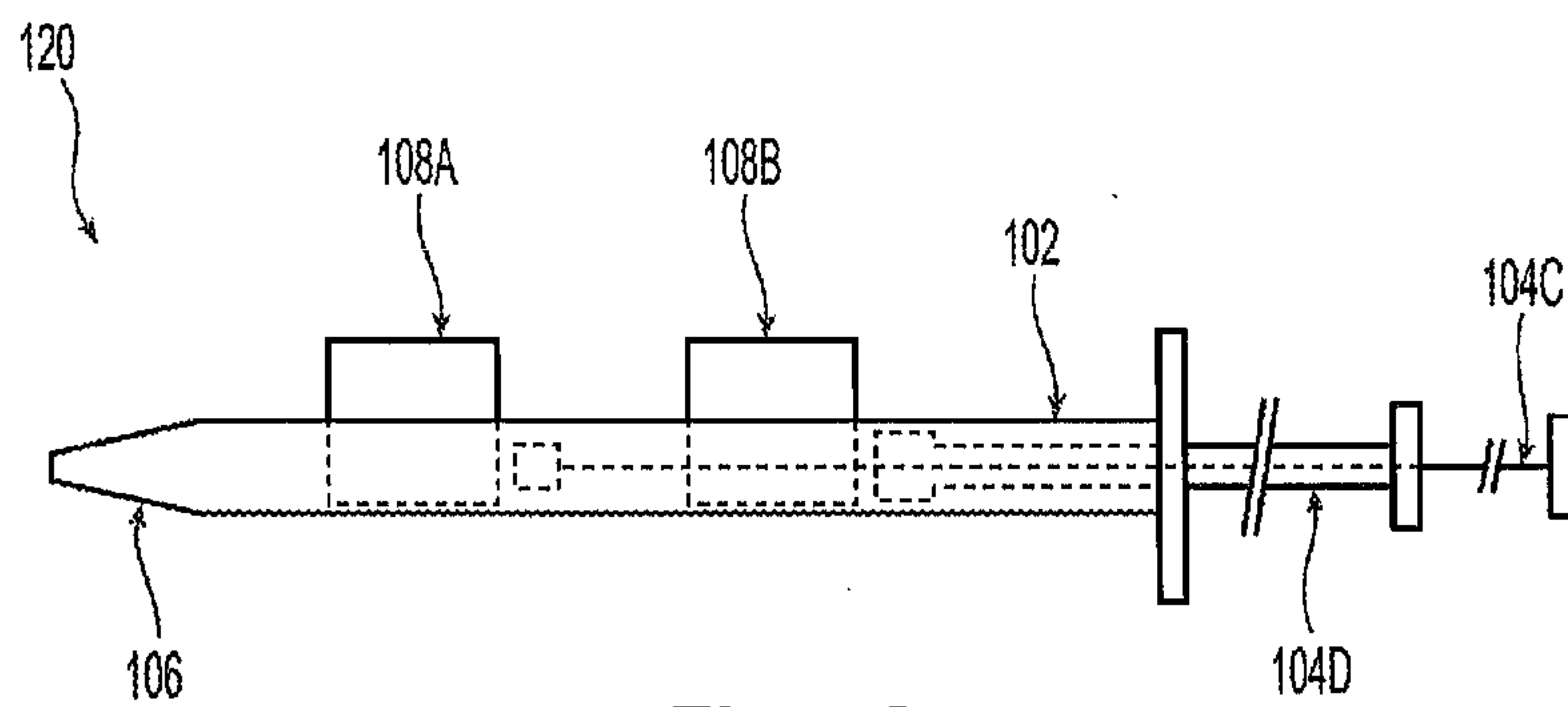
17/21



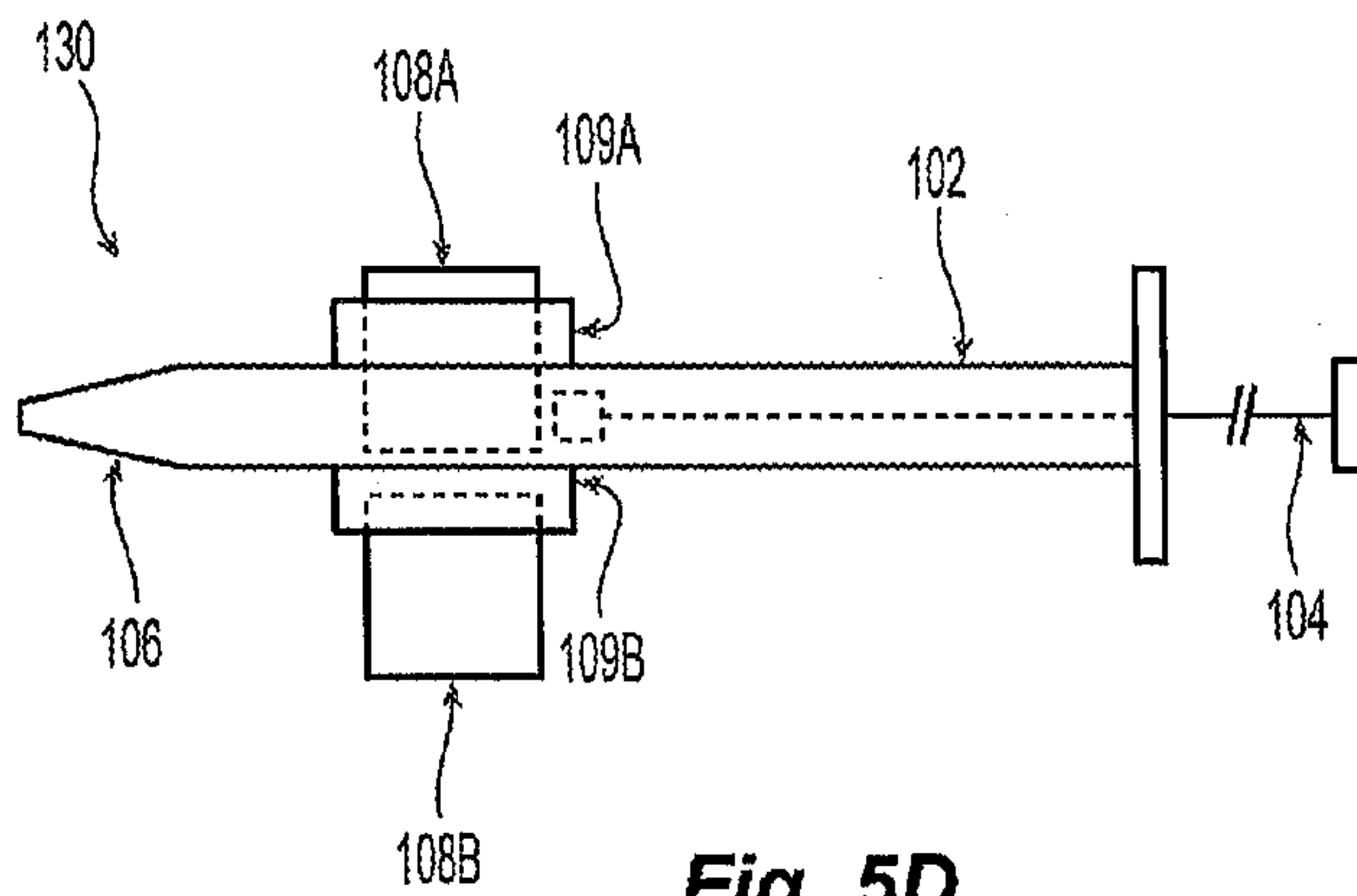
**Fig. 5A**



**Fig. 5B**

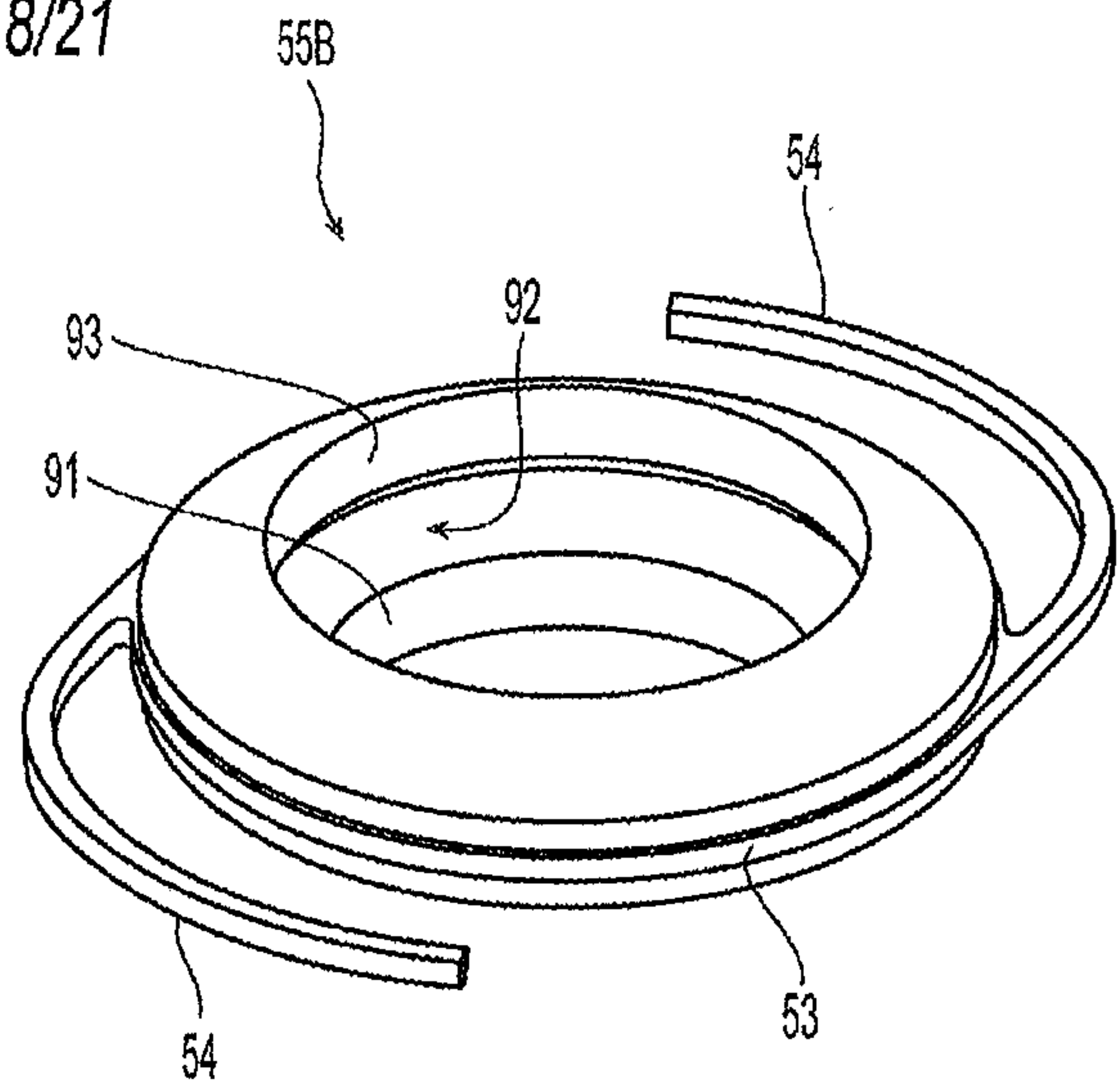


**Fig. 5C**

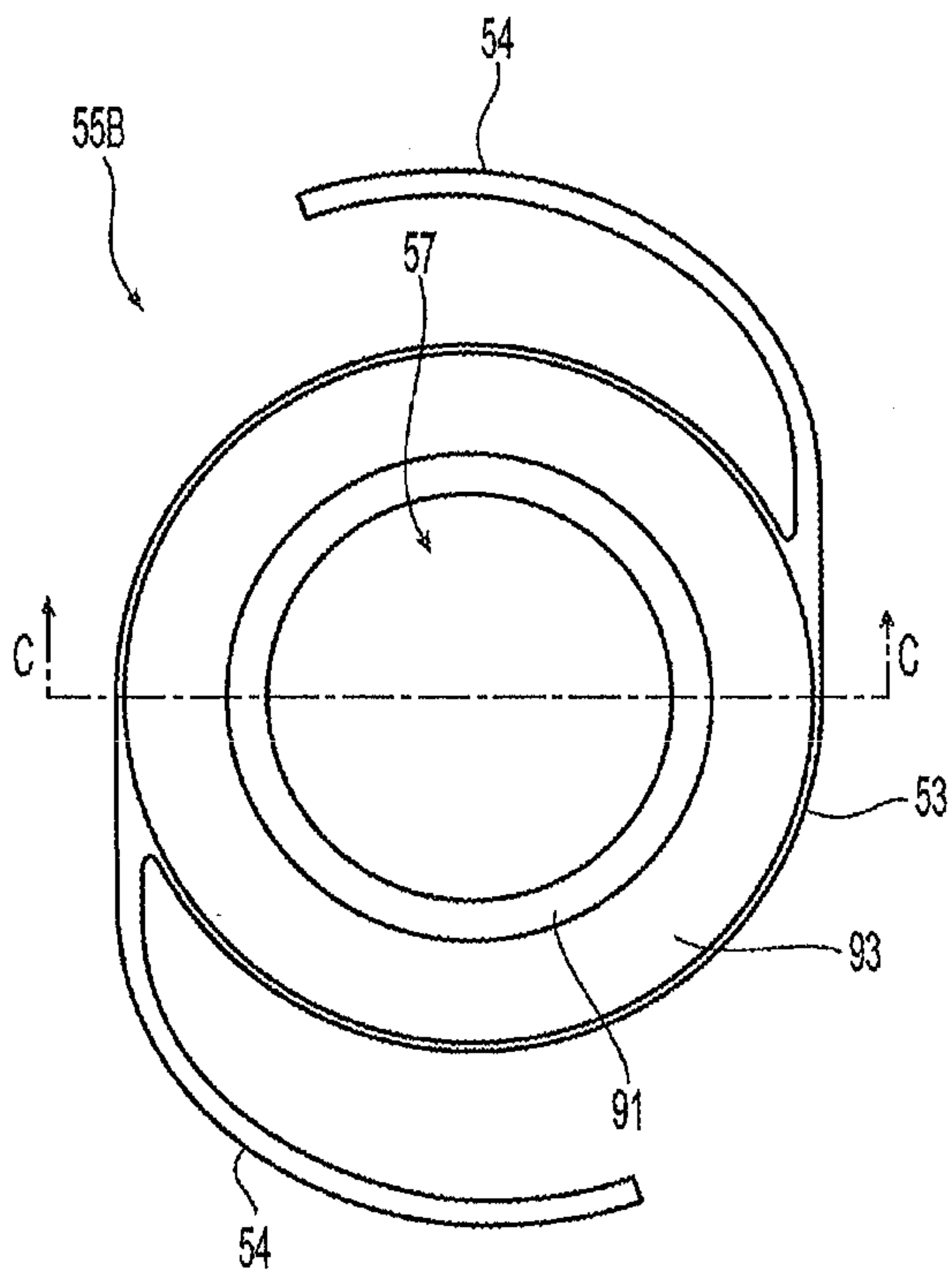


**Fig. 5D**

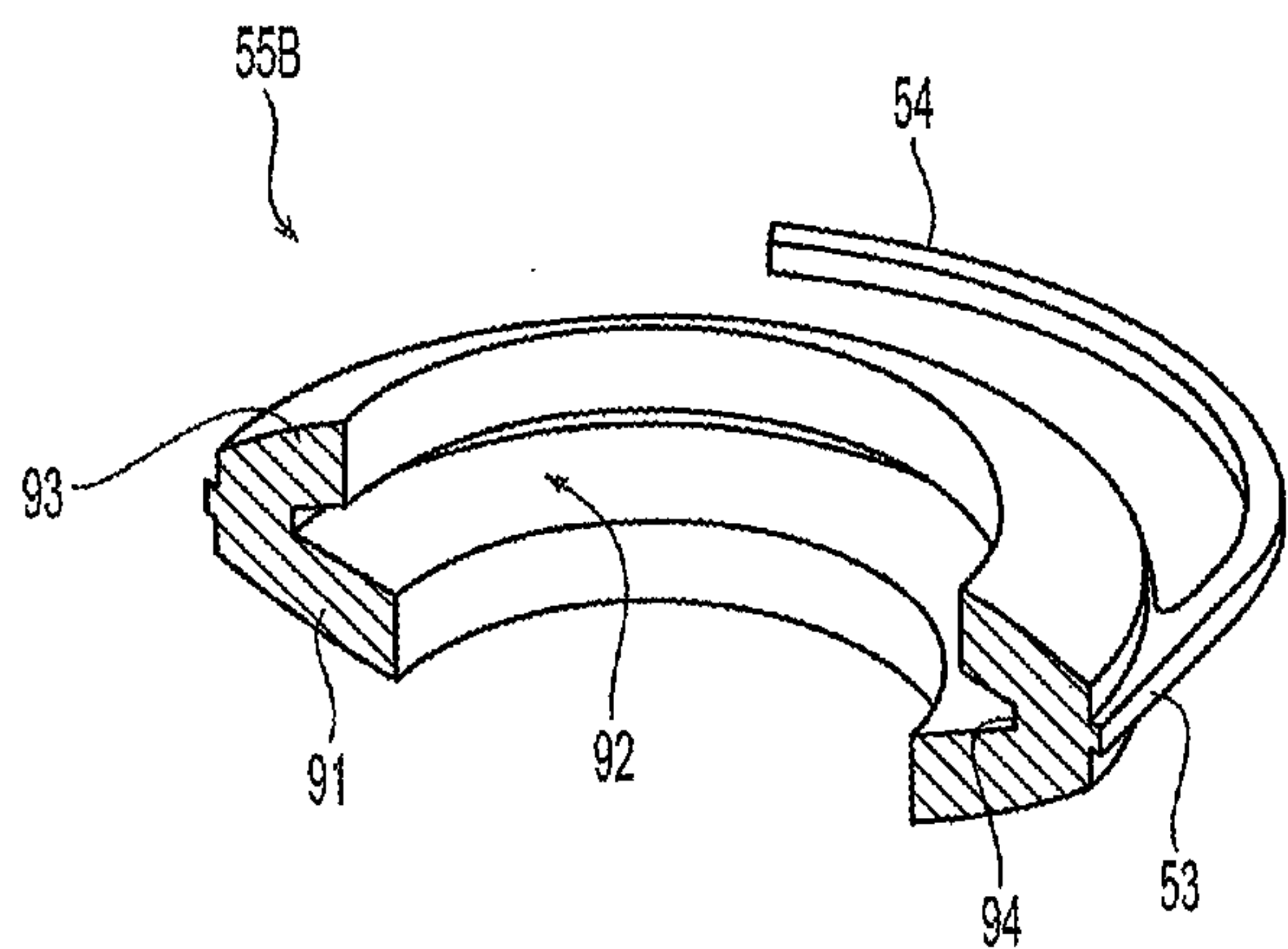
18/21



**Fig. 6A**

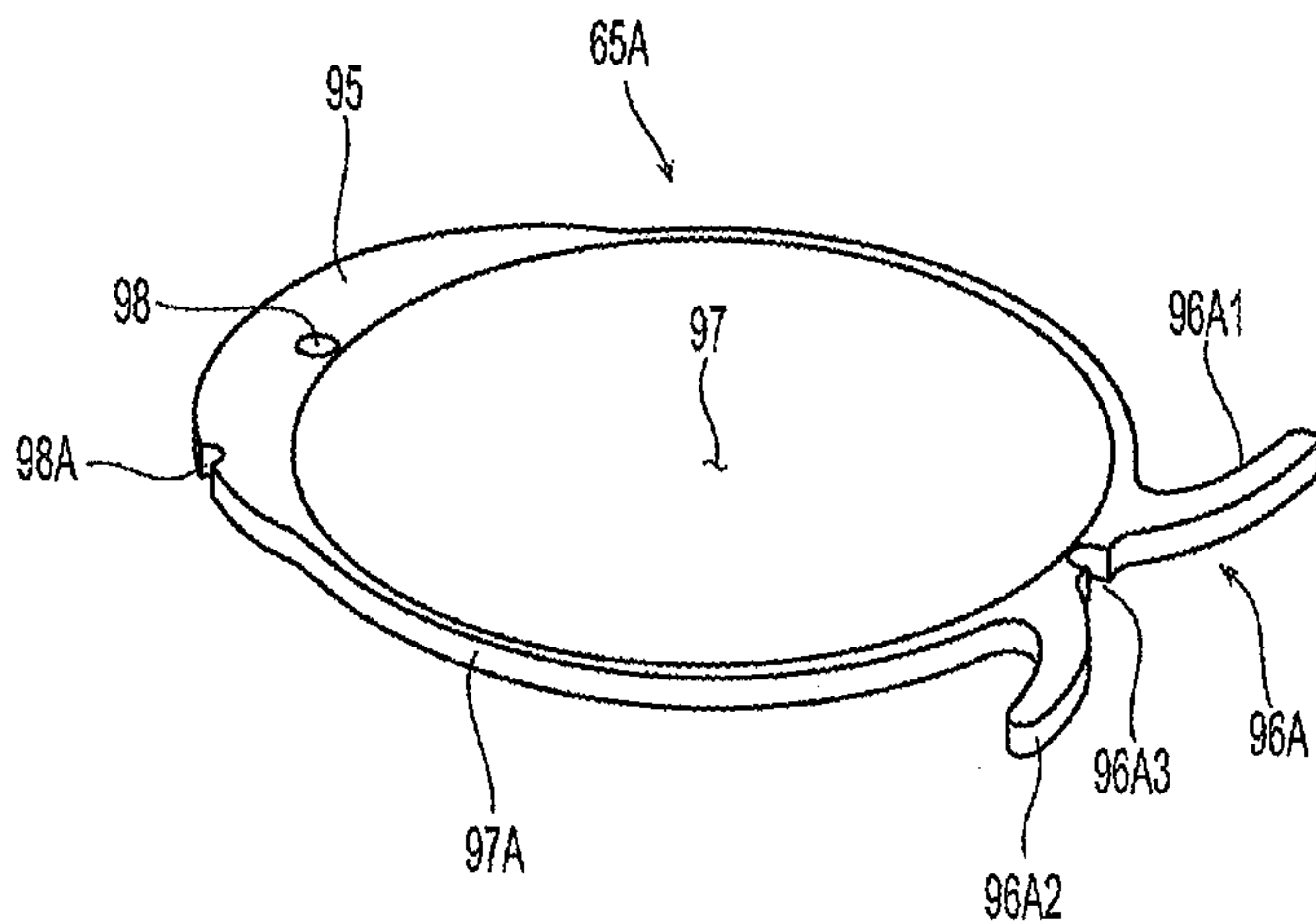


**Fig. 6B**

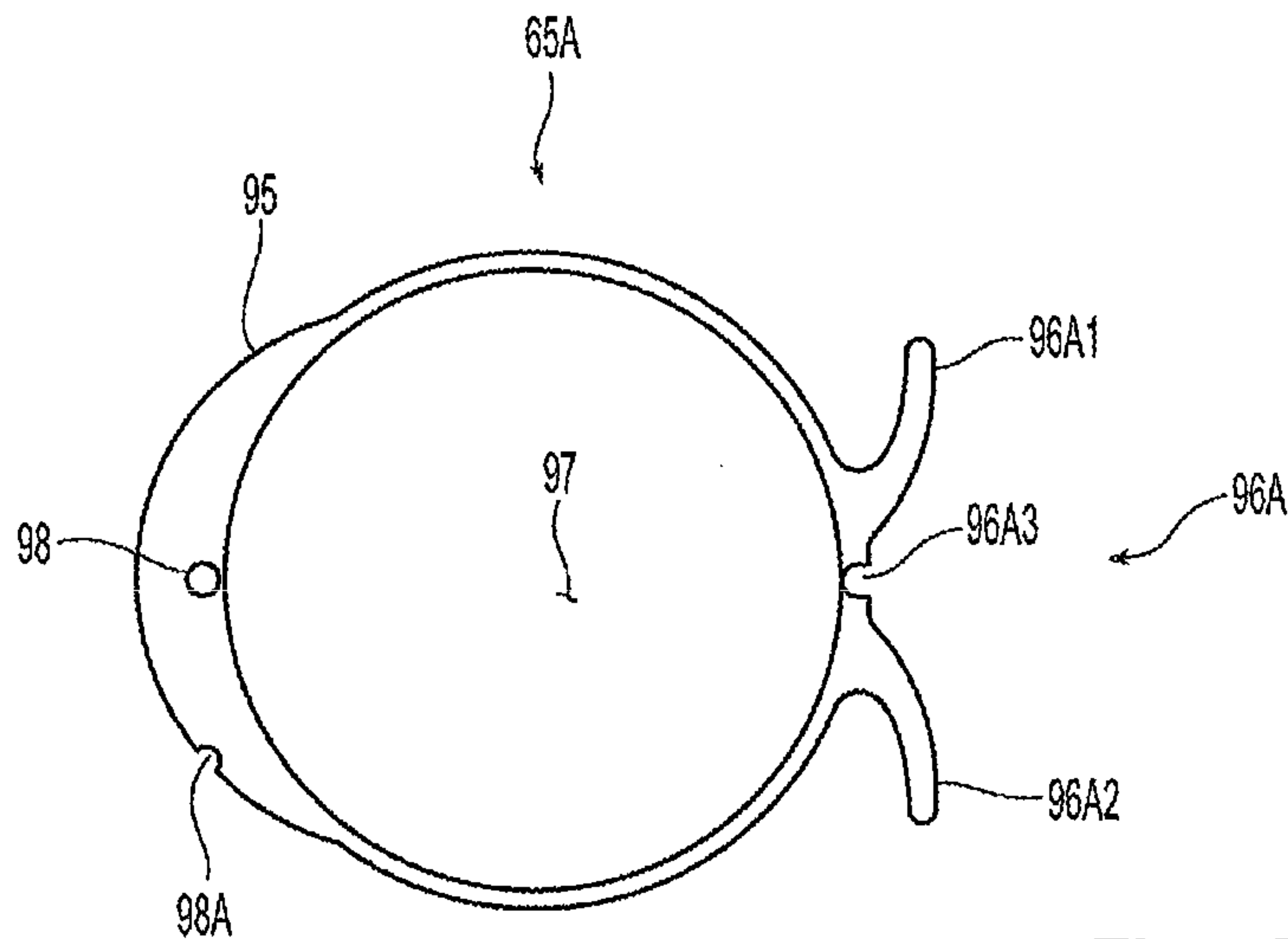


**Fig. 6C**

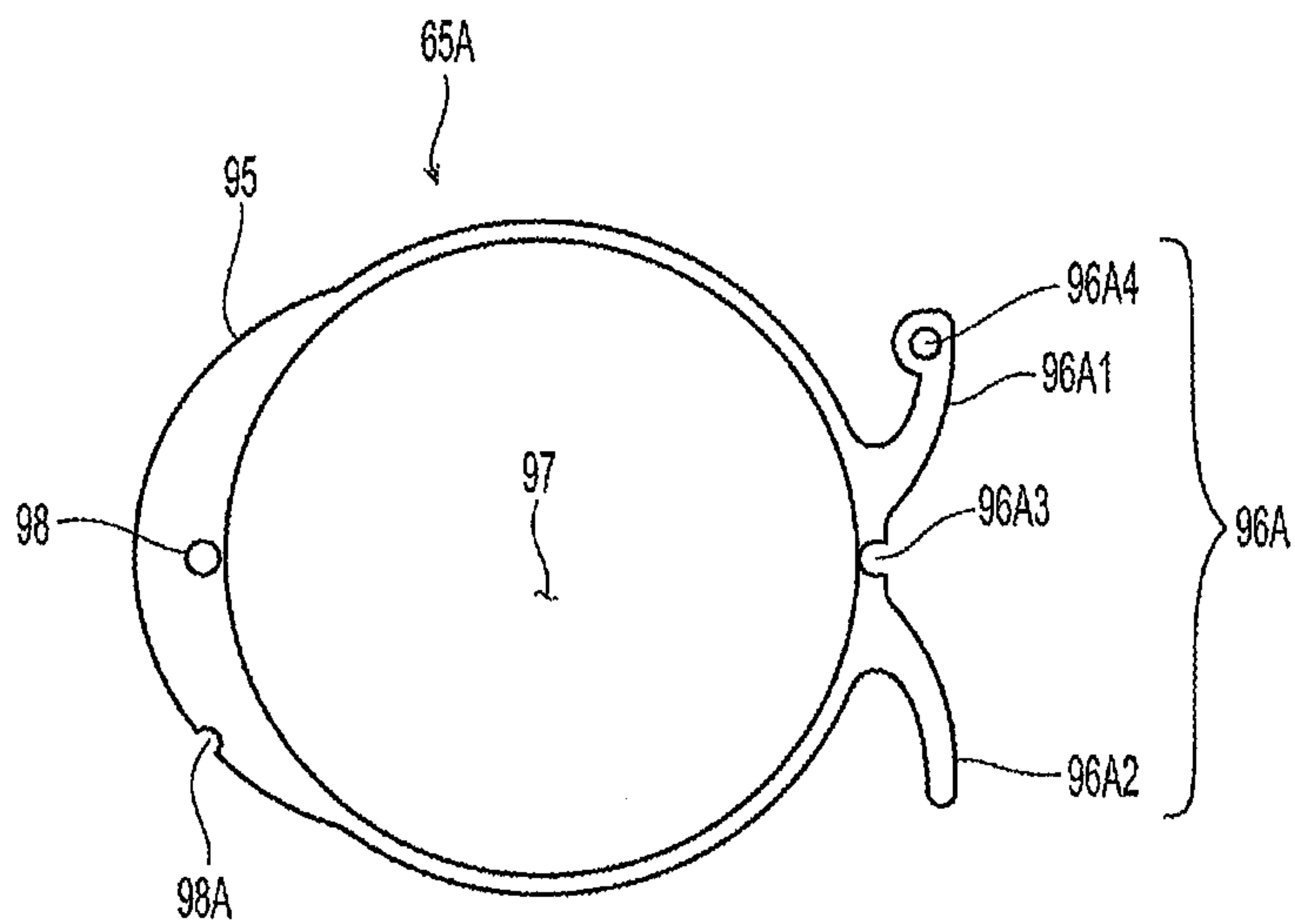
19/21



**Fig. 7A**

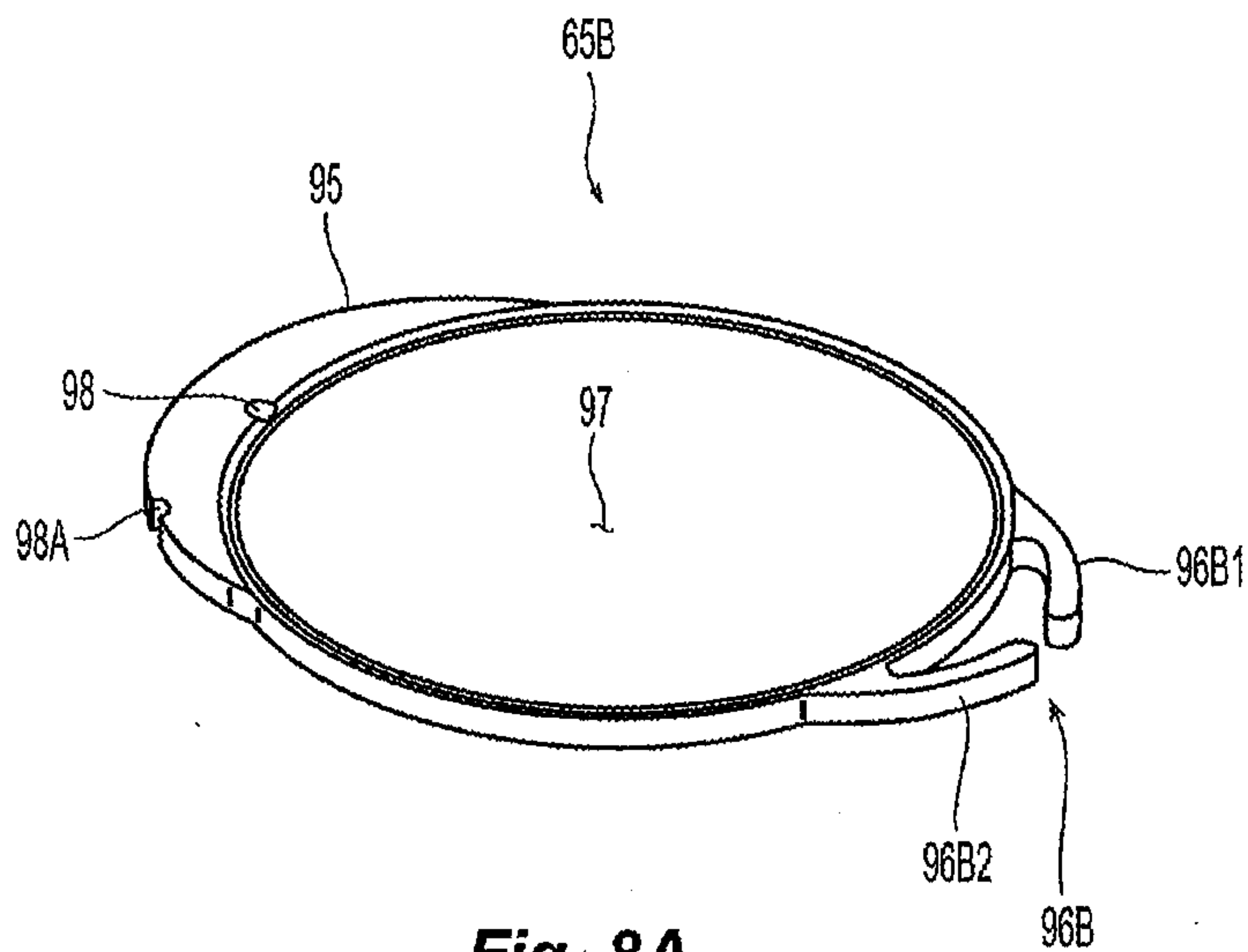


**Fig. 7B**

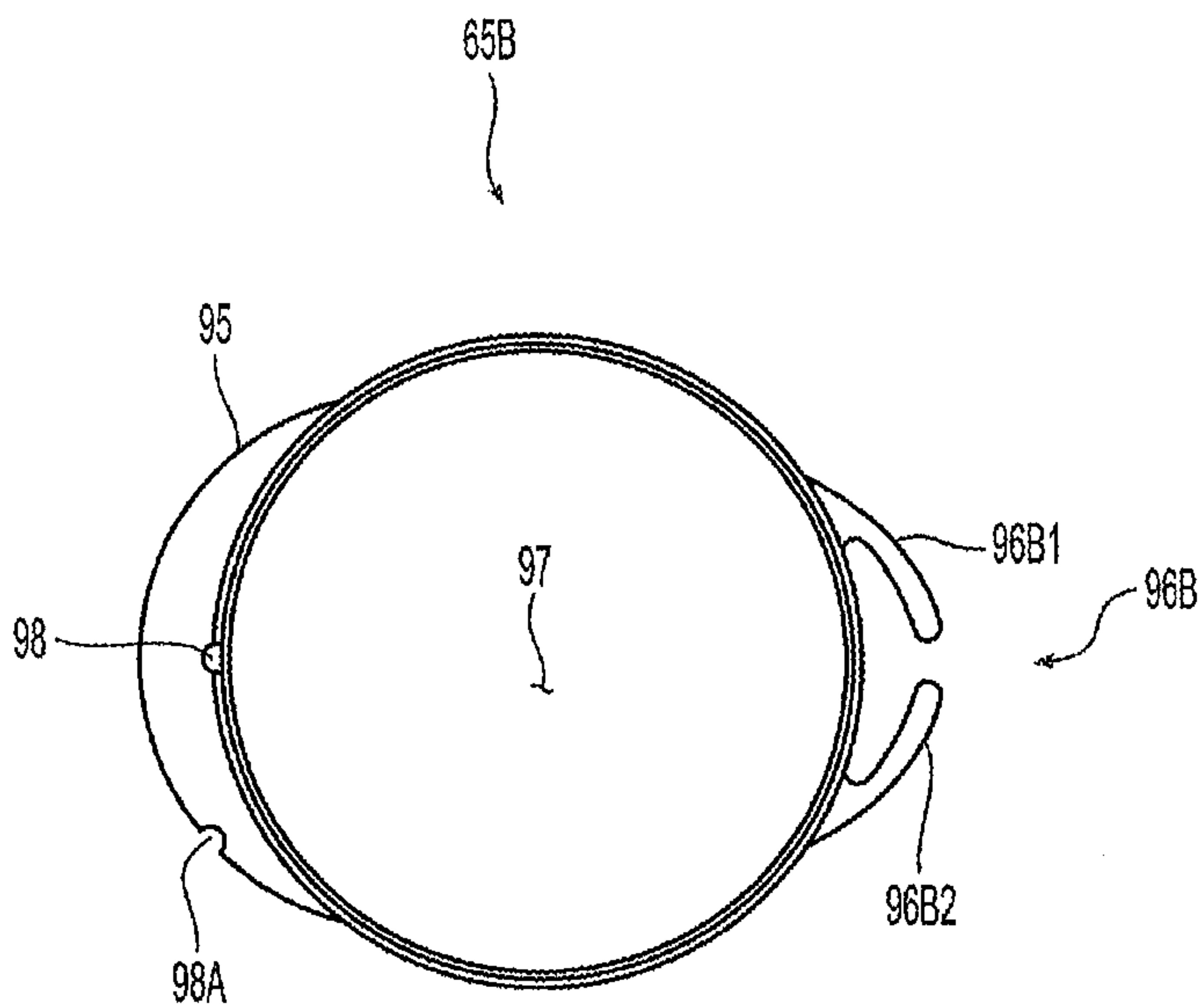


**Fig. 7C**

20/21

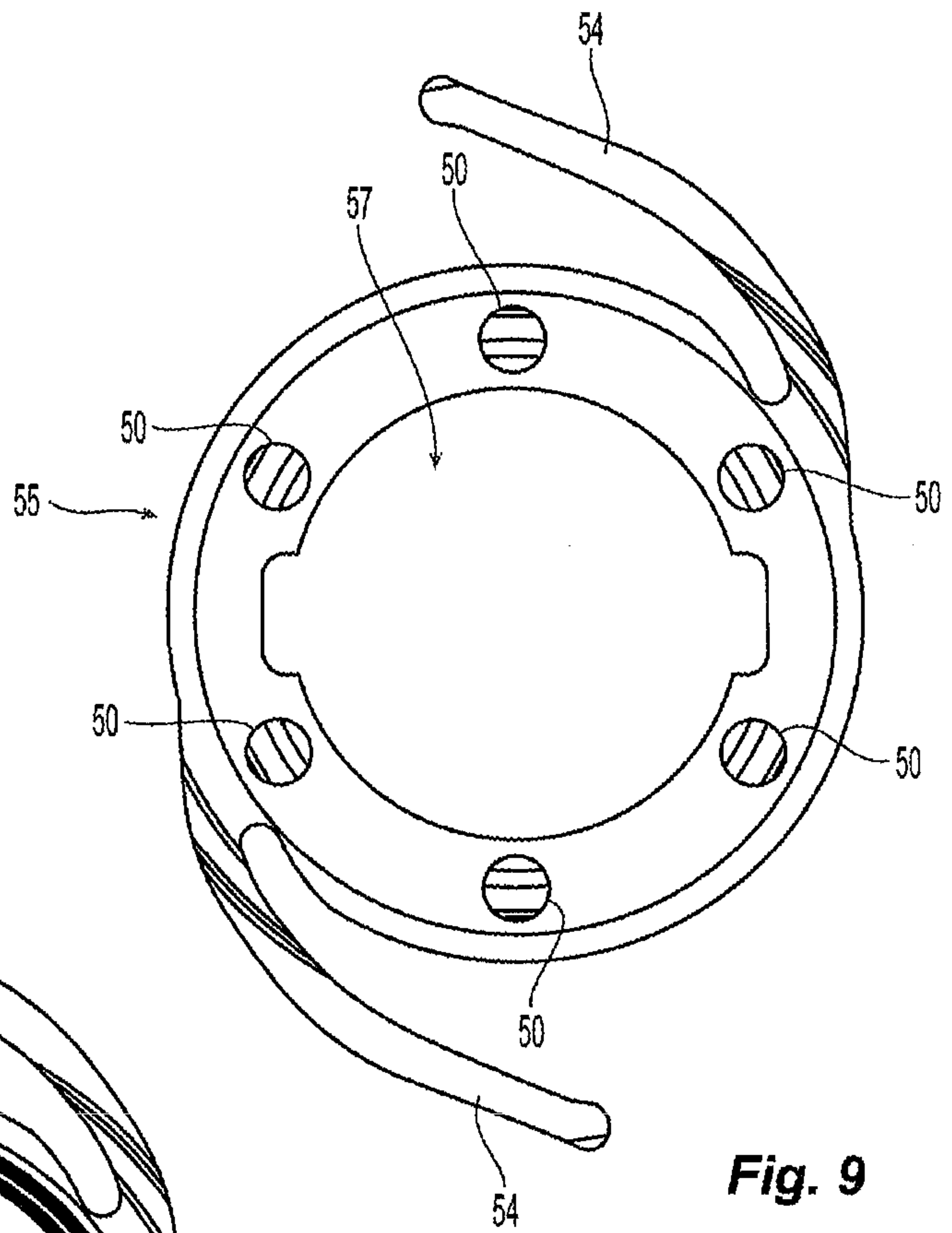


**Fig. 8A**

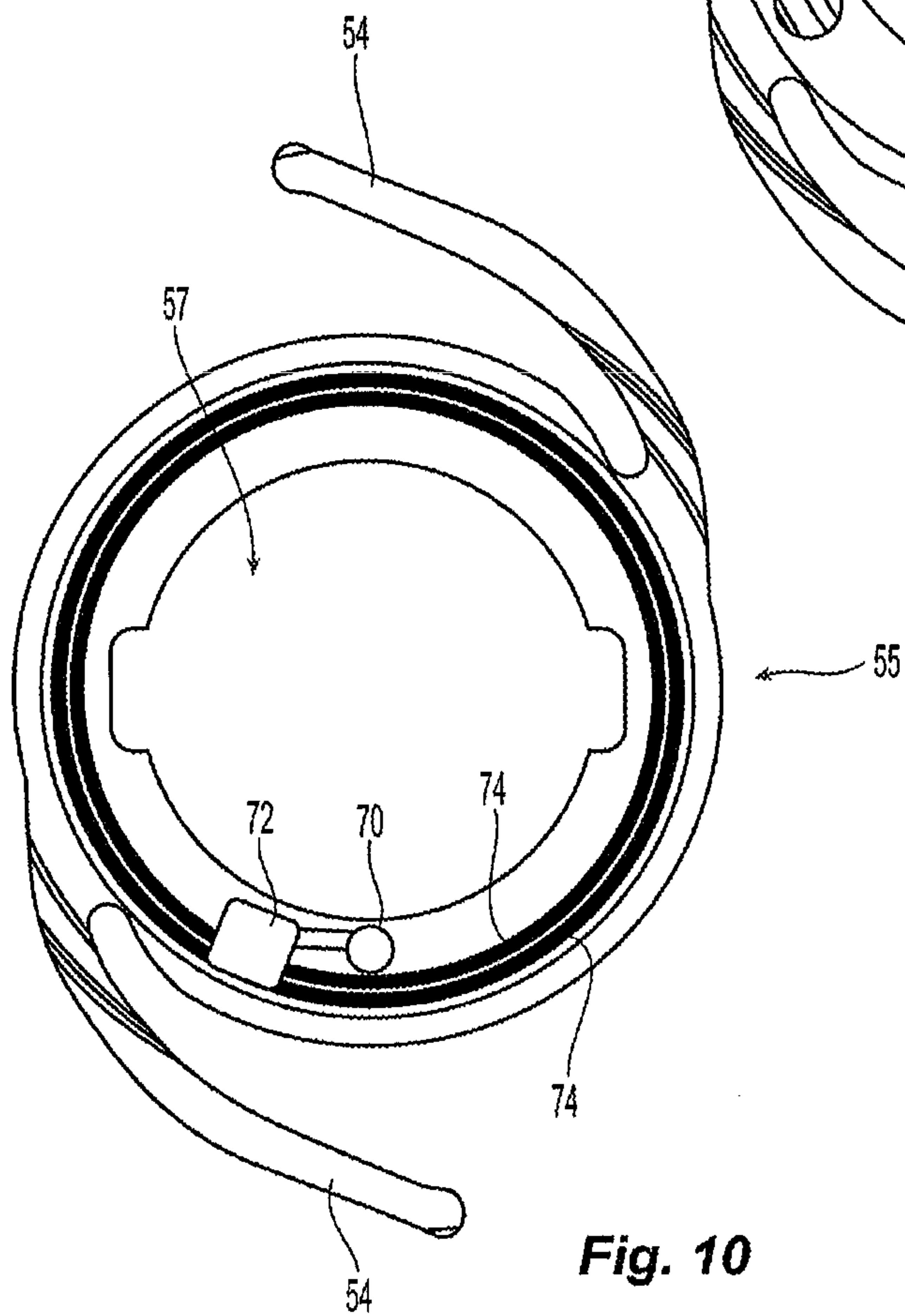


**Fig. 8B**

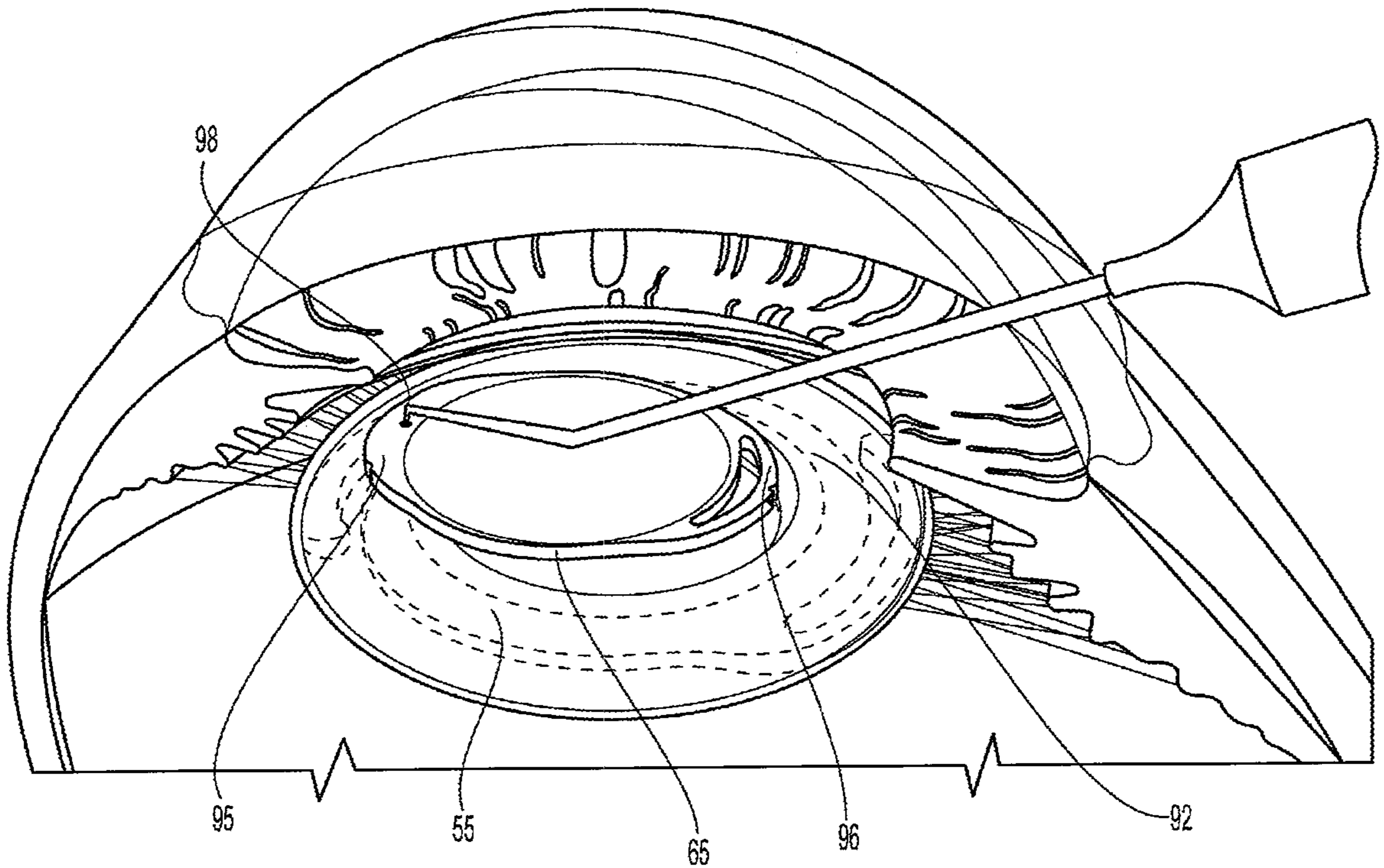
21/21



**Fig. 9**



**Fig. 10**



**Fig. 4F**