



US012035528B2

(12) **United States Patent**
Shin et al.

(10) **Patent No.:** **US 12,035,528 B2**

(45) **Date of Patent:** ***Jul. 9, 2024**

(54) **SEMICONDUCTOR DEVICE**

(71) Applicant: **SAMSUNG ELECTRONICS CO., LTD.**, Suwon-si (KR)

(72) Inventors: **Seung Jun Shin**, Yongin-si (KR); **Hyun Mog Park**, Seoul (KR); **Joong Shik Shin**, Yongin-si (KR)

(73) Assignee: **SAMSUNG ELECTRONICS CO., LTD.**, Suwon-si (KR)

(*) Notice: Subject to any disclaimer, the term of this patent is extended or adjusted under 35 U.S.C. 154(b) by 328 days.

This patent is subject to a terminal disclaimer.

(21) Appl. No.: **17/394,499**

(22) Filed: **Aug. 5, 2021**

(65) **Prior Publication Data**
US 2021/0366928 A1 Nov. 25, 2021

Related U.S. Application Data

(63) Continuation of application No. 16/892,384, filed on Jun. 4, 2020, now Pat. No. 11,114,463, which is a (Continued)

(30) **Foreign Application Priority Data**
Jul. 18, 2017 (KR) 10-2017-0090804

(51) **Int. Cl.**
H10B 43/27 (2023.01)
H01L 21/3213 (2006.01)
(Continued)

(52) **U.S. Cl.**
CPC **H10B 43/27** (2023.02); **H01L 21/3213** (2013.01); **H01L 21/76802** (2013.01);
(Continued)

(58) **Field of Classification Search**

CPC H10B 43/27; H10B 41/27; H10B 41/40; H10B 41/30; H10B 41/20; H10B 41/35;
(Continued)

(56) **References Cited**

U.S. PATENT DOCUMENTS

9,190,514 B2 11/2015 Lee et al.
9,306,040 B2 4/2016 Choi et al.
(Continued)

FOREIGN PATENT DOCUMENTS

CN 105359270 A 2/2016
CN 106449648 A 2/2017
(Continued)

OTHER PUBLICATIONS

Korean Notice of Allowance dated Dec. 22, 2021 for corresponding KR 10-2017-0090804.

(Continued)

Primary Examiner — Allison Bernstein

Assistant Examiner — Margaret B Hayes

(74) *Attorney, Agent, or Firm* — Muir Patent Law, PLLC

(57) **ABSTRACT**

A semiconductor device includes gate electrodes stacked along a direction perpendicular to an upper surface of a substrate, the gate electrodes extending to different lengths in a first direction, and each gate electrode including subgate electrodes spaced apart from each other in a second direction perpendicular to the first direction, and gate connection portions connecting subgate electrodes of a same gate electrode of the gate electrodes to each other, channels extending through the gate electrodes perpendicularly to the upper surface of the substrate, and dummy channels extending through the gate electrodes perpendicularly to the upper surface of the substrate, the dummy channels including first dummy channels arranged in rows and columns, and second (Continued)

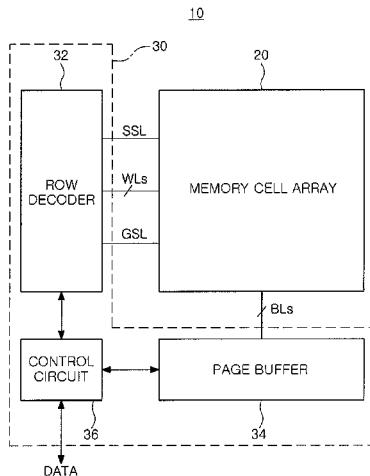

dummy channels arranged between the first dummy channels in a region including the gate connection portions.

19 Claims, 30 Drawing Sheets

Related U.S. Application Data

continuation of application No. 15/933,544, filed on Mar. 23, 2018, now Pat. No. 10,680,007.

(51) **Int. Cl.**

- H01L 21/768* (2006.01)
- H01L 29/417* (2006.01)
- H01L 29/66* (2006.01)
- H01L 29/78* (2006.01)
- H01L 29/788* (2006.01)
- H01L 29/792* (2006.01)
- H10B 41/27* (2023.01)
- H10B 41/40* (2023.01)
- H10B 43/10* (2023.01)
- H10B 43/35* (2023.01)
- H10B 43/40* (2023.01)
- H10B 43/50* (2023.01)

(52) **U.S. Cl.**

CPC .. *H01L 21/76877* (2013.01); *H01L 29/41775* (2013.01); *H01L 29/66666* (2013.01); *H01L 29/7827* (2013.01); *H01L 29/7889* (2013.01); *H01L 29/7926* (2013.01); *H10B 41/27* (2023.02); *H10B 41/40* (2023.02); *H10B 43/10* (2023.02); *H10B 43/35* (2023.02); *H10B 43/40* (2023.02); *H10B 43/50* (2023.02)

(58) **Field of Classification Search**

CPC H10B 43/10; H10B 43/35; H10B 43/40; H10B 43/50; H10B 43/30; H01L 21/3213; H01L 21/76802; H01L 21/76877; H01L 21/76897; H01L 29/41775; H01L 29/66666; H01L 29/7827; H01L 29/7889; H01L 29/7926; H01L 29/732

See application file for complete search history.

(56) **References Cited**

U.S. PATENT DOCUMENTS

- 9,306,041 B2 4/2016 Hwang et al.
- 9,425,205 B2 8/2016 Shimura

- 9,425,208 B2 8/2016 Kim et al.
- 9,496,269 B1 11/2016 Liaw
- 9,716,104 B2 7/2017 Kim et al.
- 10,026,746 B2 7/2018 Lee et al.
- 10,312,191 B2 6/2019 Jung et al.
- 11,114,463 B2* 9/2021 Shin H10B 43/35
- 2014/0199815 A1 7/2014 Hwang et al.
- 2015/0069377 A1 3/2015 Rabkin et al.
- 2015/0115348 A1 4/2015 Nam et al.
- 2015/0137216 A1 5/2015 Lee et al.
- 2015/0318301 A1 11/2015 Lee et al.
- 2015/0340374 A1 11/2015 Jung et al.
- 2015/0372101 A1* 12/2015 Lee H10B 43/27
257/314
- 2016/0049423 A1 2/2016 Yoo et al.
- 2016/0064345 A1 3/2016 Shimoda et al.
- 2016/0079254 A1 3/2016 Shimura
- 2016/0225785 A1 8/2016 Kim et al.
- 2017/0047339 A1 2/2017 Cernea
- 2017/0062526 A1 3/2017 Lu et al.
- 2017/0077137 A1 3/2017 Kim et al.
- 2017/0098658 A1* 4/2017 Matsuda H10B 41/10
- 2017/0170191 A1 6/2017 Lee et al.
- 2017/0200676 A1 7/2017 Jeong et al.
- 2018/0261618 A1 9/2018 Lee et al.
- 2019/0019807 A1 1/2019 Gu et al.
- 2019/0027490 A1 1/2019 Shin et al.
- 2019/0043880 A1 2/2019 Lee et al.

FOREIGN PATENT DOCUMENTS

- CN 106653756 A 5/2017
- CN 106920794 A 7/2017
- KR 10-2015-0116995 A 10/2015
- KR 10-2015-0136156 A 12/2015
- KR 10-2015-0140067 A 12/2015
- KR 10-2016-0000503 A 1/2016
- KR 10-2016-0020019 A 2/2016
- KR 10-2017-0018207 A 2/2017
- KR 10-2017-0031288 A 3/2017

OTHER PUBLICATIONS

Search Report and Written Opinion, issued Dec. 20, 2018, by the Singapore Intellectual Property Office for corresponding application SG 10201805477Y.

Indian Office action dated Nov. 21, 2019 for corresponding application IN 201814025669.

Chinese Office action issued Feb. 27, 2023, for corresponding CN 201810725247.8.

* cited by examiner

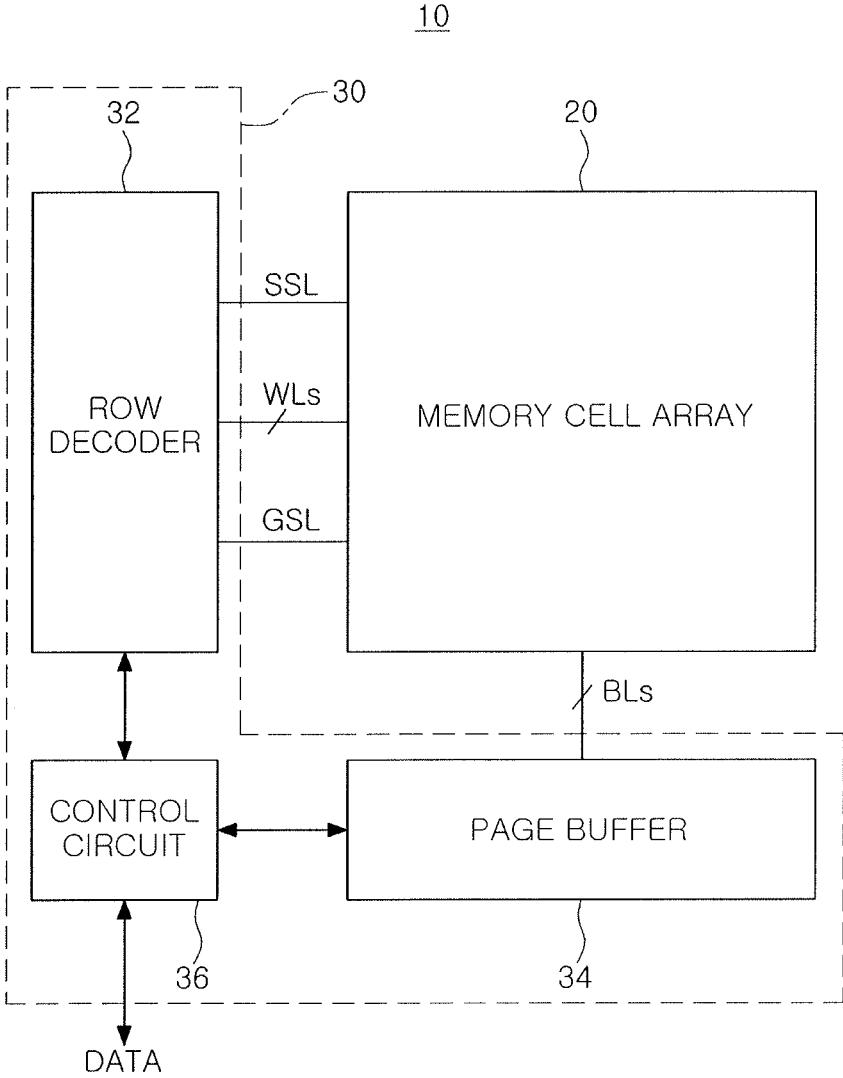

FIG. 1

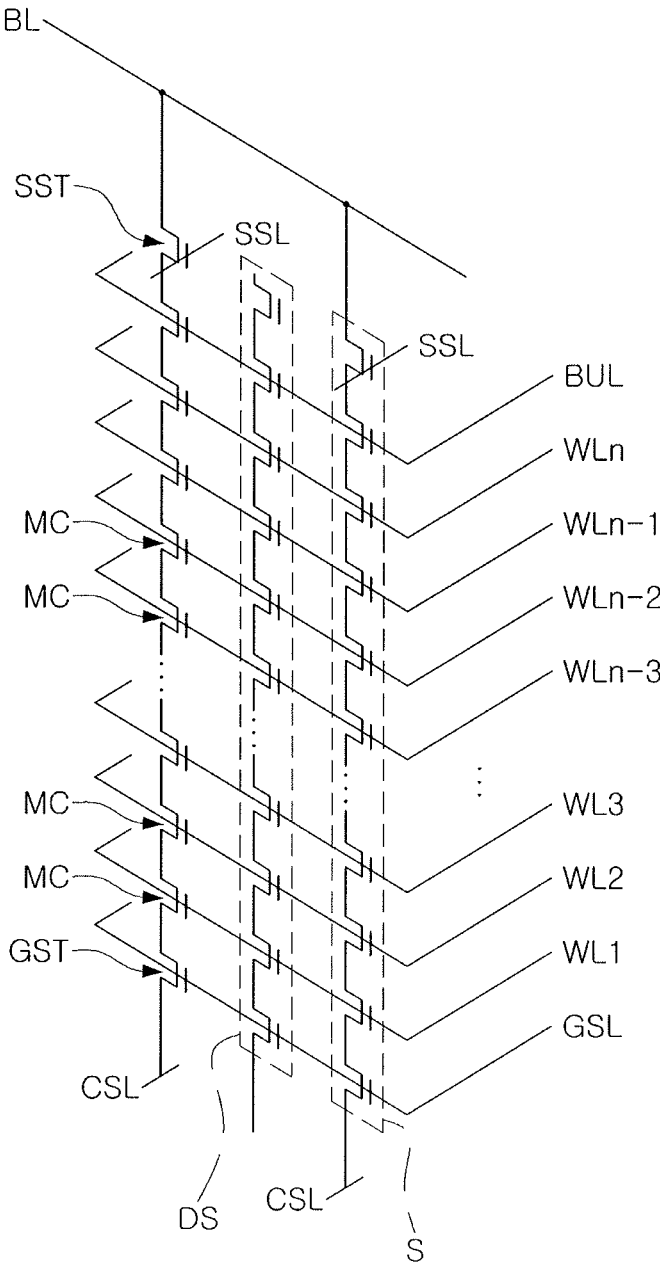

FIG. 2

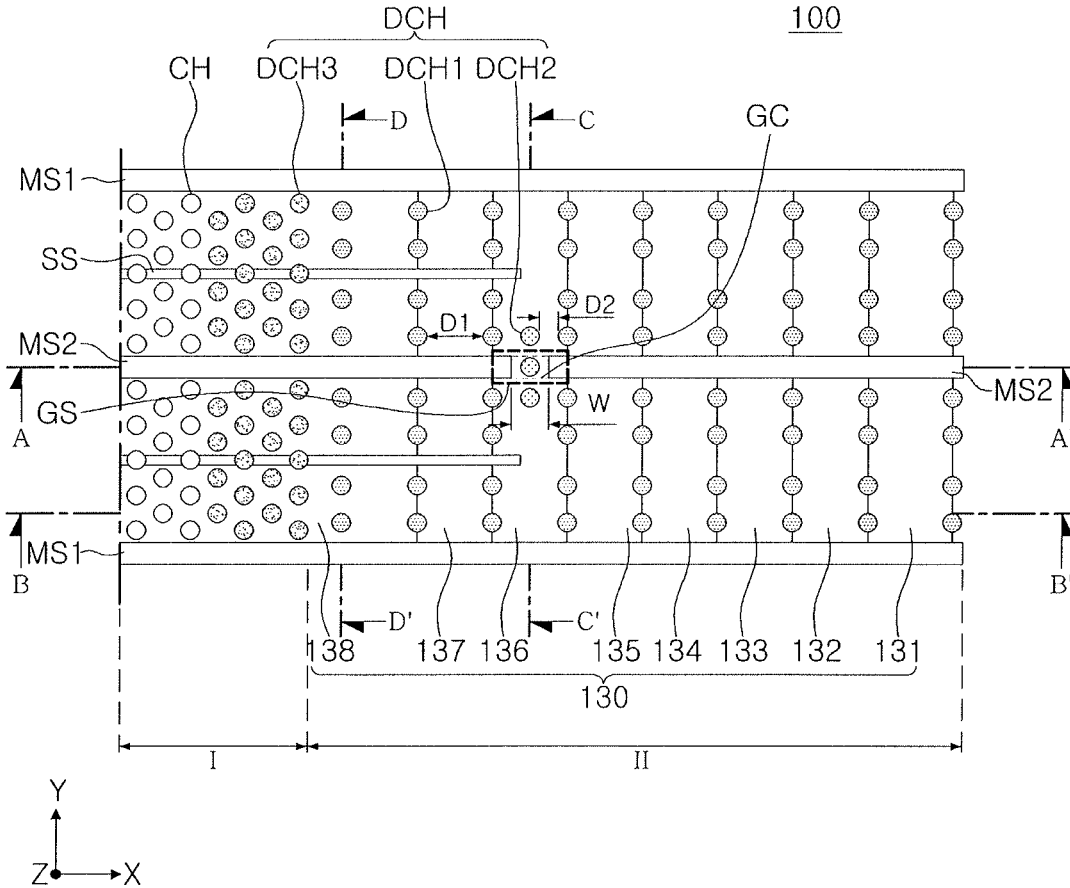

FIG. 3

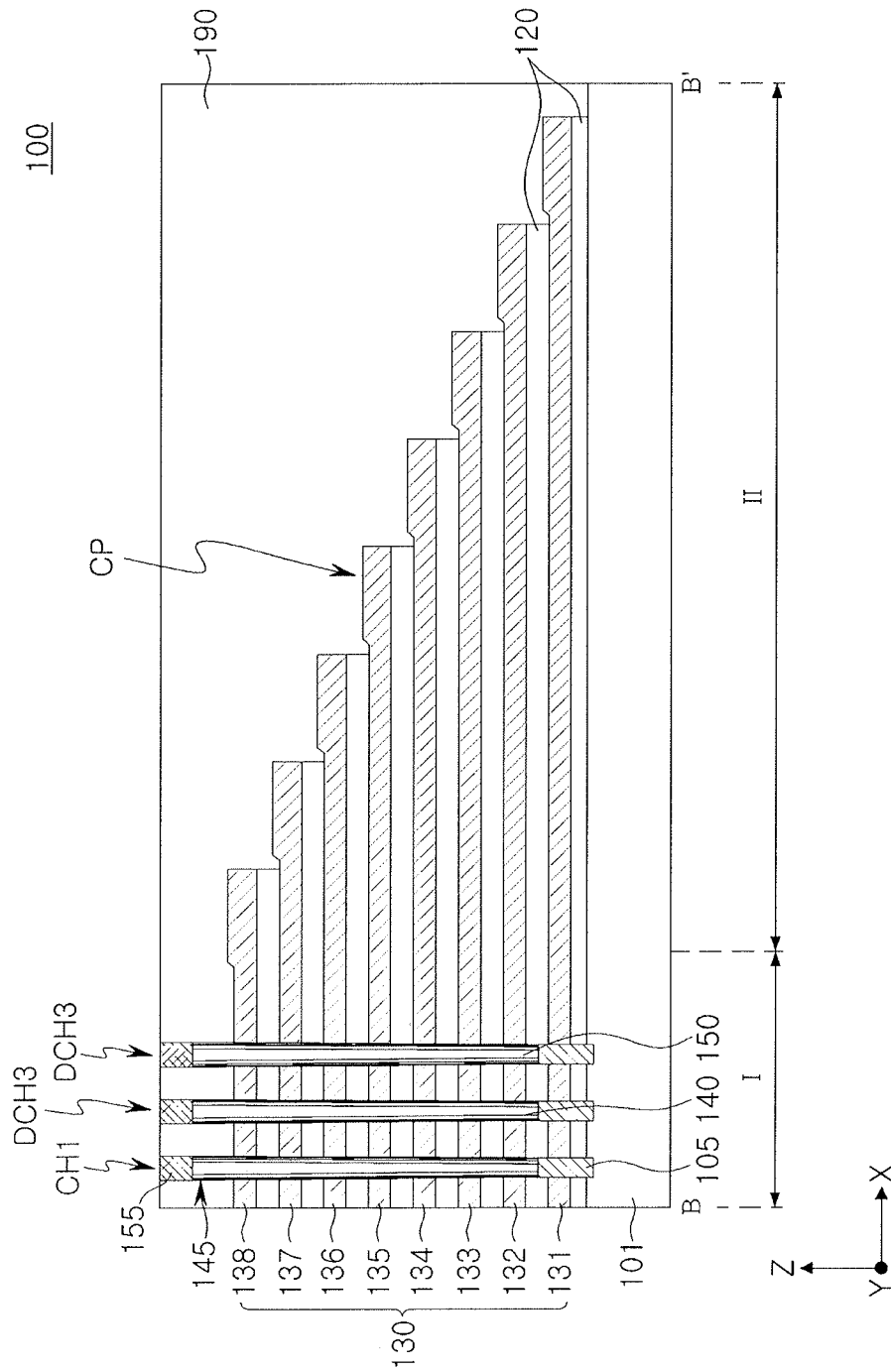

FIG. 4B

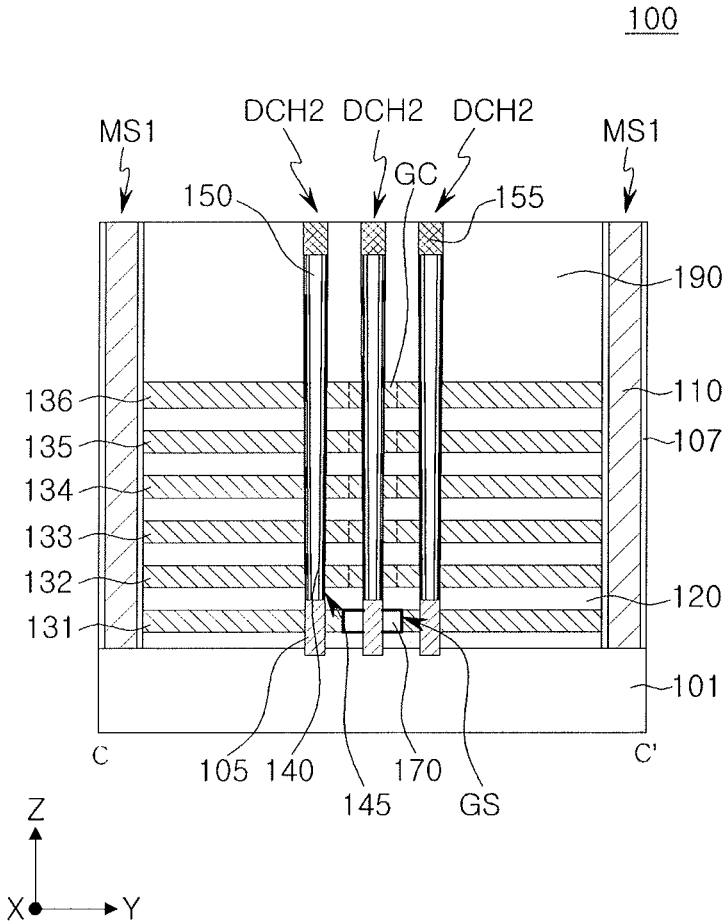

FIG. 4C

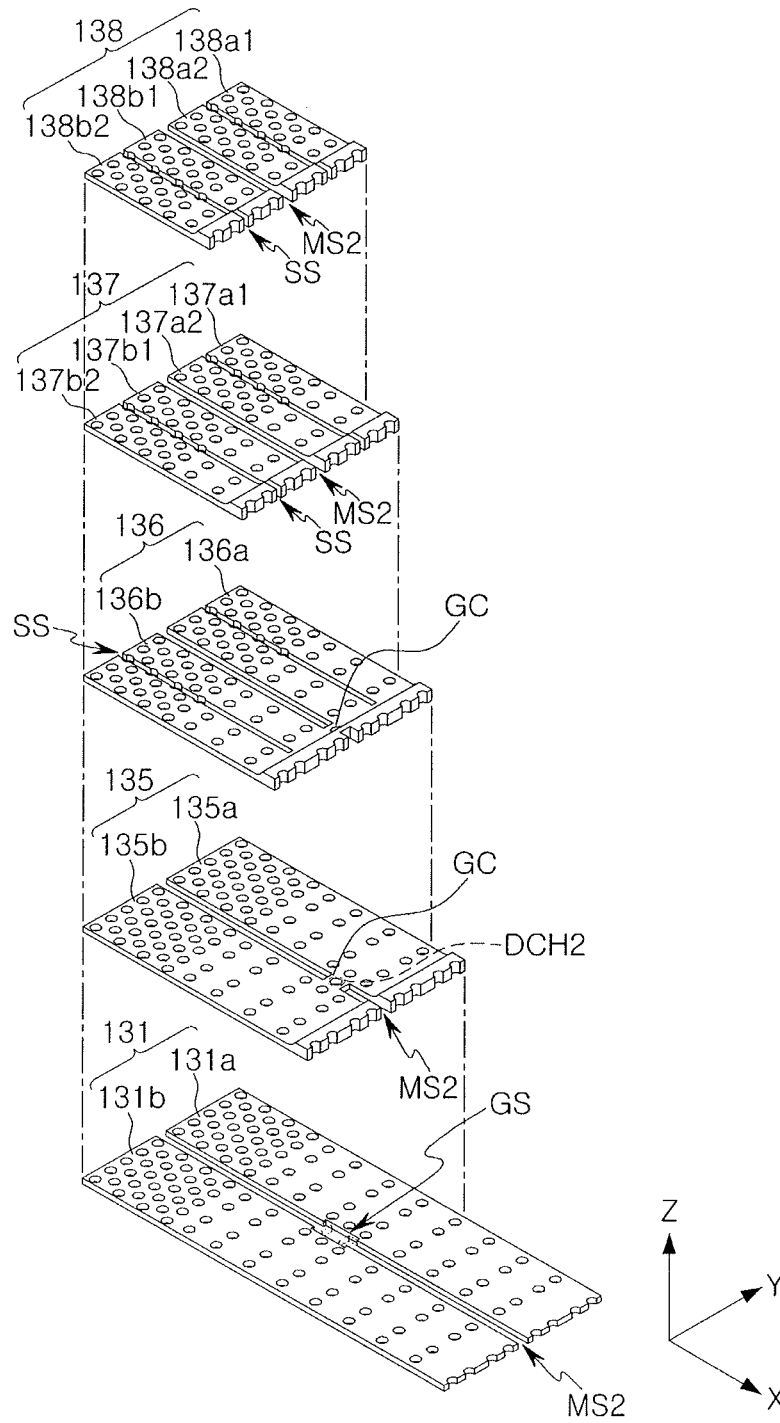

FIG. 5

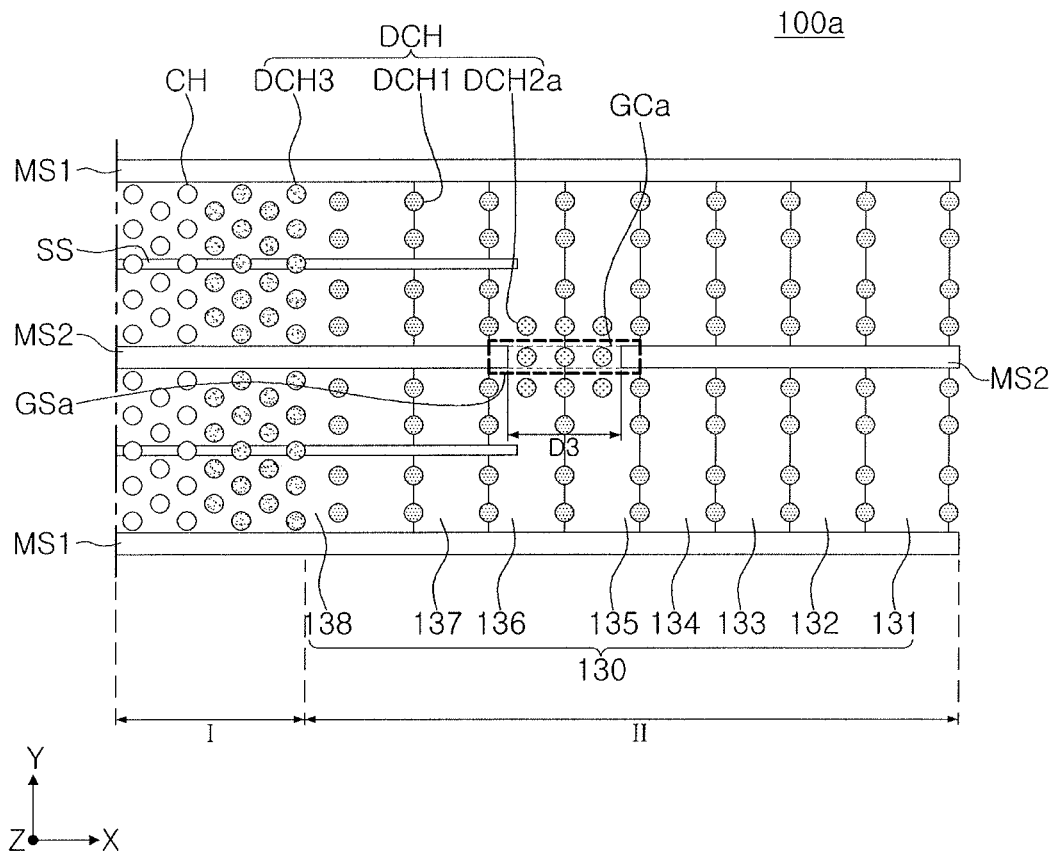

FIG. 6

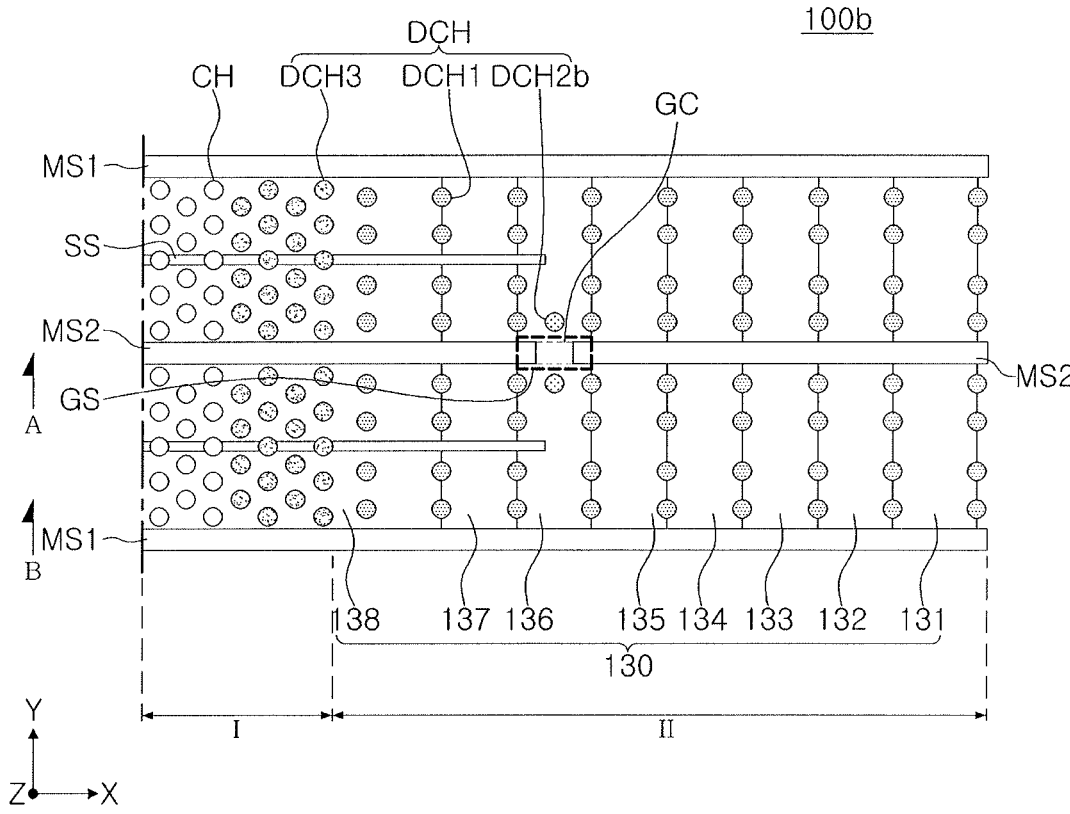

FIG. 7

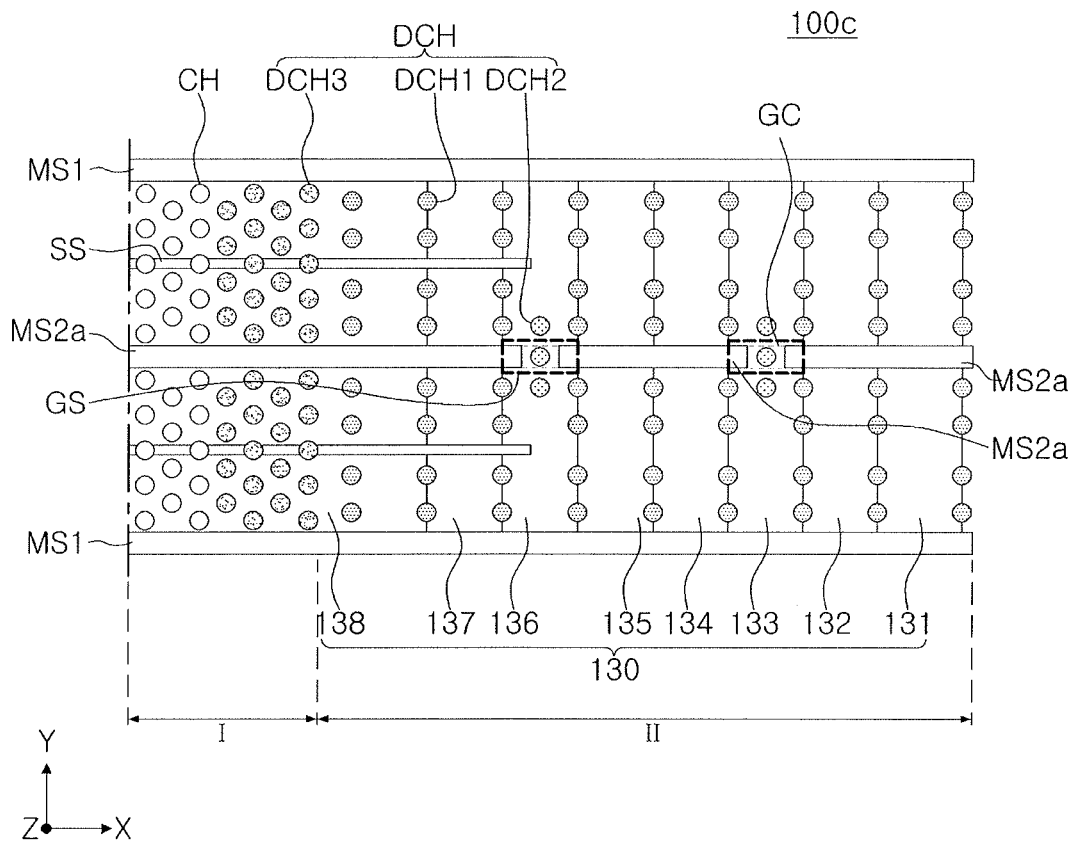

FIG. 8

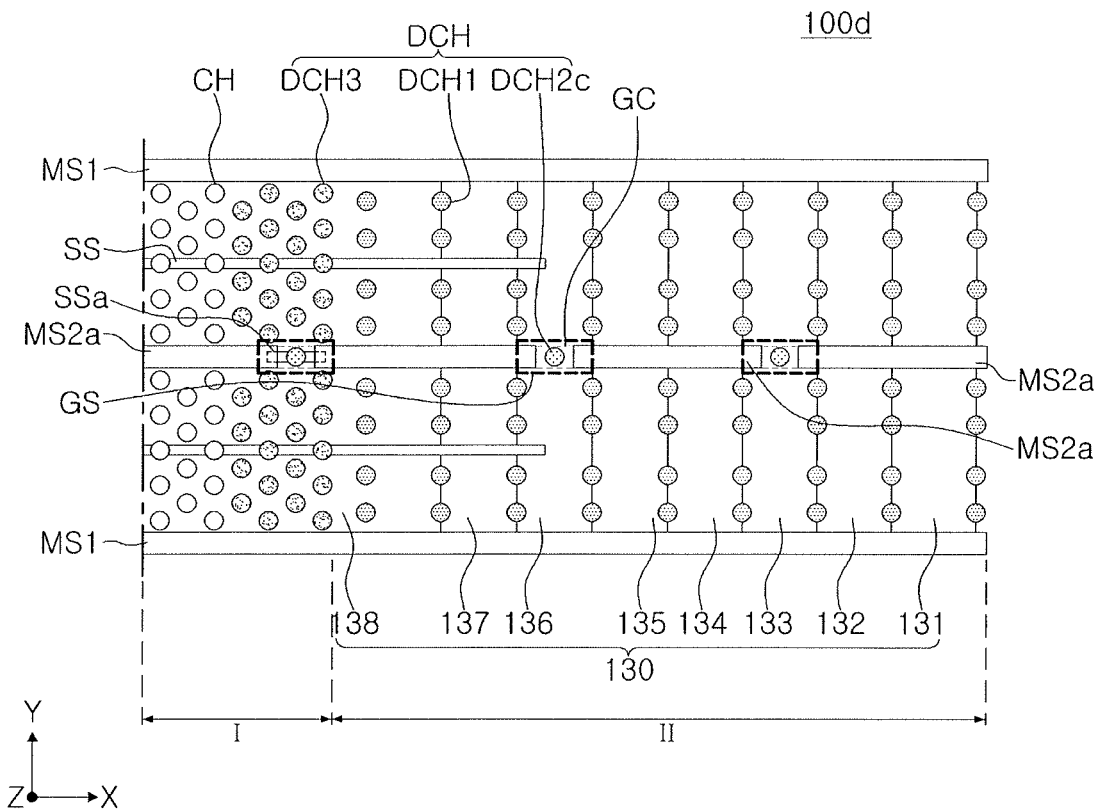

FIG. 9

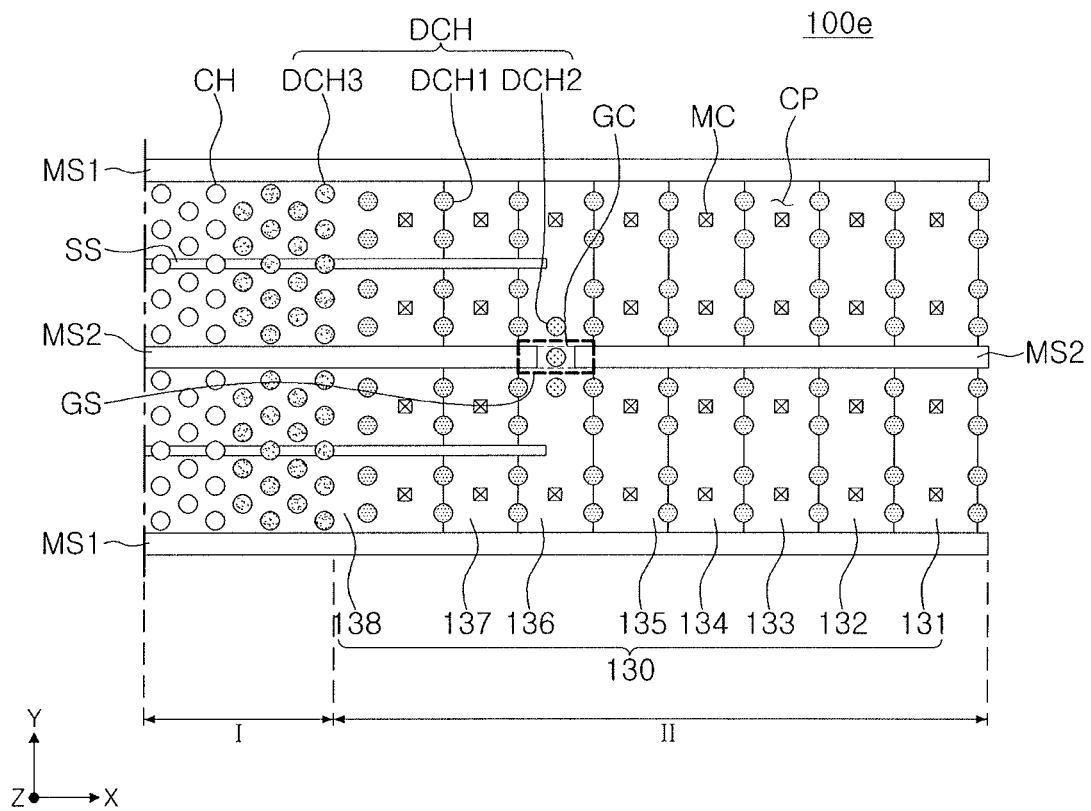

FIG. 10

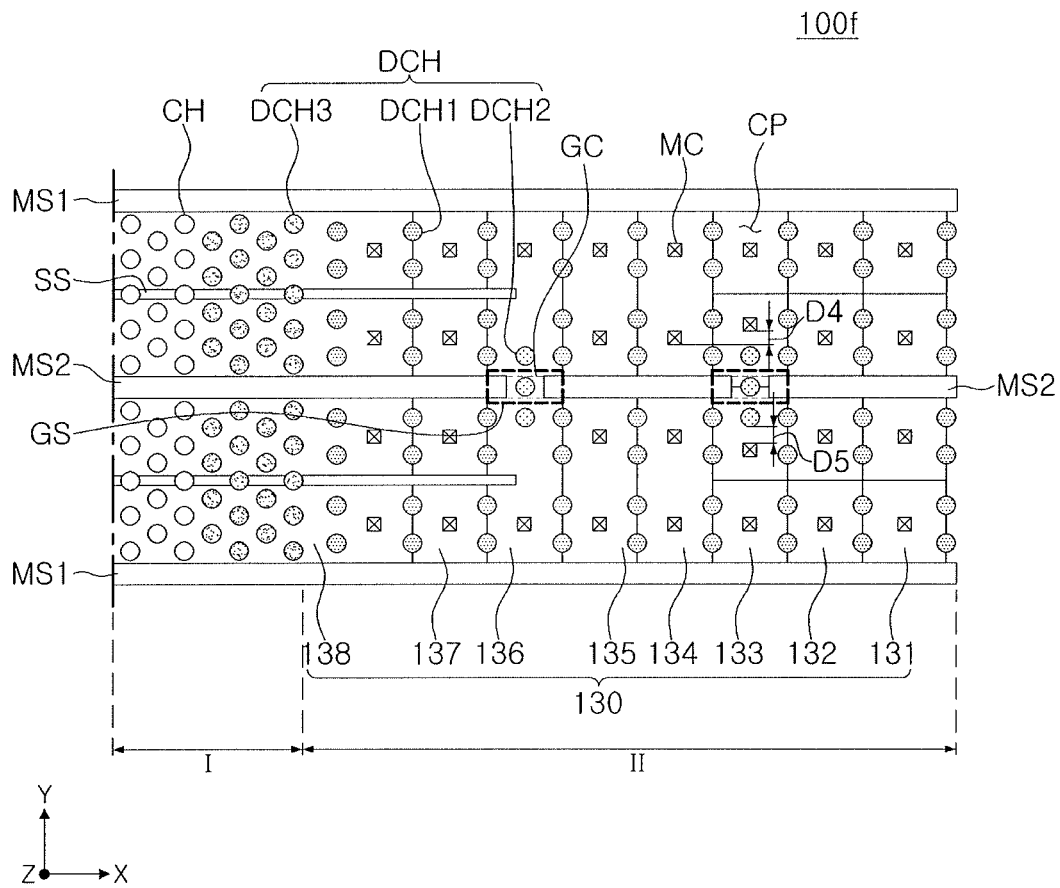

FIG. 11

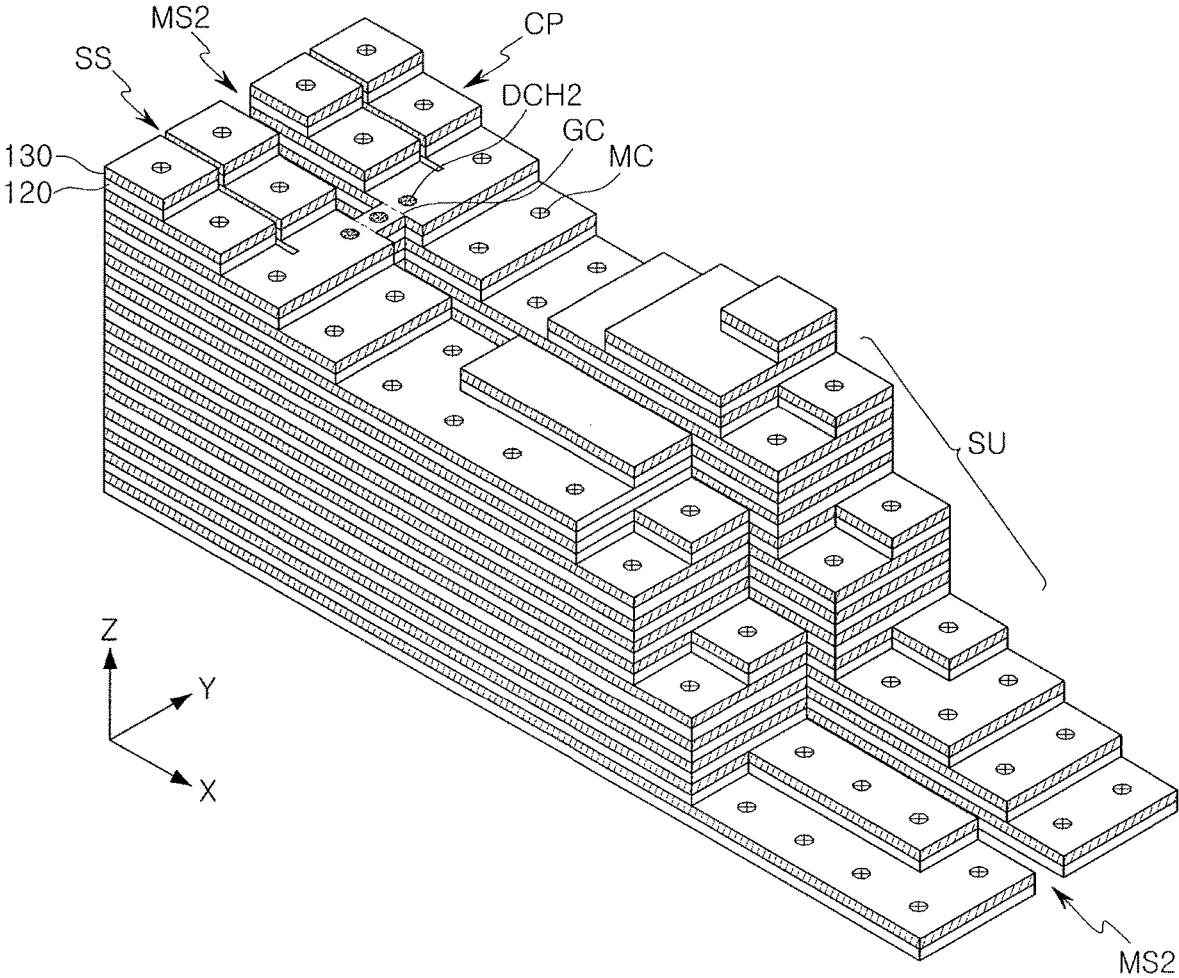

FIG. 12

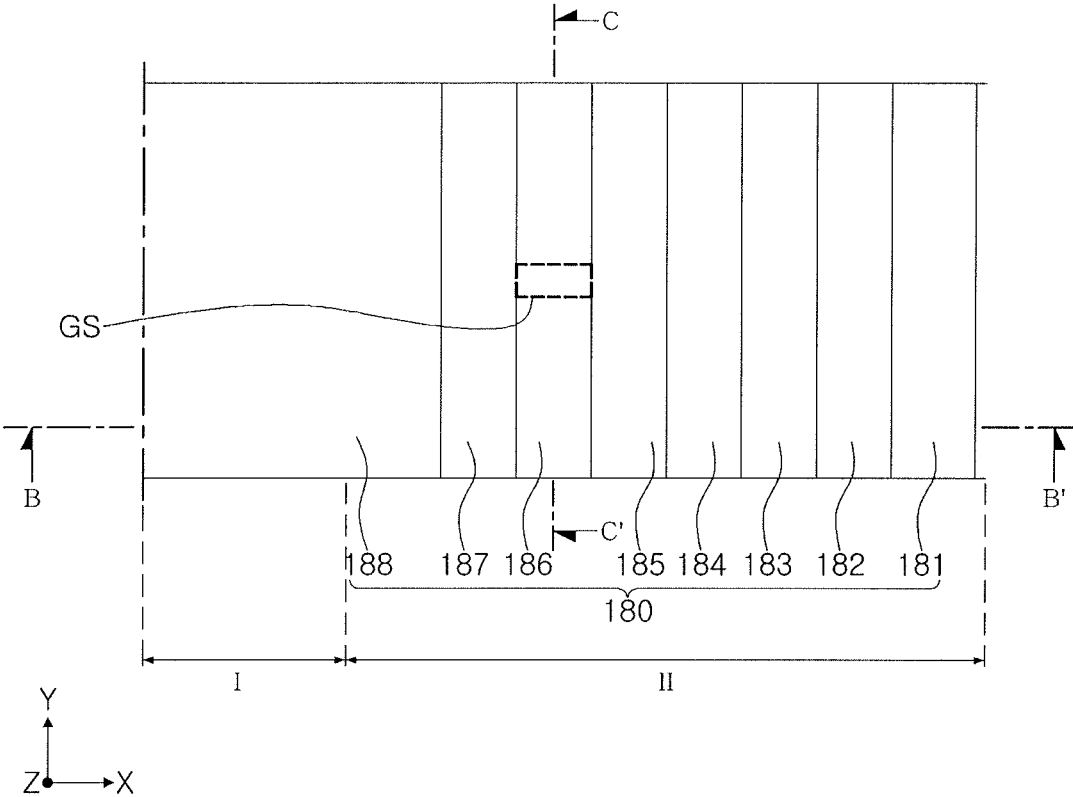

FIG. 13A

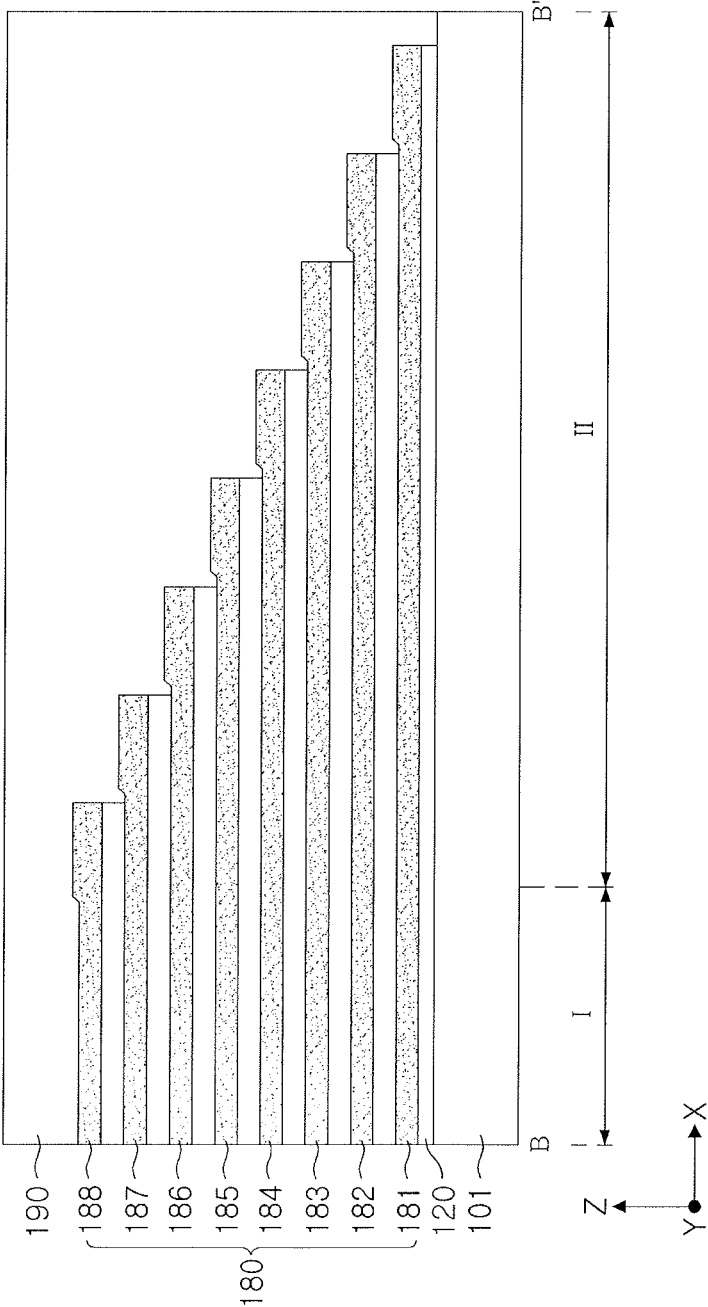

FIG. 13B

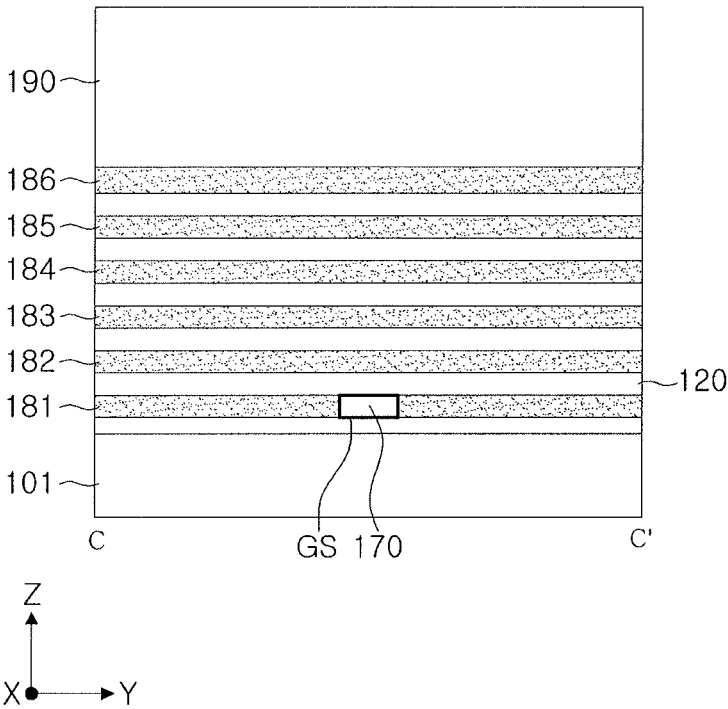

FIG. 13C

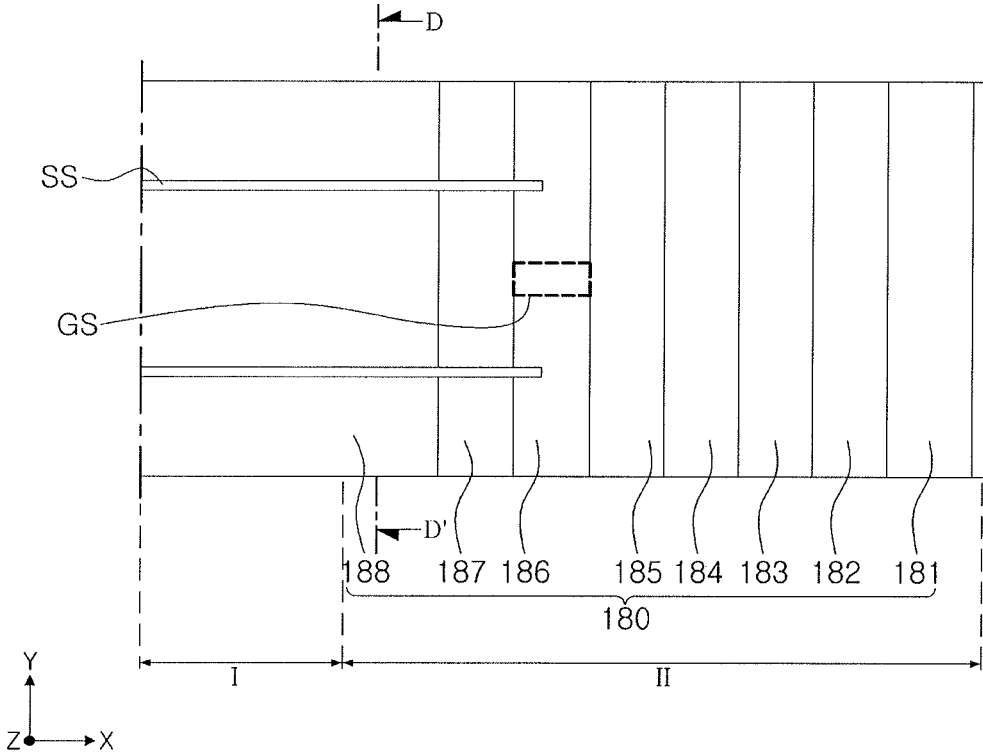

FIG. 14A

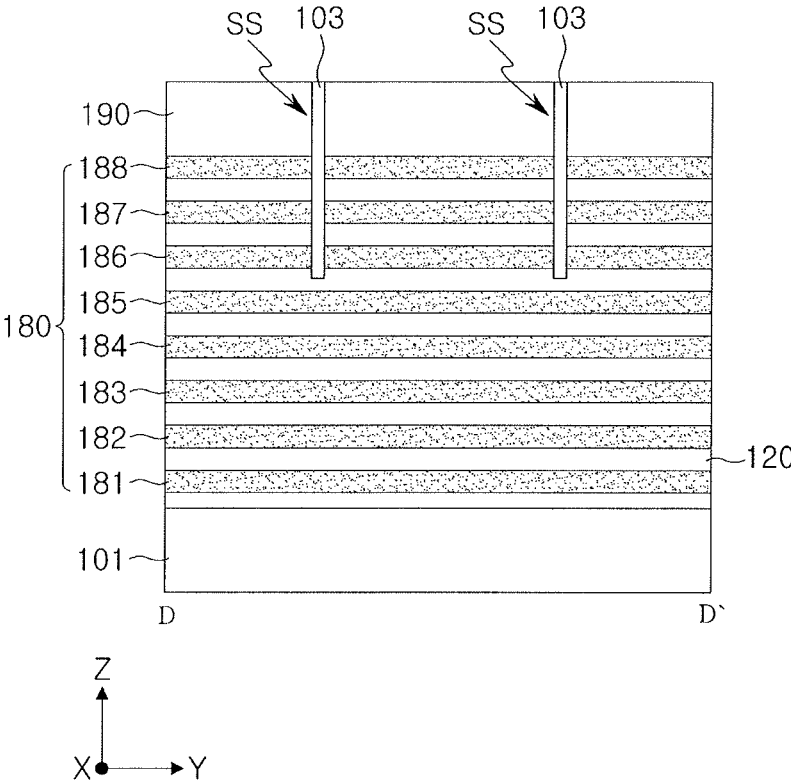

FIG. 14B

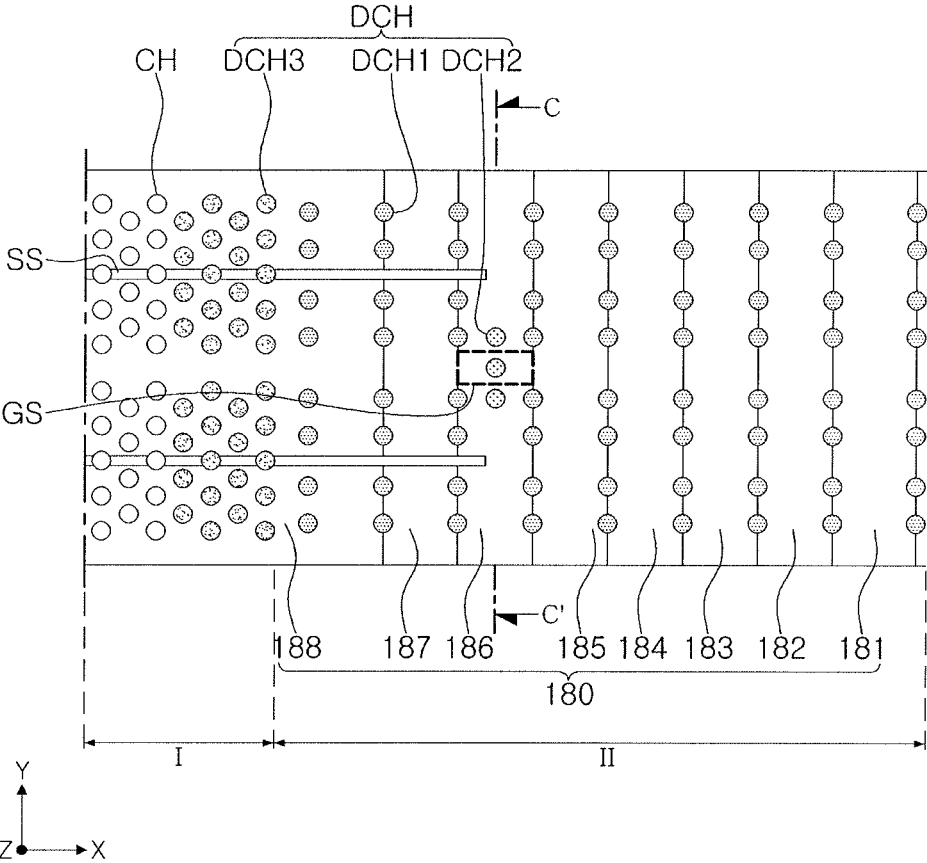

FIG. 15A

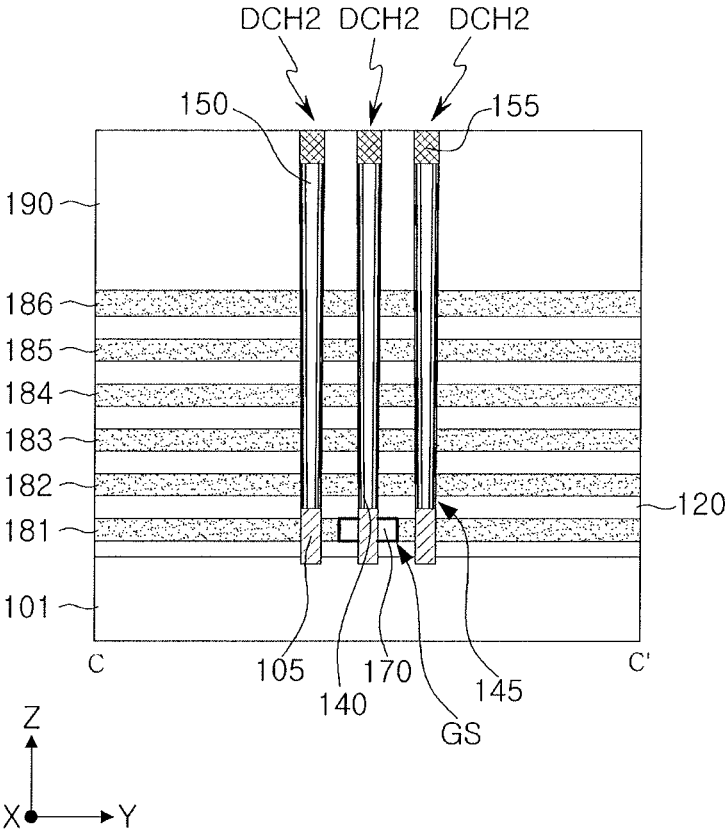

FIG. 15B

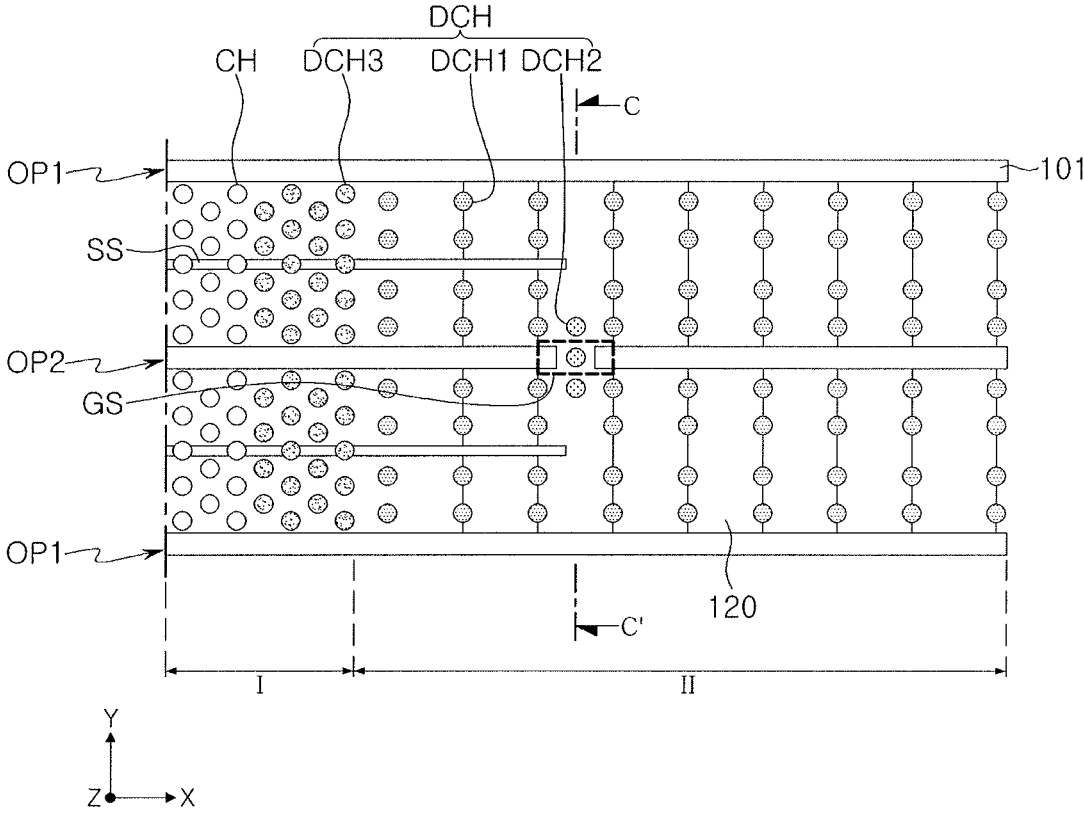

FIG. 16A

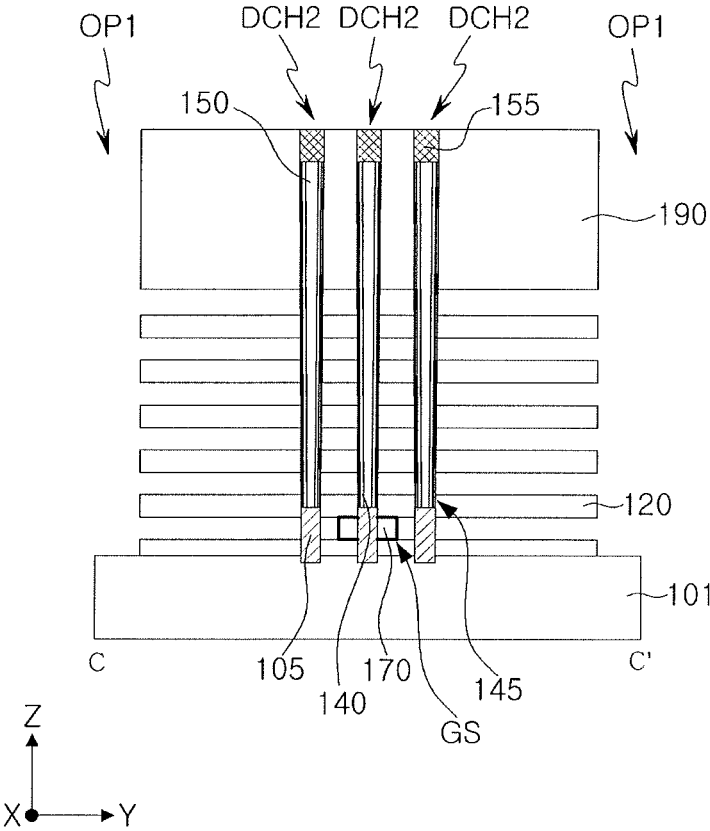

FIG. 16B

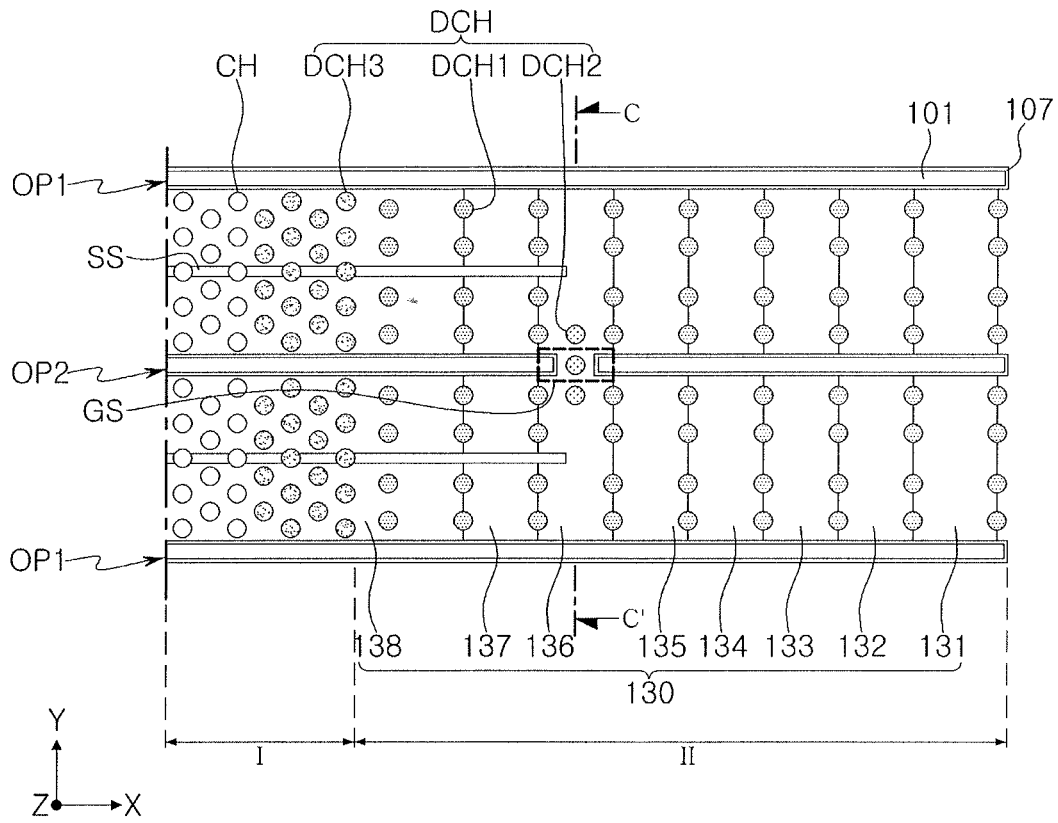

FIG. 17A

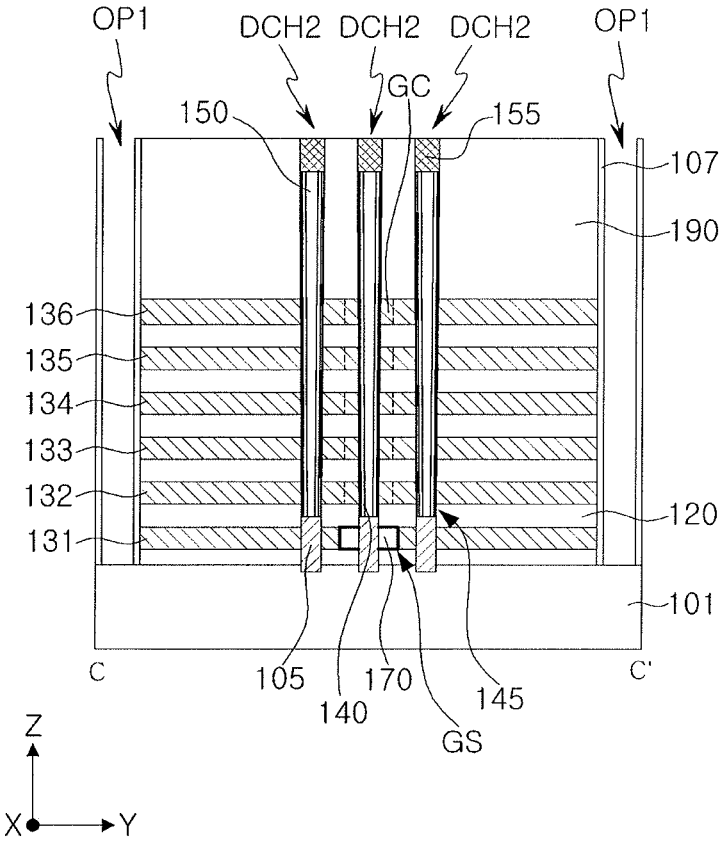

FIG. 17B

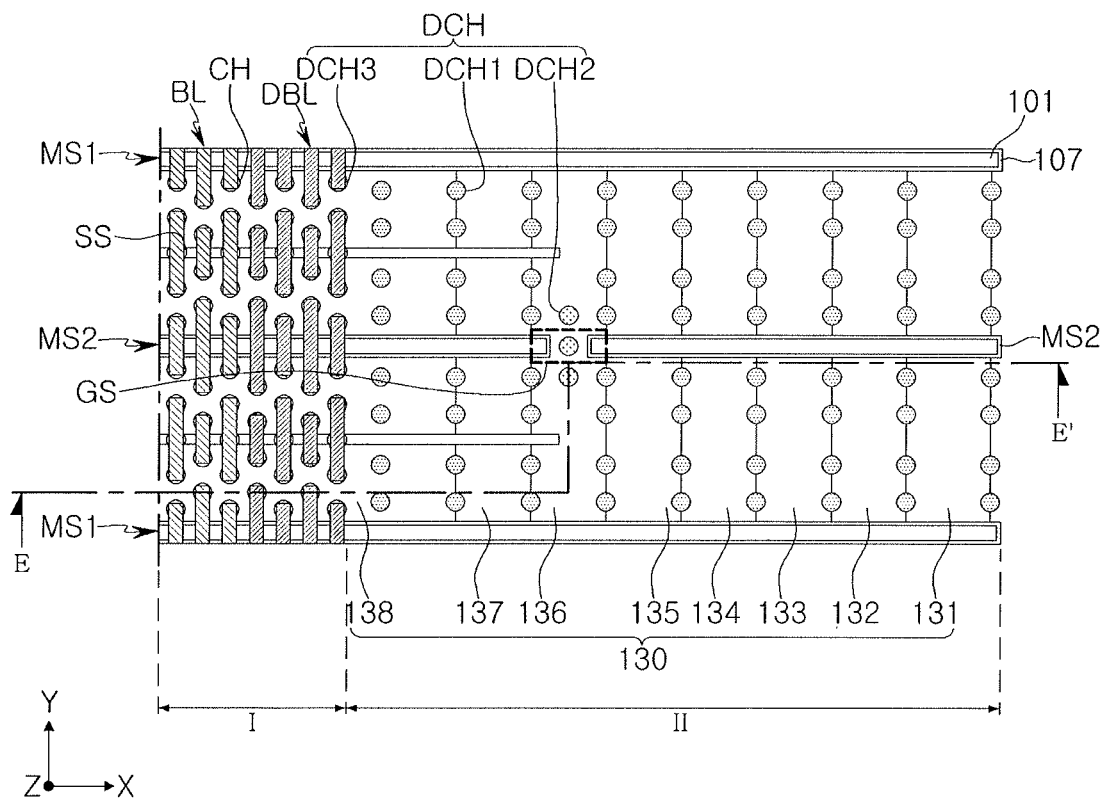

FIG. 18A

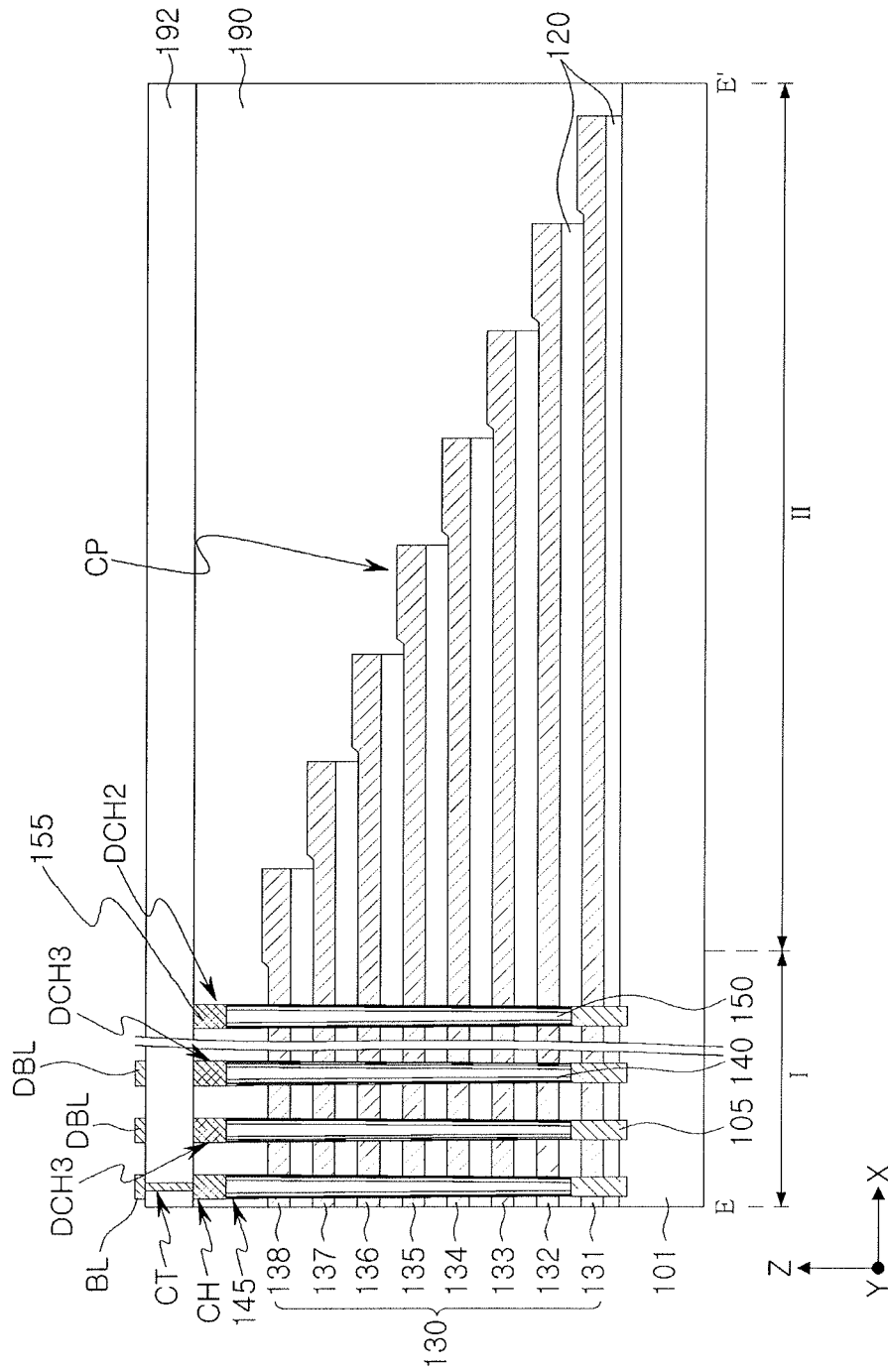

FIG. 18B

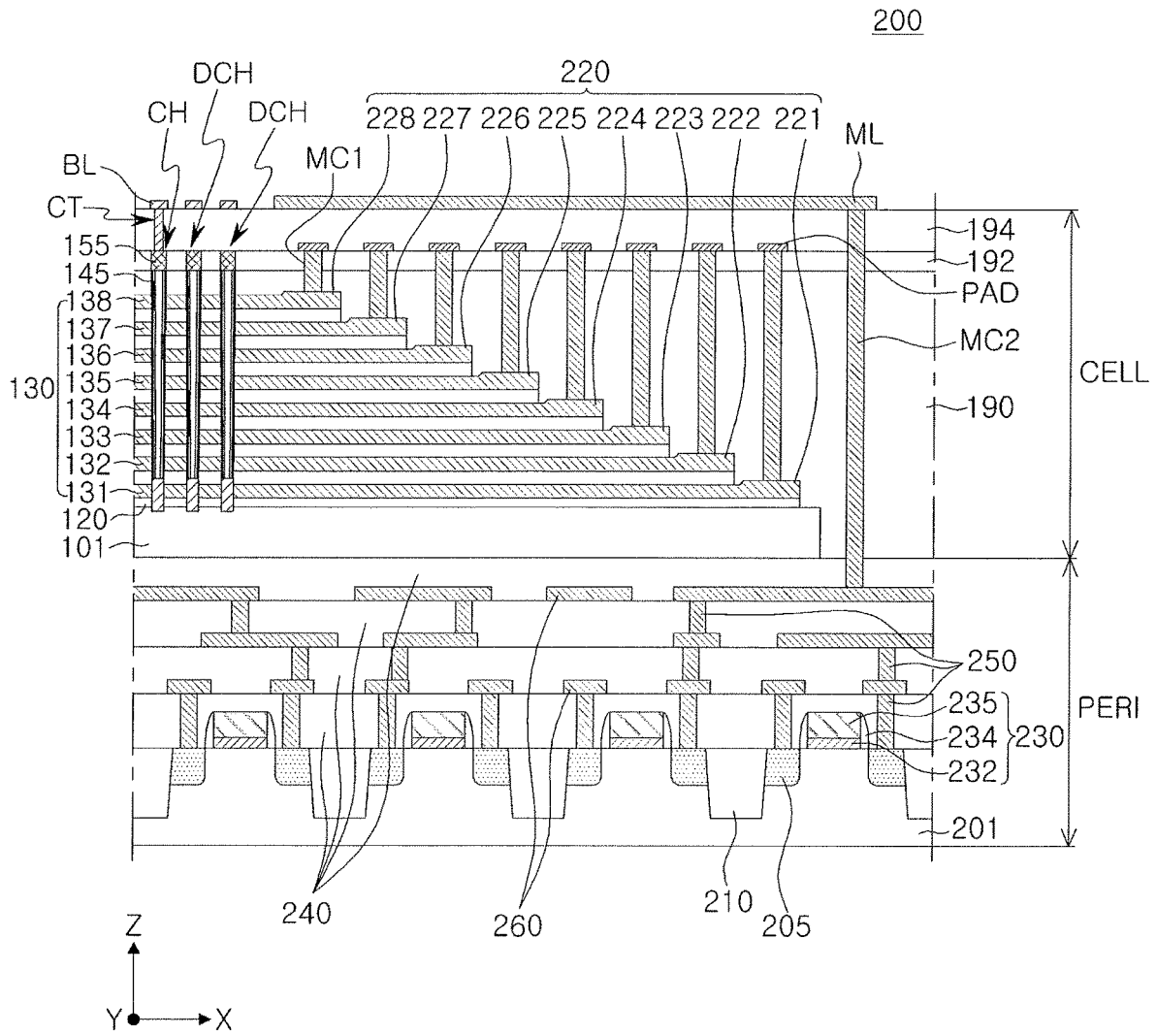

FIG. 19

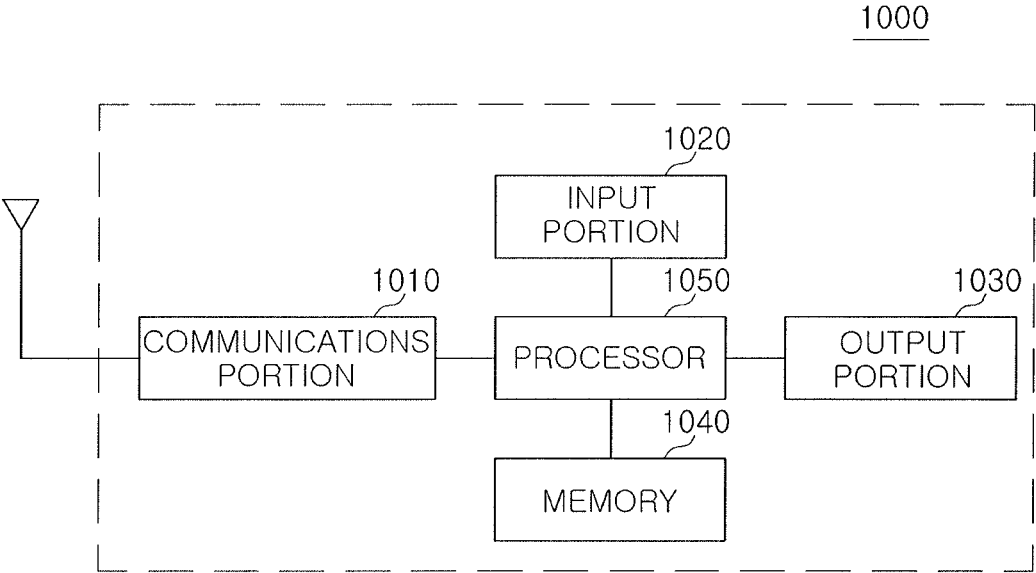

FIG. 20

1

SEMICONDUCTOR DEVICE

CROSS-REFERENCE TO RELATED APPLICATIONS

This is a continuation of U.S. patent application Ser. No. 16/892,384, filed Jun. 4, 2020, which is a continuation of U.S. patent application Ser. No. 15/933,544, filed Mar. 23, 2018, now U.S. Pat. No. 10,680,007 B2, issued Jun. 9, 2020, the entire contents of each is hereby incorporated by reference.

Korean Patent Application No. 10-2017-0090804 filed on Jul. 18, 2017 in the Korean Intellectual Property Office, and entitled: "Semiconductor Device," is incorporated by reference herein in its entirety.

BACKGROUND

1. Field

Embodiments relate to a semiconductor device.

2. Description of the Related Art

Semiconductor devices are required to process large amounts of data while volumes thereof are decreasing. Therefore, it is necessary to increase a degree of integration of the semiconductor elements forming such a semiconductor device. Accordingly, as a method of improving a degree of integration of a semiconductor device, a semiconductor device having a vertical transistor structure, instead of a planar transistor structure, has been proposed.

SUMMARY

According to an aspect of embodiments, a semiconductor device may include gate electrodes stacked along a direction perpendicular to an upper surface of a substrate, the gate electrodes extending to different lengths in a first direction, and each gate electrode including subgate electrodes spaced apart from each other in a second direction perpendicular to the first direction, and gate connection portions connecting subgate electrodes of a same gate electrode of the gate electrodes perpendicularly to the upper surface of the substrate, and dummy channels extending through the gate electrodes perpendicularly to the upper surface of the substrate, the dummy channels including first dummy channels arranged in rows and columns, and second dummy channels arranged between the first dummy channels in a region including the gate connection portions.

According to another aspect of embodiments, a semiconductor device may include gate electrodes including subgate electrodes spaced apart from each other to be perpendicular to an upper surface of a substrate and stacked, and gate connection portions connecting a portion of the subgate electrodes to each other in the same layer, channels extended to be perpendicular to the substrate while passing through the gate electrodes, and dummy channels extended to be perpendicular to the substrate while passing through the gate connection portions or the subgate electrodes near the gate connection portions.

According to yet another aspect of embodiments, a semiconductor device may include a substrate having a first region and a second region, gate electrodes spaced apart from each other in a first direction, perpendicular to an upper surface of the substrate and stacked in the first region, and

2

extended by different lengths in a second direction, perpendicular to the first direction in the second region, first isolation regions extended in the second direction while passing through the gate electrodes, and disposed to be spaced apart from each other in a third direction, perpendicular to the first direction and the second direction, in the first region and the second region, a plurality of second isolation regions passing through the gate electrodes between the first isolation regions, and disposed to be spaced apart from each other in the second direction, channels extended to be perpendicular to the substrate while passing through the gate electrodes in the first region, and dummy channels extended to be perpendicular to the substrate while passing through the gate electrodes, and including first dummy channels arranged in rows and columns and second dummy channels disposed to be adjacent to a region in which the second isolation regions are spaced apart from each other.

BRIEF DESCRIPTION OF DRAWINGS

Features will become apparent to those of skill in the art by describing in detail exemplary embodiments with reference to the attached drawings, in which:

FIG. 1 illustrates a schematic block diagram of a semiconductor device according to example embodiments;

FIG. 2 illustrates an equivalent circuit diagram of a memory cell array of a semiconductor device according to example embodiments;

FIG. 3 illustrates a schematic plan view of a semiconductor device according to example embodiments;

FIGS. 4A through 4D illustrate schematic cross-sectional views of a semiconductor device according to example embodiments;

FIG. 5 illustrates an exploded perspective view of gate electrodes of a semiconductor device according to example embodiments;

FIGS. 6 through 11 illustrate schematic plan views of a semiconductor device according to example embodiments;

FIG. 12 illustrates a perspective view of a portion of a semiconductor device according to example embodiments;

FIGS. 13A-13C, 14A, 14B, 15A, 15B, 16A, 16B, 17A, 17B, 18A, and 18B illustrate schematic plan views and cross-sectional views of stages in a method of manufacturing a semiconductor device according to example embodiments;

FIG. 19 illustrates a schematic cross-sectional view of a semiconductor device according to example embodiments; and

FIG. 20 illustrates a block diagram of an electronic device including a semiconductor device according to example embodiments.

DETAILED DESCRIPTION

Embodiments will now be described in detail with reference to the accompanying drawings.

FIG. 1 is a schematic block diagram of a semiconductor device according to example embodiments.

Referring to FIG. 1, a semiconductor device 10 may include a memory cell array 20 and a control logic 30.

The memory cell array 20 may include a plurality of memory blocks, and each of the memory blocks may include a plurality of memory cells. The plurality of memory cells may be connected to a row decoder 32 through a string select line SSL, a plurality of word lines WLs, and a ground select line GSL, and may be connected to a page buffer 34 through

a plurality of bit lines BLs. In example embodiments, a plurality of memory cells arranged in the same row may be connected to the same word line WL, and a plurality of memory cells arranged in the same column may be connected to the same bit line BL.

The control logic **30** may include the row decoder **32**, the page buffer **34**, and a control circuit **36**.

The row decoder **32** may decode an input address to generate and transmit driving signals of the word line WL. The row decoder **32** may provide a word line voltage generated from a voltage generating circuit in the control circuit **36** to each of a word line WL, having been selected, and word lines WLS, having not been selected, in response to the control of the control circuit **36**.

The page buffer **34** may be connected to the memory cell array **20** through the bit lines BLs to read information stored in the memory cells. The page buffer **34** may temporarily store data to be stored in the memory cells or sense data stored in the memory cells according to an operation mode. The page buffer **34** may include a column decoder and a sense amplifier. The column decoder may selectively activate the bit lines BLs of the memory cell array **20**, and the sense amplifier may sense a voltage of a bit line BL, having been selected by the column decoder, to read data stored in a memory cell, having been selected, during a reading operation.

The control circuit **36** may control operations of the row decoder **32** and the page buffer **34**. The control circuit **36** may receive a control signal and an external voltage transmitted from an external source, and may be operated according to the control signal having been received. The control circuit **36** may include a voltage generating circuit generating a voltage required for internal operations, e.g., a program voltage, a reading voltage, an erasing voltage, or the like, using an external voltage. The control circuit **36** may control reading, writing, and/or erasing operations in response to the control signals. The control circuit **36** may include an input and output circuit. The input and output circuit may receive data DATA to transfer the data to the page buffer **34** in a program operation, and may output the data DATA received from the page buffer **34** in a reading operation.

FIG. 2 is an equivalent circuit diagram of a memory cell array of a semiconductor device according to example embodiments. FIG. 2 is a conceptual circuit diagram illustrating the memory cell array **20** of FIG. 1.

Referring to FIG. 2, the memory cell array **20** may include a plurality of memory cell strings S including memory cells MC connected in series to each other, as well as a ground selection transistor GST and a string select transistor SST connected in series at both ends of the memory cells MC. The memory cells MC, connected in series to each other, may be connected to n number of word lines WL1 to WLn for selection of the memory cells MC, respectively.

A gate terminal of the ground selection transistor GST may be connected to the ground select line GSL, and a source terminal may be connected to the common source line CSL. A gate terminal of the string select transistor SST may be connected to the string select line SSL, and a source terminal may be connected to a drain terminal of the memory cells MC. In FIG. 2, a structure, in which a single ground selection transistor GST and a single string select transistor SST are connected to each of a plurality of memory cells MC, connected in series to each other, is illustrated. Alternatively, a plurality of ground selection transistors GST or a plurality of string select transistors SST may be connected thereto. In example embodiments, one or more dummy lines or buffer lines BUL may be further

disposed between an uppermost word line WLn among the word lines WL1 to WLn and the string select line SSL.

A drain terminal of the string select transistor SST may be connected to the bit line BL. When a signal is applied through the string select line SSL to the gate terminal of the string select transistor SST, a signal, applied through the bit line BL, is transmitted to the memory cells MC, connected in series to each other, so data reading and writing operations may be performed. An erasing voltage is applied through the substrate, so an erasing operation for erasing data written in the memory cells MC may be performed.

A semiconductor element according to an example embodiment may include at least one dummy string DS. The dummy string DS may be a string including a dummy channel electrically isolated from the bit line BL.

FIG. 3 is a schematic plan view of a semiconductor device according to example embodiments. In FIG. 3, only a main configuration of a semiconductor device **100** is illustrated for the sake of understanding. FIGS. 4A through 4D are schematic cross-sectional views of a semiconductor device according to example embodiments. In FIGS. 4A through 4D, cross sections taken along lines A-A', B-B', C-C', and D-D' of FIG. 3, respectively, are illustrated.

Referring to FIGS. 3 through 4D, the semiconductor device **100** may include a substrate **101** having a first region I and a second region II, gate electrodes **130** (e.g., first through eighth gate electrodes **131** to **138**) stacked on the substrate **101**, channels CH and dummy channels DCH disposed to pass through the gate electrodes **130**, a first isolation region MS1 and a second isolation region MS2, extended while passing through the gate electrodes **130**, upper isolation regions SS passing through a portion of the gate electrodes **130**, and a lower isolation region GS passing through one of the gate electrodes **130**. The semiconductor device **100** may further include interlayer insulating layers **120** alternately stacked with the gate electrodes **130** on the substrate **101**, a gate dielectric layer **145**, a channel region **140**, a channel pad **155**, and a channel insulating layer **150** in the channels CH, as well as a peripheral region insulating layer **190**.

The first region I of the substrate **101** may be a region corresponding to the memory cell array **20** of FIG. 1, and the second region II may correspond to a region electrically connecting the memory cell array **20** and the control logic **30** of FIG. 1. The second region II may be disposed in at least one end of the first region I, in at least one direction, e.g., in an x-direction.

The substrate **101** may have an upper surface extended in the x-direction and a y-direction. The substrate **101** may include a semiconductor material, e.g., a Group IV semiconductor, a Group III-V compound semiconductor, or a Group II-VI oxide semiconductor. For example, the Group IV semiconductor may include silicon, germanium or silicon-germanium. The substrate **101** may be provided as a bulk wafer or an epitaxial layer.

The gate electrodes **130** are spaced apart from each other to be perpendicular to the first region I and stacked, e.g., the gate electrodes **130** may be stacked above each other along a direction perpendicular to the top surface of the first region I, and may be extended by different lengths from the first region I to the second region II. Each of the gate electrodes **130** may form a gate of each of the ground selection transistor GST, the plurality of memory cells MC, and the string select transistor SST of FIG. 2. According to the capacity of the semiconductor device **100**, the number of the gate electrodes **130** forming the memory cells MC may be determined. According to example embodiments, a gate

electrode **130** of each of the string select transistor SST and the ground selection transistor GST may be provided as one gate electrode or two or more gate electrodes, and may have a structure the same as or different from the gate electrodes **130** of the memory cells MC. A portion of the gate electrodes **130**, e.g., gate electrodes **130** adjacent to the gate electrodes **130** of the ground selection transistor GST or the string select transistor SST, may be a dummy gate electrode.

As illustrated in FIG. 3, the gate electrodes **130** may be disposed separately from each other in the y-direction by a first isolation region MS1 extended in the x-direction, e.g., a portion of an exposed upper surface of each gate electrode **130** may extend in the y-direction and be at a different height than an upper exposed surface of an adjacent gate electrode **130** (e.g., so FIG. 3 illustrates exposed upper surfaces of each gate electrode between the dummy channels). The gate electrodes **130** between a pair of first isolation regions MS1 may form a single memory block, but a range of a memory block is not limited thereto. A portion among the gate electrodes **130**, e.g., each of first through sixth gate electrodes **131** to **136**, may include gate connection portions GC, and may be connected as a single layer in a single memory block thereby, which will be described in more detail below with reference to FIG. 5. A width W of the gate connection portions GC may be variously changed in example embodiments.

As illustrated in FIG. 4B, the gate electrodes **130** are extended by different lengths in the x-direction in the second region II of the substrate **101** to provide contact regions CP forming a stepped portion in the form of a staircase, e.g., the contact regions CP are in the exposed upper surfaces of the gate electrode **130** discussed previously. In the contact regions CP, the gate electrodes **130** may be connected to contact plugs, and the gate electrodes **130** may be connected to a wiring structure in an upper portion. In the contact regions CP, the gate electrodes **130** may have a form, in which a thickness is increased, so as to be stably connected to contact plugs.

The gate electrodes **130** may include a metal material, e.g., tungsten (W). In example embodiments, the gate electrodes **130** may include a polycrystalline silicon or metal silicide material. In example embodiments, the gate electrodes **130** may further include a diffusion barrier. For example, the diffusion barrier may include tungsten nitride (WN), tantalum nitride (TaN), titanium nitride (TiN), or combinations thereof.

The interlayer insulating layers **120** may be disposed between the gate electrodes **130**. The interlayer insulating layers **120** may be disposed to be extended in the x-direction and to be spaced apart from each other in a direction perpendicular to an upper surface of the substrate **101**, i.e., in a manner similar to the gate electrodes **130**. The interlayer insulating layers **120** may include an insulating material, e.g., silicon oxide or silicon nitride.

The channels CH may be spaced apart from each other in rows and columns in the first region I. The channels CH may be arranged to form a lattice pattern or may be arranged in zigzag form in one direction. The channels CH may have a columnar shape (e.g., CH1 in FIG. 4B) and may have an inclined side surface, e.g., narrower toward the substrate **101** depending on an aspect ratio.

Referring to FIGS. 4A-4B, the channel region **140** may be disposed in the channels CH. The channel region **140** in the channels CH may be formed in an annular shape surrounding a channel insulating layer **150** located therein. However, according to example embodiments, the channel region may have a columnar shape, e.g., a cylinder or a prism, without

the channel insulating layer **150**. The channel region **140** may be connected to an epitaxial layer **105** in a lower portion. The channel region **140** may include a semiconductor material, e.g., polycrystalline silicon or single crystal silicon, and the semiconductor material may be an undoped material, or a material containing p-type or n-type impurities. The channels CH arranged in a straight line in the y-direction may be connected to bit lines BL (see FIGS. 1 and 2) different from each other, respectively, according to arrangement of an upper wiring structure connected to the channel pad **155**.

Channel pads **155** may be disposed in an upper portion of the channel region **140** in the channels CH. The channel pads **155** may be disposed to cover an upper surface of the channel insulating layer **150** and to be electrically connected to the channel region **140**. The channel pads **155** may include, e.g., doped polycrystalline silicon.

The gate dielectric layer **145** may be disposed between the gate electrodes **130** and the channel region **140**. Referring to an enlarged view of FIG. 4A, the gate dielectric layer **145** may include a tunneling layer **142**, a charge storage layer **143**, and a blocking layer **144**, sequentially stacked from the channel region **140**. The tunneling layer **142** may tunnel a charge to the charge storage layer **143** by F-N tunneling mechanism. The tunneling layer **142** may include, e.g., silicon oxide (SiO₂), silicon nitride (Si₃N₄), silicon oxynitride (SiON), or combinations thereof. The charge storage layer **143** may be a charge trapping layer or a floating gate conductive layer. In example embodiments, when the charge storage layer **143** is a charge trapping layer, the charge storage layer **143** may be formed of silicon nitride. The blocking layer **144** may include, e.g., silicon oxide (SiO₂), silicon nitride (Si₃N₄), silicon oxynitride (SiON), a high dielectric constant (high-k) dielectric materials, or combinations thereof. In an example embodiment, the blocking layer **144** may be extended in a horizontal direction along the gate electrodes **130**, but is not limited thereto. For example, at least a portion of the blocking layer **144** may be disposed to be vertically extended along the channel region **140** in the channels CH.

The epitaxial layer **105** may be disposed on the substrate **101** at a lower end of the channels CH, and may be disposed on a side surface of at least one gate electrode **130**. The epitaxial layer **105** may be disposed in a recessed region of the substrate **101**. A level of an upper surface of the epitaxial layer **105** may be higher than a level of an upper surface of the first gate electrode **131** located in a lowermost portion, and may be lower than a level of a lower surface of an upper gate electrode **132**, but an example embodiment is not limited thereto. Even when an aspect ratio of the channel region **140** is increased, the channel region **140** may be stably electrically connected to the substrate **101** by the epitaxial layer **105**, and characteristics of the ground selection transistor GST between memory cell strings may be uniform. However, in example embodiments, the epitaxial layer **105** may be omitted. In this case, the channel region **140** may be directly connected to the substrate **101**.

The dummy channels DCH may be disposed in both the first region I and the second region II. The dummy channels DCH may have the same structure as that of the channels CH, but may not perform a substantial function in the semiconductor device **100**. The dummy channels DCH may form the dummy string DS described above with reference to FIG. 2. In FIG. 3, the dummy channels DCH are illustrated as having the same size and shape as those of the channels CH, but an example embodiment is not limited thereto. In example embodiments, the dummy channels may

have a larger size than that of the channels CH, or may have an elliptical shape. The dummy channels DCH may include first dummy channels DCH1 arranged in rows and columns at an end of the gate electrodes 130, second dummy channels DCH2 disposed in a region including the gate connection portion GC between second isolation regions MS2, and third dummy channels DCH3 arranged in the same rule, e.g., pattern, as the channels CH while being adjacent to the channels CH in the first region I, e.g., the third dummy channels DCH3 may be arranged between the first dummy channels DCH1 and the channels CH. A portion of the dummy channels DCH may be included between, e.g., among, the channels CH. For example, channels CH formed to overlap with an upper isolation region SS are not indicated separately, but may correspond to a dummy channel.

Each of the first dummy channel DCH1 and the third dummy channel DCH3 may be arranged in a predetermined manner. The second dummy channels DCH2 may be disposed in a local region including the gate connection portion GC, and may be disposed differently from an arrangement manner of the first dummy channel DCH1 and the third dummy channel DCH3. Thus, due to the second dummy channels DCH2, in the periphery of the gate connection portion GC, a density of the dummy channels DCH may be increased and a pitch may be reduced. The second dummy channels DCH2 may be disposed to be closest to the gate connection portion GC among the dummy channels DCH. Thus, a distance between the gate connection portion GC and the second dummy channel DCH2 adjacent thereto may be smaller than a distance between the gate connection portion GC and the first dummy channel DCH1 adjacent thereto. A portion of the second dummy channels DCH2 may be disposed between the second isolation regions MS2 to pass through the gate connection portion GC, and a portion thereamong may be disposed to be spaced apart from the gate connection portion GC in the y-direction.

At least a portion of the second dummy channels DCH2 may be disposed between the first dummy channels DCH1 adjacent thereto. In detail, the first dummy channels DCH1 may be disposed to be spaced apart from each other by a first separation distance D1 in the x-direction, e.g., the first dummy channels DCH1 may be arranged in columns along the y-direction that are spaced apart from each other along the x-direction by the first separation distance D1. A separation distance D2 along the x-direction between the second dummy channel DCH2 and the first dummy channel DCH1 may be smaller than the first separation distance D1. For example, as illustrated in FIG. 3, the first and second separation distances D1 and D2 may be measured between parallel tangent lines corresponding to facing sidewalls of adjacent dummy channels. For example, as further illustrated in FIG. 3, the second dummy channels DCH2 may be arranged in a column along the y-direction that extends in parallel to and between two adjacent columns of the first dummy channels DCH1, e.g., a distance between adjacent ones of the second dummy channels DCH2 along the y-direction may be different than a distance between adjacent ones of the first dummy channels DCH1 along the y-direction.

A region in which the gate connection portion GC is disposed may be vulnerable to collapsing during a process of manufacturing the semiconductor device 100, e.g., during removal of sacrificial layers during manufacturing. However, the second dummy channels DCH2 passing through the gate electrodes 130 to be extended from the substrate 101

are disposed in a local region including the gate connection portion GC, thereby performing a supporting role and thus preventing collapsing.

The first isolation region MS1 and the second isolation region MS2 may be disposed to be extended in the x-direction in the first region I and the second region II. The first isolation regions MS1 and the second isolation regions MS2 may be alternately disposed in the y-direction, and the second isolation regions MS2 may be disposed to be spaced apart from each other in a straight line in the x-direction. That is, as illustrated in FIG. 3, the first isolation regions MS1 may extend in the x-direction and be spaced apart from each other in the y-direction, and the second isolation regions MS2 may extend in the x-direction and be spaced apart from each other in the x-direction, e.g., the second isolation regions MS2 may extend in parallel to and between two adjacent first isolation regions MS1. The first isolation region MS1 and the second isolation region MS2 may pass through the entirety of the gate electrodes 130 stacked on the substrate 101 to be connected to the substrate 101. A placement order of the first isolation regions MS1 and the second isolation regions MS2 is not limited to that illustrated in FIG. 3. For example, in example embodiments, the second isolation regions MS2 may be arranged in two or more rows between the first isolation regions MS1 in the y-direction.

The first isolation regions MS1 may include the common source line CSL illustrated with reference to FIG. 2, and the second isolation regions MS2 may include a dummy common source line. As illustrated in FIGS. 4A and 4D, the first isolation region MS1 and the second isolation region MS2 may include an insulating layer 107 and a conductive layer 110 insulated from the gate electrodes 130 by the insulating layer 107. A conductive layer 110 of the first isolation regions MS1 may correspond to the common source line CSL, and the conductive layer 110 of the second isolation regions MS2 may correspond to a dummy common source line. Thus, the conductive layer 110 forming the second isolation regions MS2 may be in a floating state, i.e., a state of non-connection to elements for driving the semiconductor device 100 or a state in which an electrical signal is not applied, in a manner different from the conductive layer 110 in the first isolation regions MS1 corresponding to the common source line CSL.

The upper isolation regions SS may be extended in the x-direction between the first isolation regions MS1 and the second isolation region MS2. The upper isolation regions SS may be disposed in a portion of the second region II and the first region I, in order to pass through a portion of the gate electrodes 130 including an eighth gate electrode 138 located in an uppermost portion among the gate electrodes 130. The gate electrodes 130 separated by the upper isolation regions SS may form different string selection lines SSL (see FIG. 2). The upper isolation regions SS may include the upper insulating layer 103. As illustrated in FIG. 4D, the upper isolation regions SS may extend to a predetermined depth with the upper insulating layer 103 therein, so the upper insulating layer 103 may allow a total of three gate electrodes 130, including the eighth gate electrode 138 located in an uppermost portion, to be separated from each other in the y-direction. However, the number of the gate electrodes 130 separated by the upper insulating layer 103 is not limited thereto.

The lower isolation region GS may be disposed in a region including the gate connection portion GC on a plane, and may be disposed on the same level as that of the first gate electrode 131 (FIGS. 4A and 4C). In detail, as illus-

trated in FIG. 4C, the first gate electrode **131** may be divided in the y-direction in a lower portion of the gate connection portion GC by the lower isolation region GS. The lower isolation region GS may include a lower insulating layer **170**. As illustrated in FIG. 4C, the lower isolation region GS may be disposed to allow the first gate electrode **131** to be separated in the y-direction in the lower portion of the gate connection portion GC.

FIG. 5 is an exploded perspective view illustrating the gate electrodes **130** of the semiconductor device **100** according to example embodiments. In detail, FIG. 5 illustrates a portion among the gate electrodes **130** disposed between the first isolation regions MS1 of FIG. 3.

Referring to FIG. 5, a seventh gate electrode **137** and an eighth gate electrode **138** among the gate electrodes **130**, located in an uppermost portion, may be used as the string select line SSL, and each of the seventh gate electrode **137** and the eighth gate electrode **138** may be divided into four subgate electrodes (e.g., first through fourth subgate electrodes **137a1**, **137a2**, **137b1**, and **137b2**, and first through fourth subgate electrodes **138a1**, **138a2**, **138b1**, and **138b2**) in the y-direction by the upper isolation regions SS and the second isolation regions MS2. Each of the subgate electrodes **137a1** to **137b2** and **138a1** to **138b2** may be connected to different contact plugs to receive electrical signals independently, e.g., the subgate electrodes **137a1** to **137b2** and **138a1** to **138b2** may be electrically completely separated from each other.

In a fifth gate electrode **135** and a sixth gate electrode **136** below the seventh gate electrode **137** and the eighth gate electrode **138**, subgate electrodes **135a**, **135b**, **136a**, and **136b**, having the second isolation regions MS2 as a boundary, are not separated from each other, and may be connected to each other as a single layer. In detail, the subgate electrodes **135a**, **135b**, **136a**, and **136b** may be connected to each other by the gate connection portions GC, and thus may be disposed as a single fifth gate electrode **135** and a single sixth gate electrode **136**.

For example, as illustrated in FIG. 5, the gate connection portion GC may be a portion extending integrally with each of the subgate electrodes, e.g., of a same material and same thickness to connect seamlessly the subgate electrodes to each other. For example, as illustrated in FIG. 5, the gate connection portion GC in the fifth gate electrode **135** extends integrally with each of the subgate electrodes **135a** and **135b** (e.g., of a same material and same thickness as the subgate electrodes **135a** and **135b**), and between the two adjacent second isolation regions MS2. For example, as illustrated in FIG. 5, the gate connection portion GC of the fifth gate electrode **135** may be the entire solid portion between the two adjacent second isolation regions MS2 in the x-direction and between the subgate electrodes **135a** and **135b** in the y-direction (framed by the dashed frame), so that the gate connection portion GC of the fifth gate electrode **135** may include a single second dummy channel there-through, and two second dummy channels adjacent to the gate connection portion GC, e.g., the adjacent two second dummy channels may be formed through the subgate electrodes **135a** and **135b**, respectively.

The second gate electrode **132**, the third gate electrode **133**, and the fourth gate electrode **134**, not illustrated in FIG. 5, may have a form connected by the gate connection portions GC in a similar manner to the fifth gate electrode **135** and the sixth gate electrode **136**. Thus, the gate connection portions GC may allow gate electrodes **130**, located below the sixth gate electrode **136**, to be connected as one between the first isolation regions MS1, so the number of

contact plugs connected thereto may be significantly reduced. Thus, a wiring structure connected to the gate electrodes **130** may be simplified.

As further illustrated in FIG. 5, the first gate electrode **131** located in a lowermost portion among the gate electrodes **130** may be used as the ground select line GSL, and may be divided into subgate electrodes **131a** and **131b** by the lower isolation region GS and the second isolation regions MS2. The lower isolation region GS is disposed to include a region between the second isolation regions MS2, so the first gate electrode **131** may be divided by a combination of the lower isolation region GS and the second isolation regions MS2. Each of the subgate electrodes **131a** and **131b** may have a bent portion or curvature in surfaces opposing each other. The bent portion may be provided by a difference in width between the lower isolation region GS and the second isolation regions MS2 in the y-direction. However, a relative size of a width of the lower isolation region GS and a width of the second isolation regions MS2 is not limited thereto, and may be variously changed in example embodiments.

FIGS. 6 through 11 are schematic plan views of a semiconductor device according to example embodiments.

Referring to FIG. 6, in a semiconductor device **100a**, in a manner different from the example embodiment of FIG. 3, the number of second dummy channels DCH2a disposed to pass through a gate connection portion GCa between the second isolation regions MS2 may be two or more, e.g., three. The number of the second dummy channels DCH2a disposed to be adjacent to the gate connection portion GCa may be four or more, e.g., six, and may be disposed between the first dummy channels DCH1. In example embodiments, the second dummy channels DCH2a may be disposed in a row in the y-direction, as illustrated in the drawing, or may be shifted and arranged in zigzag form.

In an example embodiment, a gap between the second isolation regions MS2 is greater, compared to the example embodiment of FIG. 3, so a length D3 in the x-direction of the gate connection portion GCa and a length in the x-direction of a lower isolation region GSa may be relatively great. In example embodiments, the length D3 in the x-direction of the gate connection portion GCa may be variously changed. Thus, the number of the second dummy channels DCH2a, passing through the gate connection portion GCa or disposed to be adjacent to the gate connection portion GCa, may be variously changed.

Referring to FIG. 7, a semiconductor device **100b**, in a manner different from the example embodiment of FIG. 3, may not include a second dummy channel DCH2b disposed to pass through the gate connection portion GC between the second isolation regions MS2. Thus, the second dummy channel DCH2b may not pass through the gate connection portion GC itself, but may be disposed only in a region adjacent thereto. The arrangement described above may be applied to, e.g., a case in which a gap between the second isolation regions MS2 is narrow, but an example embodiment is not limited thereto.

Referring to FIG. 8, a semiconductor device **100c**, in a manner different from the example embodiment of FIG. 3, may include three or more second isolation regions MS2a disposed in a straight line in the x-direction, and thus may include two or more gate connection portions GC. The gate connection portions GC in an example embodiment may be disposed in a second region II. The number of the gate connection portions GC may be variously selected in consideration of a length of the second region II, an aspect ratio of a stacked structure of the gate electrodes **130**, a process, and the like, in example embodiments.

11

Referring to FIG. 9, a semiconductor device **100d**, in a manner different from the example embodiment of FIG. 3, may include four or more second isolation regions **MS2a** disposed in a straight line in the x-direction, and thus may include three or more gate connection portions **GC**. In an example embodiment, in a manner different from the example embodiment of FIG. 8, the gate connection portions **GC** may not only be disposed in the second region II but also in the first region I. In an example embodiment, one of the gate connection portions **GC** is disposed to be adjacent to a portion of the first region I, in which the third dummy channels **DCH3** are disposed, but an example embodiment is not limited thereto. In example embodiments, the gate connection portion **GC** may be disposed to be adjacent to a region in which the channels **CH** are disposed. When the gate connection portions **GC** are disposed in the first region I, or may be disposed in a portion in the second region II, close to the first region I, an auxiliary upper isolation region **SSa** passing through a portion of the gate electrodes **130** may be further disposed between the second isolation regions **MS2a**. In other words, when the gate connection portions **GC** are disposed to be closer to the first region I than one end of a seventh gate electrode **137** divided by an upper isolation region **SS**, even in the second region II, in order to allow the seventh gate electrode **137** and the eighth gate electrode **138** not to be connected to each other by the gate connection portions **GC**, the auxiliary upper isolation region **SSa** may be disposed in parallel with the upper isolation region **SS**.

In addition, in an example embodiment, in a manner different from the example embodiments of FIGS. 3 and 8, a second dummy channel **DCH2c** is disposed to pass through the gate connection portion **GC** between the second isolation regions **MS2a**, and may not be disposed in a region between the first dummy channels **DCH1** adjacent to the gate connection portion **GC**. However, in example embodiments, in the gate connection portions **GC**, the arrangement of the second dummy channel **DCH2c** in a periphery of the gate connection portions **GC** may be different from each other. For example, the second dummy channel **DCH2c** may not be disposed in a periphery of the gate connection portion **GC** of the first region I, and the second dummy channels **DCH2c** may be disposed in a periphery of the gate connection portion **GC** of the second region II as illustrated in FIG. 3.

Referring to FIGS. 10 and 11, semiconductor devices **100e** and **100f** may further include contact plugs **MC** disposed in a stepped region of the gate electrodes **130**, i.e., in the contact regions **CP**. The contact plugs **MC** may allow each of the gate electrodes **130** to be connected to an upper wiring structure, and may be formed of a conductive material.

As illustrated in FIG. 10, in a contact region **CP** in which the gate connection portion **GC** is exposed, i.e., in the contact region **CP** including the gate connection portion **GC**, at least a portion of the contact plugs **MC** may be omitted. For example, while the contact plugs **MC** are regularly arranged in the contact regions **CP** not including the gate connection portion **GC**, some of the contact plugs **MC** may be omitted from the exposed upper surface of the sixth gate electrode **136** in a periphery of the second dummy channel **DCH2**. Even in this case, the sixth gate electrode **136** is connected as one by the gate connection portion **GC**, and thus may be connected to the wiring structure through the remaining contact plugs **MC**, e.g., at edges of the exposed upper surface of the sixth gate electrode **136**.

As illustrated in FIG. 11, a portion among the gate electrodes **130**, a first gate electrode **131**, a second gate

12

electrode **132**, and a third gate electrode **133**, are disposed to have a stepped portion not only in the x-direction but also in the y-direction, so respective contact regions **CP** are formed. Thus, each of the first gate electrode **131**, the second gate electrode **132**, and the third gate electrode **133** may be formed of four gate electrodes **130**. Such a structure will be described in more detail in FIG. 12.

At least one contact plug **MC** is required to be disposed in each of the contact regions **CP**, so the contact plugs **MC** may be disposed to be shifted in the y-direction in the contact regions **CP** of the third gate electrode **133** including the gate connection portion **GC**. In other words, in the contact regions **CP** of the third gate electrode **133** adjacent to the gate connection portion **GC**, the contact plug **MC** may be disposed to be shifted to be away from the gate connection portion **GC** by a distance **D4** in the y-direction, as compared to the contact plugs **MC** of different gate electrodes **130**. Thus, a distance **D5** between the contact plug **MC** and a second dummy channel **DCH2** adjacent thereto may be secured. For example, the distance **D5** may be about 50 nm or more, e.g., about 50 nm to about 200 nm.

FIG. 12 is a perspective view illustrating a portion of a configuration of a semiconductor device according to example embodiments.

Referring to FIG. 12, a stacked structure of the gate electrodes **130**, the interlayer insulating layers **120**, the second dummy channels **DCH2**, and the contact plugs **MC** disposed to pass through the stacked structure are illustrated. The stacked structure is a portion corresponding to a region between the first isolation regions **MS1** of FIG. 3, and the gate electrodes **130** may be disposed in a similar manner to the semiconductor device **100** described above with reference to FIGS. 3 through 4D. A portion of the gate electrodes **130** may be separated by the second isolation regions **MS2** between the first isolation regions **MS1**, and a portion of the gate electrodes **130** may be connected as a single layer by the gate connection portion **GC**. The gate connection portion **GC** may be formed to be relatively narrow, and thus may be vulnerable to safety during a process, but the second dummy channels **DCH2** may perform a supporting role. In example embodiments, depending on the number of the gate electrodes **130**, a region having a structure corresponding to a unit stacked structure **SU** may be added.

In a manner different from that of the example embodiment of FIG. 3, in the gate electrodes **130** according to an example embodiment, a portion of the gate electrodes **130** is formed to have a stepped portion not only in the x-direction but also in the y-direction, thereby forming respective contact regions **CP**. Thus, at least one among the contact plugs **MC** formed in a gate electrode **130** connected as a single layer may be connected to an upper wiring structure. In an example embodiment, a portion of the gate electrodes **130** may be connected as a single layer by the gate connection portion **GC**. Thus, even when contact regions **CP** having a stepped portion in the y-direction is formed, the entirety of one gate electrode **130** may be electrically connected to an upper wiring structure by at least one contact plug **MC**. Thus, compared to a case without the gate connection portion **GC**, the number of contact plugs **MC** required to be connected to the wiring structure may be reduced, so a wiring structure may be further simplified.

FIGS. 13A through 18B are schematic plan views and cross-sectional views illustrating stages in a method of manufacturing a semiconductor device according to example embodiments.

Referring to FIGS. 13A through 13C, the lower isolation region **GS**, sacrificial layers **180** (e.g., sacrificial layers **181**

to 188), and the interlayer insulating layers 120 are alternately stacked on the substrate 101, and a portion of the sacrificial layers 180 and the interlayer insulating layers 120 may be removed in order to allow the sacrificial layers 180 to be extended by different lengths in the x-direction.

In detail, after a first sacrificial layer 181 located in a lowermost portion is formed, e.g., on a first interlayer insulating layer 120, a patterning process and a deposition process of an insulating material are performed. For example, a portion of the first sacrificial layer 181 may be removed, and an insulating material may be deposited to replace the removed portion of the first sacrificial layer 181. Thus, as illustrated in FIG. 13C, the lower isolation region GS including the lower insulating layer 170 may be formed. The lower insulating layer 170 may be formed of a material having an etch selectivity with respect to the sacrificial layers 180, and may be formed of, e.g., the same material as the interlayer insulating layer 120.

The sacrificial layers 180 may be layers to be replaced with the gate electrodes 130 in a subsequent process. The sacrificial layers 180 may be formed of a material to be etched with an etch selectivity with respect to the interlayer insulating layers 120. For example, the interlayer insulating layer 120 may be formed of at least one of silicon oxide and silicon nitride, and the sacrificial layers 180 may be formed of a different material from the interlayer insulating layer 120, e.g., of silicon, silicon oxide, silicon carbide, and silicon nitride. In example embodiments, thicknesses of the interlayer insulating layers 120 may not be uniform. For example, an interlayer insulating layer 120 located in a lowermost portion may be formed to be relatively thin, and an interlayer insulating layer 120 located in an uppermost portion may be formed to be relatively thick. Thicknesses of the interlayer insulating layers 120 and the sacrificial layers 180 and the number of films forming the same may be variously changed from those illustrated.

In order to allow sacrificial layers 180 located in an upper portion to be extended by a distance shorter than sacrificial layers 180 located in a lower portion in the second region II (along the x-direction), a photolithography process and an etching process for the sacrificial layers 180 may be repeatedly performed. The sacrificial layers 180 may be formed in a stepped shape thereby. Next, a material forming the sacrificial layers 180 is additionally disposed in regions, which are exposed as sacrificial layers 180 are extended further than the sacrificial layers 180 located in an upper portion, so the sacrificial layers 180 may be formed to be relatively thick at an end portion. Next, the peripheral region insulating layer 190 covering an upper portion of a stacked structure of the sacrificial layers 180 and the interlayer insulating layers 120 may be formed.

Referring to FIGS. 14A and 14B, the upper isolation region SS including the upper insulating layer 103 may be formed by removing a portion of the sacrificial layers 180 and the interlayer insulating layers 120.

The upper isolation region SS may be extended in the x-direction from the first region I to a portion of the second region II, and may extend to a predetermined depth in the z-direction. A separate mask layer is used to expose a region in which the upper isolation region SS is to be formed, and the predetermined number of the sacrificial layers 180 and the interlayer insulating layers 120 may be removed from the top. An insulating material is deposited in a region from which the sacrificial layers 180 and the interlayer insulating layers 120 are removed, so the upper insulating layer 103 may be formed. The upper insulating layer 103 may be formed of a material having an etch selectivity with respect

to the sacrificial layers 180, and may be formed of, e.g., the same material as the interlayer insulating layer 120.

Referring to FIGS. 15A and 15B, the channels CH and the dummy channels DCH passing through the stacked structure of the sacrificial layers 180 and the interlayer insulating layers 120 may be formed. The channels CH and the dummy channels DCH may be formed by anisotropically etching the sacrificial layers 180 and the interlayer insulating layers 120, and may be provided in a hole shape.

Due to a height of the stacked structure, a side wall of the channels CH and the dummy channels DCH may not be perpendicular to an upper surface of the substrate 101. In example embodiments, the channels CH and the dummy channels DCH may be formed to recess a portion of the substrate 101. Next, in the channels CH and the dummy channels DCH, the epitaxial layer 105, at least a portion of the gate dielectric layer 145, the channel region 140, the channel insulating layer 150, and the channel pads 155 may be formed. The channels CH and the dummy channels DCH may have the same size, shape, and structure, but an example embodiment is not limited thereto. The first dummy channels DCH1 among the dummy channels DCH may be disposed in an outer side of the channels CH, the second dummy channels DCH2 may be disposed in a boundary of an end of the gate electrodes 130, and the third dummy channels DCH3 may be disposed in a region including the lower isolation region GS.

The epitaxial layer 105 may be formed using a selective epitaxial growth (SEG) process. The epitaxial layer 105 may be formed of a single layer or a plurality of layers. The epitaxial layer 105 may include impurity doped or undoped polycrystalline silicon, single crystalline silicon, polycrystalline germanium, or single crystalline germanium.

The gate dielectric layer 145 may be formed to have a uniform thickness using an atomic layer deposition (ALD) or chemical vapor deposition (CVD) process. An entirety or a portion of the gate dielectric layer 145 may be formed in an operation described above, and a portion extended to be perpendicular to the substrate 101 along the channels CH, e.g., the tunneling layer 142 and the charge storage layer 143 of FIG. 4A, may be formed in the operation described above. The channel region 140 may be formed on the gate dielectric layer 145 in the channels CH. The channel insulating layer 150 is formed to fill the channels CH, and may be an insulating material. However, according to example embodiments, a gap between channel regions 140 may be filled with a conductive material rather than the channel insulating layer 150. The channel pad 155 may be formed of a conductive material, and may be formed of, e.g., polycrystalline silicon.

Referring to FIGS. 16A and 16B, a first opening OP1 and a second opening OP2, passing through the stacked structure of the sacrificial layers 180 and the interlayer insulating layers 120 are formed, and the sacrificial layers 180, having been exposed therethrough, may be removed.

The first opening OP1 and the second opening OP2 may be formed by forming a mask layer using a photolithography process, and anisotropically etching the stacked structure. The first opening OP1 and the second opening OP2 may be formed in a trench shape extended in the x-direction. In an operation described above, the substrate 101 may be exposed below the first opening OP1 and the second opening OP2.

The sacrificial layers 180 may be selectively removed with respect to the interlayer insulating layers 120, using, e.g., wet etching. Thus, a plurality of side openings may be formed between the interlayer insulating layers 120, and a

portion of side walls of the gate dielectric layer **145** in the channels CH and the dummy channels DCH and a side wall of the lower insulating layer **170** may be exposed through the side openings. In an operation described above, after the sacrificial layers **180** are removed, stability of a stacked structure of the interlayer insulating layer **120** may be reduced. In detail, a region between the second openings OP2 may be vulnerable to collapsing. However, as the second dummy channels DCH2 are disposed, the stacked structure of the interlayer insulating layer **120** may be more stably supported in the region between the second openings OP2.

Referring to FIGS. **17A** and **17B**, a conductive material is filled in a region from which the sacrificial layers **180** are removed to form the gate electrodes **130**, and the insulating layer **107** may be formed in the first opening OP1 and the second opening OP2. The gate electrodes **130** may include, e.g., metal, polycrystalline silicon, or a metal silicide material.

The second openings OP2 may provide a transfer path of a material for formation of the gate electrodes **130** together with the first openings OP1. Even when a separation distance of the first openings OP1 in the y-direction is relatively large, filling of the gate electrodes **130** may be effectively performed due to the presence of the second openings OP2. After the gate electrodes **130** are formed, a material forming the gate electrodes **130** deposited in the first opening OP1 and the second opening OP2 may be removed through an additional process.

Next, the insulating layer **107** may be formed in the first opening OP1 and the second opening OP2. The insulating layer **107** may be provided in the form of a spacer in the first opening OP1 and the second opening OP2. In other words, after an insulating material is deposited, an insulating material formed on the substrate **101** is removed from a lower portion of the first opening OP1 and the second opening OP2, so the insulating layer **107** may be formed.

Next, as illustrated in FIGS. **4C** and **4D**, a conductive material is deposited on the insulating layer **107**, so the conductive layer **110** may be formed. Thus, the first isolation region MS1 and the second isolation region MS2 may be formed thereby.

Referring to FIGS. **18A** and **18B**, a wiring insulation layer **192** is formed on the peripheral region insulating layer **190**, and channel plugs CT passing through the wiring insulation layer **192** to be connected to the channel pad **155**, and bit lines BL and dummy bit lines DBL may be formed.

The channel plugs CT may be formed above the channels CH, and may be not formed above the dummy channels DCH. The channels CH may be connected to bit lines BL in an upper portion through the channel plugs CT. The dummy channels DCH may not be connected to dummy bit lines DBL in an upper portion. Alternatively, in example embodiments, the dummy channels DCH may be connected to dummy bit lines DBL in an upper portion by separate plugs, and the dummy bit lines DBL may be in a floating state.

The bit lines BL and the dummy bit lines DBL, as illustrated in FIG. **18A**, may be disposed to allow two channels CH and two first dummy channels DHC1, adjacent in the y-direction, to be connected to each other. In detail, channels CH disposed between a single first isolation region MS1 and an upper isolation region SS may be connected to different bit lines BL, respectively. However, the arrangement of the bit lines BL and the dummy bit lines DBL is not limited to those illustrated, and may be variously changed. The channel plugs CT and the bit lines BL may be formed of a conductive material.

FIG. **19** is a schematic cross-sectional view of a semiconductor device according to example embodiments.

Referring to FIG. **19**, a semiconductor device **200** may include a memory cell region CELL and a peripheral circuit region PERI. The memory cell region CELL may be disposed in an upper end of the peripheral circuit region PERI. In example embodiments, the memory cell region CELL may be disposed at a lower end of the peripheral circuit region PERI.

The memory cell region CELL, as illustrated previously with reference to FIGS. **3** through **4D**, may include a substrate **101**, gate electrodes **130** stacked on the substrate **101**, and channels CH and dummy channels DCH, disposed to pass through the gate electrodes **130**. The memory cell region CELL may further include a peripheral region insulating layer **190** and wiring insulation layers **192** and **194**, and may further include channel plugs CT and bit lines BL connected to channel pads **155**, pads PAD connected to first contact plugs MC1, and a metal line ML. The memory cell region CELL may have a structure according to various example embodiments as described previously with reference to FIGS. **3** through **12**.

The peripheral circuit region PERI may include a base substrate **201**, circuit elements **230** disposed on the base substrate **201**, circuit contact plugs **250**, and wiring lines **260**.

The base substrate **201** may have an upper surface extended in the x-direction and in the y-direction. In the base substrate **201**, element isolation layers **210** are formed therein, so an active region may be defined. Source/drain regions **205** including impurities may be disposed in a portion of the active region. The base substrate **201** may include a semiconductor material, e.g., a Group IV semiconductor, a Group III-V compound semiconductor, or a Group II-VI oxide semiconductor.

The circuit elements **230** may include a horizontal transistor. Each of the circuit elements **230** may include a circuit gate insulating layer **232**, a spacer layer **234**, and a circuit gate electrode **235**. The source/drain regions **205** may be disposed in the base substrate **201** on both sides of the circuit gate electrode **235**.

A plurality of peripheral region insulating layers **240** may be disposed in a circuit element **230** above the base substrate **201**. The circuit contact plugs **250** may pass through the peripheral region insulating layers **240** to be connected to the source/drain regions **205**. An electrical signal may be applied to the circuit element **230** by the circuit contact plugs **250**. In a region not illustrated, the circuit contact plugs **250** may also be connected to the circuit gate electrode **235**. The wiring lines **260** may be connected to the circuit contact plugs **250**, and may be disposed as a plurality of layers. The gate electrodes **130** of the memory cell region CELL may be connected to the circuit elements **230** of the peripheral circuit region PERI through the metal line ML and the second contact plug MC2.

In the semiconductor device **200**, after the peripheral circuit region PERI is manufactured first, the substrate **101** of the memory cell region CELL is formed in an upper portion thereof, so the memory cell region CELL may be manufactured. The substrate **101** may have the same size as the base substrate **201**, or may be formed to be smaller than the base substrate **201**.

FIG. **20** is a block diagram illustrating an electronic device including a semiconductor device according to example embodiments.

Referring to FIG. **20**, an electronic device **1000** according to an example embodiment may include a communications

17

portion **1010**, an input portion **1020**, an output portion **1030**, a memory **1040**, and a processor **1050**.

The communications portion **1010** may include a wired/wireless communications module, and may include a wireless Internet module, a local communications module, a GPS module, a mobile communications module, and the like. The wired/wireless communications module included in the communications portion **1010** is connected to an external communications network by various communications standard specifications to transmit and receive data. The input portion **1020** is a module provided to allow an operation of the electronic device **1000** to be controlled by a user, may include a mechanical switch, a touch screen, a voice recognition module, and the like, and may further include various sensor modules through which a user can input data. The output portion **1030** may output information processed in the electronic device **1000** in the form of audio or image data, and the memory **1040** may store a program for processing and controlling the processor **1050**, data, or the like. The memory **1040** may include one or more semiconductor devices according to various example embodiments as described previously with reference to FIGS. 3 through 19, and may communicate with the processor **1050** either embedded in the electronic device **1000** or via a separate interface. The processor **1050** may control an operation of each portion included in the electronic device **1000**. The processor **1050** may perform controlling and processing related to voice communication, video communication, data communication, and the like, or may perform controlling and processing for multimedia playback and management. The processor **1050** may process input received from a user through the input portion **1020** and may output the result through the output portion **1030**, and may store data, necessary for controlling an operation of the electronic device **1000**, in the memory **1040** or may retrieve the data from the memory **1040**.

By way of summation and review, according to example embodiments, dummy channels are disposed in a periphery of a gate connection portion, so a semiconductor device having improved reliability may be provided. That is, dummy channels are disposed in an interior of or along, e.g., directly adjacent to, a side surface of the gate connection portion, e.g., an H-cut structure, to prevent collapsing of the gate connection portion during manufacturing.

Example embodiments have been disclosed herein, and although specific terms are employed, they are used and are to be interpreted in a generic and descriptive sense only and not for purpose of limitation. In some instances, as would be apparent to one of ordinary skill in the art as of the filing of the present application, features, characteristics, and/or elements described in connection with a particular embodiment may be used singly or in combination with features, characteristics, and/or elements described in connection with other embodiments unless otherwise specifically indicated. Accordingly, it will be understood by those of skill in the art that various changes in form and details may be made without departing from the spirit and scope of the present invention as set forth in the following claims.

What is claimed is:

1. A semiconductor device, comprising:

a substrate having a first region and a second region; gate electrodes stacked perpendicularly on an upper surface of the substrate in the first region, the gate electrodes extending to different lengths in a first direction in the second region, and each of the gate electrodes including:

18

subgate electrodes spaced apart from each other in a second direction perpendicular to the first direction, and

a gate connection portion connecting to each other subgate electrodes at a same level;

channels extending through the gate electrodes perpendicularly to the upper surface of the substrate in the first region; and

dummy channels extending through the gate electrodes perpendicularly to the upper surface of the substrate, the dummy channels including:

first dummy channels arranged in the second region in rows and columns, the rows extending in the first direction, and the columns extending in the second direction, and

a second dummy channel passing through the gate connection portion in the second region, the second dummy channel being arranged between two columns of the first dummy channels that are adjacent to each other along the first direction,

wherein the first region is a memory cell region including a plurality of memory cells along the channels, and the second region electrically connects the memory cell region and a control logic region driving the plurality of memory cells.

2. The semiconductor device as claimed in claim 1, further comprising a lower isolation region passing through at least one of gate electrode in a lowermost portion among the gate electrodes, the gate connection portion overlapping the lower isolation region, in a plan-view.

3. The semiconductor device as claimed in claim 1, further comprising:

a wiring insulation layer on the channels and the dummy channels;

channel plugs passing through the wiring insulation layer to be connected to the channels; and wiring lines electrically connected to the channels through the channel plugs,

wherein upper surfaces of the dummy channels are entirely covered with the wiring insulation layer, such that the dummy channels are not electrically connected to the wiring lines.

4. The semiconductor device as claimed in claim 3, wherein each of the wiring lines connects two adjacent channels of the channels along the second direction.

5. The semiconductor device as claimed in claim 1, wherein the second dummy channel includes a plurality of second dummy channels passing through the gate connection portion.

6. The semiconductor device as claimed in claim 5, wherein the plurality of second dummy channels are arranged in a row along the first direction.

7. The semiconductor device as claimed in claim 1, wherein:

the gate electrodes include contact regions at edges thereof, respectively, a lower gate electrode of the gate electrodes extending farther in the first direction than an upper gate electrode of the gate electrodes,

the first dummy channels are at a boundary of the contact regions, and

the second dummy channel is in the contact regions.

8. The semiconductor device as claimed in claim 1, further comprising upper isolation regions extending in the first direction, and passing through at least one of gate electrode in an uppermost portion among the gate electrodes.

19

9. The semiconductor device as claimed in claim 1, wherein the dummy channels further include third dummy channels arranged in the first region adjacent to the second region.

10. A semiconductor device, comprising:
gate electrodes stacked in a direction perpendicular to an upper surface of a substrate, each of the gate electrodes including:
subgate electrodes spaced apart from each other, and a gate connection portion connecting to each other subgate electrodes at a same level;
isolation regions extending in a first direction and passing through the gate electrodes, the isolation regions being spaced apart from each other in the first direction;
channels extending through the gate electrodes perpendicularly to the upper surface of the substrate;
a dummy channel extending perpendicularly to the upper surface of the substrate, the dummy channel passing through the gate connections portion;
a wiring insulation layer on the channels and the dummy channel; and
channel plugs passing through the wiring insulation layer and connecting the channels and wiring lines on the channel plugs,
wherein the gate connection portion is between adjacent ones of the isolation regions, and
wherein an upper surface of the dummy channel is entirely covered with the wiring insulation layer, such that the dummy channel is not electrically connected to the wiring lines.

11. The semiconductor device as claimed in claim 10, further comprising a lower isolation region passing through at least one gate electrode in a lowermost portion among the gate electrodes, the gate connection portion overlapping the lower isolation region, in a plan-view.

12. A semiconductor device, comprising:
a substrate having a first region and a second region;
gate electrodes stacked perpendicularly to an upper surface of the substrate in the first region, and extending to different lengths in a first direction in the second region;
first isolation regions extended in the first direction while passing through the gate electrodes in the first region and the second region, the first isolation regions being spaced apart from each other in a second direction perpendicular to the first direction;

20

second isolation regions passing through the gate electrodes between the first isolation regions, the second isolation regions being spaced apart from each other in the first direction;

channels extending perpendicularly to the upper surface of the substrate through the gate electrodes in the first region;

dummy channels extending perpendicularly to the upper surface of the substrate through the gate electrodes in the second region, the dummy channels including first dummy channels arranged in rows and columns and a second dummy channel in a separation region in which adjacent ones of the second isolation regions are spaced apart from each other in the first direction;

upper isolation regions extending in the first direction, and passing through at least one gate electrode in an uppermost portion among the gate electrodes, between the second isolation regions and each of the first isolation regions; and

a lower isolation region passing through at least one gate electrode in a lowermost portion among the gate electrodes, in a region including the separation region.

13. The semiconductor device as claimed in claim 12, wherein the second dummy channel passes through the lower isolation region.

14. The semiconductor device as claimed in claim 12, further comprising an auxiliary upper isolation region in a region including the separation region, and passing through at least one gate electrode in an uppermost portion among the gate electrodes.

15. The semiconductor device as claimed in claim 14, wherein the auxiliary upper isolation region overlaps one of the upper isolation regions, in a plan-view.

16. The semiconductor device as claimed in claim 12, wherein the second dummy channel is within an imaginary extended region of the second separation regions along the first direction.

17. The semiconductor device as claimed in claim 12, wherein the second dummy channel is shifted from the columns of the first dummy channels extending in the second direction.

18. The semiconductor device as claimed in claim 12, wherein the second dummy channel is between the rows of the first dummy channels extending in the first direction.

19. The semiconductor device as claimed in claim 12, wherein the dummy channels are in a floating state in which an electrical signal is not applied.

* * * * *