



- (51) International Patent Classification:  
E05G 1/06 (2006.01) E05G 1/08 (2006.01)
- (21) International Application Number:  
PCT/US2017/024867
- (22) International Filing Date:  
29 March 2017 (29.03.2017)
- (25) Filing Language: English
- (26) Publication Language: English
- (30) Priority Data:  
62/314,904 29 March 2016 (29.03.2016) US
- (72) Inventor; and
- (71) Applicant : BOECKENSTEDT, Bartholomew [US/US];  
19020 97th Avenue Ct E, Puyallup, WA 98375 (US).
- (74) Agents: MARSH, Beverly A. et al.; Standley Law Group  
LLP, 6300 Riverside Drive, Dublin, OH 43017 (US).
- (81) Designated States (unless otherwise indicated, for every  
kind of national protection available): AE, AG, AL, AM,  
AO, AT, AU, AZ, BA, BB, BG, BH, BN, BR, BW, BY,  
BZ, CA, CH, CL, CN, CO, CR, CU, CZ, DE, DJ, DK, DM,  
DO, DZ, EC, EE, EG, ES, FI, GB, GD, GE, GH, GM, GT,

HN, HR, HU, ID, IL, IN, IR, IS, JP, KE, KG, KH, KN,  
KP, KR, KW, KZ, LA, LC, LK, LR, LS, LU, LY, MA,  
MD, ME, MG, MK, MN, MW, MX, MY, MZ, NA, NG,  
NI, NO, NZ, OM, PA, PE, PG, PH, PL, PT, QA, RO, RS,  
RU, RW, SA, SC, SD, SE, SG, SK, SL, SM, ST, SV, SY,  
TH, TJ, TM, TN, TR, TT, TZ, UA, UG, US, UZ, VC, VN,  
ZA, ZM, ZW.

(84) Designated States (unless otherwise indicated, for every  
kind of regional protection available): ARIPO (BW, GH,  
GM, KE, LR, LS, MW, MZ, NA, RW, SD, SL, ST, SZ,  
TZ, UG, ZM, ZW), Eurasian (AM, AZ, BY, KG, KZ, RU,  
TJ, TM), European (AL, AT, BE, BG, CH, CY, CZ, DE,  
DK, EE, ES, FI, FR, GB, GR, HR, HU, IE, IS, IT, LT, LU,  
LV, MC, MK, MT, NL, NO, PL, PT, RO, RS, SE, SI, SK,  
SM, TR), OAPI (BF, BJ, CF, CG, CI, CM, GA, GN, GQ,  
GW, KM, ML, MR, NE, SN, TD, TG).

**Declarations under Rule 4.17:**

— of inventorship (Rule 4.17(iv))

**Published:**

— with international search report (Art. 21(3))

(54) Title: SECURE STORAGE DEVICE

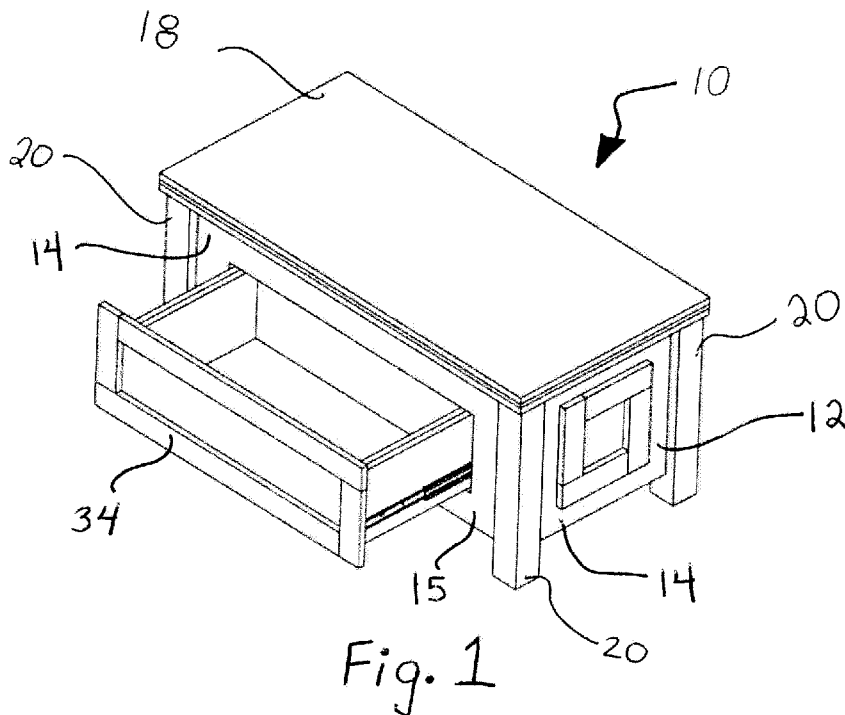

(57) Abstract: A secure storage device that contains multiple compartments under a table top. The table top may move laterally to allow authorized users to access storage areas. A drawer in the device may also be accessed by an authorized user. The movement of the table top and drawer is directed by a central computer in communication with a biometric sensor located on the device. The central computer may be programmed to allow different types of access to the device based upon fingerprints or other biometric information from a user.

WO 2017/173003 A1

## **SECURE STORAGE DEVICE**

### **CROSS-REFERENCE TO RELATED APPLICATIONS**

**[0001]** This application claims the filing benefit of U.S. Provisional Application No. 62/314,904, filed March 29, 2016, and makes a claim of priority thereto. The entire contents of the '904 provisional application are hereby incorporated by reference as if fully recited herein.

### **TECHNICAL FIELD**

**[0002]** Exemplary systems, devices, and methods are directed to secure storage.

### **BACKGROUND AND SUMMARY**

**[0003]** Many people own guns, jewelry, and other dangerous or valuable objects that they wish to keep securely hidden from view in their homes. However, it is difficult to securely store items in devices that require a passcode or physical key, as passcodes and keys may be difficult to locate or remember, especially in an emergency. Particularly for gun owners, who may wish to access a gun quickly in the event of a home invasion or other safety threat, it is desirable to be able to access a storage device without having to locate a key or remember a code.

**[0004]** It is also desirable to be able to remotely monitor the status of a storage device and determine if it is open or closed, as well as to be able to open or close a storage device remotely. It is further desirable to be able to monitor which person(s) may have access to a storage device.

**[0005]** Homeowners who desire quick access to their valuables recognize that it is ideal if such valuables are stored in the main living quarters, hidden in “plain sight.” This allows homeowners to easily and quickly access their belongings without having to walk down to a basement, attic, or closet where many people otherwise store their guns and valuables.

**[0006]** Exemplary embodiments described herein address these problems and more. Exemplary embodiments provide a secure storage device that uses a biometric sensor to ensure that only approved persons can access stored objects. Exemplary embodiments provide a secure storage device with multiple compartments, allowing for access to each compartment to be monitored, recorded, and only given to authorized persons. Exemplary embodiments also provide a device that can be used as a coffee table, has a bidirectional table top that can move in two directions to provide access to multiple compartments, and also has a drawer for storage.

**[0007]** Other aspects and features of the invention will become apparent to those skilled in the art upon review of the following detailed description of exemplary embodiments along with the accompanying drawing figures.

### **BRIEF DESCRIPTION OF THE DRAWINGS**

**[0008]** **FIGURE 1** is a perspective view of an exemplary embodiment of a secure storage device, wherein the drawer is in an open position;

**[0009]** **FIGURE 2** is a top plan view of the device of FIG. 1, wherein the drawer is in an open position;

- [0010] **FIGURE 3** is a side elevational view of the device of FIG. 1, wherein the drawer is in an open position;
- [0011] **FIGURE 4** is an exploded perspective view of the device of FIG 1;
- [0012] **FIGURE 5** is a front elevational view of the device of FIG. 1, with the drawer in a closed position;
- [0013] **FIGURE 6** is a cross-sectional view of the device of FIG. 1, taken along line A-A of FIG. 5;
- [0014] **FIGURE 7** is a perspective view of the device of FIG 1, with the drawer and table top in open positions;
- [0015] **FIGURE 8** is an illustration of a perspective view of the device of FIG 1, with the drawer and table top in open positions and surfaces transparent;
- [0016] **FIGURE 9** is a perspective view of the device of FIG. 1, with the drawer in an open position and the table top in an exaggerated open position and with top layers of the table top and bottom surface of the storage areas omitted;
- [0017] **FIGURE 10** is a perspective view of the device of FIG. 1, with the drawer and table top omitted;
- [0018] **FIGURE 11** is a perspective view of the device of FIG. 1, with the drawer, table top, and bottom surfaces of the storage areas omitted;
- [0019] **FIGURE 12** is an illustration of a top plan view of the device of FIG. 1, with surfaces transparent;
- [0020] **FIGURE 13** is an illustration of a front elevational view of the device of FIG. 1, with table top omitted and surfaces transparent;

- [0021] **FIGURE 14** is an illustration of a side elevational view of the device of FIG. 1, with table top omitted and surfaces transparent;
- [0022] **FIGURE 15** is a top cross-sectional view of the device of FIG. 1, taken along line B-B of FIG. 13;
- [0023] **FIGURE 16** is a perspective view of a cam lock mechanism;
- [0024] **FIGURE 17** is a perspective view of a cam lock of an exemplary embodiment;
- [0025] **FIGURE 18** is a perspective view of an exemplary embodiment of a rack; and
- [0026] **FIGURE 19** is a perspective view of a pinion motor;
- [0027] **FIGURE 20** is a bottom plan view of the device of FIG. 1; and
- [0028] **FIGURE 21** is a side view of an embodiment of an offset parallel drive shaft.

#### **DETAILED DESCRIPTION OF THE EXEMPLARY EMBODIMENTS**

- [0029] Referring to the figures, an exemplary embodiment of a storage device is shown. As shown in at least Figs. 1-3, the device **10** is comprised of a generally rectangular outer chest **12** having four sides **14** including a front side **15**, a bottom **16**, a table top **18**, and four legs **20**. The four sides **14** and bottom **16** define a generally rectangular inner cavity **22**. The table top **18** is horizontally disposed above the inner cavity **22** and has a generally planar surface.
- [0030] Internally, the device **10** is generally comprised of an upper compartment **30** and a lower compartment **32**. In the lower compartment **32** is located a drawer **34** that is slidably mounted to the chest **12** and opens through an aperture **36** in the front side **15** of the outer chest **12**. The drawer **34** is slidably mounted to the chest **12** through a pair of drawer slide assemblies **38** located on either side of the drawer **34**.

**[0031]** The upper compartment **30** of the chest **12** contains two storage areas **40** separated from one another and defined in part by a central motor compartment **42** that spans the inner depth of the upper compartment **30**. A shelf **41** provides the bottom of the two storage areas **40** and the central motor compartment **42**.

**[0032]** The table top **18** is able to move relative to the inner cavity from a closed position, wherein it covers the entire inner cavity **22**, as shown in Fig.1, for example, to an open position, wherein the inner cavity **22** is at least partially exposed and the contents of at least one of the storage areas **40** may be accessed by a user. Figs. 7-9 illustrate the table top **18** in open positions, wherein both storage areas **40** may be accessed. The table top **18** may move in either direction, and to varying extents as desired. The table top **18** may only open enough in either direction to expose just one storage area **40** at a time. Depending on the embodiment, different numbers and configurations of storage areas may exist in the upper compartment **30**.

**[0033]** The means for moving the table top **18** is illustrated in Figs. 4, 7, 8, 9, and 11. On the bottom surface of the table top **18** are two rail slides **44** located in parallel fashion. Each rail slide **44** is positioned to slidably engage with one of two rail slide carriages **46** located in the motor compartment **44**. The rail slide carriages **46** guide the movement of the table top **18** from a closed to open position, and vice versa. The movement of the table top **18** is actuated by a rack and pinion assembly. A rack **48** is located on the bottom surface of the table top **18**, in between the rail slides **44**. An exemplary embodiment of a rack is shown in Fig. 18. Inside the motor compartment is a pinion motor **50** positioned such that when in operation it engages with the rack **48** on the bottom surface of the table top **18** and induces lateral movement of the table top **18**. In other exemplary

embodiments different assemblies and means may be used to cause and guide movement of the table top.

**[0034]** As illustrated in Figs. 4 – 6, in this exemplary embodiment the table top is comprised of multiple layers **18a**, **18b**, and **18c**, and the middle and bottom layers **18b**, **18c**, contain apertures **52** sized and positioned to accept the rail slides **44** and allow the rail slides **44** to be recessed. This may provide sufficient clearance to the rail slides **44** such that the table top **18** slides smoothly over the four sides **14** of the chest **12** and without obstruction. Rollers **49** protruding from the top surface of the front and back sides **14** of the chest also aid in allowing the table top to move smoothly. Fig. 9 shows the table top **18** in an open position, exaggerated to allow viewing of the motor compartment **42**, with the top layer **18a** of the table top omitted, exposing the rail slides **44** for view. In some embodiments a single rail slide **44** and a single rail slide carriage **46** may be used to guide the movement of the table top **18**.

**[0035]** Referring to Fig. 4, and as also shown in Fig. 11, the table top **18** may be secured into a position by four cam lock mechanisms **54** located within the sides of the chest, in proximate location to each of the four corners. Operation of the cam lock mechanisms is **54** controlled by pairs of 90-degree drives **56**, each pair of drives **56** associated with a motor **58**. The drives **56** and associated motors **58** are positioned on each end of the chest, and operate the two cam lock mechanisms **54** on their respective end (drive and mechanism on one end not shown).

**[0036]** Referring to Figs. 10-15, securing of the drawer **34** is performed by two cam locks **60** located within the lower compartment **32**. A hex long bar **62** runs through each cam lock **60** and is rotated by a dedicated motor. Rotation of the hex long bar **62** causes

the cam locks **60** to engage or disengage, depending on the rotations. When the cam locks are engaged the drawer cannot be opened. An embodiment of a cam lock is shown in Fig. 17, and an embodiment of 90-degree drive assembly **56** is shown in Fig. 16. In other embodiments different types of locks and latches may be used to hold the table top and drawer in secure “closed” positions. Fig. 19 is an exemplary embodiment of a motor that may be used as a table top motor **50**. Fig. 21 illustrates an offset parallel drive shaft **70** comprising two 90-degree gears **72** on either end of an internal shaft **74** that may be used in some embodiments instead of a pair of 90-degree drives.

**[0037]** In the exemplary embodiment the operation of each motor is controlled by a central computer **80** located inside the lower compartment **12**. The central computer **80** is located underneath the front drawer **34** as shown in Fig. 11, although in other embodiments the central computer **80** may be in a different location. In some exemplary embodiments the motors are hard wired to the central computer **80**, and in other embodiments the motors communicate with the central computer **80** through wireless means. The central computer **80** controls the operation of the respective motors to cause the table top **18** and the drawer **34** to lock, and the table top **18** to move. In other embodiments the drawer may be automated as well and in such embodiments the movement of the drawer would also be controlled by the central computer.

**[0038]** As shown in Fig. 20, a biometric sensor **84** is located in the lower compartment, located out of view from a casual observer. The biometric sensor **84** is in communication with the central computer **80** and transmits information to the central computer regarding fingerprint information. A biometric sensor that reads fingerprints may be obtained from many sources, including from SparkFun ([www.sparkfun.com](http://www.sparkfun.com), Boulder, Colorado). The

biometric sensor **84** may either be hard-wired to the central computer **80** or communicate with the central computer **80** wirelessly. The biometric sensor may be programmed to recognize multiple fingerprints, which may be from the same person or different persons. Accordingly, an authorized user may use one finger to obtain access to one of the storage areas **40**, and a different fingerprint to obtain access to another storage area **40**, or to the drawer **34**. Some persons may only be authorized to access a single storage area or the drawer. One of ordinary skill in the art will appreciate that authorized permissions recognized by the biometric sensor may be tailored as desired.

**[0039]** The central computer may be programmed to direct different types of access to the device based on the fingerprint of a user. For example, programming may dictate that if a particular user places their index finger on the sensor and it is accepted, the table top may slide to the left, exposing the upper right compartment and allowing a user to either access items in the upper right compartment or leave items in the upper right compartment. The same user may then place their index finger on the sensor the table top will close and keep the upper right compartment secure. However, if the same user places their ring finger on the sensor and it is accepted, the central computer may grant access to the upper left compartment, and direct the movement of the table top motor to move the table top to the right, thereby exposing the upper left compartment. Similarly, a thumb print by the same user may allow access to the drawer.

**[0040]** The central computer may also be programmed to give different access permissions to different users. For example, one user may only have access to the upper compartments, while other users may only have access to the front drawer. This may be done through the establishment role-based permissions, where an administrator sets up

different roles and corresponding access to be executed by the central computer in communication with both the biometric sensor and the motors.

**[0041]** In some embodiments, the device may be programmed to expose the upper compartments and/or open the bottom drawer while also sending an alert to notify security, police, or other emergency personnel that someone is in danger. For example, in an embodiment the same fingers on an approved user may allow for the same functions (e.g., each thumb opens the bottom drawer, each index finger slides the table top to the left exposing the upper right compartment). However, if the user uses their left hand, the device may not only allow access to the desired compartment or drawer, but it may also send a silent alert to a police department. This allows a user in a confrontational setting (such as a home break-in) to access the device but also alert authorities that they are in danger. One of ordinary skill in the art will recognize that the device can be programmed in variety of various ways and that different types of biometric information may be used to allow access. For example, in some embodiments voice recognition or retinal scan technology may be used, as well as radio frequency identification devices.

**[0042]** In an exemplary embodiment the device **10** is powered through a hardwire connection to a power source. The hardwiring may be routed through one of the legs of the chest, which also serves to keep it hidden. In some embodiments the device may also contain an internal battery backup for power outage events. In some embodiments the particular leg of the chest where the wiring is routed may be reinforced with steel or other materials to prohibit removal and/or sawing off of the leg to cut power to the device. In other embodiments the device may also have a power cord that can be plugged into an outlet. As shown in Fig. 8, in some embodiments one or more legs **20** on a device

may be bored with a hole **76** to allow for the insertion of a metal screw assembly that can be used to secure the device to the floor. While in figure 8 the holes are only bored through a partial portion of the legs, in other exemplary embodiments the holes may be bored through the entire leg to allow metal screws and other fasteners to be inserted from the top of the leg.

**[0043]** While the embodiments of the figures could be used as a coffee table or table in a household setting, it will be appreciated by one of ordinary skill in the art that other embodiments could be modified to be used as kitchen islands or other types of furniture in a home, office, or commercial setting, making their secure storage functions unknown to visitors and intruders. Furthermore, it will be recognized that the location and amount of drawers and compartments may be modified as desired.

**[0044]** In certain embodiments the device may be remotely controlled and monitored, such as through the use of a smart phone. In such embodiments, communications between the smart phone and device may be made through the use of cell and/or internet, and may be encrypted to protect security. Encryption may be achieved through use of Tor network encryption or other type of network encryption. In such embodiments, a user may receive notifications and alerts on their smart phone or other device. A user may also be notified each time the device is accessed, or when an attempt to access is made, with notification of whether access was allowed or denied.

**[0045]** Exemplary embodiments may include safety sensors installed on the table top or in the upper compartments to prevent the table top from moving when a hand or other object is in the way. Safety sensors may use infrared technology or other motion detecting technology.

**[0046]** Exemplary embodiments may include one or more vibration and/or motion sensors located in one or more positions around the device that can be used to detect the presence of others around the device. Such embodiments may further include means to engage cameras or additional sensors located in proximity to the device to visually record or otherwise monitor the actions of unauthorized persons. In one embodiment, a user can “arm” the device either remotely or manually. In the “armed” mode, the device will close and engage all locks. The device may also detect vibration and/or motion and if detected, will cause cameras in close proximity to activate and record, as well as push video footage to smart phones and other mobile devices. This embodiment allows a user to monitor their home, and know not only if an unauthorized person is in their home, but can let them see what the unauthorized person is doing in their home.

**[0047]** In some embodiments, the device may contain a GPS beacon that is communication with smart phone or other mobile user device. The device may automatically go into “armed” mode when a user’s phone (or other mobile device) is located beyond a pre-determined radius from the device. For example, if a user syncs their smart phone with a storage device having the GPS functionality, the user can program the device to automatically arm when the user’s phone is no longer within a 100 foot radius. This feature can help ensure that the device is armed when the user leaves the home, and reduce the amount of user error.

**[0048]** While in some embodiments the chest may be made primarily of wood, in other embodiments the chest may be made of metal, plastic, and other materials, and combinations thereof, as desired.

**[0049]** While certain exemplary systems, devices, and methods are described in detail above, the scope of the invention is not considered limited by such disclosure, and one of ordinary skill in the art would appreciate that modifications are possible without departing from the spirit of the invention. As such, it is intended that the present invention only be limited by the terms of the appended claims.

WHAT IS CLAIMED IS:

**Claim 1.** A chest comprising:

four sides and a bottom surface defining a generally rectangular inner cavity;  
a substantially planar table top horizontally disposed above the inner cavity, said table top movable between a closed position, wherein the table top covers the entire inner cavity, and an open position, wherein the inner cavity is at least partially exposed;  
a first locking mechanism for securing the table top in a predetermined position relative to the inner cavity;  
a drawer slidably mounted to the front side of the chest for movement between an open position extending in front of the chest and a closed position in the inner cavity;  
a second locking mechanism for securing the drawer in a closed position;  
a sensor mounted on the chest for receiving information about the identity of a user; and  
a computer in communication with the sensor, the computer able to receive information about the identify of a user from the sensor and control access to said inner cavity and said drawer.

**Claim 2.** The chest of Claim 1, wherein:

the sensor is a biometric sensor and the information about the identity of a user is a fingerprint.

**Claim 3.** The chest of Claim 1, wherein:

the first and second locking mechanisms are cam locks.

**Claim 4.** The chest of Claim 1, wherein:

the inner cavity includes at least one storage area that is accessible when the table top is in an open position.

**Claim 5.** The chest of Claim 1, wherein:

the chest is a coffee table.

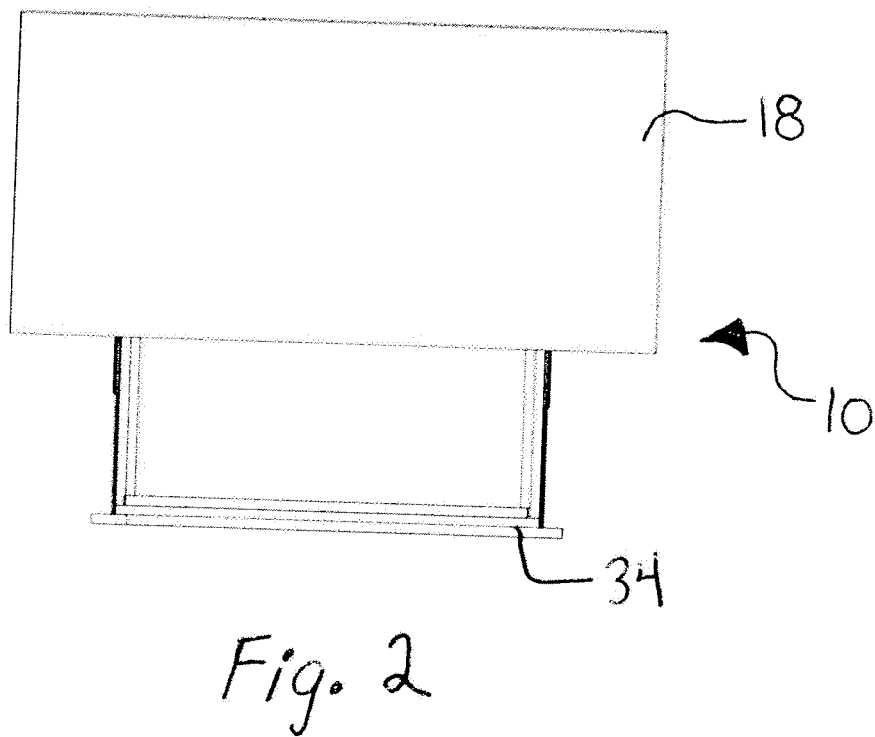
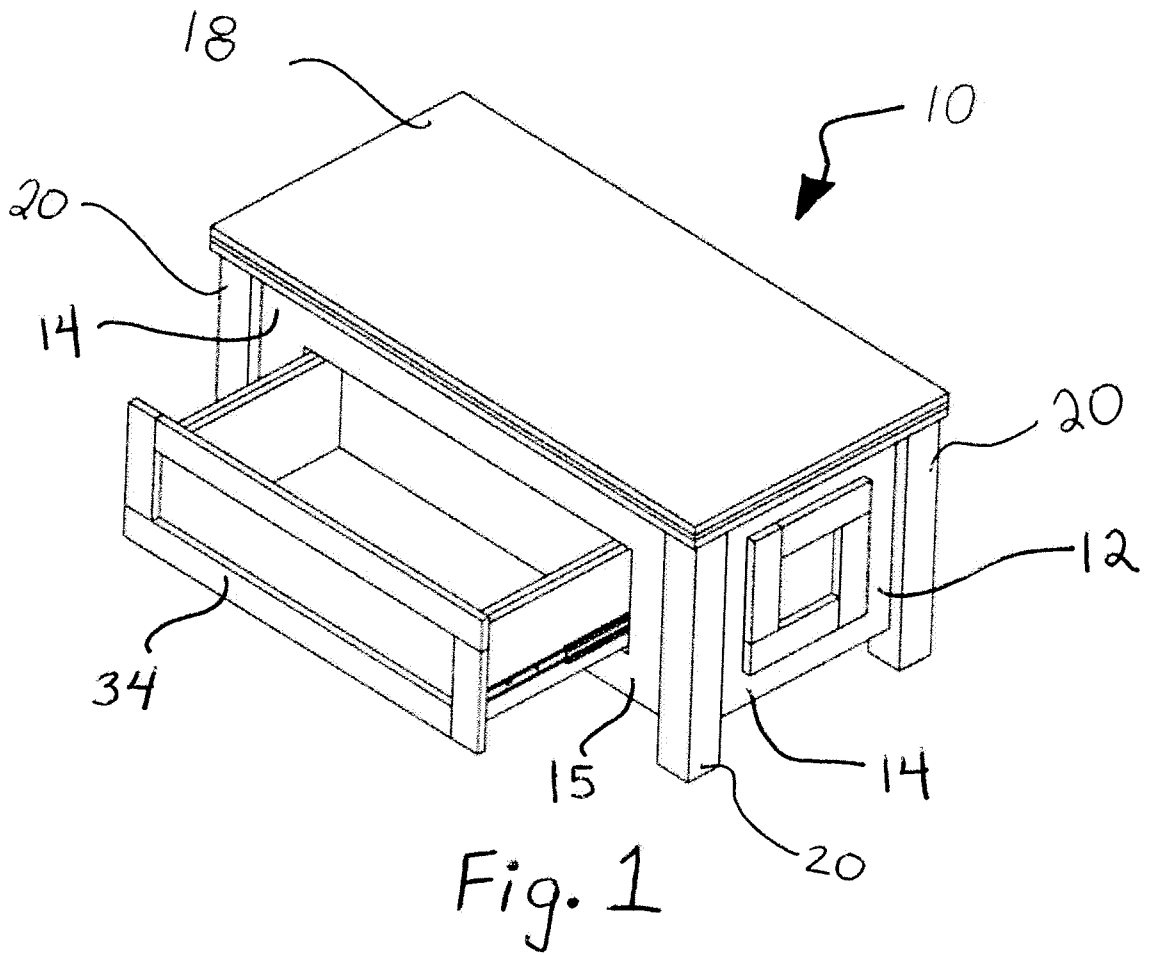

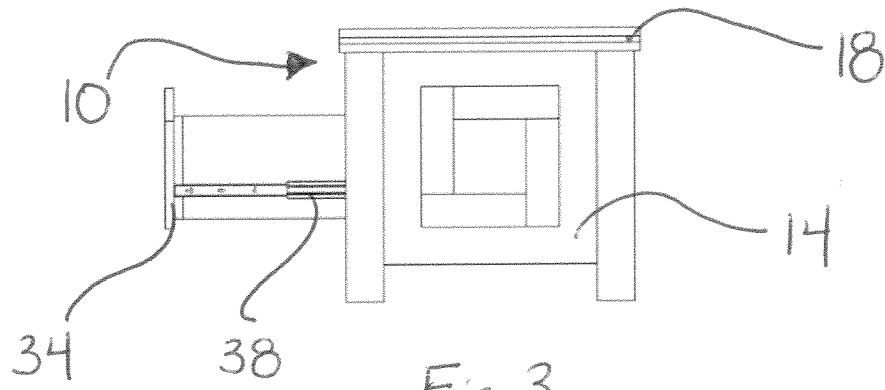

Fig. 3

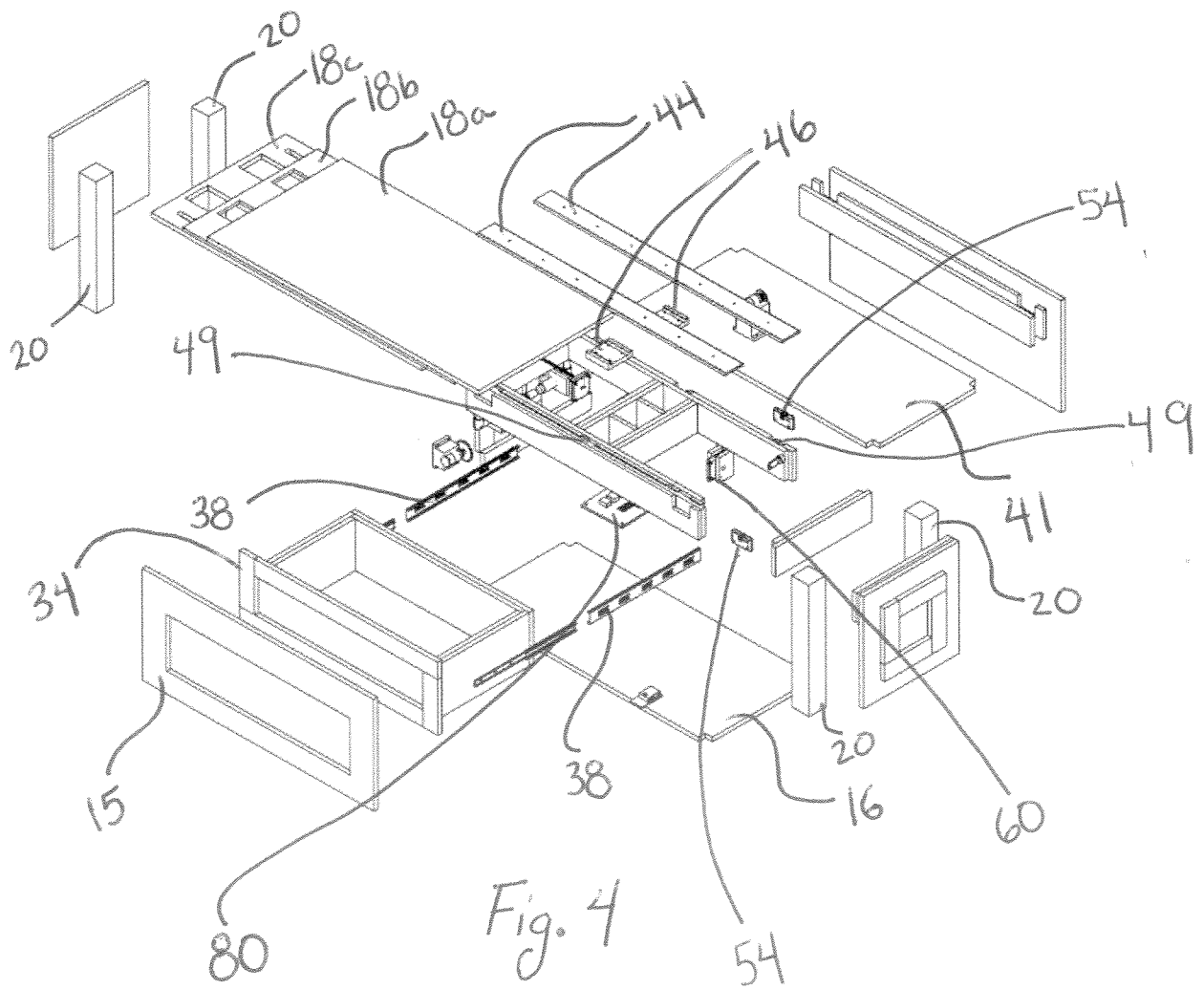

Fig. 4

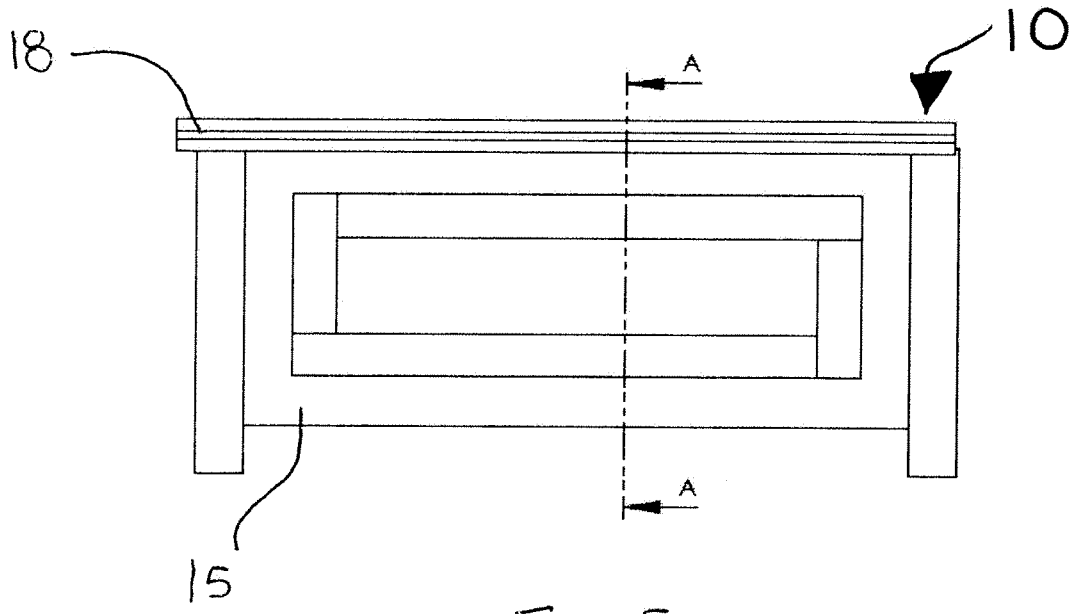

Fig. 5

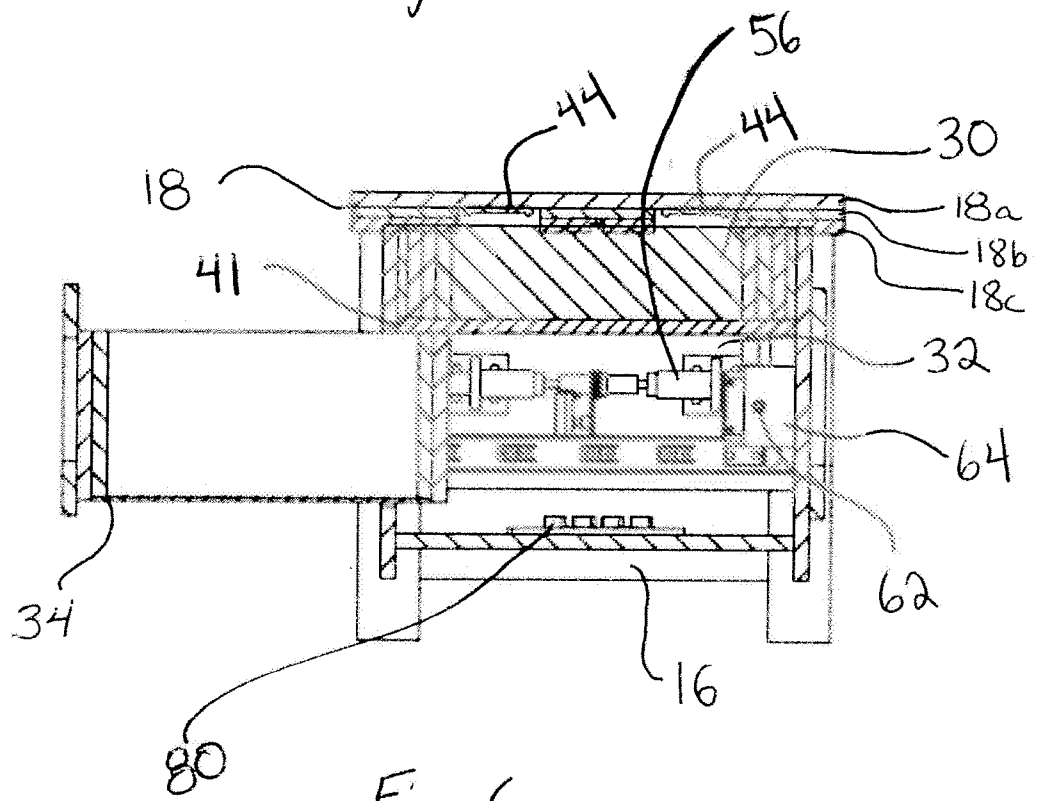

Fig. 6

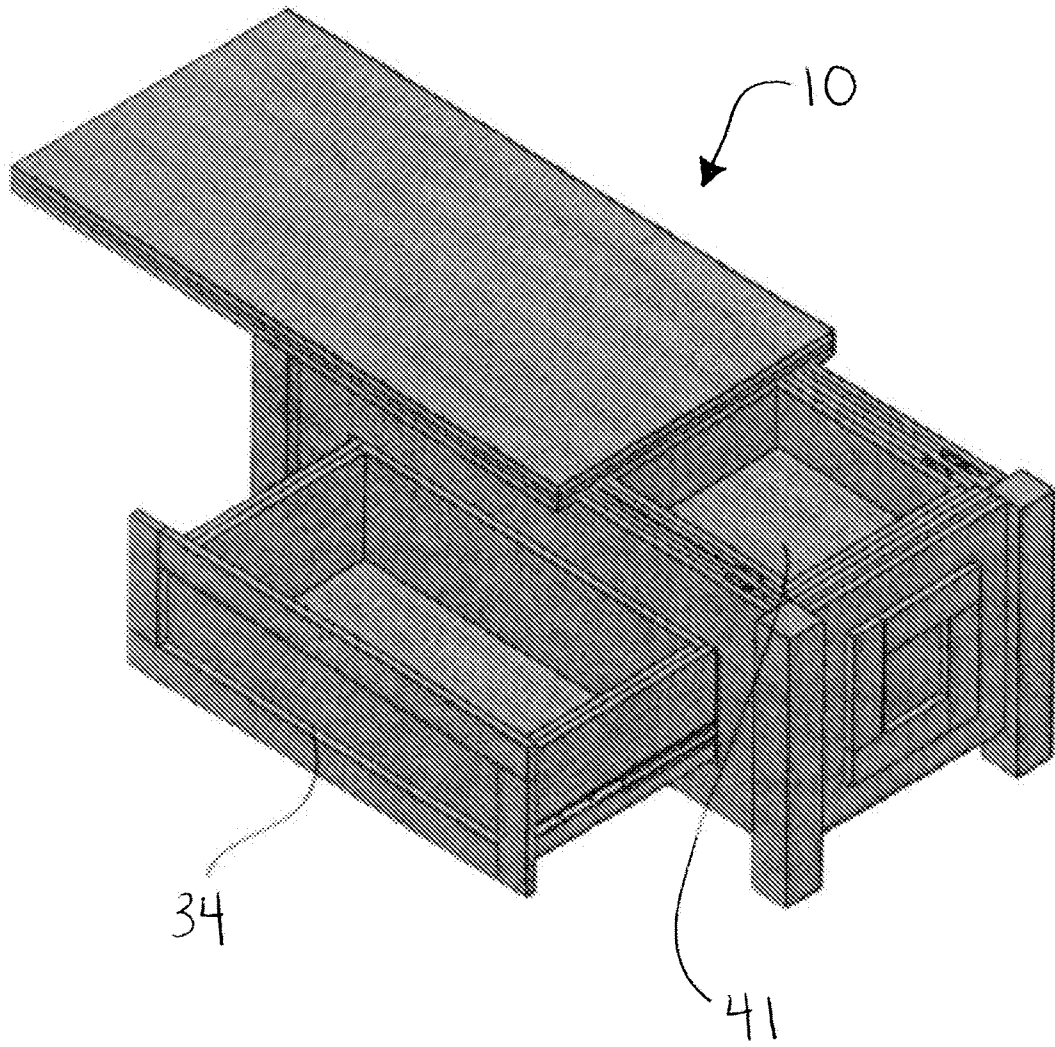

Fig. 7

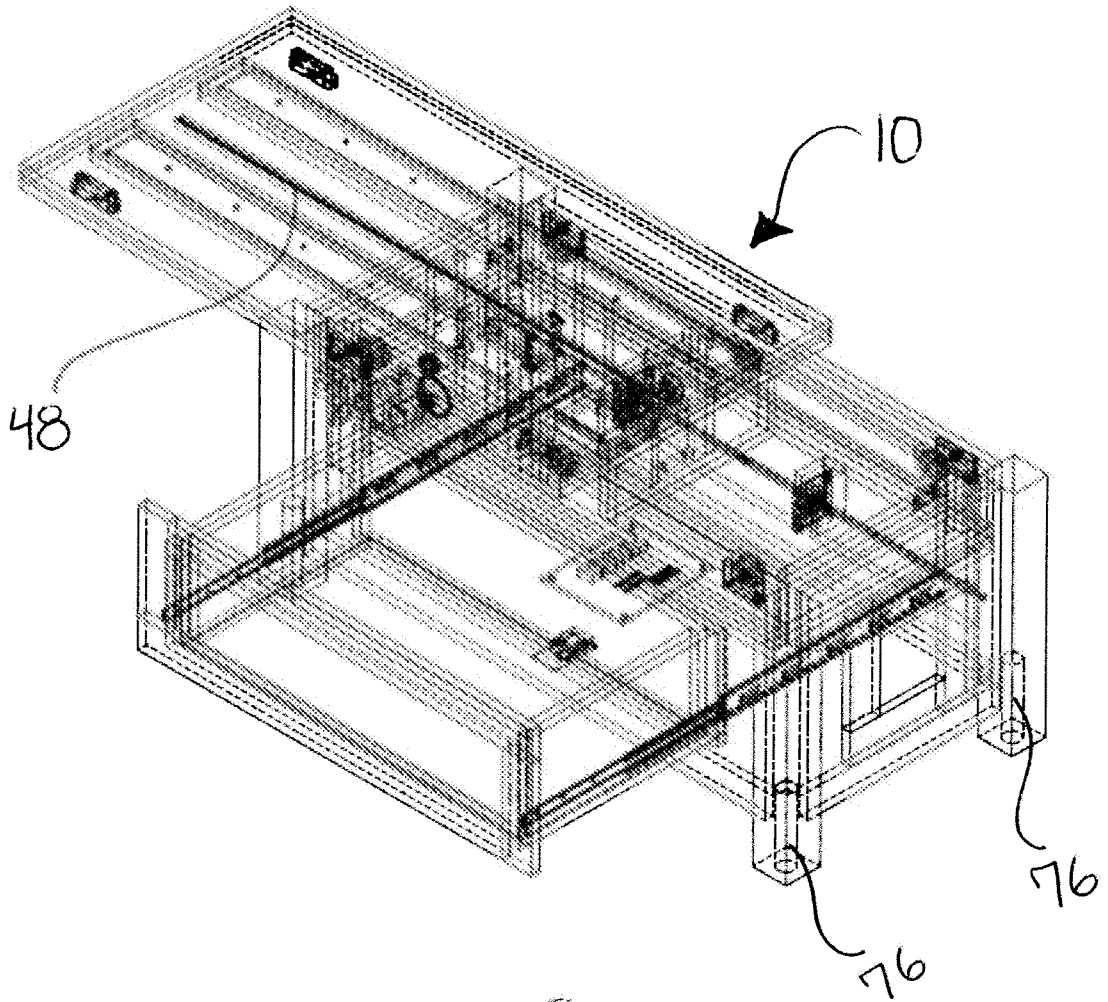

Fig. 8

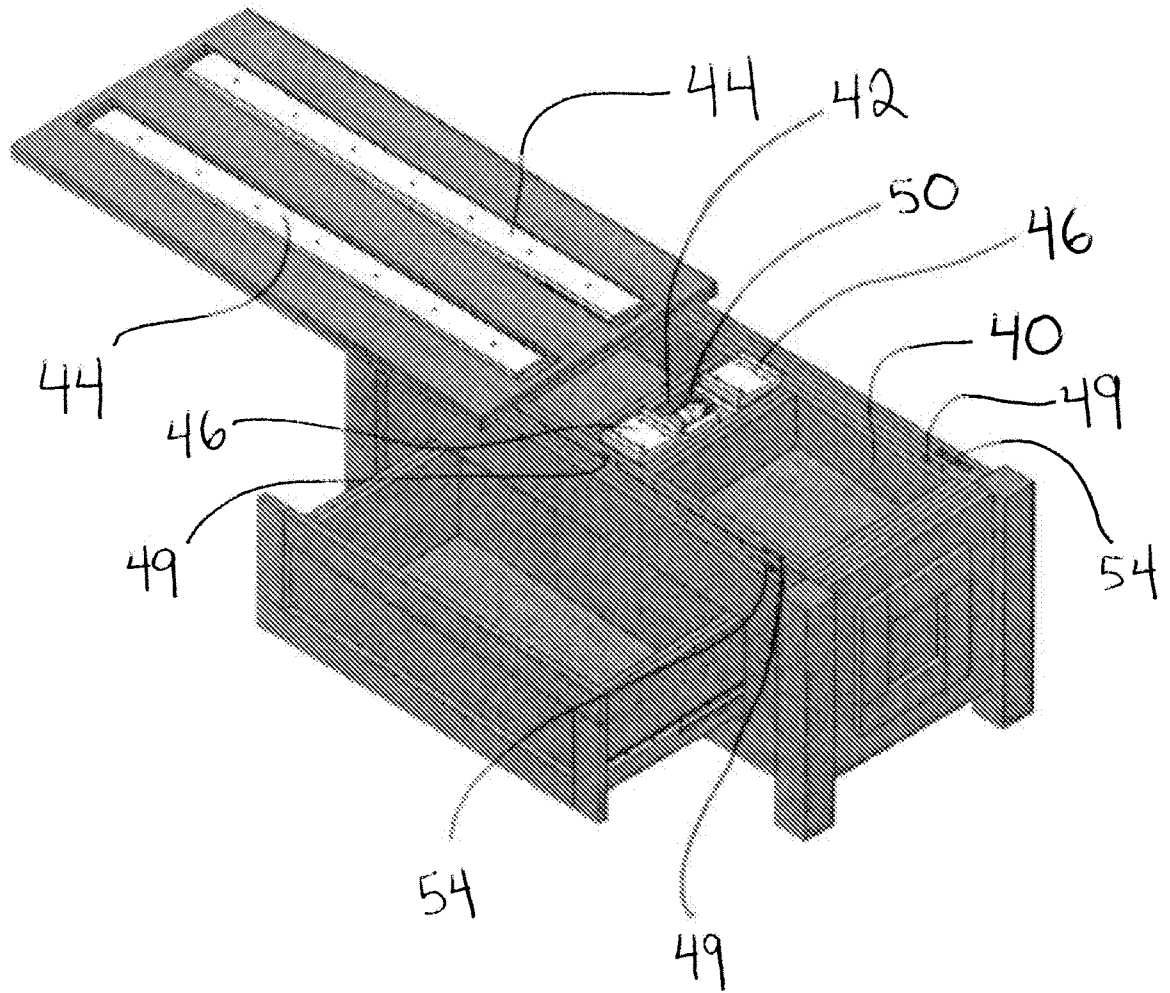

Fig. 9

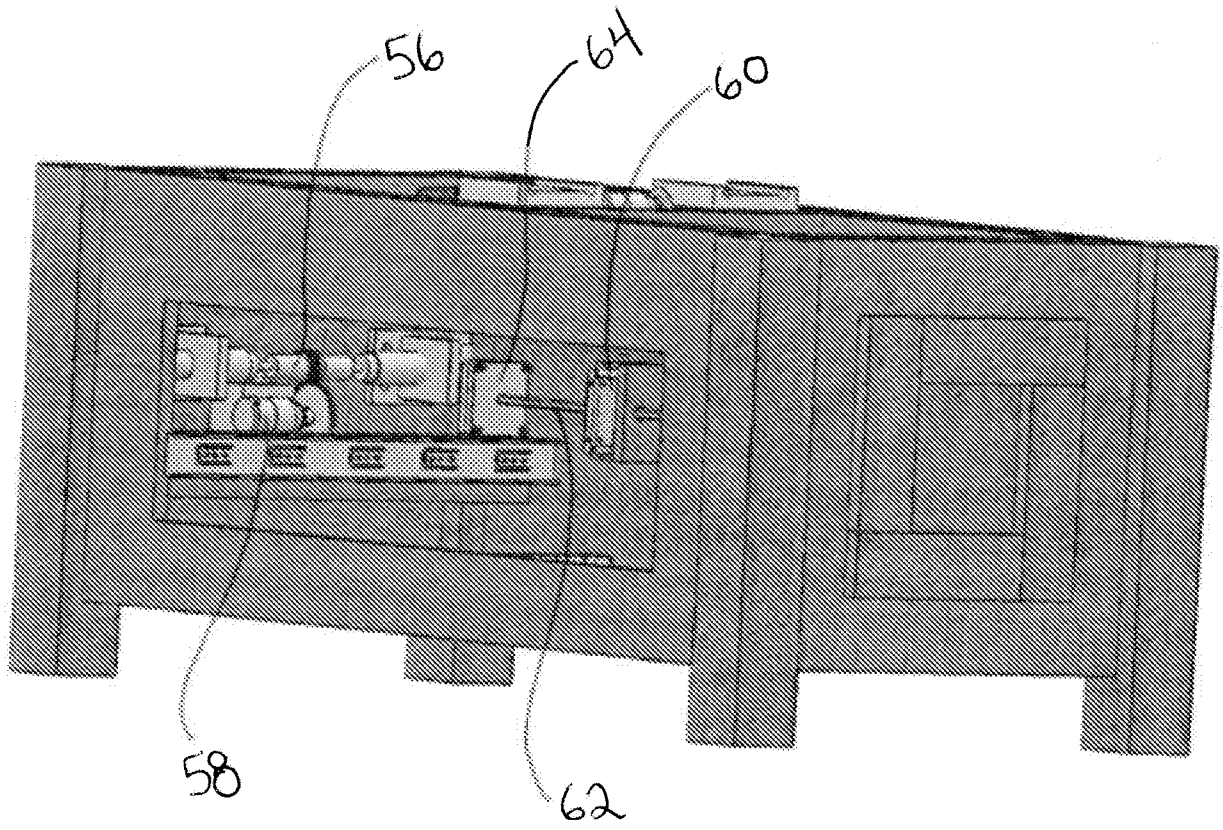

Fig. 10

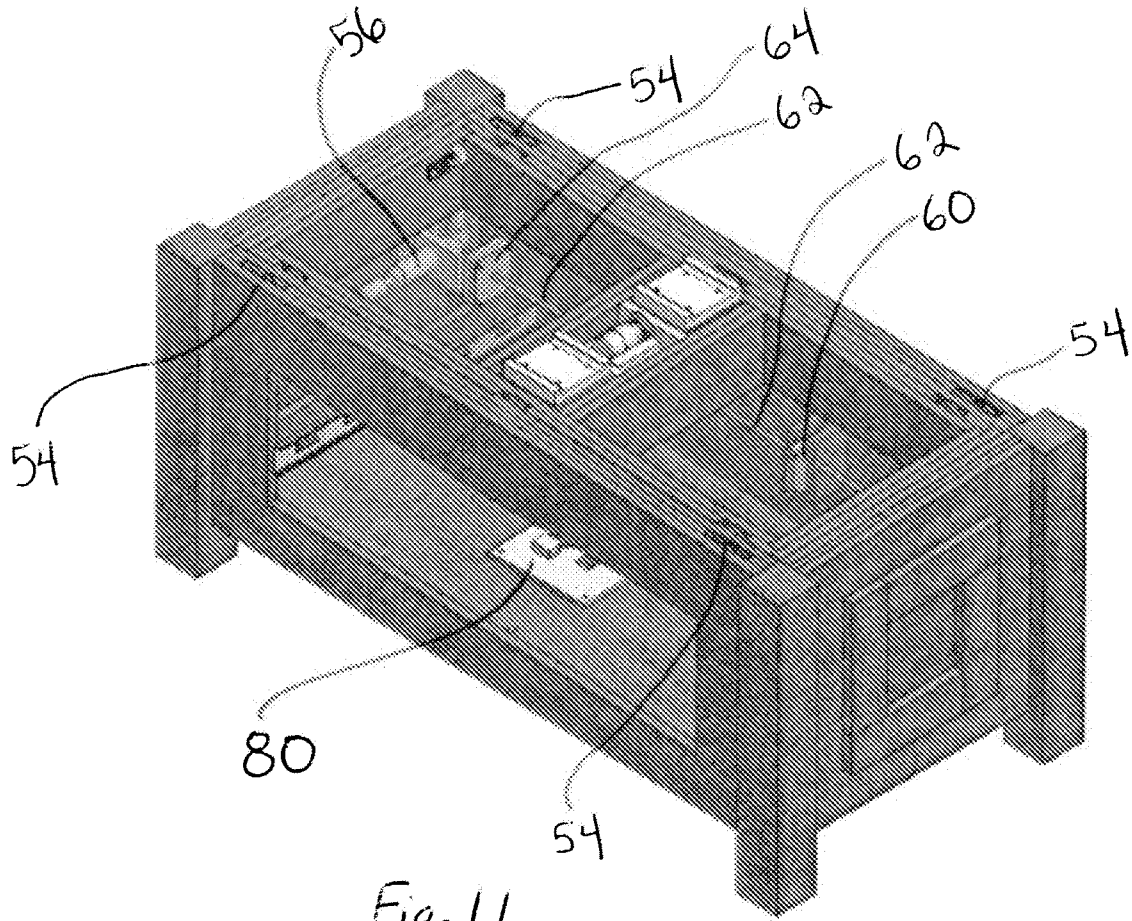

Fig. 11

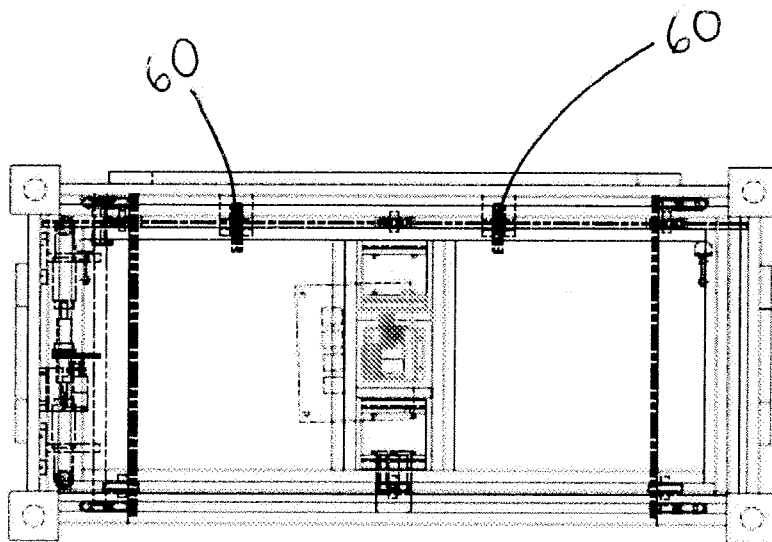

Fig. 12

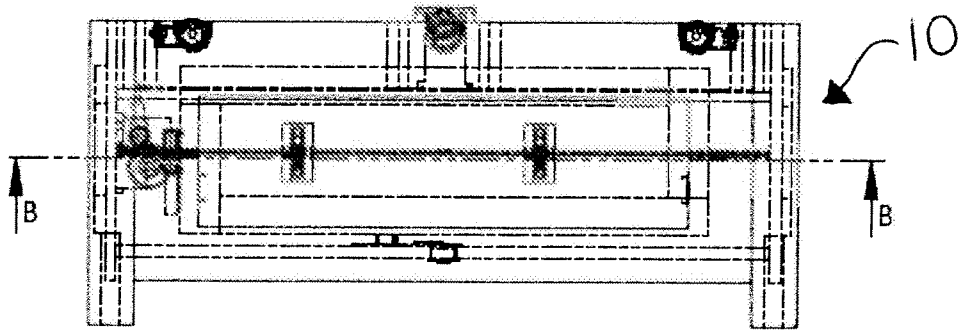

Fig. 13

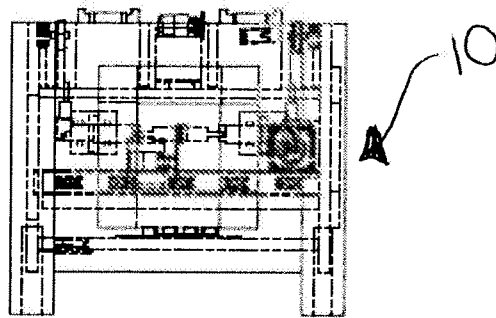

Fig. 14

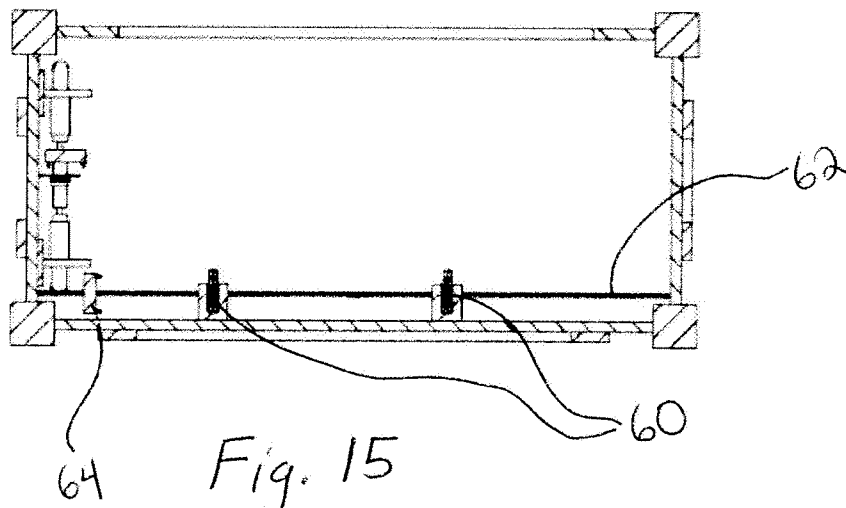

Fig. 15

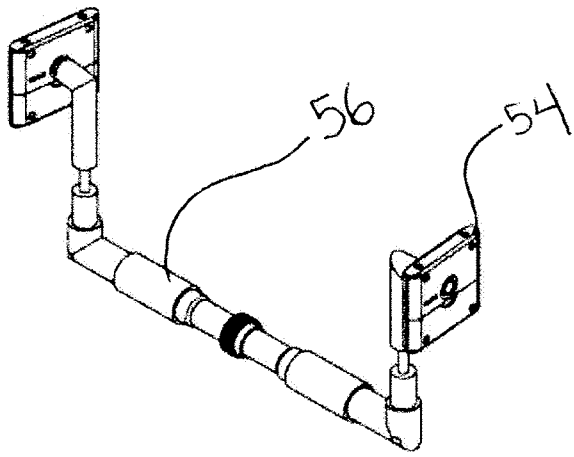

Fig. 16

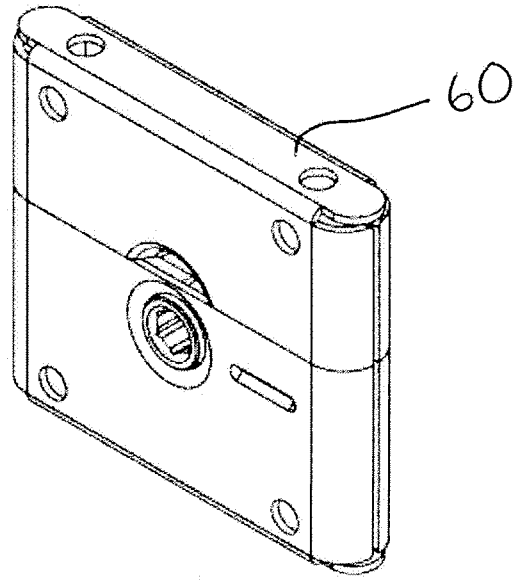

Fig. 17

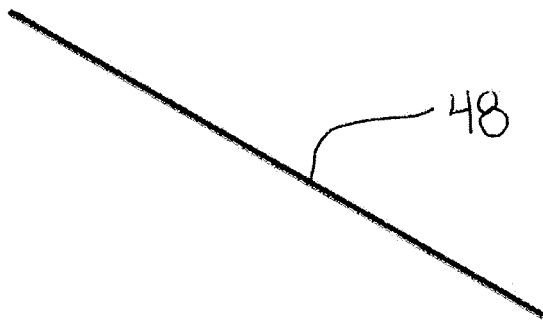

Fig. 18

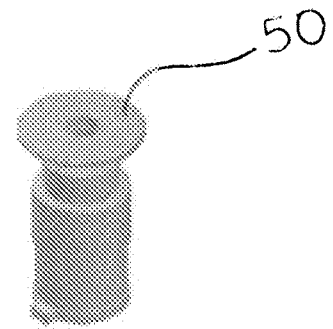

Fig. 19

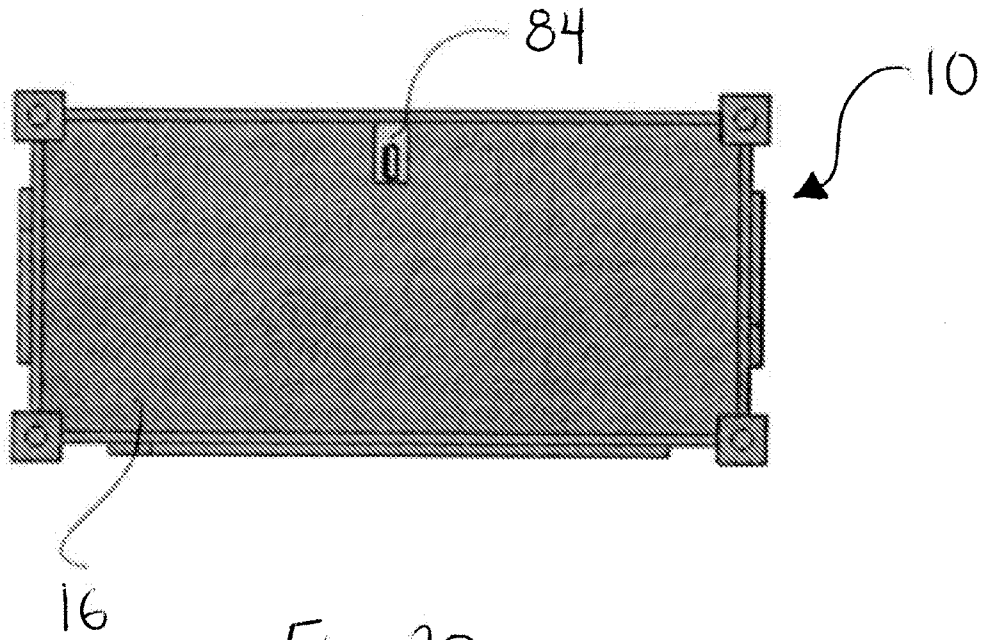

Fig. 20

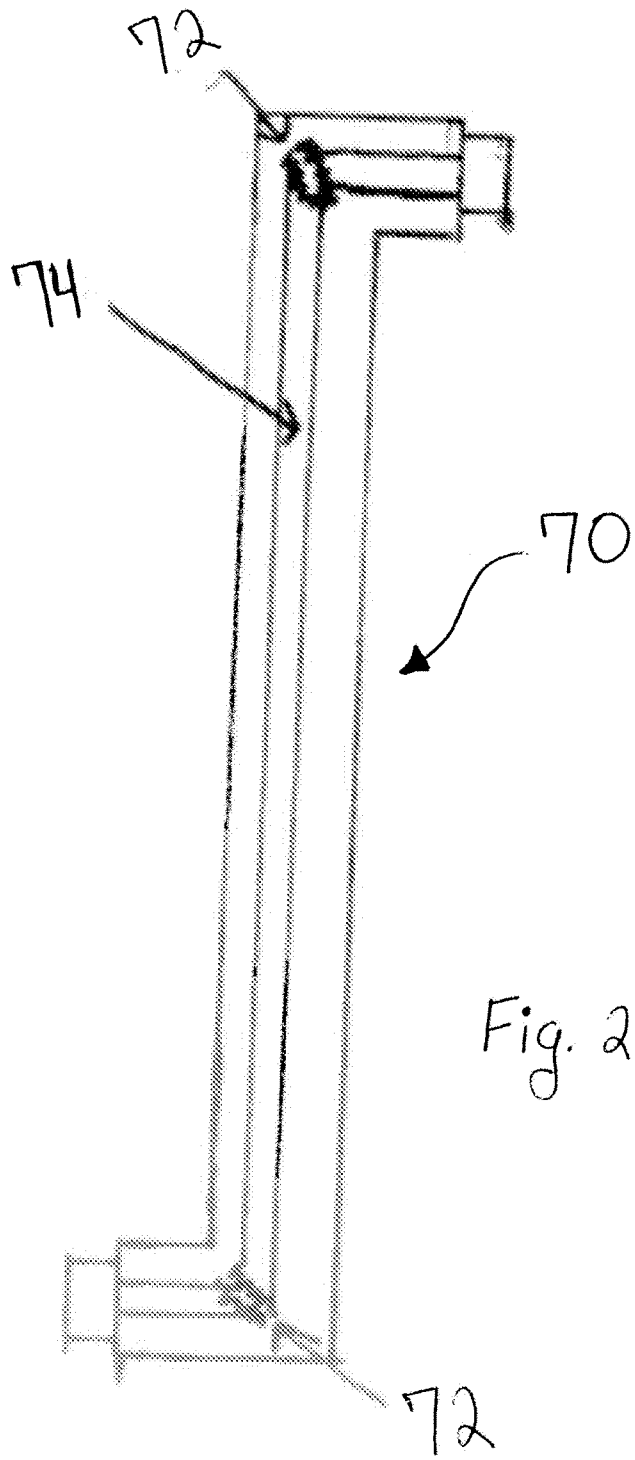

Fig. 21

INTERNATIONAL SEARCH REPORT

International application No.  
PCT/US17/24867

A. CLASSIFICATION OF SUBJECT MATTER

IPC - E05G 1/06, 1/08 (2017.01)  
CPC - A47B 13/081; E05G 1/08, 1/06

According to International Patent Classification (IPC) or to both national classification and IPC

B. FIELDS SEARCHED

Minimum documentation searched (classification system followed by classification symbols)  
See Search History document

Documentation searched other than minimum documentation to the extent that such documents are included in the fields searched  
See Search History document

Electronic data base consulted during the international search (name of data base and, where practicable, search terms used)  
See Search History document

C. DOCUMENTS CONSIDERED TO BE RELEVANT

Category*	Citation of document, with indication, where appropriate, of the relevant passages	Relevant to claim No.
Y	US 2005/0251687 A1 (BACHINSKI THOMAS J) November 10, 2005; Paragraphs [0007]-[0010], [0032], [0038]-[0039]	1-5
Y	"Rustic Oak Storage Coffee Table with Sliding Top and Drawers", Sartra.co.uk. 13 April 2015. Retrieved on 30 May 2017. Retrieved from the Internet: [http://www.sartra.co.uk/living-room-furniture/coffe-tables/rustic-oak-storage-coffee-table]; entire document	1-5

Further documents are listed in the continuation of Box C.  See patent family annex.

\* Special categories of cited documents:

"A" document defining the general state of the art which is not considered to be of particular relevance	"T" later document published after the international filing date or priority date and not in conflict with the application but cited to understand the principle or theory underlying the invention
"E" earlier application or patent but published on or after the international filing date	"X" document of particular relevance; the claimed invention cannot be considered novel or cannot be considered to involve an inventive step when the document is taken alone
"L" document which may throw doubts on priority claim(s) or which is cited to establish the publication date of another citation or other special reason (as specified)	"Y" document of particular relevance; the claimed invention cannot be considered to involve an inventive step when the document is combined with one or more other such documents, such combination being obvious to a person skilled in the art
"O" document referring to an oral disclosure, use, exhibition or other means	"&" document member of the same patent family
"P" document published prior to the international filing date but later than the priority date claimed	

Date of the actual completion of the international search  
06 June 2017 (06.06.2017)

Date of mailing of the international search report  
**27 JUN 2017**

Name and mailing address of the ISA/  
Mail Stop PCT, Attn: ISA/US, Commissioner for Patents  
P.O. Box 1450, Alexandria, Virginia 22313-1450  
Facsimile No. 571-273-8300

Authorized officer  
Shane Thomas  
PCT Helpdesk: 571-272-4300  
PCT OSP: 571-272-7774