

May 23, 1961

J. ROSENKRANZ

2,985,380

SELF-PROPELLED WATER SPRINKLER

Filed Nov. 14, 1958

3 Sheets-Sheet 1

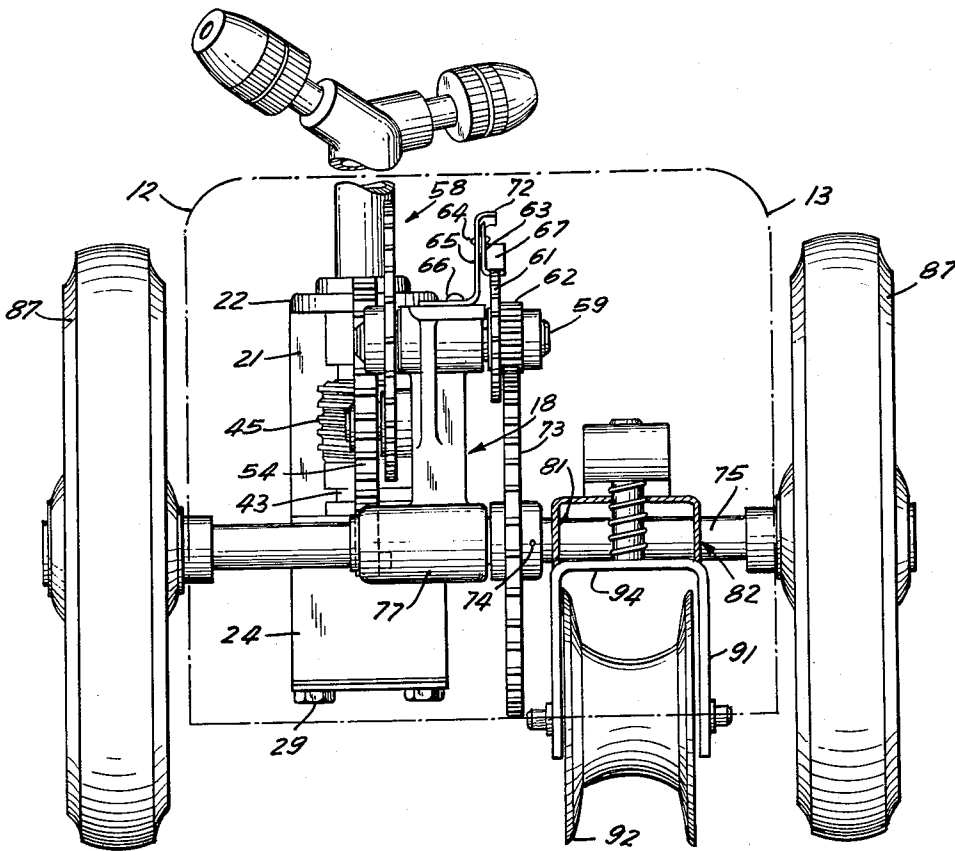
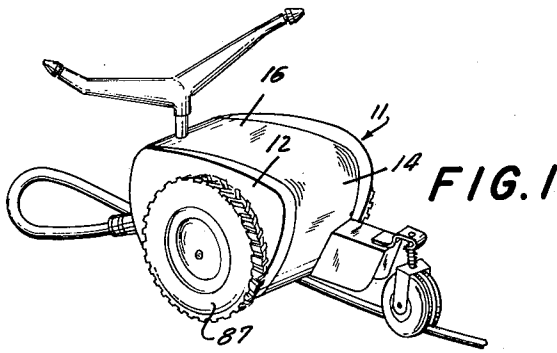

FIG. 2

INVENTOR.
JULES ROSENKRANZ

BY
Dean, Fairbank & Hild

ATTORNEYS

May 23, 1961

J. ROSENKRANZ

2,985,380

SELF-PROPELLED WATER SPRINKLER

Filed Nov. 14, 1958

3 Sheets-Sheet 2

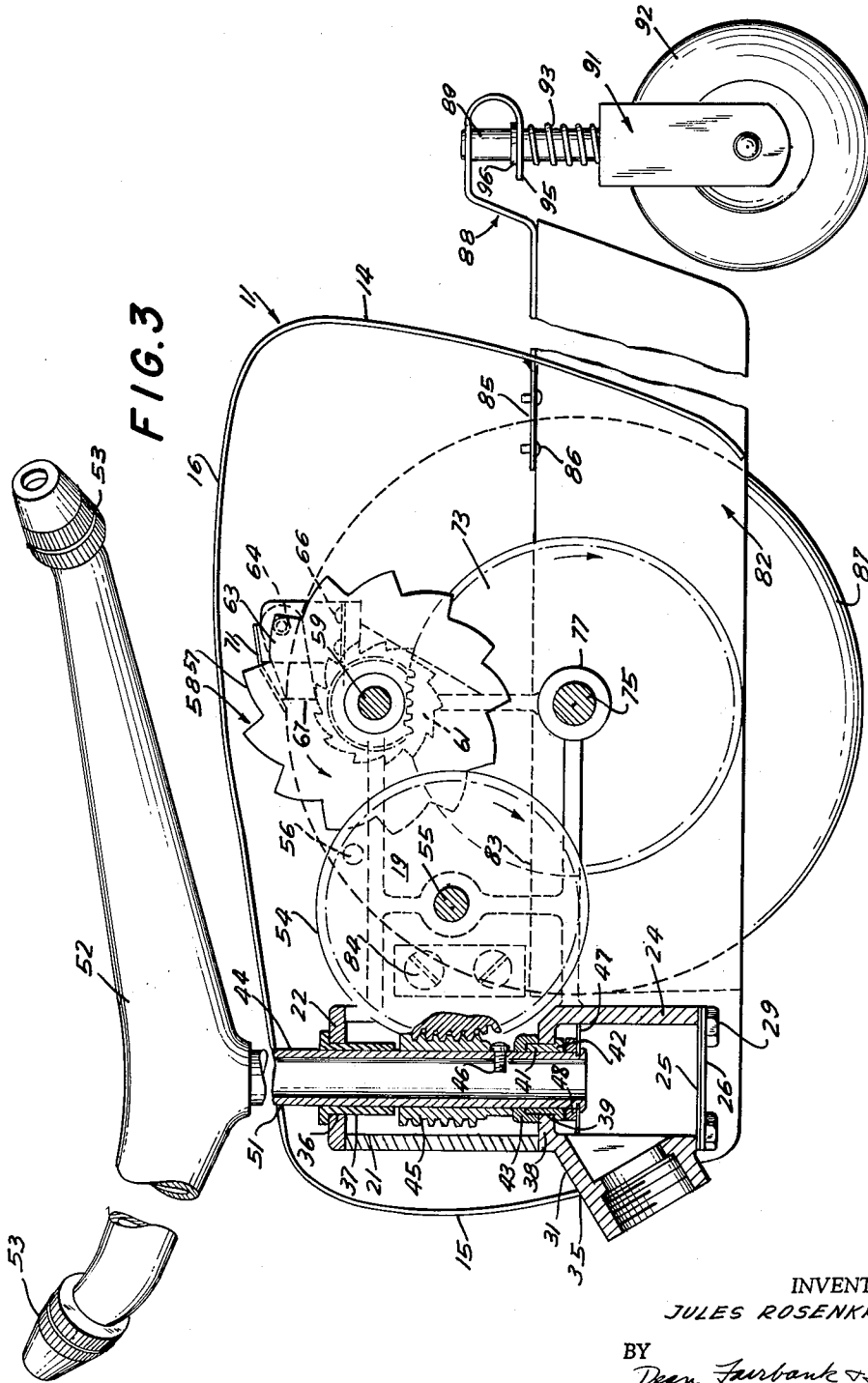

INVENTOR.
JULES ROSENKRANZ
BY
Dean Fairbank & Hirsch
ATTORNEYS

May 23, 1961

J. ROSENKRANZ

2,985,380

SELF-PROPELLED WATER SPRINKLER

Filed Nov. 14, 1958

3 Sheets-Sheet 3

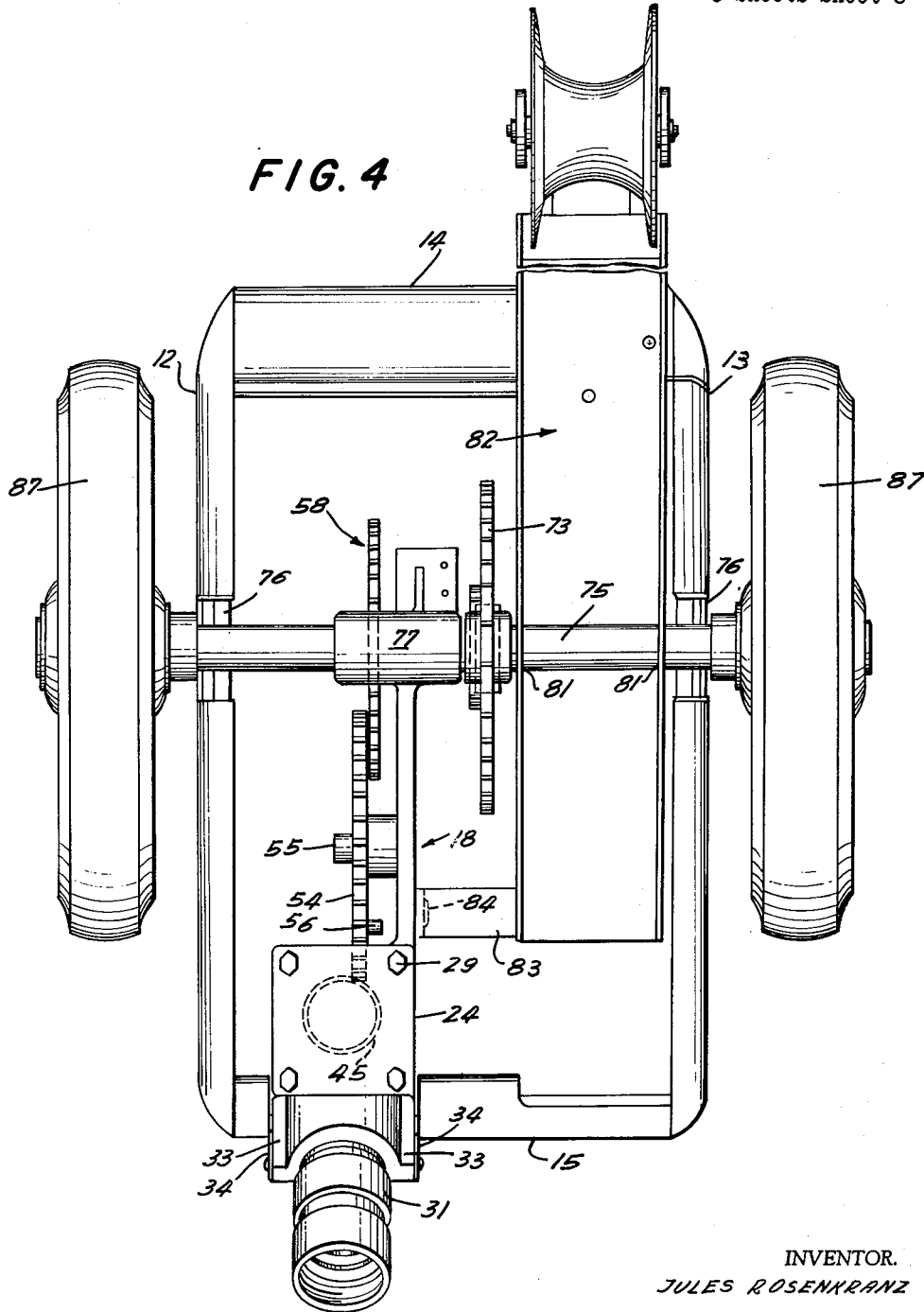

INVENTOR.
JULES ROSENKRANZ
BY
Dean, Fairbank & Hirsch
ATTORNEYS

1

2,985,380

SELF-PROPELLED WATER SPRINKLER

Jules Rosenkranz, New York, N.Y., assignor to Lafayette Brass Mfg. Co., Inc., a corporation of New York

Filed Nov. 14, 1958, Ser. No. 774,058

1 Claim. (Cl. 239—183)

This invention relates to the art of water sprinklers, more particularly of the self-propelled type.

It is among the objects of the invention to provide a water sprinkler of the above type that is neat, compact and has but few relatively simple parts that may readily be assembled at relatively low cost and is not likely to become deranged even with long use, which will dependably advance at relatively slow speed in only a forward direction along a guided path, solely under the action of water passing therethrough into the spray head thereof and will operate without jamming and require relatively few adjustments and may readily be lubricated.

According to the invention, these objects are accomplished by the arrangement and combination of elements hereinafter described, and more particularly recited in the claim.

In the accompanying drawings in which are shown one or more of various possible embodiments of the several features of the invention,

Fig. 1 is a perspective view of the unit,

Fig. 2 is a front view thereof with the casing broken away to expose the interior of the unit,

Fig. 3 is a longitudinal sectional view thereof, and

Fig. 4 is a bottom plan view of the unit.

Referring now to the drawings, the unit comprises a casing 11 having side walls 12 and 13, a front wall 14, a rear wall 15 and a top wall 16.

Positioned in the casing and extending longitudinally thereof from its rear wall 15 is a casting 18 which comprises a vertical, substantially rectangular plate 19, having a flange 21 at the end thereof adjacent the rear wall 15, said flange extending at right angles to the plate and having a top wall 22. Depending from the lower edge of the casting adjacent the flange 21 thereof is a substantially rectangular hollow block 24, the open bottom of which is normally closed by means of a rectangular gasket 25 over which a rectangular plate 26 is positioned, the gasket and the plate being secured to the block by means of screws 29. The rear of the block has a downwardly inclined nipple 31, preferably formed integral therewith, which is in communication with the interior of the block 24.

The nipple 31 is internally threaded at its outer end to receive a suitable connector to which a hose may be applied. The nipple 31, as shown in Fig. 4, has lateral wings 33 which may be secured to tongues 34 struck out from the recess 35 in the rear wall of the casing 11 through which the nipple 31 extends, thus securely retaining the casting 18 in position.

As shown in Fig. 3, the top wall 22 of the flange of the casting has an opening 36 in which is secured a bushing 37. The top wall 38 of the block 24 has an opening 39 axially aligned with the opening 36 in the top wall 22 of the flange. Positioned in said opening 39 is a sleeve 41, illustratively of neoprene, which defines a bushing, the lower end of the sleeve having an annular flange 42 positioned beneath the top wall 38 of the block 24. The upper end of the sleeve 41 extends above the

2

top wall 38 and is encompassed by the side wall of a cup-shaped spacer washer 43.

Extending through the bushing 41, the spacer washer 43 and the bushing 37 is a tube or pipe 44 which defines a shaft. Affixed to the portion of the shaft 44 between the cup-shaped washer 43 and the lower end of the bushing 37 is a worm 45, illustratively of neoprene, which is secured in place as by screw 46, the lower end of the worm being positioned adjacent the washer 43. The lower end of the shaft is outwardly turned to retain a washer 47 in position to prevent upward movement of the shaft 44 and also to retain a gasket 48 encompassing the shaft, positioned between said washer 47 and the flange end of the bushing 41.

The shaft 44 which is hollow, extends through an opening 51 in the top wall 16 of the casing 11 and is threaded at its upper end to receive a conventional double jet sprinkler head 52, which upon flow of water through the two jets 53 thereof, will rotate the shaft 44 and the worm 45.

The worm 45 meshes with a worm gear 54, also of neoprene, which is rotatably mounted on a stud shaft 55 affixed to the plate 19 of the casting 18 and extending laterally outward therefrom toward the side wall 12 of the casing 11. The gear 54 has a stud 56 extending laterally outward from the side thereof and preferably molded integrally therewith which is designed to engage the teeth 57 of a star wheel 58 mounted on one end of a shaft 59 extending laterally through the plate 19 and rotatably mounted with respect thereto.

The other end of the shaft 59 mounts a ratchet wheel 61 and a gear 62, said ratchet wheel and said gear being molded as an integral unit. Associated with the ratchet wheel 61 is a ratchet arm 63 which, as shown in Fig. 3, is pivotally mounted as at 64 at one end, to the upper end of the vertical leg of an L-shaped bracket 65 secured as by screws 66 to the upper edge of the casting 18. The ratchet arm 63 is bent at right angles at its free end 67 and adapted to engage the teeth of the ratchet wheel 61. The free end of the arm 63 is resiliently urged against the ratchet wheel by means of a leaf spring 71 affixed at one end to a lateral finger 72 formed rigidly with the vertical leg of the bracket 65, the free end of the leaf spring bearing against the upper edge of the pivoted arm 63 to urge the latter downwardly against the ratchet wheel.

The gear 62 which is secured to the shaft 59 meshes with a main drive gear 73, also of neoprene, which is secured as by set screw 74 to the axle 75 of the unit. As shown in Figs. 2 and 4, the axle extends transversely across the unit through notches 76 in its side walls 12 and 13. The axle is journaled in a sleeve or bushing 77 formed integral with the casting at its lower edge and extending at right angles thereto.

The axle 75 also extends through transversely aligned openings 81 in the side walls of an inverted U-shaped channel member 82 which extends parallel to the side wall of the casing 11. One end of the channel member has a supporting strip 83 secured thereto, the other end of the supporting strip having a right angle portion which is secured to the plate 19 as by screws 84. The forward end of the channel member 82 extends through a corresponding notch in the front wall 14 of the casing and is secured thereto by an inwardly bent tongue 85 secured to the top wall of the channel member by screws 86.

Each of the ends of the axle 75 mounts a wheel 87, illustratively with a rubber periphery and the top front end of the channel member mounts a bracket 88 reversely bent at its free end which rotatably supports a stud shaft 89 to the lower end of which a yoke 91 is secured, the legs of the latter straddling a roller 92 which is rotat-

ably mounted therebetween, said roller having a deep annular groove for the purpose hereinafter described. Desirably, a coil spring 93 encompasses the shaft 89 between the cross piece 94 of the yoke and the inturned leg 95 of the bracket so that the roller 92 is normally resiliently urged downwardly, the downward movement being restrained by a split ring 96 encompassing the shaft 89 and being positioned in an annular groove therein, said split ring abutting against the leg 95 of the bracket.

In the operation of the unit, to water a garden, for example, a hose is connected to the nipple 31 at the end of the casing. The hose is then curled so that it extends beneath the unit between the wheels 87 thereof, the roller 92 riding over such hose. When water under pressure is applied to the hose, as shown in Fig. 3, such water will flow through the nipple 31 into the block 24 and thence through the hollow tube 44 into the sprinkler head 52. The water will thereupon be ejected from the two jets 53 of the sprinkler head in substantially opposite directions to impart torque to the shaft to rotate the latter. Upon rotation of the shaft 44, the worm 45 thereon will also rotate to drive the worm gear 54, say in a clockwise direction, referring to Fig. 3. With each revolution of the worm gear 54, the stud 56 thereon will engage one of the teeth 57 of the star wheel 58, to rotate the latter a relatively short distance. It is apparent therefore, that many rotations of the worm gear 54 are required to effect a single rotation of the star wheel 58. In the illustrative embodiment, since there are thirteen teeth on the star wheel 58 it will require thirteen rotations of the worm gear for one full rotation of the star wheel and the shaft 59 on which it is mounted.

Rotation of the worm gear 54 in a clockwise direction will effect rotation of the star wheel 58 in a counterclockwise direction to rotate the ratchet wheel 61 and gear 62 also mounted on shaft 59 in corresponding direction. This in turn will rotate the main drive gear 73 in a clockwise direction to effect advance of the unit to the right from the position shown in Fig. 3 so that the roller 92 will ride along the hose to be guided thereby.

By reason of the ratchet arm 63, which is urged by leaf spring 71 against ratchet wheel 61, the ratchet wheel and hence the gear 62 can only rotate in a counterclockwise direction so that only forward movement of the wheels 87 carried by axle 75, which is driven by main gear, 73 can be effected.

With the equipment above described, by laying out the hose so that it is positioned adjacent the area to be sprinkled, the unit will be guided by the hose and as

the unit advances at relatively slow speed, complete and even watering is effected.

As many changes could be made in the above construction, and many apparently widely different embodiments of this invention could be made without departing from the scope of the claim, it is intended that all matter contained in the above description or shown in the accompanying drawings shall be interpreted as illustrative and not in a limiting sense.

A self-propelled water sprinkler comprising a casing having an axle extending transversely therethrough, a wheel mounted at each end of said axle, a roller positioned in front of said casing and supported thereby, a vertical drive shaft positioned in said casing and rising above the top of the latter, a spray head affixed to the top of said drive shaft and adapted to rotate the latter, said drive shaft having an inlet at its lower end, means to connect a source of water under pressure to said inlet to flow through said drive shaft into said spray head to rotate the latter, a drive gear affixed to said axle, a gear engaging said drive gear, a star wheel rigidly mounted with respect to said gear on the same axis thereof, a worm affixed to said drive shaft, a worm gear engaged by said worm for rotation by the latter, said worm gear carrying a stud adapted successively to engage the teeth of said star wheel to effect intermittent rotation of the latter to drive said axle upon rotation of said drive shaft, a ratchet wheel affixed to the shaft mounting said star wheel and said gear, a ratchet arm engaging said ratchet wheel and resilient means retaining said ratchet arm against said ratchet wheel to permit rotation of the latter in but a single direction.

References Cited in the file of this patent

UNITED STATES PATENTS

2,152,425	Wilson	Mar. 28, 1939
2,249,211	Johnson	July 15, 1941
2,540,224	Vasselli	Feb. 6, 1951
2,540,556	Salatin	Feb. 6, 1951
2,563,519	Egly et al.	Aug. 7, 1951
2,589,940	Hayek	Mar. 18, 1952
2,602,696	Salatin	July 8, 1952
2,683,056	Hilfinger	July 6, 1954
2,788,241	Jepson	Apr. 9, 1957
2,905,392	Keltner	Sept. 22, 1959

FOREIGN PATENTS

524,133	Canada	Apr. 24, 1956
---------	--------	---------------