

Oct. 13, 1931.

F. STURM

1,827,214

CARBURETOR FOR INTERNAL COMBUSTION ENGINES

Filed Dec. 10, 1927

Fig. 1.

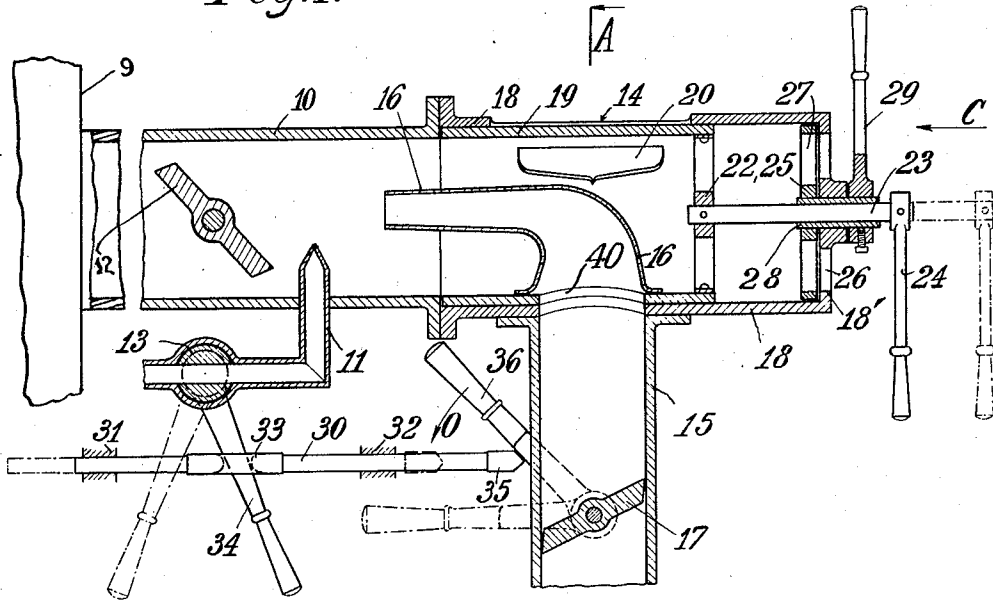
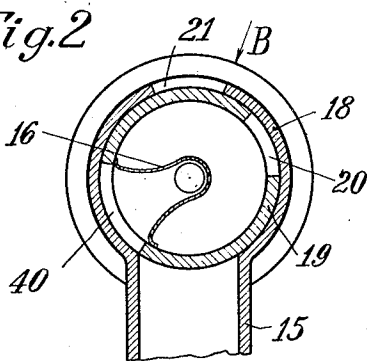

Fig. 2



A

Fig. 4.

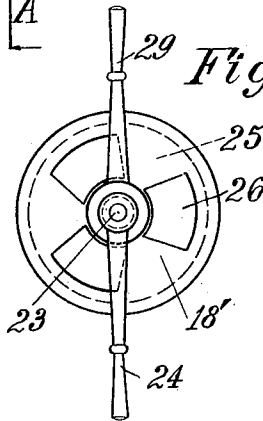
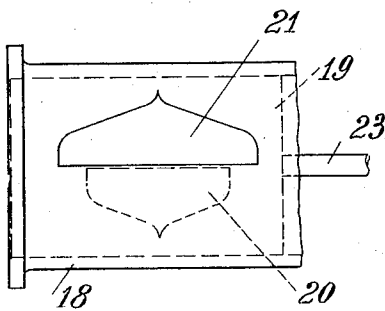

Fig. 3.



Inventor:

Fritz Sturm

by:

Attorney

UNITED STATES PATENT OFFICE

FRITZ STURM, OF FRIEDRICHSHAFEN, BODENSEE, GERMANY, ASSIGNOR TO LUFT-SCHIFFBAU ZEPPELIN GESELLSCHAFT MIT BESCHRANKTER HAFTUNG, OF FRIEDRICHSHAFEN, BODENSEE, GERMANY

CARBURETOR FOR INTERNAL COMBUSTION ENGINES

Application filed December 10, 1927, Serial No. 239,200, and in Germany December 14, 1926.

My invention relates to internal combustion engines and has special reference to the carburetor therefor and its air intake.

The primary object of my invention is to adapt an internal combustion engine having a carburetor for gasoline so as to be capable of also being fed with a gaseous mixture of a hydro-carbon gas with air, but alternately with one or the other. For this purpose I provide the air intake of the customary and ordinary carburetor with a special mixing chamber into which a pipe opens coming from the container of the fuel gas and which chamber also has a controlled aperture for the purpose of admitting air. This mixing chamber according to my invention is situated in front of the air intake of the carburetor usual with internal combustion engines. Thus the air flowing to the gasoline carburetor has to pass through the mixing chamber fixed before its air intake.

According to my invention in the mixing chamber the cross sections of the air intake and of the gas intake are controlled. I prefer to provide a combined regulating means for this purpose which for example may consist in a rotary slide valve. Gas intake and air intake may open into a surrounding casing and their openings may be governed by corresponding slots or ports in the slide valve. The shape of these ports has to be determined by experiment, and in accordance with the specific fuel gas used.

A further possibility of regulating the ratio of the amount of gas to the amount of air admitted is given by not only turning the rotary slide valve, but by also shifting it in its longitudinal direction.

It may be advisable to provide in addition thereto a second air intake also controlled in its cross section by which the gas and air mixture may again be altered if so desired in special cases. I prefer to provide this second air intake in such dimensions that its cross section when fully open suffices for the air ad-

mittance necessary for the ordinary gasoline carburetor situated between the mixing chamber and the intake manifold connecting to the cylinders of the engine.

All this arrangement according to my invention is made for the purpose of alternately feeding the motor with gasoline or with a fuel gas. This is of special importance with airship motors because according to the latest development mostly gaseous fuel is stored in an airship for driving its engines therewith, and only under special conditions and for certain purposes gasoline is fed to the motors, for which purpose a comparatively small amount of gasoline only is stored in the airship.

To make sure that only gasoline or gaseous fuel is fed to the engine I provide closing up elements both in the gasoline pipe leading to the ordinary carburetor and in the gas pipe leading to the mixing chamber situated ahead of the carburetor. These closing up elements may be operated independently from each other, but they may also be connected with each other in such manner that opening of one of them causes a locking of the other, or vice-versa.

Having given a general description of my invention I now want to point it out more in detail referring to the drawings which represent an example embodying my invention.

Fig. 1 is a diagrammatical longitudinal sectional view of an ordinary carburetor together with the mixing chamber and accessories. In this figure the piping for feeding the gasoline to the carburetor is open whereas the gas leading to the mixing chamber is shut off.

Fig. 2 is a cross section drawn on line A—A of Fig. 1 through the mixing chamber.

Fig. 3 is a top view of the mixing chamber seen in the direction of arrow B (Fig. 2).

Fig. 4 is an end view of the mixing chamber seen in the direction of arrow C (Fig. 1).

The carburetor that is connected to an engine 9 comprises tube 10 with nozzle 11 and

throttle valve 12. The gasoline pipe has the customary cock 13. In direct continuation to the carburetor tube 10 the mixing chamber 14 is situated. Into this mixing chamber 5 opens a pipe 15 leading from a gaseous fuel gas container (not shown in the drawings). A valve 17 serves for controlling the amount of gaseous fuel fed. The mixing chamber contains in its surrounding casing 10 a rotary slide valve 19 provided with an aperture 20 adapted to be moved in certain relation to an air inlet port 21 of the surrounding casing 18. A second aperture 40 registers with the gas intake tube 15. There 15 is a nozzle 16 provided inside of the mixing chamber and has its base secured to the valve 16 about the aperture 40. Gaseous fuel is forced through this nozzle into the surrounding air jacket for the purpose of insuring 20 a better mixture. The movement of the valve body 19 may be performed by turning it or by shifting it longitudinally or by both operations. Valve body 19 is provided with a spider 22 and a shaft 23, the latter extending 25 through the end wall 18' of the casing 18 and having the handle 24 fixed on it so that it is possible to rock the valve body 19 with its shaft or to shift it in longitudinal direction. In the example shown in the 30 drawings the slots or ports 20, 21 and 40 are shaped triangular or the like so that with their relative movement in the one or other direction a gradual enlargement or reduction of the air and gas intakes is attained.

35 Valve 25 provided in the end wall 18' of the casing 18 of the mixing chamber allows for additional air admittance. The end wall is perforated by openings 26 which registers with openings 27 in the valve. The 40 valve is fitted on the hollow shaft 28 and is operated by the handle 29.

A shifting rod 30 is guided in fixed bearings 31 and 32. This rod has an opening 33 adjacent one end for receiving the control 45 lever 34 of the gasoline valve and has its opposite end 35 extending towards the control lever 36 of the gas valve 17, so that in the position of the parts shown in the drawings i. e. if the gasoline valve 13 is open the 50 rod locks the control lever 36 and thereby prevents its movement in the direction of the arrow O. Consequently the gas throttle valve 17 must remain in closed position. Only when the gasoline valve 13 of the carburetor is in closed position, can the handle 55 36 be free to turn and thus open the gas valve 17.

This locking device in any well known manner may be so developed as to lock also 60 lever 34 in closed position, so long as lever 36 rests in open position.

I do not want to be limited to the details described or shown in the drawings as many 65 variations will occur to those skilled in the art.

What I claim is:

1. A carburetor for an internal combustion engine comprising a mixing chamber having an air inlet valve connected thereto, a connection for supplying liquid fuel to the mixing chamber, a connection for supplying gaseous fuel to the mixing chamber, valves in both of said connections, one of said valves being open while the other is closed, and means connecting the last-mentioned valves to provide for simultaneous operation thereof, either valve being progressively opened while the other valve is being progressively closed by the operation of said means. 70 75

2. A carburetor for an internal combustion engine comprising a tubular mixing chamber, a conduit for supplying liquid fuel to the mixing chamber, an air inlet valve rotatable with respect to the mixing chamber and slidable axially thereof, a conduit for supplying gaseous fuel to the mixing chamber, valves in both of said conduits, and the means connecting the last-mentioned valves to provide for simultaneous operation thereof. 80 85 90

3. In a carburetor for an internal combustion engine, a mixing chamber, a conduit for supplying liquid fuel to the mixing chamber, a conduit for supplying gaseous fuel to the mixing chamber, inter-connected valves in both of said conduits operated simultaneously to discontinue the supply of the one fuel while the other is being supplied, and an air inlet valve element including a continuation of the gaseous fuel conduit and controlling the supply of gaseous fuel and air. 95 100

4. In a carburetor for an internal combustion engine, a tubular mixing chamber, a conduit for supplying liquid fuel to the mixing chamber, a conduit for supplying gaseous fuel to the mixing chamber, a valve in each conduit, a connection between the valves to provide for concurrent operation thereof, and a tubular air inlet valve member rotatably mounted in the mixing chamber, including a continuation of the gaseous fuel conduit, said inlet valve member being slidable axially of the tubular member to vary the air and gaseous fuel inlets, together with the variation caused by the rotation thereof. 105 110 115

5. In a carburetor for an internal combustion engine, comprising a tubular mixing chamber, a conduit for supplying liquid fuel to the mixing chamber, a conduit for supplying gaseous fuel to the mixing chamber, inter-connected means for controlling the supply of fuel through both of the fuel conduits, a tubular air inlet valve member movable axially and rotatably in the mixing chamber, an actuating member connected axially of the air inlet valve member and extending from the mixing chamber, a second air inlet valve member mounted rotatably about the actuating member and operating means ex- 120 125 130

tending from the second air inlet valve member outside the mixing chamber.

6. In a carburetor for an internal combustion engine, a tubular mixing chamber, means for supplying fuel to the mixing chamber, a tubular air inlet valve member axially movable and rotatable in the mixing chamber, an actuating member connected axially to the air inlet valve member, a second air inlet valve member rotatably mounted upon the actuating member, the actuating member extending axially with a portion of the second air inlet valve member from the mixing chamber.

FRITZ STURM.

15

20

25

30

35

40

45