



INTERNATIONAL APPLICATION PUBLISHED UNDER THE PATENT COOPERATION TREATY (PCT)

<p>(51) International Patent Classification <sup>6</sup> : <b>B67D 5/40</b></p>	<p><b>A1</b></p>	<p>(11) International Publication Number: <b>WO 97/19016</b> (43) International Publication Date: 29 May 1997 (29.05.97)</p>
<p>(21) International Application Number: PCT/US96/16041 (22) International Filing Date: 7 October 1996 (07.10.96) (30) Priority Data: 08/560,467 17 November 1995 (17.11.95) US (71) Applicant: CONTICO INTERNATIONAL, INC. [US/US]; 1101 North Warson Road, St. Louis, MO 63132 (US). (72) Inventor: HILDEBRAND, George; 220 Waterford Crystal Drive, O'Fallon, MO 63366 (US). (74) Agents: ROLNICKI, Joseph, M. et al.; Howell &amp; Haferkamp, L.C., Suite 1400, 7733 Forsyth Boulevard, St. Louis, MO 63105-1817 (US).</p>		<p>(81) Designated States: AU, CA, JP, European patent (AT, BE, CH, DE, DK, ES, FI, FR, GB, GR, IE, IT, LU, MC, NL, PT, SE).  <b>Published</b> <i>With international search report.</i></p>

(54) Title: WIDE ERGONOMIC TRIGGER FOR A TRIGGER SPRAYER

(57) Abstract

A trigger sprayer apparatus (10) comprises a trigger (20) for manipulation by a user of the apparatus to dispense a spray, stream or foam of a liquid from the apparatus, the trigger (20) having finger engagement areas across the front surface of the trigger that increase in size as the trigger extends from its attachment to the trigger sprayer to a distal end of the trigger.

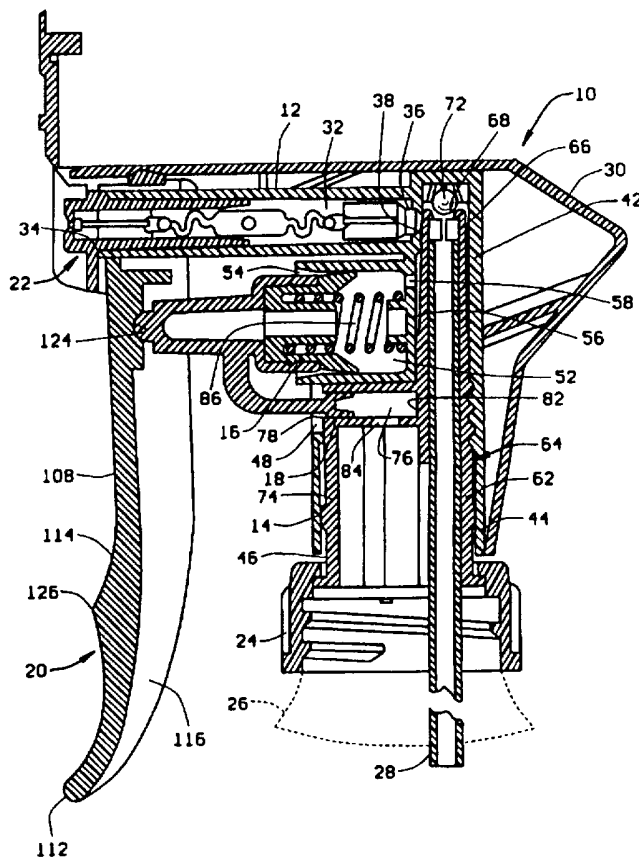

**FOR THE PURPOSES OF INFORMATION ONLY**

Codes used to identify States party to the PCT on the front pages of pamphlets publishing international applications under the PCT.

<b>AM</b>	Armenia	<b>GB</b>	United Kingdom	<b>MW</b>	Malawi
<b>AT</b>	Austria	<b>GE</b>	Georgia	<b>MX</b>	Mexico
<b>AU</b>	Australia	<b>GN</b>	Guinea	<b>NE</b>	Niger
<b>BB</b>	Barbados	<b>GR</b>	Greece	<b>NL</b>	Netherlands
<b>BE</b>	Belgium	<b>HU</b>	Hungary	<b>NO</b>	Norway
<b>BF</b>	Burkina Faso	<b>IE</b>	Ireland	<b>NZ</b>	New Zealand
<b>BG</b>	Bulgaria	<b>IT</b>	Italy	<b>PL</b>	Poland
<b>BJ</b>	Benin	<b>JP</b>	Japan	<b>PT</b>	Portugal
<b>BR</b>	Brazil	<b>KE</b>	Kenya	<b>RO</b>	Romania
<b>BY</b>	Belarus	<b>KG</b>	Kyrgystan	<b>RU</b>	Russian Federation
<b>CA</b>	Canada	<b>KP</b>	Democratic People's Republic of Korea	<b>SD</b>	Sudan
<b>CF</b>	Central African Republic	<b>KR</b>	Republic of Korea	<b>SE</b>	Sweden
<b>CG</b>	Congo	<b>KZ</b>	Kazakhstan	<b>SG</b>	Singapore
<b>CH</b>	Switzerland	<b>LI</b>	Liechtenstein	<b>SI</b>	Slovenia
<b>CI</b>	Côte d'Ivoire	<b>LR</b>	Liberia	<b>SK</b>	Slovakia
<b>CM</b>	Cameroon	<b>LK</b>	Sri Lanka	<b>SN</b>	Senegal
<b>CN</b>	China	<b>LT</b>	Lithuania	<b>SZ</b>	Swaziland
<b>CS</b>	Czechoslovakia	<b>LU</b>	Luxembourg	<b>TD</b>	Chad
<b>CZ</b>	Czech Republic	<b>LV</b>	Latvia	<b>TG</b>	Togo
<b>DE</b>	Germany	<b>MC</b>	Monaco	<b>TJ</b>	Tajikistan
<b>DK</b>	Denmark	<b>MD</b>	Republic of Moldova	<b>TT</b>	Trinidad and Tobago
<b>EE</b>	Estonia	<b>MG</b>	Madagascar	<b>UA</b>	Ukraine
<b>ES</b>	Spain	<b>ML</b>	Mali	<b>UG</b>	Uganda
<b>FI</b>	Finland	<b>MN</b>	Mongolia	<b>US</b>	United States of America
<b>FR</b>	France	<b>MR</b>	Mauritania	<b>UZ</b>	Uzbekistan
<b>GA</b>	Gabon			<b>VN</b>	Viet Nam

WIDE ERGONOMIC TRIGGER FOR A TRIGGER SPRAYER

This application is a continuation-in-part application of Design Patent Application Serial No. 29/043,775 filed September 12, 1995, and titled "Wide Ergonomic Trigger for a Trigger Sprayer".

5 Background of the Invention

(1) Field of Invention

The present application pertains to a trigger sprayer apparatus of the type comprising a trigger for manipulation by a user of the apparatus to dispense a  
10 spray, stream or foam of a liquid from the apparatus. In particular, the present invention pertains to an ergonomic trigger for such a trigger sprayer having finger engagement areas across the front surface of the trigger that increase in size as the trigger extends from  
15 its attachment to the trigger sprayer to a distal end of the trigger.

(2) Description of the Related Art

In prior art trigger sprayer apparatus employed in dispensing liquid from containers, the typical sprayer apparatus is comprised of a sprayer housing having a nozzle for dispensing liquid, a trigger mounted on the housing for pivoting movement relative thereto, a pump chamber formed in the housing, and a pump piston connected to the trigger and received in the pump chamber for reciprocating movement therein in response to pivoting movement of the trigger. The reciprocating movement of the pump piston alternately draws liquid from the container into the pump chamber, and then forces the liquid out of the pump chamber and through the nozzle in a spray, stream or foam pattern.

Trigger mechanisms of prior art sprayer assemblies are typically provided with a pair of laterally spaced flanges at their upper ends that are inserted around opposite lateral sides of a fluid dispensing nozzle attached to the sprayer housing of the apparatus. The flanges are also inserted between extensions of the sprayer housing positioned adjacent the opposite lateral sides of the fluid dispensing nozzle. The flanges are provided with pivot pins on their exterior surfaces that are received in sockets in the extensions of the sprayer housing. The insertion of the pivot pins in the sockets provides a pivoting connection of the trigger member to the sprayer housing.

The typical trigger of the prior art also includes a shank portion that extends longitudinally downwardly from the laterally spaced flanges at the upper end of the trigger to a distal end of the shank portion at the lower end of the trigger. The shank portion has a front surface that faces away from the sprayer housing of the sprayer apparatus, and a rear surface that is operatively engaged with the pump piston of the sprayer apparatus. The front surface of the shank serves as the finger engagement surface of the trigger. The fingers of a

user's hand engage across this surface when manipulating the trigger to operate the pump.

The lateral width of the shank position engagement surface is usually equal to or smaller than the lateral spacing between the flanges of the trigger mechanism for the entire longitudinal length of the shank portion. In some prior art trigger mechanisms, the lateral width is initially equal to the lateral spacing between the trigger flanges and decreases in size as the shank portion extends from the flanges to its distal end, thereby conserving the amount of plastic needed to mold the trigger mechanism.

Very often the principal consideration in the design of prior art trigger mechanisms is the costs involved in manufacturing the mechanisms. Prior art trigger mechanisms are frequently designed with configurations that are easy to mold from plastic and provide the required structural strength from the minimum amount of plastic needed to construct the trigger mechanism. These prior art trigger mechanisms have been found to be disadvantaged in that the designs do not take into consideration the comfort of the user's hand. The user's comfort is easily overlooked because the typical usage of a trigger sprayer apparatus requires reciprocating the pump piston only once or twice to initially prime the pump, and then once or twice more to dispense a desired amount of liquid from the sprayer apparatus. The comfort of the user's hand was likely not considered in the design of the engagement surfaces of prior art sprayer triggers because they were not seen as being manipulated a significant number of times by the user's hand in each use of the sprayer apparatus. However, it has since been recognized that the configurations of engagement surfaces of prior art trigger mechanisms cause discomfort to and fatigue the

fingers of a user's hand following any appreciable prolonged use of the sprayer apparatus.

Summary of the Invention

The present invention overcomes the aforesaid  
5 disadvantages typically associated with prior art trigger mechanisms by providing an improved trigger mechanism having an ergonomic engagement surface that reduces the discomfort and fatigue of the fingers of the user's hand during prolonged use of the sprayer apparatus. As in the  
10 prior art trigger mechanisms, the ergonomic trigger of the invention is provided with a pair of laterally spaced flanges at its upper end that are inserted around opposite lateral sides of a fluid dispensing nozzle attached to the sprayer housing of the sprayer apparatus.  
15 The flanges are also inserted between extensions of the sprayer housing positioned adjacent the opposite lateral sides of the nozzle. The flanges have pivot pins on their exterior surfaces that are received in sockets in the sprayer housing extensions, thereby mounting the  
20 trigger for pivoting movement relative to the sprayer housing.

The trigger is provided with a shank portion that extends downwardly from the pair of laterally spaced flanges to a distal end of the shank. The shank portion  
25 has opposite front and rear surfaces. Laterally spaced side edges separate the front and rear surfaces and extend the longitudinal length of the trigger shank between the flanges at the trigger upper end and the distal end of the trigger shank. The front surface of  
30 the trigger shank serves as the engagement surface for the fingers of a user's hand, and the rear surface of the trigger shank is operatively connected to the pump piston of the sprayer apparatus.

The improvement to the trigger mechanism of the  
35 invention is provided in the ergonomic configuration of the shank engagement surface. As the shank engagement

surface extends longitudinally downwardly from the flanges at the trigger upper end toward the shank distal end, the lateral width of the engagement surface increases. This configuration of the shank front surface provides engagement areas for each of the fingers of the user's hand that increase in size as the shank extends downwardly toward its distal end. The increased area of the engagement surface distributes the force exerted against the fingers of the user's hand during manipulation of the trigger over a greater area of the user's fingers, thereby appreciably decreasing the discomfort caused to the user's fingers during prolonged manipulation of the trigger. Furthermore, by the engagement surface configurations distributing the force of trigger manipulation over a greater area of the user's fingers, the fatigue caused to the user's hand from prolonged manipulation of the trigger is substantially reduced.

#### Brief Description of the Drawing Figures

Further objects and features of the present invention are revealed in the following detailed description of the preferred embodiment of the invention and in the drawing figures wherein:

Figure 1 is a side elevation view, in section, of a trigger sprayer apparatus with the trigger of the invention attached;

Figure 2 is a front elevation view of the trigger sprayer apparatus of Figure 1;

Figure 3 is a partial view, in section, of the trigger member taken along the line 3-3 of Figure 1;

Figure 4 is a partial view, in section, of the trigger member taken along the line 4-4 of Figure 3;

Figure 5 is a perspective view of the trigger mechanism of the present invention removed from the sprayer;

Figure 6 is a top plan view of the trigger;

Figure 7 is a rear elevation view of the trigger;  
Figure 8 is a left side elevation view of the  
trigger;

Figure 9 is a front elevation view of the trigger;  
5 and

Figure 10 is a bottom plan view of the trigger.

#### Description of the Preferred Embodiment

The ergonomic trigger of the present invention is  
employed on a trigger sprayer apparatus 10 of the type  
10 disclosed in U.S. Patent No. 5,344,053. However, it  
should be understood that the ergonomic trigger of the  
invention may be employed with various different types of  
manually operated trigger sprayer apparatus and various  
different types of manually operated apparatus employing  
15 a trigger. Although the trigger of the invention is  
described as being employed with one particular type of  
trigger sprayer apparatus, it should be understood that  
this explanation of the trigger of the invention is  
illustrative only and should not be interpreted as  
20 limiting the trigger for use with only one particular  
type of apparatus.

The ergonomic trigger of the present invention is  
shown in Figures 1 and 2 employed on a trigger sprayer  
apparatus 10 generally comprised of a sprayer housing 12,  
25 a vent housing 14, a pump piston 16 and interconnected  
vent piston 18, the trigger member 20 of the invention, a  
nozzle assembly 22, an internally threaded connector 24  
that connects the sprayer apparatus 10 to a fluid  
container 26, and a fluid supply tube 28 that extends  
30 from the sprayer apparatus 10 down into the interior  
volume of the container 26. As is commonly employed in  
trigger sprayer apparatus, an ornamental shroud 30 covers  
over the sprayer housing 12 and vent housing 14. Several  
component parts of the trigger sprayer apparatus 10  
35 listed above are conventional and will not be described  
in detail for simplicity, with the detailed descriptions



being directed to the improvements of the trigger member 20 of the invention.

The sprayer housing 12 is molded of a plastic type material and includes several separate interior chambers 5 connected in communication with each other. Positioned toward the top of the sprayer housing 12 is a fluid discharge channel 32. The channel 32 has a cylindrical interior surface with an opening 32 at its forward end, or left hand end as viewed in Figure 1, for receiving the 10 nozzle assembly 22. An end wall 36 closes off the opposite right hand end of the channel 32 and a valve seat 38 is formed at the center of the end wall. The valve seat 38 seats a valve head of a fluid spinner assembly.

15 The valve seat 38 communicates the interior of the discharge channel 32 with the interior of a hollow fluid supply column 42 of the sprayer housing 12. The fluid supply column 42 extends vertically downwardly from the top of the sprayer housing 12 along the rear of the 20 housing to a cylindrical vent housing chamber 44 provided at the bottom of the sprayer housing. An opening 46 at the bottom of the vent housing chamber 44 receives the vent housing 14 of the sprayer apparatus. An additional opening 48 is provided through a forward portion of the 25 vent housing chamber sidewall at the top of the vent housing chamber to accommodate the vent piston 18.

A cylindrical pump chamber 52 is formed in the sprayer housing 12 between the fluid discharge channel 32 and the vent housing chamber 44. The pump chamber 52 is 30 positioned just forward of the fluid supply column 42. The pump chamber 52 has an opening 54 at its forward end through which the pump piston 16 extends. An end wall 56 opposite the opening 54 closes off the rearward end of the pump chamber. A fluid channel 58 extends through the 35 pump housing end wall 56 and communicates the interior

volume of the pump chamber with the interior of the fluid supply column 42 at the rear of the sprayer housing 12.

The vent housing 14 has a vertically extending fluid conducting column 62 that is inserted into the interior of the fluid supply column 42 of the sprayer housing 12. The circumference of the vent housing column 62 at the upper end of the column is reduced to provide a fluid conducting channel 66 between the exterior of the vent housing column 62 and the interior of the sprayer housing column 42. The channel 66 communicates the pump chamber fluid channel 58 with the fluid discharge channel 32.

A check valve seat 68 is formed at the top end of the vent housing column 62 and a ball check valve 72 is provided on the valve seat. The check valve 72 controls the direction of liquid flow through the vent housing column, permitting liquid to flow out of the vent housing column 62 through the check valve seat 68, and preventing the flow of liquid back through the vent housing column through the check valve seat. The supply dip tube 28 is secured in the interior of the vent housing column 62 and extends downwardly from the vent housing column into the interior of the fluid container 26 connected to the sprayer apparatus.

A base 74 of the vent housing is formed integrally with the vent housing column 62. A cylindrical vent chamber 76 is formed extending transversely into the top of the vent housing base 74. The vent chamber 76 has an opened forward end 78 and a closed rearward end 82. The vent chamber opening 78 at the forward end, or left hand end as viewed in Figure 1, is aligned with the vent chamber opening 48 of the sprayer housing 12. A vent opening 84 passes through the bottom of the vent chamber sidewall. The opening 84 communicates the interior of the vent chamber with the interior of the vent housing

base and also the interior of the fluid container 26 connected to the sprayer apparatus.

The trigger member 20 of the invention is operated in the same manner as conventional triggers. The trigger member is engaged by the fingers of a user's hand to pivot the trigger member relative to the sprayer housing 12 and thereby pump fluid from the sprayer by reciprocation of the pump and vent pistons 16, 18 in their respective chambers. A coiled spring 86 in the pump chamber 52 returns the pump and vent pistons 16, 18 and the trigger member 20 to their at rest positions shown in Figure 1. The operation of the pump piston 16 in dispensing liquid from the apparatus is conventional.

The upper end 92, or proximal end, of the trigger member 20 has a pair of laterally spaced flanges 94, 96 formed thereon. The flanges extend upwardly around the opposite lateral sides of the sprayer housing fluid discharge channel 32. The lateral spacing between the flanges provides ample clearance between the mutually opposed interior surfaces of the flanges and the opposite lateral sides of the fluid discharge channel 32 and nozzle assembly 22. Each of the flanges 94, 96 has a pivot post or pin 98, 102 formed on its exterior surface. The pivot pins are formed coaxially with each other and at a rearward corner of the flanges as seen in Figure 4. Each of the pivot pins 98, 102 engages in a socket formed in the extensions 104, 106 of the sprayer housing 12 projecting over the opposite exterior surfaces of the flanges 94, 96. The engagement of the pivot pins 98, 102 in the sockets of the sprayer housing extensions 104, 106 provides the pivoting connection of the trigger member 20 to the sprayer housing.

The extensions 104, 106 of the sprayer housing are formed of the plastic material employed in constructing the sprayer housing and therefore have a resiliency. This resiliency permits the extensions to be deformed

away from each other while inserting the trigger member flanges 94, 96 between the extensions and around the fluid discharge channel 32 of the sprayer housing. When the trigger member is positioned relative to the sprayer housing extensions 104, 106 so that the pivot pins 98, 102 are positioned in the sockets of the extensions, the resiliency of the sprayer housing extensions 104, 106 causes the extensions to return to their at rest configuration shown in Figure 3 and retain the trigger member in its pivoting connection to the sprayer housing.

The trigger member has a longitudinally elongated shank portion 108 that extends downwardly from the pair of laterally spaced flanges 94, 96 to a distal end 112 of the shank. The shank portion 108 has opposite front 114 and rear 116 surfaces. Laterally spaced side edges 118, 122 extend downwardly along the longitudinal length of the shank from the flanges 94, 96 at the trigger upper end to the distal end 112 of the shank. The laterally spaced side edges 118, 122 extend between and separate the front and rear surfaces 114, 116 of the shank.

The shank rear surface 116 is provided with a journal recess 124 that engages with the piston 16 of the sprayer and provides the operative connection between the trigger member and the piston. This operative engagement provided by the journal recess 124 is only one type of possible mechanical connection between the trigger member 20 and the pump piston 16. It should be understood that various different types of operative connections may be provided between the trigger member 20 of the invention and the pump piston of the particular trigger sprayer apparatus with which the trigger member of the invention is used. Therefore, although the journal recess 124 is shown as the type of operative connection employed in this particular illustrative embodiment, various different types of mechanical connections may be employed

on the trigger member 20 of the invention connecting it to a pump mechanism.

The front surface 14 of the trigger shank serves as the engagement surface for the fingers of a user's hand operating the trigger sprayer apparatus. The improvement to the trigger mechanism 20 of the invention is provided in the ergonomic configuration of the shank front engagement surface 114. The front engagement surface is comprised of a plurality of engagement areas that are configured to engage with the individual fingers of the user's hand. The trigger shown has two engagement areas shown separated by a crest 126 that extends laterally across the trigger and separates the engagement areas. The crest comfortably fits between the fingers of a user's hand and prevents the user's fingers from slipping downwardly off the trigger during use. Although one crest is shown, two may be employed separating three engagement areas on the trigger. The engagement areas are spacially arranged over the front surface and increase in size as the shank engagement surface 114 extends longitudinally downwardly from the flanges at the trigger upper end toward the shank distal end. As the shank extends downwardly from its upper end toward its bottom end, the lateral width of the engagement surface 114 between the side edges 118, 122 also increases. As best seen in Figure 2, the lateral width of the shank is smallest at the top of the shank where it merges into the pair of laterally spaced flanges 94, 96. As the engagement surface 114 extends downwardly from the flanges, its lateral width gradually increases as it approaches the shank distal end 112. Adjacent to the shank distal end 112 the opposite lateral side edges 118, 122 begin to curve toward each other and meet at the shank distal end.

The increased area of the shank engagement surface 114 distributes the force exerted against the fingers of

the user's hand during manipulation of the trigger over a greater area of the user's fingers, thereby appreciably decreasing the discomfort caused to the user's fingers during prolonged manipulation of the trigger. By the  
5 engagement surface configurations distributing the force of trigger manipulation over a greater area of the user's fingers, the fatigue caused to the user's hand from prolonged manipulation of the trigger is substantially reduced.

10           While the present invention has been described by reference to a specific embodiment, it should be understood that modifications and variations of the invention may be constructed without departing from the scope of the invention defined in the following claims.

What is Claimed

1. A trigger for a trigger operated pump apparatus, the trigger comprising:

a shank having opposite top and bottom ends and opposite front and rear surfaces, a section of the rear surface being configured for engaging with a pump apparatus and the front surface being configured for engagement with at least one finger of a user's hand, the front surface having at least two finger engagement areas, the finger engagement area adjacent the shank top end being smaller than the finger engagement area adjacent the shank bottom end.

2. The trigger of Claim 1, wherein:

the shank has a longitudinal length between its top and bottom ends and the shank has a first lateral width across the shank front surface adjacent the shank top end and a second lateral width across the shank front surface adjacent the shank bottom end, the first lateral width being smaller than the second lateral width.

3. The trigger of Claim 2, wherein:

the shank has a connector at its top end configured for mounting the trigger to the pump apparatus for relative movement of the trigger to the pump apparatus, and the first and second lateral widths of the shank front surface are spaced longitudinally from the connector.

4. The trigger of Claim 1, wherein:

the shank front surface has a plurality of finger engagement areas sequentially arranged on the front surfaces between the shank top and bottom ends, and the engagement areas increase in size from the top to the bottom of the shank.

5. The trigger of Claim 1, wherein:

the shank has opposite side edges between the front and rear surfaces of the shank, the shank front surface has a plurality of widths between the side edges,

5 and the widths increase in size as the shank front surface extends from the top to the bottom of the shank.

6. The trigger of Claim 1, wherein:

the shank has opposite side edges between the front and rear surfaces of the shank, and the shank front surface has a convexed configuration between the side  
5 edges.

7. The trigger of Claim 3, wherein:

the connector is configured for mounting the trigger to the pump apparatus for movement of the pump apparatus between fluid charge and fluid discharge  
5 positions of the pump apparatus on relative manual movement of the trigger relative to the pump apparatus.

8. The trigger of Claim 1, wherein:

the section of the shank rear surface is configured for engaging with the pump apparatus to cause movement of the pump apparatus between fluid charge and  
5 fluid discharge positions of the pump apparatus in response to manual movement of the trigger relative to the pump apparatus.

9. A trigger for a trigger operated pump, the trigger comprising:

a shank with longitudinally opposite top and bottom ends, the top end having a connector configured  
5 for mounting the trigger to a pump apparatus for relative movement of the trigger to the pump apparatus, and the shank having a lateral width that is larger adjacent the shank bottom end than the lateral width adjacent the shank top end.

10. The trigger of Claim 9, wherein:

the connector is configured to mount the trigger to the pump apparatus for relative movement of the trigger toward and away from the pump apparatus.

11. The trigger of Claim 10, wherein:

the shank has opposite front and rear surfaces, and a section of the rear surface is configured for



engagement with the pump apparatus to cause movement of  
5 the pump apparatus between discharge and charge positions  
in response to movement of the trigger toward and away  
from the pump apparatus, respectively.

12. The trigger of Claim 9, wherein:

the lateral width of the shank increases as the  
shank extends from the connector toward the shank bottom  
end.

13. The trigger of Claim 9, wherein:

the shank has a front surface having a plurality  
of finger engagement areas spaced longitudinally over the  
front surface between the shank top and bottom ends, and  
5 at least one finger engagement area adjacent the shank  
bottom end is larger than at least one finger engagement  
area adjacent the shank top end.

14. The trigger of Claim 9, wherein:

the shank has a front surface having a plurality  
of finger engagement areas spaced longitudinally over the  
front surface between the shank top and bottom ends, and  
5 the finger engagement areas progressively increase in  
size from the shank top end toward the shank bottom end.

15. The trigger of Claim 9, wherein:

the shank has opposite front and rear surfaces and  
laterally opposite side edges that extend between the top  
and bottom ends of the shank and separate the front and  
5 rear surfaces, and a lateral width between the side edges  
increases along at least a portion of the shank front  
surface as the shank extends from adjacent the top of the  
shank toward the bottom of the shank.

16. The trigger of Claim 15, wherein:

at least a portion of the shank front surface has  
a convexed configuration between the side edges.

17. A trigger for a fluid dispenser having a  
housing containing a manually operated fluid dispensing  
pump, the trigger comprising:

a shank having opposite top and bottom ends,  
5 opposite side edges, and opposite front and rear surfaces  
extending between the top and bottom ends and the side  
edges;

a connector at the top end of the shank, the  
connector being configured for mounting the trigger on  
10 the fluid dispenser housing for movement of the trigger  
relative to the fluid dispenser housing; and,

the shank front surface having a width between the  
shank side edges that increases as the shank extends from  
adjacent its top end toward its bottom end.

18. The trigger of Claim 17, wherein:

the shank has a plurality of finger engagement  
areas on the front surface arranged longitudinally  
between the shank top and bottom ends, and at least two  
5 of the finger engagement areas increase in size as the  
shank extends from its top and toward its bottom end.

19. The trigger of Claim 17, wherein:

a section of the shank rear surface is configured  
for engaging with the pump to cause movement of the pump  
between fluid charge and fluid discharge positions of the  
5 pump in response to manual movement of the trigger  
relative to the fluid dispenser housing.

20. The trigger of Claim 17, wherein:

at least a portion of the shank front surface has  
a convexed configuration between the side edges.

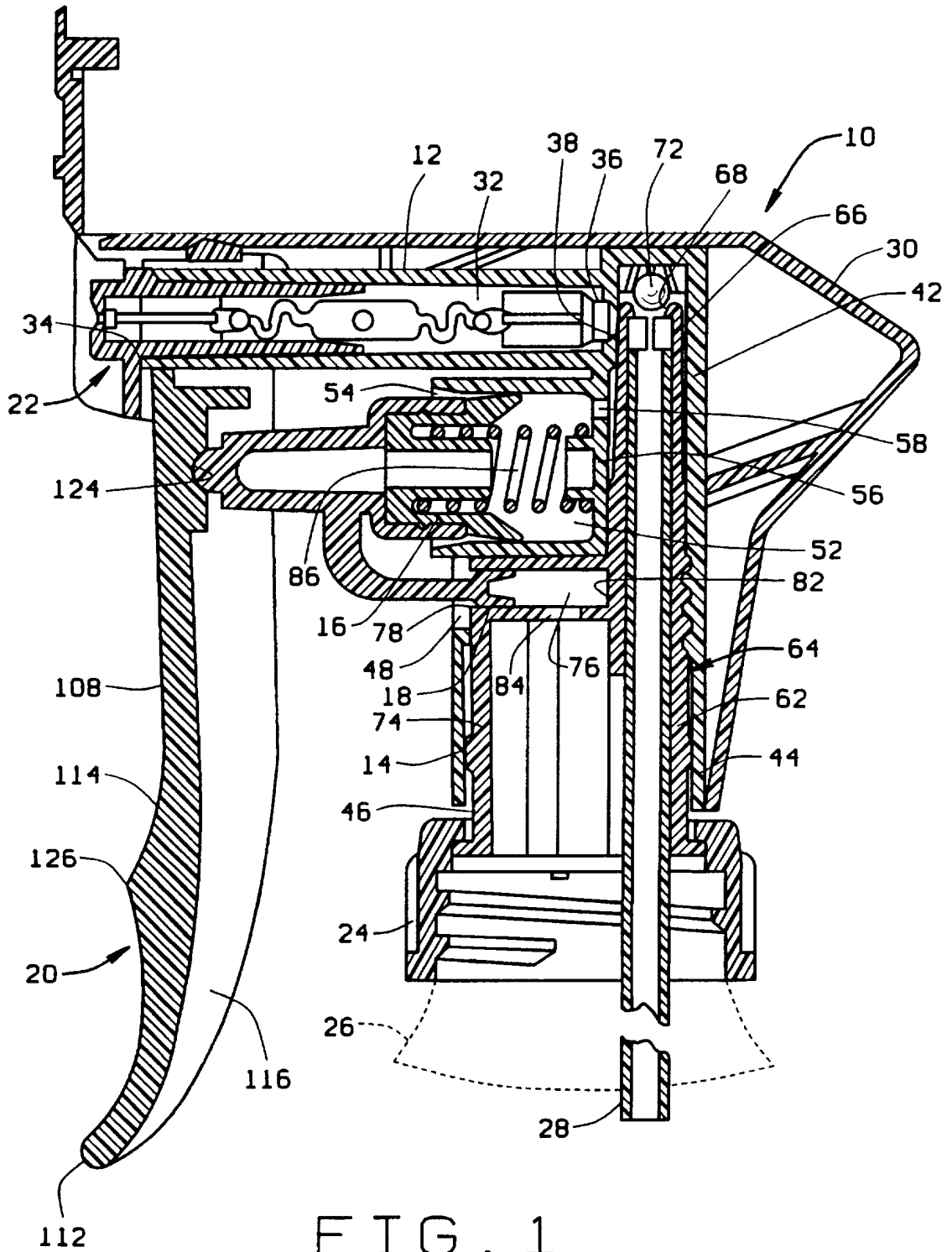

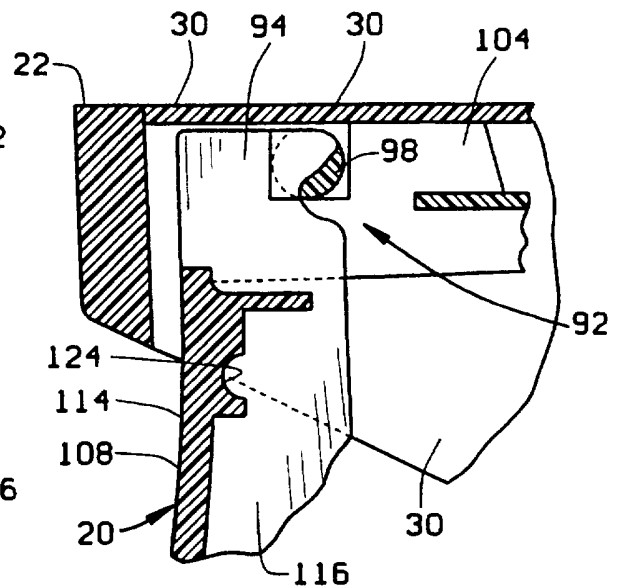
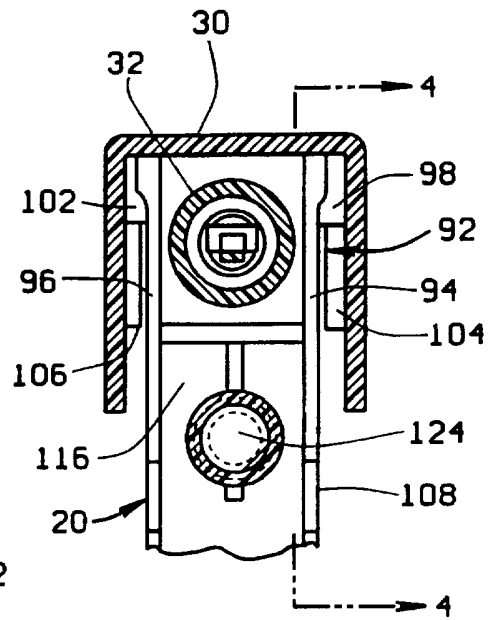
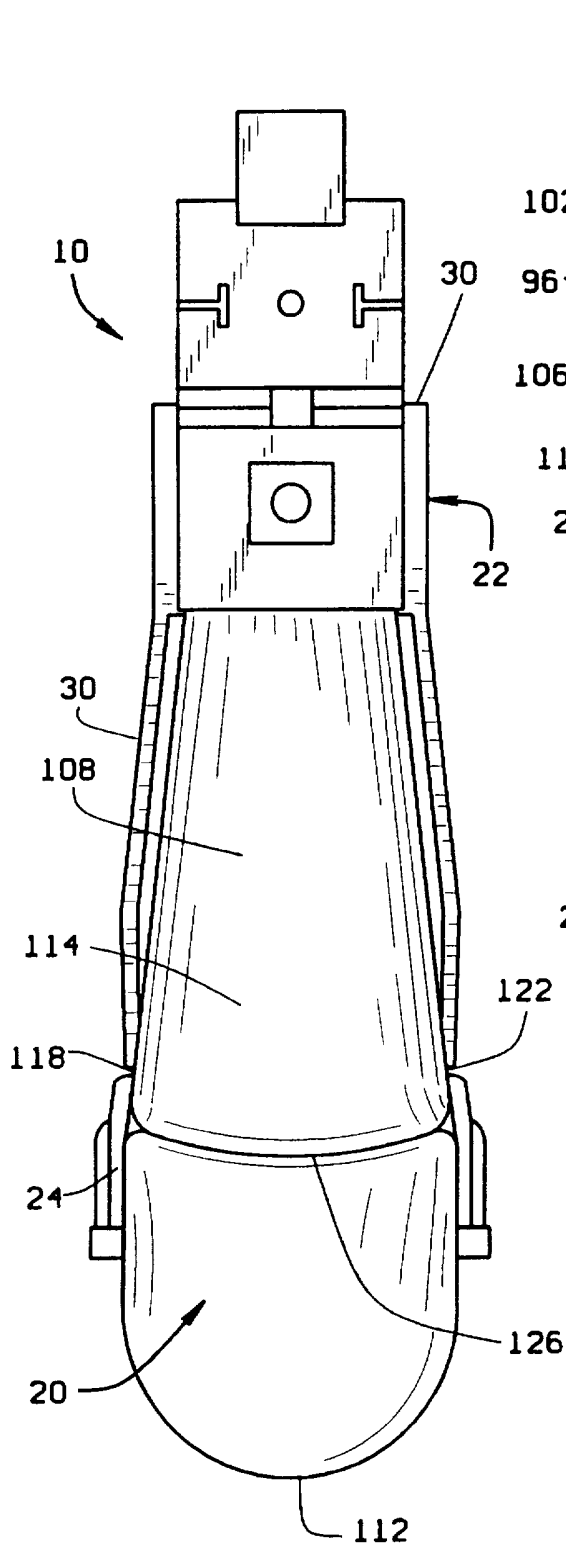

3/4

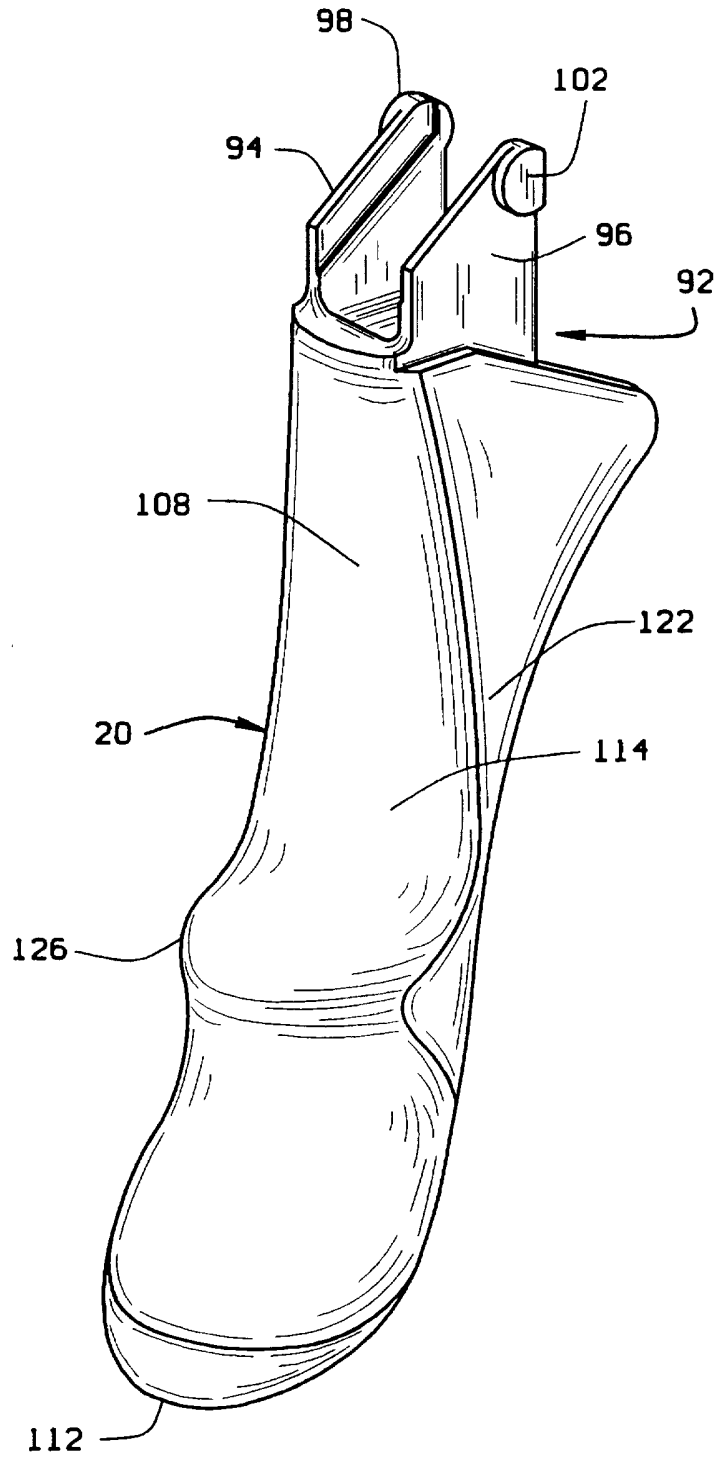

FIG. 5

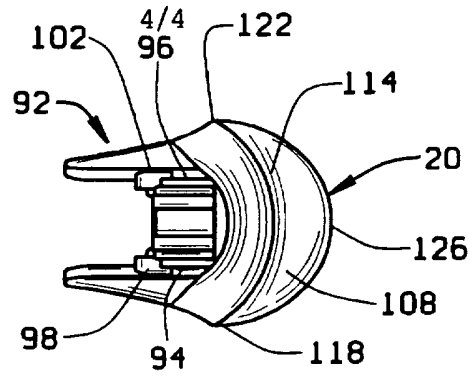

FIG. 6

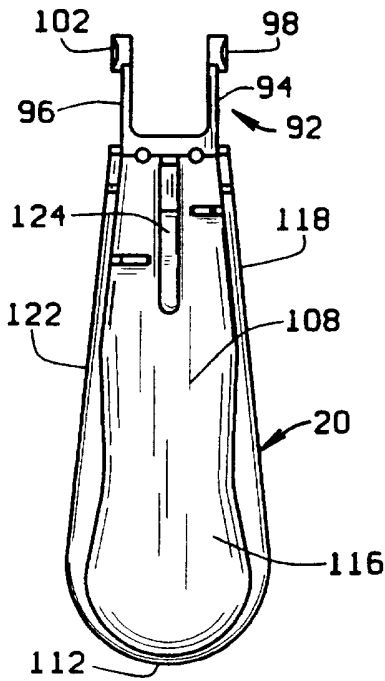

FIG. 7

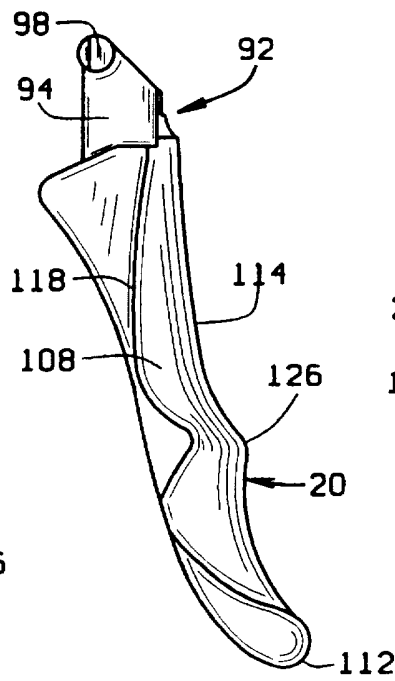

FIG. 8

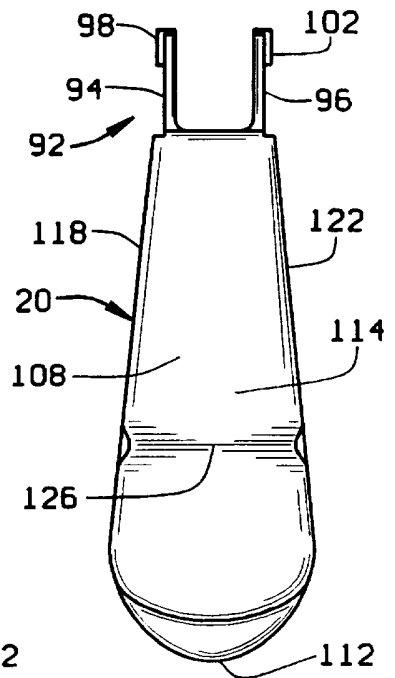

FIG. 9

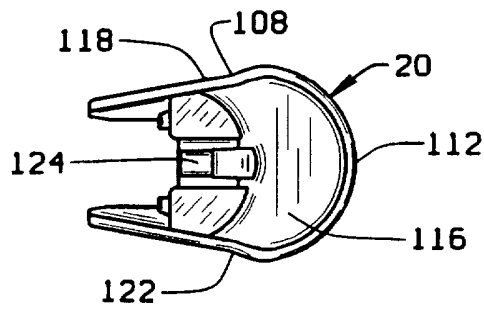

FIG. 10

INTERNATIONAL SEARCH REPORT

International application No.  
PCT/US96/16041

**A. CLASSIFICATION OF SUBJECT MATTER**

IPC(6) :B67D 5/40  
US CL :222/383.1, 474

According to International Patent Classification (IPC) or to both national classification and IPC

**B. FIELDS SEARCHED**

Minimum documentation searched (classification system followed by classification symbols)

U.S. : 222/383.1, 474

Documentation searched other than minimum documentation to the extent that such documents are included in the fields searched

Electronic data base consulted during the international search (name of data base and, where practicable, search terms used)

**C. DOCUMENTS CONSIDERED TO BE RELEVANT**

Category*	Citation of document, with indication, where appropriate, of the relevant passages	Relevant to claim No.
A	US, A, 5,172,836(Warner) 22 December 1992	
A	US, A, 5,318,492 (Quinn) 07 June 1994	
A	US, A, 5,507,437 (Foster et al.) 16 April 1996	
A	US, A, 5,332,159 (Grime et al.) 26 July 1994	
A	US, A, 4,826,052 (Micallef) 02 May 1989	
A	US, A, 3,112,849 (Wallace) 03 December 1963	
A	US, A, 3,209,949 (Gurtler) 05 October 1965	

Further documents are listed in the continuation of Box C.  See patent family annex.

* Special categories of cited documents:	*T	later document published after the international filing date or priority date and not in conflict with the application but cited to understand the principle or theory underlying the invention
*A* document defining the general state of the art which is not considered to be of particular relevance	*X*	document of particular relevance; the claimed invention cannot be considered novel or cannot be considered to involve an inventive step when the document is taken alone
*E* earlier document published on or after the international filing date	*Y*	document of particular relevance; the claimed invention cannot be considered to involve an inventive step when the document is combined with one or more other such documents, such combination being obvious to a person skilled in the art
*L* document which may throw doubts on priority claim(s) or which is cited to establish the publication date of another citation or other special reason (as specified)	*G*	document member of the same patent family
*O* document referring to an oral disclosure, use, exhibition or other means		
*P* document published prior to the international filing date but later than the priority date claimed		

Date of the actual completion of the international search

20 NOVEMBER 1996

Date of mailing of the international search report

20 DEC 1996

Name and mailing address of the ISA/US  
Commissioner of Patents and Trademarks  
Box PCT  
Washington, D.C. 20231

Authorized officer *H. L. Huson*  
GREGORY L. HUSON

Facsimile No. (703) 305-3230

Telephone No. (703) 308-1113