

(No Model.)

3 Sheets—Sheet 3.

H. I. SCHANCK.

MEANS FOR INCREASING CRANK THROW OF STEAM ENGINES.

No. 526,584.

Patented Sept. 25, 1894.

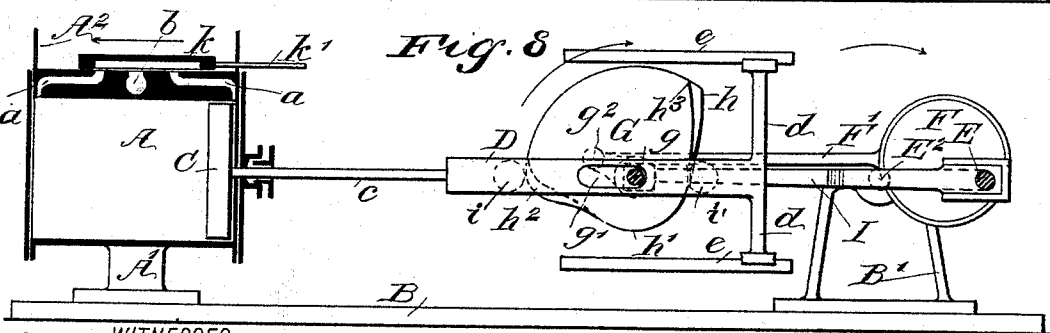
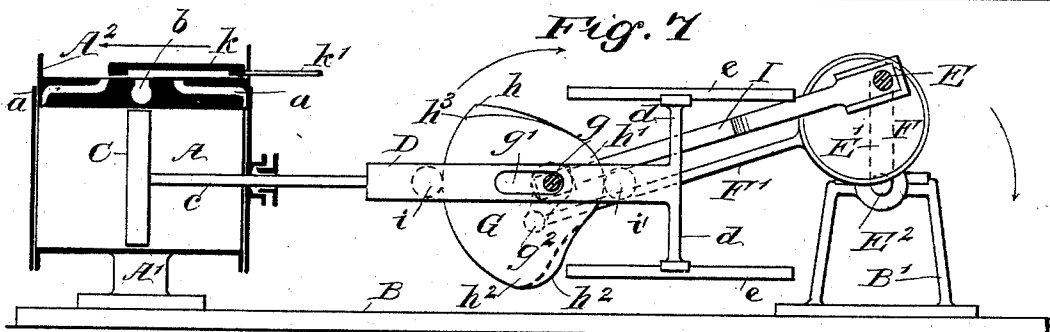
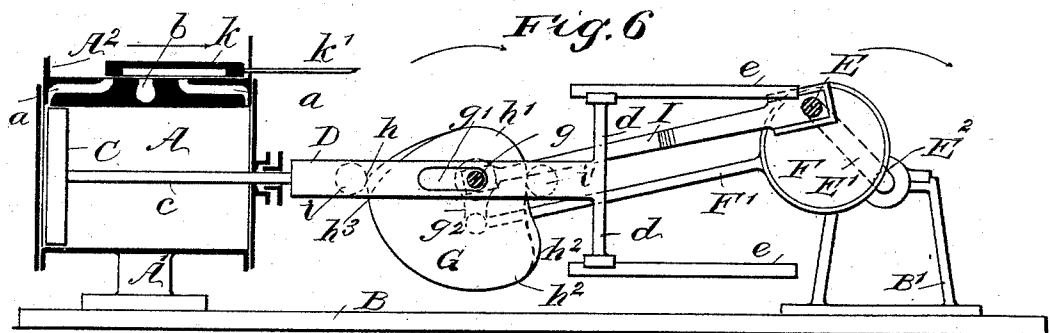
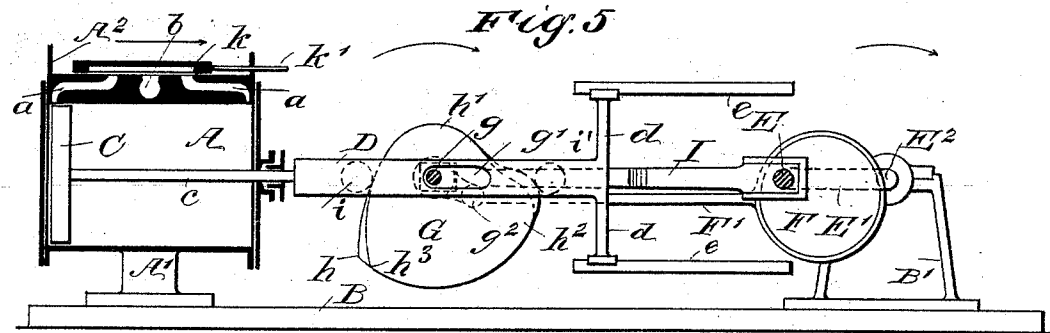

WITNESSES:
J. a. Berghman
C. Sedgwick

INVENTOR
H. I. Schanck
BY Munn & Co.

ATTORNEYS.

UNITED STATES PATENT OFFICE.

HENRY I. SCHANCK, OF HOLMDEL, NEW JERSEY.

MEANS FOR INCREASING CRANK-THROW OF STEAM-ENGINES.

SPECIFICATION forming part of Letters Patent No. 526,584, dated September 25, 1894.

Application filed November 9, 1893. Serial No. 490,427. (No model.)

To all whom it may concern:

Be it known that I, HENRY I. SCHANCK, of Holmdel, in the county of Monmouth and State of New Jersey, have invented a new and useful Improved Means for Increasing the Crank-Throw of Steam-Engines, of which the following is a full, clear, and exact description.

My invention relates to improvements in steam engines of both the horizontal and upright style, and more particularly to those of the high pressure quick speed type, and has for its objects to provide a steam engine of the type mentioned, with improved means for increasing the crank throw of the engine, and thereby conduce to increased efficiency for the improved steam engine, as compared with those of ordinary construction.

To these ends my invention consists in the construction and combination of parts, as is hereinafter described and claimed.

Reference is to be had to the accompanying drawings, forming a part of this specification, in which similar letters of reference indicate corresponding parts in all the figures.

Figure 1 is a plan view of the improved steam engine. Fig. 2 is a side view, partly in section on the line 2—2 in Fig. 1. Fig. 3 is a sectional side view, on the line 3—3 in Fig. 1. Fig. 4 is a transverse sectional view on the line 4—4 in Fig. 2. Fig. 5 is a diagrammatic side view of working parts of the engine, showing their relative position when the piston head is at the forward end of the cylinder. Fig. 6 is a diagrammatic side view of the parts shown in Fig. 5, indicating the position they assume when steam is admitted to the cylinder at the forward end. Fig. 7 represents about the relative positions of working parts when the piston is at half stroke in the cylinder; and Fig. 8 indicates the location of working features of the engine when the piston reaches the rear end of its stroke.

The cylinder A, is supported in a horizontal position on the base-plate B, by a short column A', or other suitable means, and is furnished with a steam chest A², that incases a valve seat, from which the steam ports a, extend in opposite directions to enter the cyl-

inder near its ends, an exhaust port b, being located intermediately of the live steam ports as usual.

Within the cylinder A, the piston C, of approved form is introduced, and its rod c projecting through a packing box that is formed in the rear cylinder head, has its outer end secured in the front end of the elongated cross-head D.

An imperforate cylinder head is removably secured upon the front end of the cylinder A to seal it in the ordinary way.

The cross-head D, consists of two parallel side walls that are spaced apart at each end by blocks, leaving a slot or channel of proper dimensions between them, and at the rear end said side walls are joined to the vertical arms d, which project therefrom at right angles to the top and bottom edges of the side walls.

The free ends of the arms d, loosely engage with the horizontal guide bars e, that are preferably sustained in parallel planes, by the standards f, which in pairs are erected from the bed plate at points which will adapt them to support the ends of the guide bars, or one bar may be erected from the bed plate B, as indicated in Fig. 4.

At a proper distance rearward of the guide bars e, the horizontal main shaft E, is transversely supported to rotate, by a journaled engagement of its ends with the pedestal boxes B' that are secured on the bed plate in positions which will locate them outside of the twin cranks E', that are portions of the shaft and project in the same direction, their ends farthest from the body of the shaft being joined together by the heavy crank pin E², shown in Fig. 1. On the extended ends of the shaft E, the balance wheel E³, and band wheel E⁴ are affixed. On the pin E², two eccentrics F are secured near the cranks E', having the usual encircling straps which are connected to the rods F', that extend forwardly parallel with the side walls of the cross-head D.

A substantially heart-shaped cam block G, is located in the channel of the cross-head D, and has a fixed engagement with the transverse cam shaft g, that projects at each side of said cam block through opposite longitudi-

95

100

nal slots g' that are formed in the side walls of the cross-head at a suitable distance from its ends.

A forked main connecting rod I, is provided, the limbs of which are loosely secured by adjustable straps and boxes upon the true cylindrical portions of the cam shaft g , that project beyond the cross-head walls, said limbs having a sufficient length to permit the rod to have proper clearance from the rear end of the cross-head in service, and the single member of said main rod which projects from the furcated portion toward the heavy pin E^2 , is thereto loosely connected by the usual strap and boxes.

On the ends of the cam shaft g , which extend outside of the arms of the main connecting rod I the similar crank arms g^2 are secured, which are set on radial lines about ninety degrees removed from each other, and to the outer ends of said crank arms the forward ends of the eccentric rods F' are connected by crank pins.

The cam block G, is preferably composed of two equal sections in plate form, which are parallel on the sides and are laterally secured together. As plainly shown in Figs. 2 and 3 the similar portions of the cam block, each have a curved contour that is convergent toward a point h or h^3 and oppositely from said point the half section of the cam block is incurved on the edge, thus producing two curves h' , h^2 , that are different in radius and define two rounded projections on the part they are formed upon, the out-curved edge portions of the cam sections between the points h h^3 and projections h' having a slightly elliptical curvature, and the curved edges between h or h^3 and h^2 , having the axis of the shaft g for their radial center. The two sections of the cam block G, are secured together so that the points h , and h^3 will be separated a proper degree and the out-curved portions h' , h^2 , correspondingly diverged, so that one-half of the cam block edge will be adapted to act in advance of the other half. The separation of the cam points may be dispensed with.

The axis of the cam shaft g , is the radial center of the cam projection h' , and this point on each half section of the cam is the nearest to the center of the shaft g , the points h , h^3 , being further removed therefrom, an equal degree.

At each end of the channel in the cross-head D, the anti-friction rollers i , and i are rotatably supported by a pivotal engagement with the adjustable bracket blocks i^2 , shown in Fig. 3, the roller i' being located farthest from the engine cylinder and each roller peripherally engaging with the edge of one of the cam block sections that it is opposite, while the rollers are so held in contact with the edges of the cam block sections that lost motion is prevented in either direction of travel.

There may be different forms of valve

mechanism provided for the control of steam influx and exit with regard to the cylinder of the improved engine. For the purpose of illustration, a slide valve is shown in the diagrammatic views, which valve k , is actuated by an ordinary eccentric J, that is secured on the main shaft E, and is connected to the valve by a rod J' , which is attached to the slidable valve stem k' , as indicated in Fig. 1.

When the piston head of the engine is at the forward terminal of its stroke, the eccentric F, that is on the side of the engine nearest to the valve-moving eccentric J, will be rearwardly projected, and the other eccentric F will be upwardly and forwardly projected at an angle of about ninety degrees divergence from the first mentioned eccentric, these positions being respectively indicated by the same eccentric in Figs. 5 and 6, and as the crank arms g^2 , are correspondingly "set" it will be evident that the rods F' of equal length will be adapted for a connection of the parts mentioned, as before explained.

Referring to the diagram shown in Figs. 5, 6, 7 and 8; for the sake of clearness, these views show but one eccentric F, which is nearest to the eccentric J, the connecting rod F' and main rod I, being also represented in conjunction with other working parts necessary to illustrate their relative positions during the traverse of the piston C from the front end of the cylinder to its rear end. The forward movement being the exact reversal of the rearward movement, need not be illustrated.

In Fig. 5, the piston C is shown located at the front end of the cylinder A, and the main shaft crank E' is in the same horizontal plane with the piston rod, while the cam block G, with its shaft g is forwardly adjusted, so that the cam shaft has contact with the front terminal of the slots in the side walls of the cross-head, the steam valve k , covering both of the steam ports while the cam block is in this position, and it will be seen, that this adjustment of parts locates the points h and h^3 below the cross-head about forty-five degrees removed from a line drawn through the centers of the piston rod and main shaft crank pin E^2 .

The operation of the engine is as follows: Assuming that the parts of the device by rotation in the direction of the curved arrows in Fig. 5, are arranged in the relative positions shown in said figure, the rotation of the main shaft E, carried over by its momentum, causes the main crank E' , to be carried up as shown in Fig. 6. This movement of the main crank, carries upward and backward the eccentrics F, and also causes the latter to turn on their centers. The revoluble movement of the eccentrics through their straps F' , that are connected to the crank arms g^2 , which are fast to the cam shaft g , causes a rotation of the cam shaft and cam G. The cam G, turns in contact with the roller i , and the cam shaft g , is slid backward in the slot g' , the position of parts

then being as shown in Fig. 6. At this point the slide valve *k*, is moved to admit steam to the forward end of the cylinder, this influx of steam forcing backward the piston head C, which acting through the rod *c*, that is connected to the cross head D, causes the backward thrust of the cross head. The cross head acts through the roller *i* to push against the cam G, thereby pushing backward the shaft *g*, to which the pitman I, is attached, forcing over the main shaft E. As the main shaft is caused to revolve by the further pressure of steam behind the piston head C, the eccentrics F, turn the cam G, in contact with the roller *i*, from the point *h*, to the point *h*², but as the surface line of the cam between these points is concentric with the shaft *g*, there is a constant pressure exerted by the roller against the cam, through the cam against the shaft *g* and through the shaft *g*, against the pitman I. When the parts arrive at the position shown in Fig. 8, the steam is shut off, and again the momentum of the main shaft carries it over, and the eccentrics F, turn the cam G. As the cam is rotatably moved its swell acting against the rear roller *i'*, moves the shaft *g* forward in the slot *g'*, and a reverse movement to that just described takes place.

When the working parts are moving in the direction of the curved arrow in Fig. 8, and the cam G is thereby carried down until the point *h*³ is in horizontal alignment with the center of the piston rod *c*, and shaft *g*, and has contact with the center of the rear roller *i'*, it will be evident that the other cam point *h*, will have been carried below the center line mentioned. The relative adjustment of the cam point *h*³, at the rear, will be effected when the main crank E', is on the lower quarter stroke, or in other words is inclined forwardly and upwardly from the rear below the center of the main shaft at an angle of forty-five degrees from a perpendicular plane in a position directly opposite that represented in Fig. 6.

For the efficient working of the engine the point *h*³, and roller *i*, should be in contact when the shaft *g*, is at the forward terminal of the slot *g'*, and the crank E', is on the lower quarter of its stroke as just explained, and it is for the purpose of facilitating such a relative adjustment of parts, that the cam block G, is made as shown and explained, whereby the cam points *h*, *h*³, are afforded, these being separated such a degree as will produce the results specified.

From the foregoing description it will be

seen that the cylinder A is reduced in length, and that steam pressure at each end of the stroke of the piston is cut off until the main cranks E' are removed from the dead center line about forty-five degrees, which will cause the force of the steam to be effectively utilized for the rotation of said cranks and the main shaft they are portions of. Furthermore, it will be seen that the leverage of the cranks E', is increased, while the consumption of steam is reduced proportionately in the cylinder.

Having thus described my invention, I claim as new and desire to secure by Letters Patent,—

1. In a steam engine, the combination with a cylinder, a piston, valve mechanism, a main cranked shaft, and a cross head supported on guides to reciprocate with the piston, of a cam block located in a longitudinal slot in the cross head, a transverse shaft for the cam block slidable in a slot of the cross head, a furcated pitman, and eccentric connections between the main cranked shaft and cam shaft, substantially as described.

2. The combination with a supported cylinder, a piston therein, and valve mechanism and a piston rod, of an elongated cross-head, a cam block, a transverse shaft for the cam block arranged to rotate and slide in the cross-head, cranks on projected ends of said cam shaft, a main crank shaft, eccentrics thereon, connections between the eccentrics on the main shaft and cranks on the cam shafts, and a furcated pitman connecting the cam shaft with the main crank shaft, substantially as described.

3. In a steam engine, the combination, with a bed plate, a cylinder, valve mechanism, a rotatable main shaft, two cranks thereon, joined by a heavy wrist pin, two eccentrics on said pin, and straps therefor, of a piston slidable in the cylinder, an elongated, longitudinally-channeled and slotted cross-head fast to the outer end of the piston rod, a substantially heart-shaped cam block in the channel, a transverse cam shaft fast in the cam block and loose in the slots of the cross-head, guides for the cross-head, cranks on the ends of the cam shaft, rods between said cranks and the eccentric straps, and a main furcated connecting rod, substantially as described.

HENRY I. SCHANCK.

Witnesses:

JOHN HESS,
EDWARD T. HARTSHUNE.