

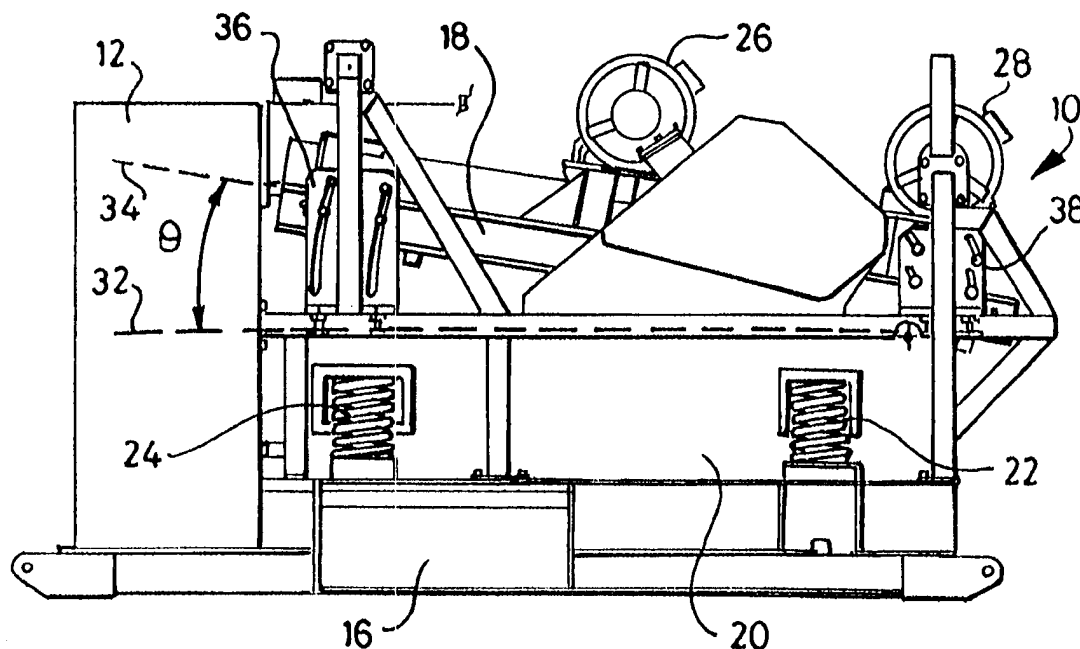

INTERNATIONAL APPLICATION PUBLISHED UNDER THE PATENT COOPERATION TREATY (PCT)

<p>(51) International Patent Classification ⁶ : B01D 35/28, B07B 1/46, E21B 21/06</p>	<p>A1</p>	<p>(11) International Publication Number: WO 98/16295 (43) International Publication Date: 23 April 1998 (23.04.98)</p>
<p>(21) International Application Number: PCT/GB96/02539 (22) International Filing Date: 15 October 1996 (15.10.96)</p> <p>(71) Applicant (for all designated States except US): RIG TECHNOLOGY LIMITED [GB/GB]; South College Street, Aberdeen AB1 2LP (GB).</p> <p>(72) Inventors; and (75) Inventors/Applicants (for US only): BAILEY, Marshall, Graham [GB/GB]; Larachmor, Burn O'Bennie, Banchory, Kincardineshire AB31 3PY (GB). BAILEY, Arthur, Robert [GB/GB]; 81 Little Sutton Lane, Sutton Coalfield, West Midlands B75 6SJ (GB). BURNETT, George, Alexander [GB/GB]; Heath Cottage, Riverstone Road, Aberdeen AB1 7JR (GB).</p> <p>(74) Agent: KEITH W. NASH & CO.; 90-92 Regent Street, Cambridge CB2 1DP (GB).</p>		<p>(81) Designated States: NO, US, ARIPO patent (KE, LS, MW, SD, SZ, UG), Eurasian patent (AM, AZ, BY, KG, KZ, MD, RU, TJ, TM), European patent (AT, BE, CH, DE, DK, ES, FI, FR, GB, GR, IE, IT, LU, MC, NL, PT, SE).</p> <p>Published With international search report.</p>

(54) Title: IMPROVED SHALE SHAKER



(57) Abstract

A shale shaker comprising two separate filter screens, one above the other, to provide an upper and a lower screen, and drive means adapted to drive the screens separately in at least lateral vibration. One or both screens are vibratable in more than one mode, for example vertical and/or horizontal and/or orbital mode. The screens may be of similar or different mesh. Typically the upper screen is of a coarser mesh than that of the lower screen.

FOR THE PURPOSES OF INFORMATION ONLY

Codes used to identify States party to the PCT on the front pages of pamphlets publishing international applications under the PCT.

AL	Albania	ES	Spain	LS	Lesotho	SI	Slovenia
AM	Armenia	FI	Finland	LT	Lithuania	SK	Slovakia
AT	Austria	FR	France	LU	Luxembourg	SN	Senegal
AU	Australia	GA	Gabon	LV	Latvia	SZ	Swaziland
AZ	Azerbaijan	GB	United Kingdom	MC	Monaco	TD	Chad
BA	Bosnia and Herzegovina	GE	Georgia	MD	Republic of Moldova	TG	Togo
BB	Barbados	GH	Ghana	MG	Madagascar	TJ	Tajikistan
BE	Belgium	GN	Guinea	MK	The former Yugoslav Republic of Macedonia	TM	Turkmenistan
BF	Burkina Faso	GR	Greece	ML	Mali	TR	Turkey
BG	Bulgaria	HU	Hungary	MN	Mongolia	TT	Trinidad and Tobago
BJ	Benin	IE	Ireland	MR	Mauritania	UA	Ukraine
BR	Brazil	IL	Israel	MW	Malawi	UG	Uganda
BY	Belarus	IS	Iceland	MX	Mexico	US	United States of America
CA	Canada	IT	Italy	NE	Niger	UZ	Uzbekistan
CF	Central African Republic	JP	Japan	NL	Netherlands	VN	Viet Nam
CG	Congo	KE	Kenya	NO	Norway	YU	Yugoslavia
CH	Switzerland	KG	Kyrgyzstan	NZ	New Zealand	ZW	Zimbabwe
CI	Côte d'Ivoire	KP	Democratic People's Republic of Korea	PL	Poland		
CM	Cameroon	KR	Republic of Korea	PT	Portugal		
CN	China	KZ	Kazakstan	RO	Romania		
CU	Cuba	LC	Saint Lucia	RU	Russian Federation		
CZ	Czech Republic	LI	Liechtenstein	SD	Sudan		
DE	Germany	LK	Sri Lanka	SE	Sweden		
DK	Denmark	LR	Liberia	SG	Singapore		
EE	Estonia						

Title: Improved Shale Shaker

Field of invention

This invention relates to a shale shaker used to separate mixtures of solids and liquids into the separate components. Such mixtures result from drilling of a borehole or tunnel when a drilling fluid is used. Separation of the components permits re-use of the drilling fluid.

Background to the invention

A shale shaker is a vibratory screening machine the function of which is to separate solids generated during the drilling of a borehole or tunnel from the drilling fluid used in the drilling process. During the drilling of a borehole or tunnel, drilling fluid is circulated from the surface through a drilling assembly and then returned to the surface. Drilled cuttings generated from the rock type being drilled are carried to the surface in the drilling fluid.

To permit re-use of the drilling fluid, a shale shaker is used at the surface to separate the drilled cuttings from the drilling fluid. The drilling fluid is then circulated through the drilling assembly again.

The nature of drilled cuttings varies widely depending on the rock type being drilled and the type of drilling fluid in use. Where a drilling fluid is predominantly comprised of water, and the rock is soft clay, a requirement to separate large volumes of sticky clay solids from the drilling fluid results. These volumes of sticky clay solids are generally referred to as Gumbo. Gumbo is often experienced when drilling young unconsolidated formations such as those found in the UK North Sea and in the USA in the Gulf of Mexico. Gumbo solids cause

severe problems in the operation of conventional shale shakers, arriving at the shakers as a large mass of sticky material which plugs the machine and coats the screen. This results in intensive manual intervention to allow the separation process to continue and often damages the screen installed on the shaker. Thus disruption to the drilling process occurs.

Summary of the invention

According to one embodiment of the invention a shale shaker comprising two separate filter screens is provided, wherein the screens are placed one above the other, to provide an upper and a lower screen, and drive means adapted to drive the screens separately in at least lateral vibration.

One or both screens may be caused to vibrate in more than one mode, for example vertical and/or horizontal and/or orbital mode.

The screens may be driven through different transmission means from a common drive means or by separate drives.

Each screen may be mounted within its own material containing means, which typically comprises a tray-like structure having walls, to contain mixtures of liquid and solid materials therein.

The upper screen may be tilted relative to the horizontal.

The screens may be of similar or different mesh. Thus both might be 100 mesh.

Alternatively the mesh of the upper screen may be different from that of the lower.

Typically the upper screen is of a coarser mesh than that of the lower screen.

Each of the two screens may be formed from a single cloth or

from two or more cloths, stretched over a frame.

Where at least two cloths are employed, one cloth may be placed above the other, lower cloths preferably having a significantly coarser mesh than upper cloths.

Likewise where the screen comprises at least two cloths, the mesh tension may differ between the cloths.

The cloths may be formed from woven wire.

The wire may be of metal or plastics or plastics coated metal.

Variation of the throughput performance of the shaker is obtainable by adjusting the screen drives and/or modes of vibration of one or other or both of the screens.

In a further aspect of the invention, a method of separating solids from liquids comprises:

- (1) supplying a mixture of solids and liquids to an upper vibrating screen, and
- (2) collecting filtered material from the upper screen on a lower screen located therebelow, and
- (3) vibrating the lower screen independently of the upper screen.

Preferably the vibration of the screens is adjustable during the separation process so as to allow the separation of different solid-liquid combinations during filtering.

The invention will now be described by way of example with reference to the accompanying drawings in which:

Figure 1 is a series of views of a prior art shale shaker, where Figure 1(a) is a front elevation, Figure 1(b) a side elevation and Figure 1(c) a plan view of the shale shaker;

Figure 2 is a series of views of a shale shaker embodying the present invention with an upper containing means for containing a fluid and solid mixture to be separated, where Figure 2(a) is a front elevation, Figure 2(b) a side elevation and Figure 2(c) a plan view of the shale shaker;

Figure 3 is a series of detailed views of the upper containing means used in a shale shaker embodying the invention showing vibratory elements used to shake the upper containing means, where Figure 3(a) is a front elevation, Figure 3(b) a side elevation and Figure 3(c) a plan view of the upper containing means;

Figure 4 is a side elevation of the shale shaker as shown in Figure 2 with the upper containing means in a tilted position for processing of the mixtures; and

Figure 5 is a schematic illustration of alteration of the vibratory motion of the upper containing means by adjustment of the relevant forces of individual vibrating elements.

Referring to Figure 1, a convention shale shaker is shown, the shale shaker being used for separating drilled cuttings from a drilling fluid before re-circulation of the drilling fluid for continued use in the drilling process.

Prior art shakers such as shown in Figure 1 typically comprise a feed tank 1, a skid assembly 2, a shaker basket 3, where the single shaker basket is mounted on springs 3c, a vibrator assembly 4 and a feed chute 5. The basket 3 contains two screening decks 3a, 3b. The screening decks 3a, 3b are normally made of woven wire mesh although other materials may be used.

In use, a mixture of solids and fluid enters the feed tank 1 and passes via a feed chute 5, to the shaker basket 3. Fluid passes through the screen 3a, 3b and solids are retained on the

screen mesh. The shaker basket 3 is vibrated by the vibrator assembly 4 to produce a linear motion of the basket. The vibratory action of the shaker basket 3 acts to assist the passage of fluid through the mesh and to transport the solids retained on the screen face to a point of discharge at the end of the screen. Solids are ideally discharged with the minimum volume of fluid attached. The vibratory motion of the shaker basket is either orbital or linear. It is generally accepted that Gumbo solids are more easily processed using an orbital motion. Many other solids are more easily processed using linear motion.

A shale shaker embodying the invention is shown in Figure 2. The front elevation of the shale shaker 10 is shown in Figure 2(a), a side elevation is shown in 2(b) with a plan view of the shale shaker shown in Figure 2(c). The shale shaker 10 comprises a feed tank 12, a feed chute 14, a skid assembly 16 and two containing means, or shaker baskets, 18, 20, each basket having a sifting deck with mesh screen. The baskets 18, 20 are independently mounted on individual sets of springs. One pair of springs 22, 24 on which the baskets 18, 20 are supported is shown. The springs used for supporting the baskets 18, 20 are in turn independently supported from the skid assembly 16.

Vibratory elements are attached to the containing means 18, 20. Two vibratory elements 26, 28 vibrate the upper containing means 18. A further vibratory element 30 vibrates the lower containing means 20.

In use, a liquid and solid mixture produced from a drilling process is fed into the feed tank 12. The mixture is fed via the feed chute 14 into the upper containing means 18. The vibratory elements 26, 28 vibrate the upper containing means 18 with a linear motion or a orbital motion, or a motion which is a combination of these. As the upper containing means 18 vibrates, the fluid and solid mixture contained therein is

vibrated against the sifting deck. The liquid and some of the solid particles pass through the separating mesh in the sifting deck which forms the base of the upper containing means 18 and passes through to the lower containing means 20.

A detailed view of the upper containing means 18, is shown in Figures 3(a), 3(b) and 3(c). The upper containing means 18 comprises a rectangular base, or sifting deck, 32 with side walls 34, 34'. The sifting deck 32 comprises a series of longitudinal and horizontal struts on which a mesh 36 is supported. The vibratory elements 26, 28 are attached to the upper containing means 18 as shown in Figure 3(b).

As vibration of the upper containing means 18 is effected by the vibratory elements 26, 28, the solid and fluid mixture is forced by varying degrees through the mesh screen 36. The mesh screen 36 is typically a woven wire mesh and may be provided by one layer of mesh cloth or alternatively by two layers of mesh cloth. The cloths may be of different grades of mesh and of differing tensions.

The partially separated solid and liquid mixture passes into the lower containing means 20. Further sifting of the partially separated solid and liquid mixture is then carried out in the lower containing means in a similar manner to that as described for the upper containing means 18 except that only one vibratory element 30 is used.

In a particularly preferred embodiment, the upper containing means 18 is mounted so that the angle of operation to the horizontal is variable. Typically the upper containing means can be tilted between the horizontal to 10° in either an up sloped or down sloped direction. Figure 4 shows the upper containing means 18 in such a tilted position, where adjustment into a down sloped position has occurred. The same reference numerals have been used for those items already described. The line of the horizontal is depicted by line 32 with the angle

to the horizontal by line 34. A variable adjusting means 36 is adjusted about a pivot means 38 to alter the inclination of the containing means 18.

The vibratory motion of the upper containing means 18 is controlled by varying the speed and or the direction of rotation, and or the force of vibrations of the two vibratory elements 26, 28 relative to one another. Further the vibratory elements may be movable in a lateral or vertical direction relative to the upper containing means 18 so that the position of the vibratory elements relative to one another and the screen can be varied.

Figure 5 shows a schematic diagram illustrating how the screen vibration movement may be altered by varying the clump weight settings of the vibratory elements 26, 28. By increasing the front vibrational force from vibratory element 18 a flatter ellipse movement of the screen results. Through adjustment of these variables, the motion of the upper containing means 18 can be set for the processing of, for example, Gumbo and then adjusted further on in the sifting process to process other different solid - fluid combinations. The shale shaker as described employs both linear and orbital motion for separation of solids from solid-fluid mixtures and is adjustable for separation of different combinations of solids and fluids.

Claims

1. A shale shaker comprising two separate filter screens, one above the other, to provide an upper and a lower screen, and drive means adapted to drive the screens separately so that each vibrates in at least one mode of vibration.
2. A shale shaker according to claim 1, wherein at least one of the screens is caused to vibrate in more than one mode.
3. A shale shaker according to claims 1 or 2, wherein the screens are driven through different transmission means from a common drive means.
4. A shale shaker according to claims 1 or 2, wherein the screens are driven by separate drives.
5. A shale shaker according to any of claims 1 to 4, wherein each screen is mounted within its own material containing means, to contain mixtures of liquid and solid materials therein.
6. A shale shaker according to any of the preceding claims, wherein the upper screen is tilted relative to the horizontal.
7. A shale shaker according to any of the preceding claims, wherein the screens are of similar mesh.
8. A shale shaker according to any of claims 1 to 6, wherein the mesh of the upper screen is different from that of the lower.
9. A shale shaker according to claim 8, wherein the upper screen is of a coarser mesh than that of the lower screen.
10. A shale shaker according to any of the preceding claims, wherein each of the two screens is formed from a single cloth

stretched over a frame.

11. A shale shaker according to any of claims 1 to 9, wherein each of the two screens is formed from at least two cloths stretched over a frame.

12. A shale shaker according to claim 11, wherein the cloths are placed one above the other.

13. A shale shaker according to claim 12, wherein lower cloths have significantly coarser mesh than upper cloths.

14. A shale shaker according to any of claims 11 to 13, wherein the mesh tension differs between the cloths.

15. A shale shaker according to claims 10 to 14, wherein the cloths are formed from woven wire.

16. A shale shaker according to claim 15, wherein the wire is of metal or plastics or plastics coated metal.

17. A shale shaker according to any of the preceding claims, wherein the vibration of the screens is adjustable so as to allow the separation of different solid-liquid combinations during filtering.

18. A method of separating solids from liquids comprising the steps of:

(i) supplying a mixture of solids and liquids to an upper vibratory screen,

(ii) collecting filtered material from the upper screen on a lower screen located therebelow, and

(iii) vibrating the lower screen independently of the upper screen.

19. A method of separating solids from liquids according to claim 18, in which the vibration of the screens is adjustable during the separation process so as to allow for separation of different solid-liquid combinations.

20. A shale shaker as claimed in claim 1, wherein screens vibrate in a linear vibration mode.

21. A shale shaker as claimed in claim 2, wherein the said at least one screen vibrates linearly and orbitally.

22. A shale shaker as claimed in claim 2, wherein the said at least one screen is vibrated so as to describe an elliptical path.

23. A shale shaker as described in claim 22, wherein both screens are vibrated so as to describe elliptical paths.

1/4

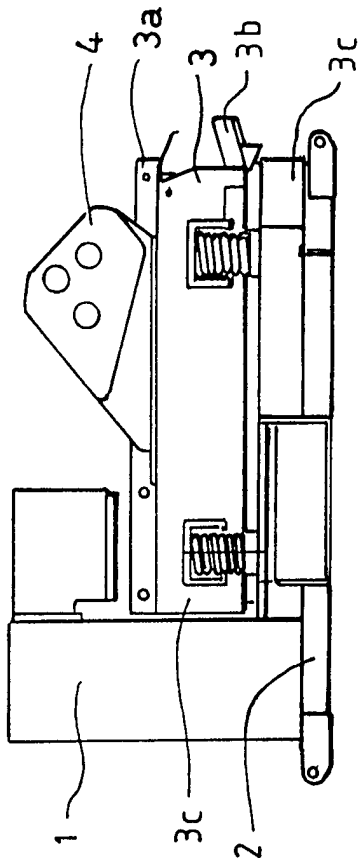

Fig. 1.(b)

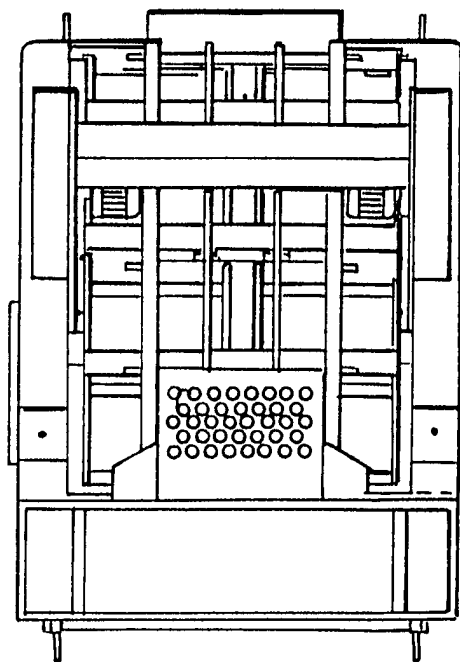

Fig.1(c)

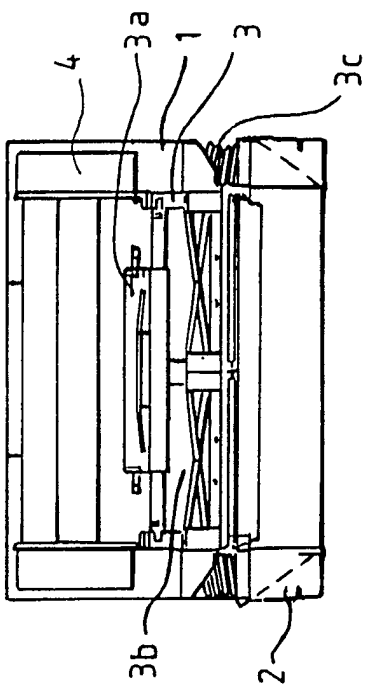

Fig.1 (a)

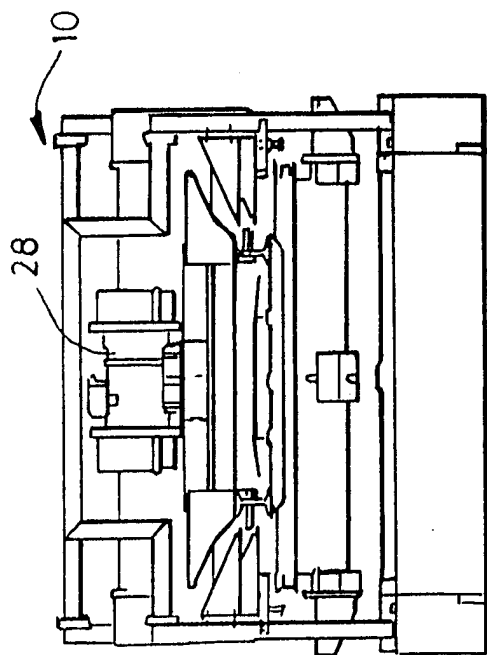

Fig. 2 (a)

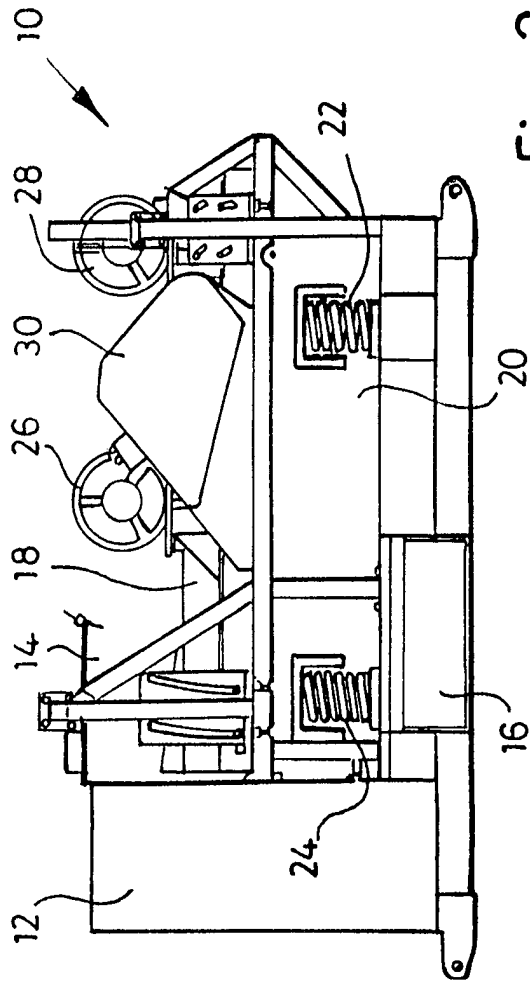

Fig. 2 (b) ^{2/4}

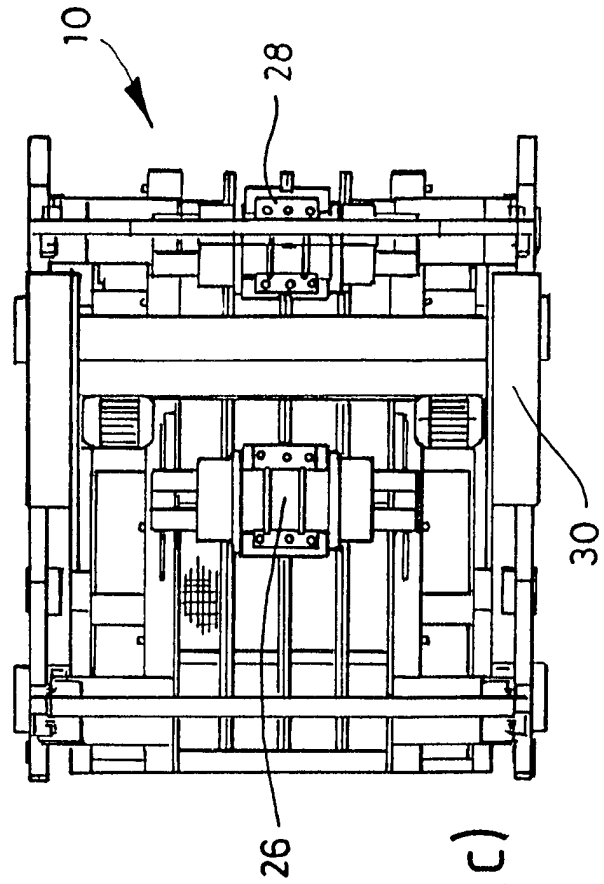

Fig. 2 (c)

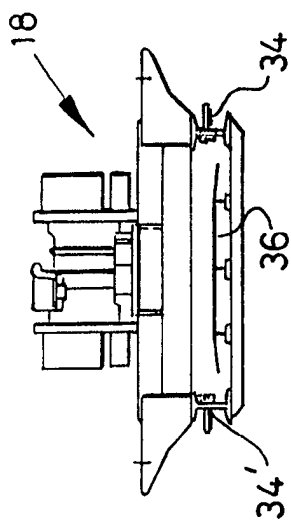

Fig. 3(a)

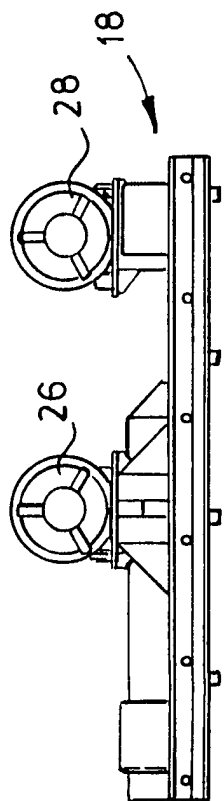

Fig. 3 (b)

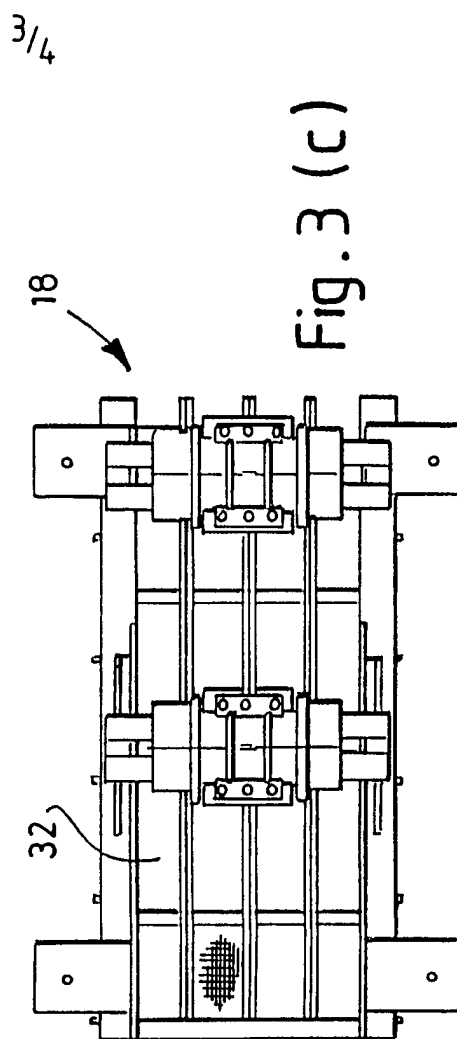

Fig. 3 (c)

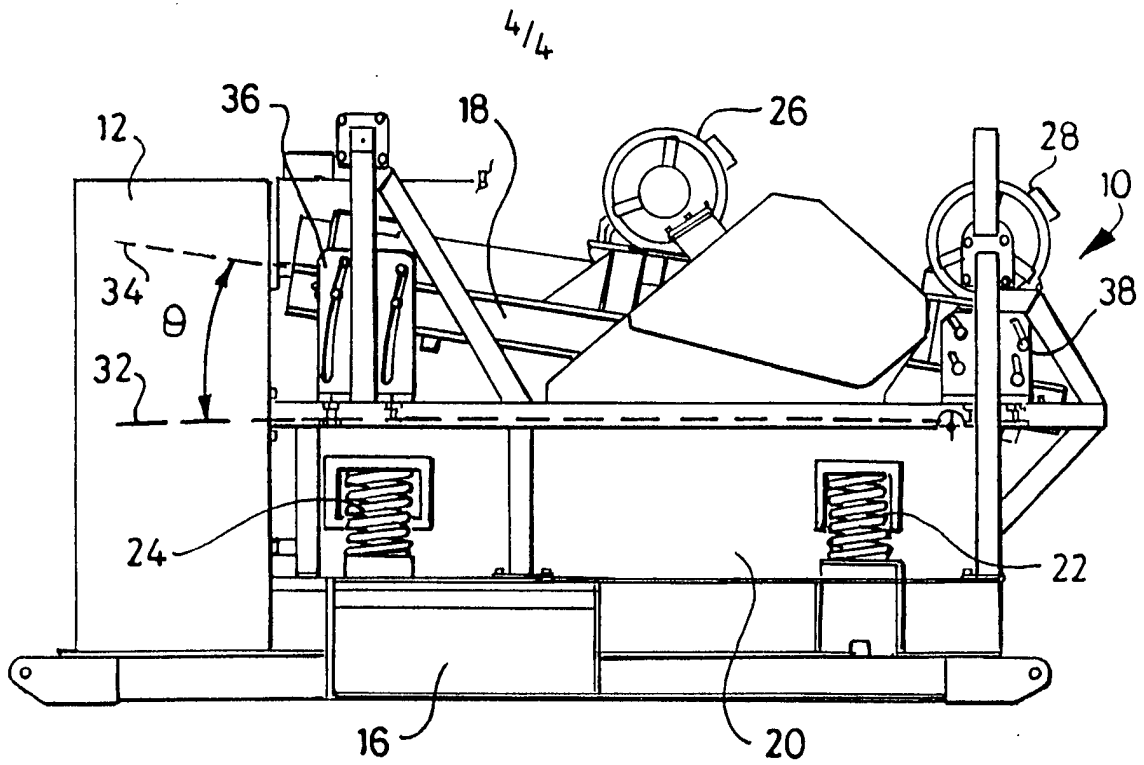

Fig. 4

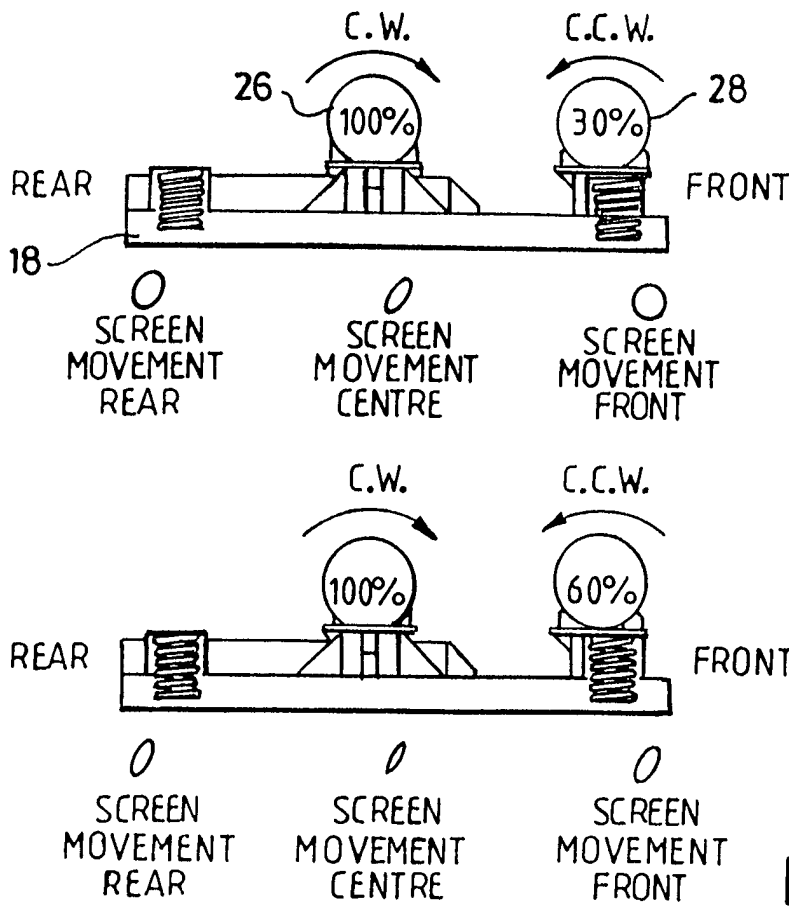

Fig. 5

INTERNATIONAL SEARCH REPORT

Inte. .onal Application No

PCT/GB 96/02539

A. CLASSIFICATION OF SUBJECT MATTER
 IPC 6 B01D35/28 B07B1/46 E21B21/06

According to International Patent Classification (IPC) or to both national classification and IPC

B. FIELDS SEARCHED

Minimum documentation searched (classification system followed by classification symbols)

IPC 6 B01D B07B E21B

Documentation searched other than minimum documentation to the extent that such documents are included in the fields searched

Electronic data base consulted during the international search (name of data base and, where practical, search terms used)

C. DOCUMENTS CONSIDERED TO BE RELEVANT

Category *	Citation of document, with indication, where appropriate, of the relevant passages	Relevant to claim No.
X	US 4 354 513 A (BINGHAM MARION G ET AL) 19 October 1982 see column 2, line 52 - column 3, line 15; claim 1; figure 2 ---	1,4-6, 17,18
X	US 4 082 657 A (GAGE ERNEST L) 4 April 1978 see the whole document ---	1,18
A	US 3 766 997 A (HEILHECKER J ET AL) 23 October 1973 see the whole document ---	1,18
A	US 5 392 925 A (SEYFFERT KENNETH W) 28 February 1995 see claim 4; figure 1 ---	1,18
	-/--	

Further documents are listed in the continuation of box C.

Patent family members are listed in annex.

* Special categories of cited documents :

- "A" document defining the general state of the art which is not considered to be of particular relevance
- "E" earlier document but published on or after the international filing date
- "L" document which may throw doubts on priority claim(s) or which is cited to establish the publication date of another citation or other special reason (as specified)
- "O" document referring to an oral disclosure, use, exhibition or other means
- "P" document published prior to the international filing date but later than the priority date claimed

- "T" later document published after the international filing date or priority date and not in conflict with the application but cited to understand the principle or theory underlying the invention
- "X" document of particular relevance; the claimed invention cannot be considered novel or cannot be considered to involve an inventive step when the document is taken alone
- "Y" document of particular relevance; the claimed invention cannot be considered to involve an inventive step when the document is combined with one or more other such documents, such combination being obvious to a person skilled in the art.
- "&" document member of the same patent family

Date of the actual completion of the international search

18 March 1997

Date of mailing of the international search report

14.04.97

Name and mailing address of the ISA

European Patent Office, P.B. 5818 Patentlaan 2
 NL - 2280 HV Rijswijk
 Tel. (+ 31-70) 340-2040, Tx. 31 651 epo nl,
 Fax: (+ 31-70) 340-3016

Authorized officer

Hild, U

INTERNATIONAL SEARCH REPORT

International Application No

PCT/GB 96/02539

C.(Continuation) DOCUMENTS CONSIDERED TO BE RELEVANT

Category *	Citation of document, with indication, where appropriate, of the relevant passages	Relevant to claim No.
A	US 4 634 535 A (LOTT W GERALD) 6 January 1987 see column 3, line 36 - column 5, line 20; figure 5 ---	1,18
E	GB 2 299 771 A (RIG TECHNOLOGY LTD) 16 October 1996 see the whole document -----	1-23

INTERNATIONAL SEARCH REPORT

Information on patent family members

International Application No

PCT/GB 96/02539

Patent document cited in search report	Publication date	Patent family member(s)	Publication date
US 4354513 A	19-10-82	GB 2089403 A	23-06-82
US 4082657 A	04-04-78	NONE	
US 3766997 A	23-10-73	NONE	
US 5392925 A	28-02-95	NONE	
US 4634535 A	06-01-87	NONE	
GB 2299771 A	16-10-96	NONE	