



US00D717700S

(12) **United States Design Patent**
Dasbach

(10) **Patent No.:** **US D717,700 S**
(45) **Date of Patent:** **** Nov. 18, 2014**

- (54) **MEMBER OF A FRAME FOR A BIKE**
- (71) Applicant: **Robert Bosch GmbH**, Stuttgart (DE)
- (72) Inventor: **Gregor Dasbach**, Mondeville (FR)
- (73) Assignee: **Robert Bosch GmbH**, Stuttgart (DE)
- (**) Term: **14 Years**
- (21) Appl. No.: **29/446,444**
- (22) Filed: **Feb. 23, 2013**

- (30) **Foreign Application Priority Data**
- Aug. 23, 2012 (EM) 002091330
- Oct. 5, 2012 (EM) 002114223

- (51) **LOC (10) Cl.** **12-11**
- (52) **U.S. Cl.**
- USPC **D12/111**

- (58) **Field of Classification Search**
- USPC D12/111, 117, 223, 112; 280/243, 246, 280/247, 252, 255, 263, 282, 281.1, 274, 280/283, 288.3, 259, 278, 287, 261, 280/124.103, 87.05, 87.1, 638, 288.4, 280/87.041, 258, 210, 279; D34/18
- See application file for complete search history.

- (56) **References Cited**
- U.S. PATENT DOCUMENTS
- 5,593,168 A * 1/1997 Chou 280/275
- D379,163 S * 5/1997 Lai D12/111
- D385,228 S * 10/1997 Thompson et al. D12/111
- D386,451 S * 11/1997 Liao D12/111
- D396,670 S * 8/1998 Wasserhess et al. D12/111
- D610,047 S * 2/2010 Uimonen D12/111

8,439,382 B2 *	5/2013	Tortola	280/281.1
D683,661 S *	6/2013	Horne	D12/111
D693,739 S *	11/2013	Uimonen	D12/111
D693,740 S *	11/2013	Eagleman et al.	D12/111
2003/0193159 A1 *	10/2003	Ridenhour	280/255
2007/0007745 A1 *	1/2007	Shim et al.	280/282
2008/0197603 A1 *	8/2008	Wei Lin	280/281.1

* cited by examiner

Primary Examiner — Eric Goodman
Assistant Examiner — Ryan Harvey
 (74) *Attorney, Agent, or Firm* — Maginot, Moore & Beck LLP

(57) **CLAIM**
 The ornamental design for a member of a frame for a bike, as shown and described.

DESCRIPTION

FIG. 1 is a perspective view of a member of a frame for a bike showing my new design;
 FIG. 2 is a left side elevational view showing the design for the frame member of FIG. 1;
 FIG. 3 is a right side elevational view showing the design for the frame member of FIG. 1;
 FIG. 4 is a front elevational view showing the design for the frame member of FIG. 1;
 FIG. 5 is a rear elevational view showing the design for the frame member of FIG. 1;
 FIG. 6 is a top elevational view showing the design for the frame member of FIG. 1; and,
 FIG. 7 is a bottom elevational view showing the design for the frame member of FIG. 1.

The broken lines shown in the drawings are included for the purpose of illustrating unclaimed portions of the frame member and form no part of the claimed design.

1 Claim, 7 Drawing Sheets

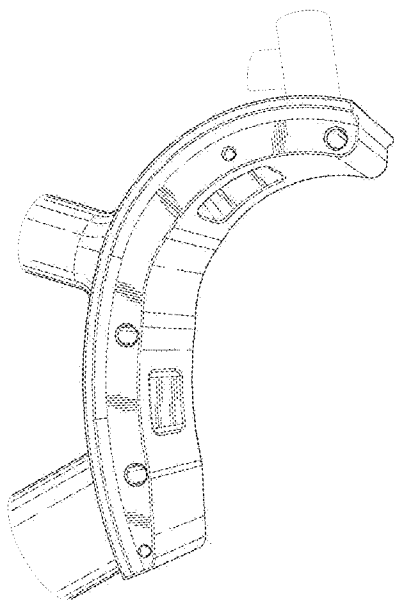

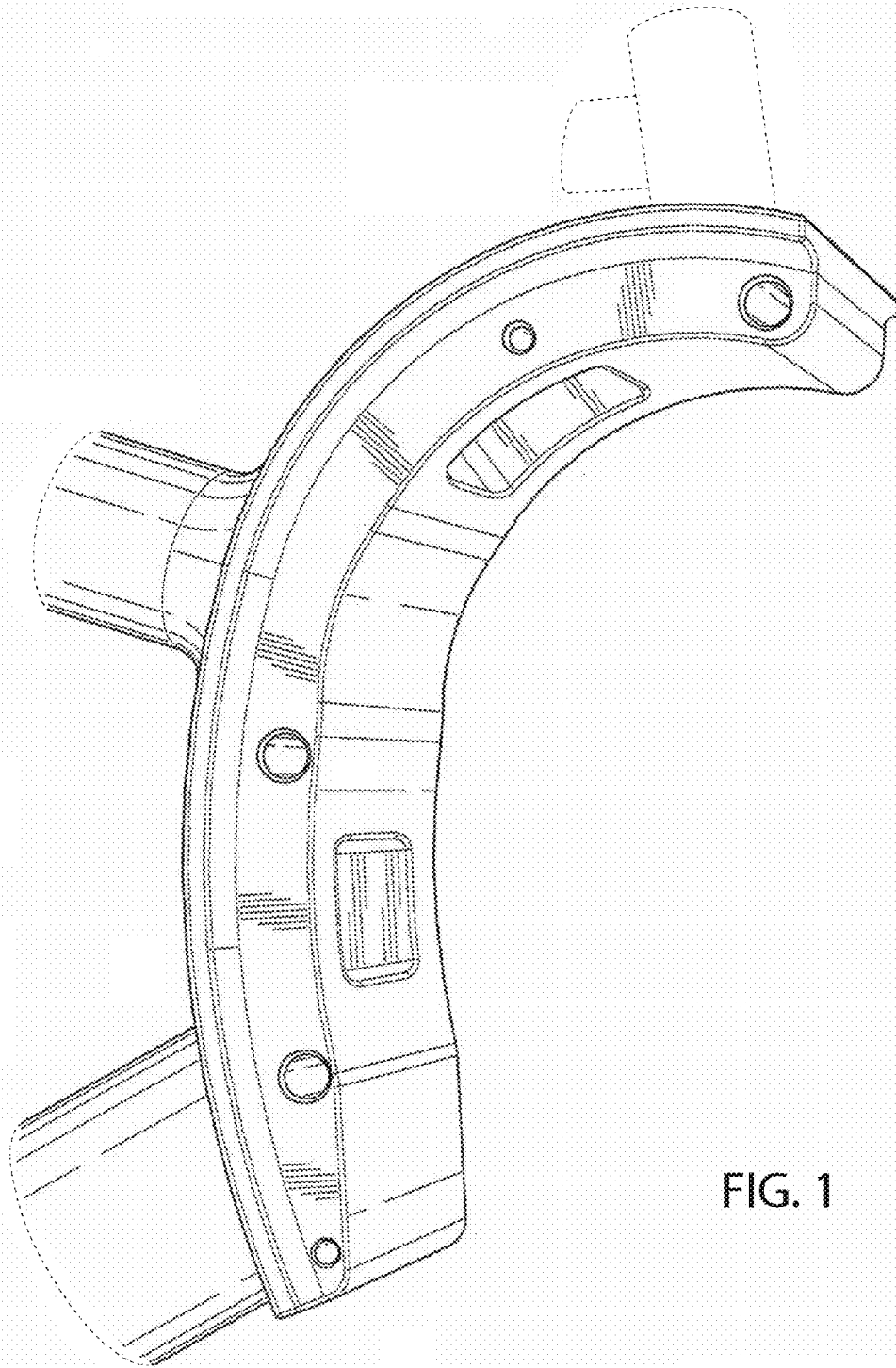

FIG. 1

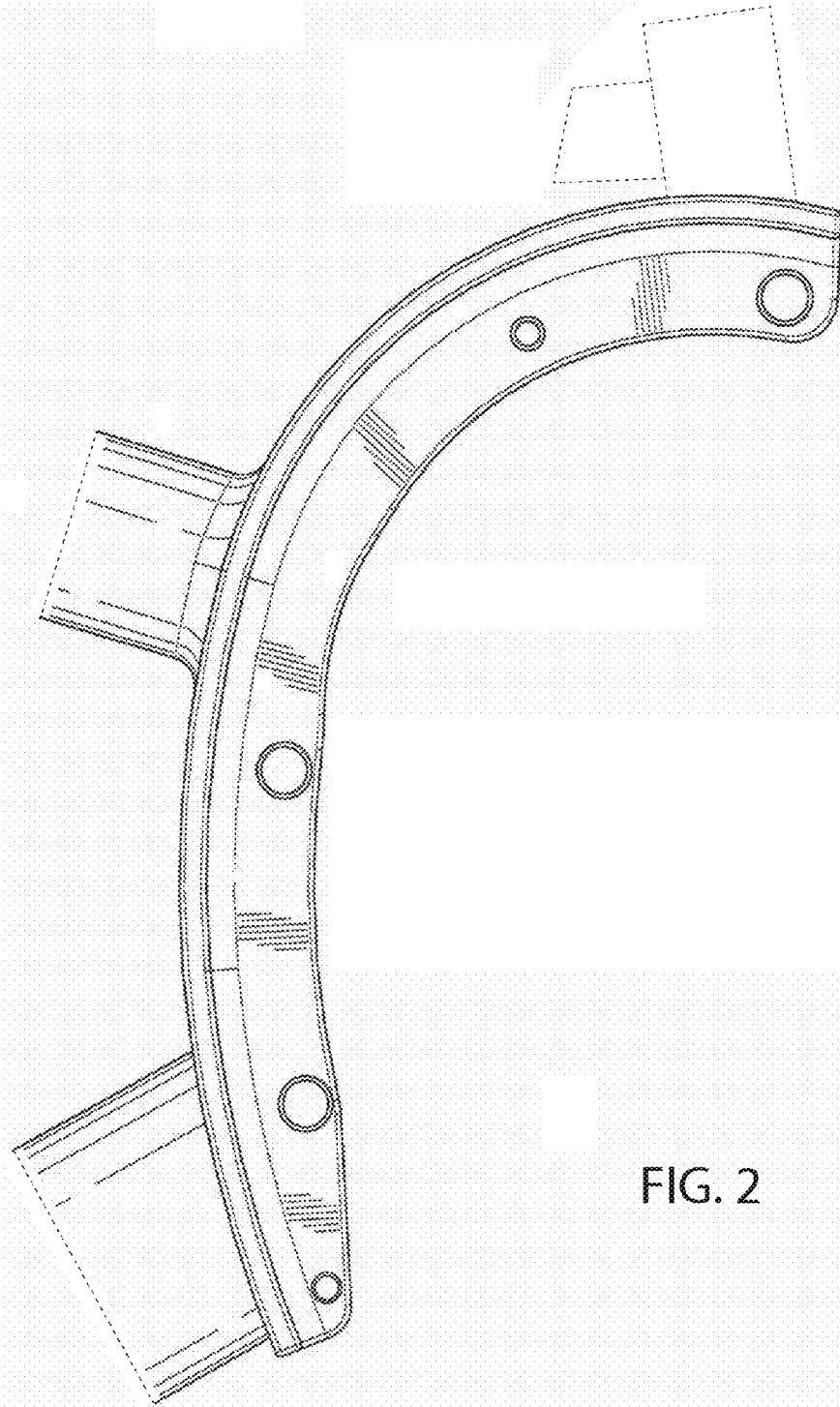

FIG. 2

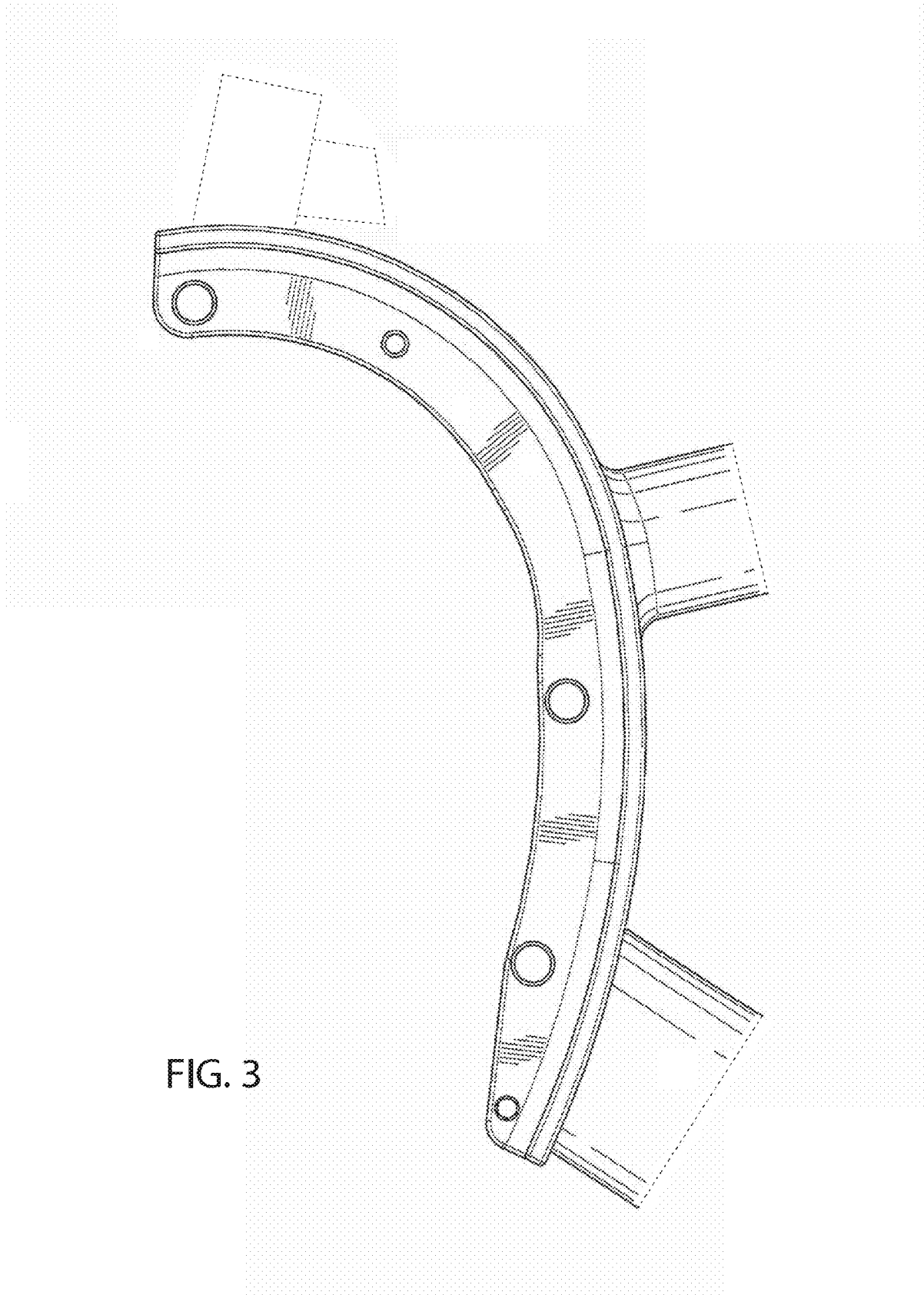

FIG. 3

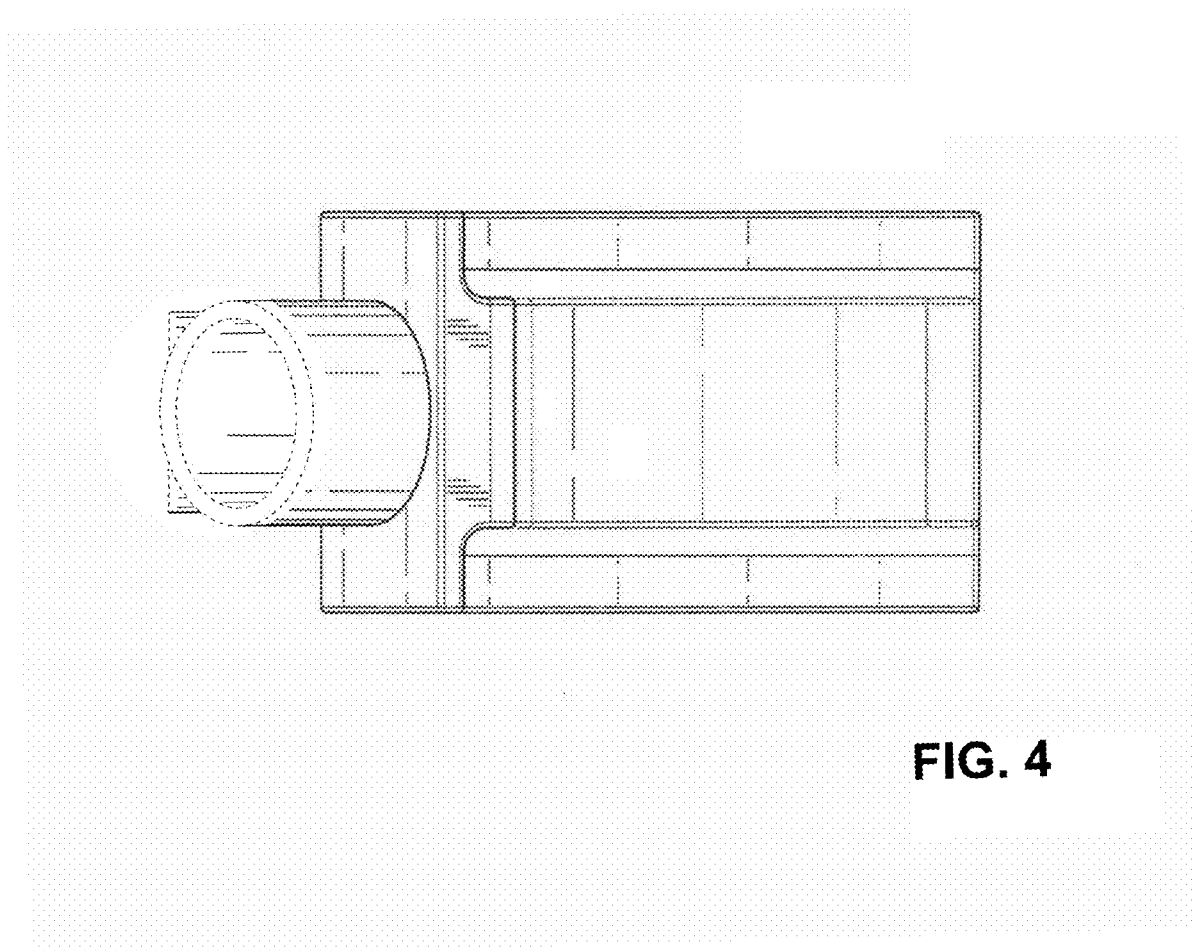

FIG. 4

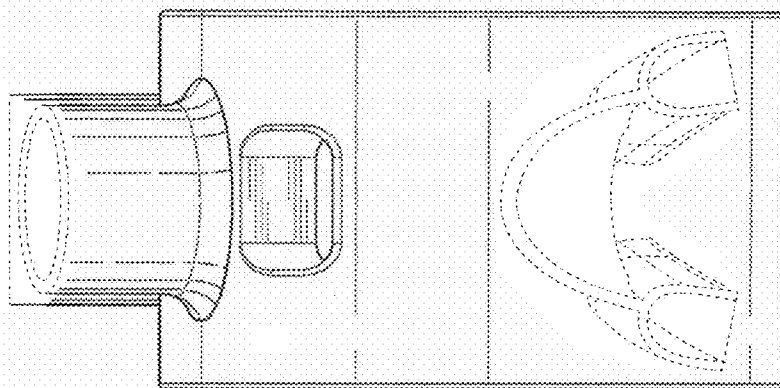

FIG. 5

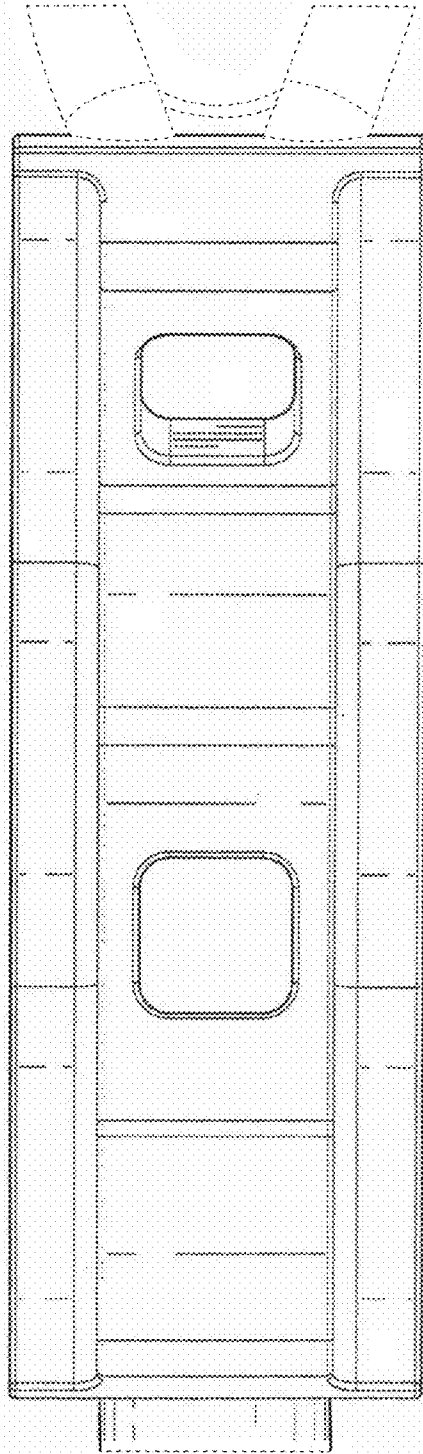

FIG. 6

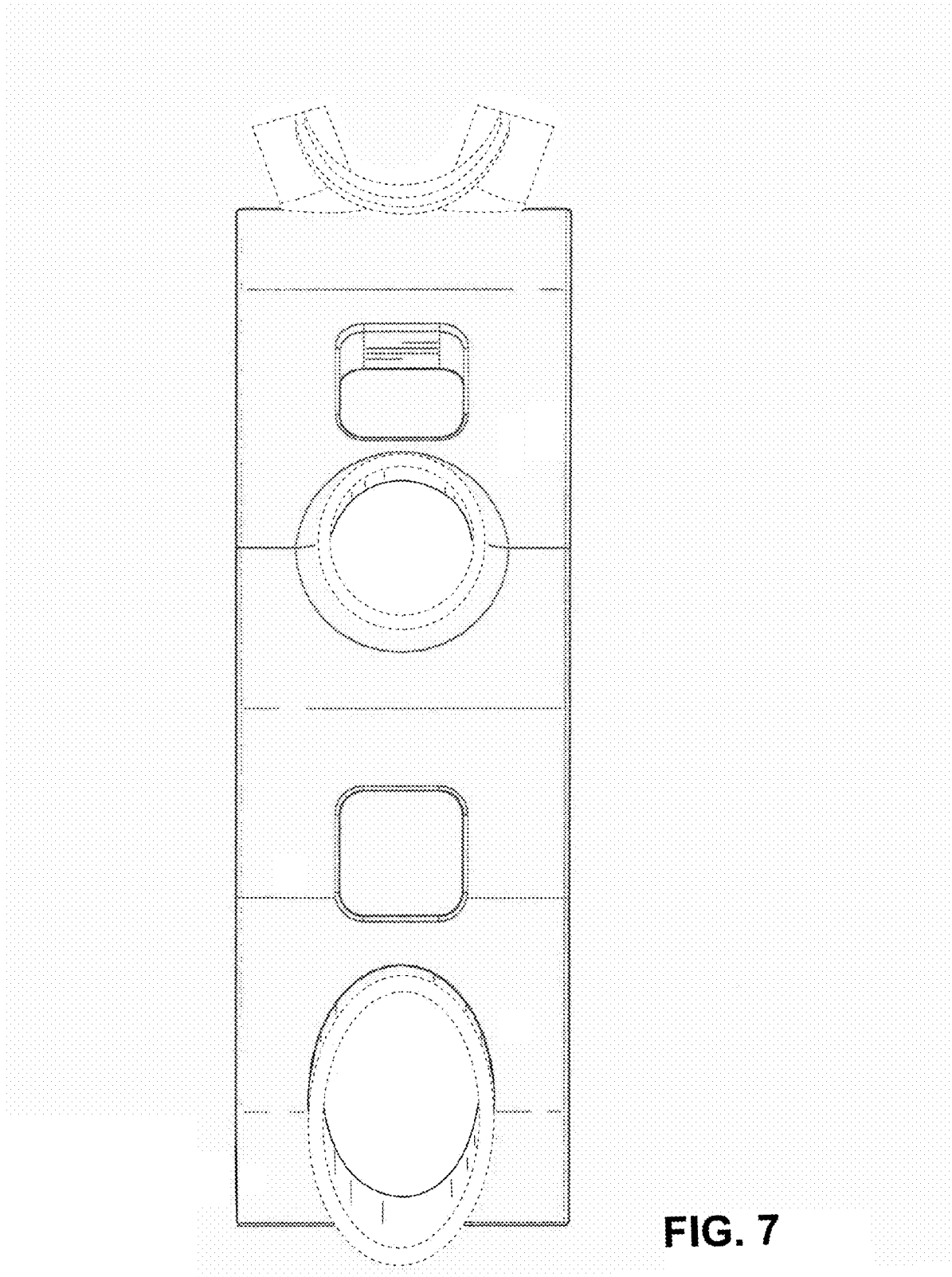

FIG. 7