



(19) **United States**

(12) **Patent Application Publication**
Hembree

(10) **Pub. No.: US 2001/0041518 A1**

(43) **Pub. Date: Nov. 15, 2001**

(54) **APPARATUS AND METHODS FOR
SUBSTANTIAL PLANARIZATION OF
SOLDER BUMPS**

(57) **ABSTRACT**

(76) Inventor: **David R. Hembree**, Boise, ID (US)

Correspondence Address:

Dale C. Barr, Esq.
DORSEY & WHITNEY LLP
Suite 3400
1420 Fifth Avenue
Seattle, WA 98101 (US)

(21) Appl. No.: **09/910,334**

(22) Filed: **Jul. 19, 2001**

Related U.S. Application Data

(62) Division of application No. 09/715,691, filed on Nov. 17, 2000.

Publication Classification

(51) **Int. Cl.⁷ B24B 7/00**

(52) **U.S. Cl. 451/69; 451/70**

Apparatus and methods for substantial planarization of solder bumps. In one embodiment, an apparatus includes a planarization member engageable with at least some of the plurality of outer surfaces to apply a planarization action on one or more of the outer surfaces to substantially planarize the plurality of outer surfaces, and a securing element to securely position the bumped device during engagement with the planarization member. Through application of "additive" and/or "subtractive" processes, the solder balls are substantially planarized. In alternate embodiments, the planarization member includes a cutting tool and the planarization action comprises a milling action; or the planarization member includes a heated platen and the planarization action comprises a thermo-mechanical deformation action; or the planarization member includes an abrasive surface and the planarization action comprises a grinding action; or the planarization member includes a chemical solution and the planarization action comprises a chemical reaction; or the planarization member includes a solder deposition device and the planarization action comprises a solder. In a further embodiment, an apparatus includes a load device to urge the at least some outer surfaces of the bumped device into engagement with the planarization member.

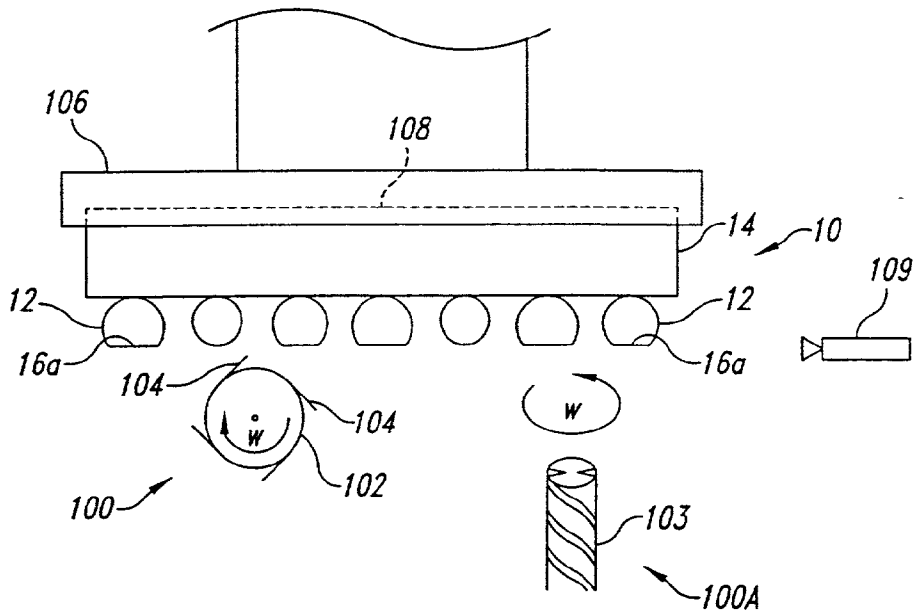

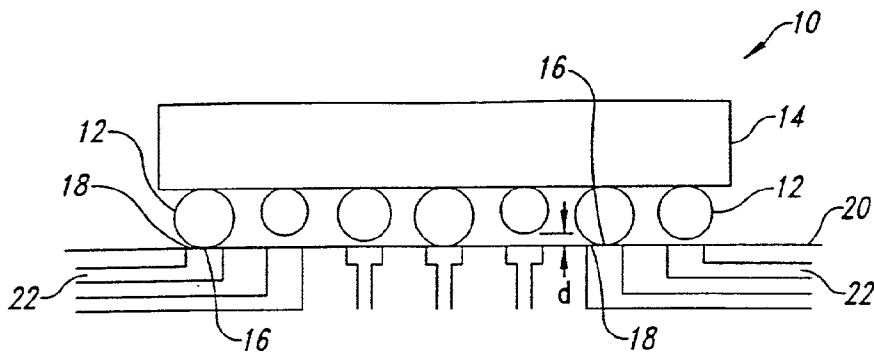

Fig. 1
(Prior Art)

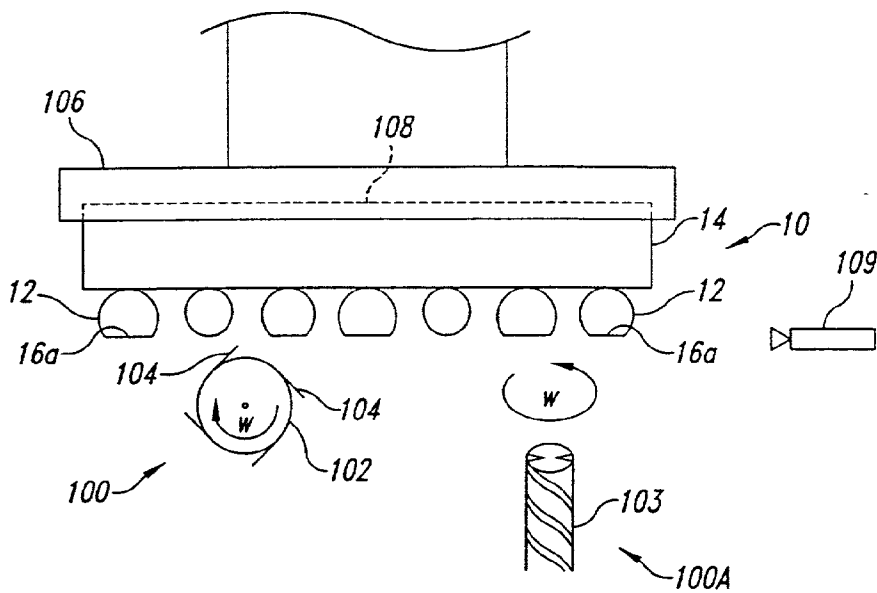

Fig. 2

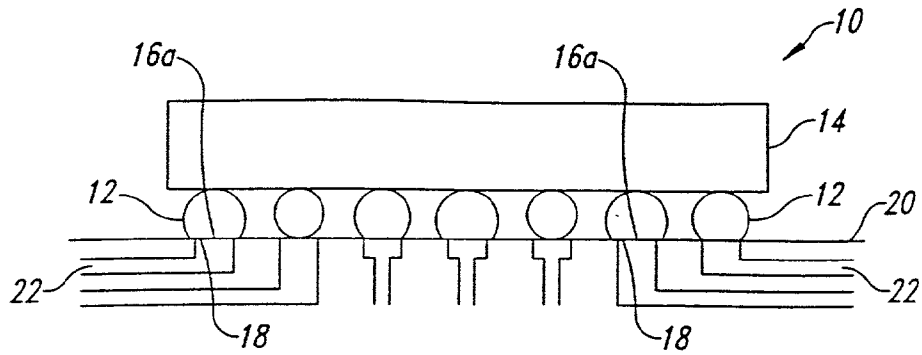

Fig. 3

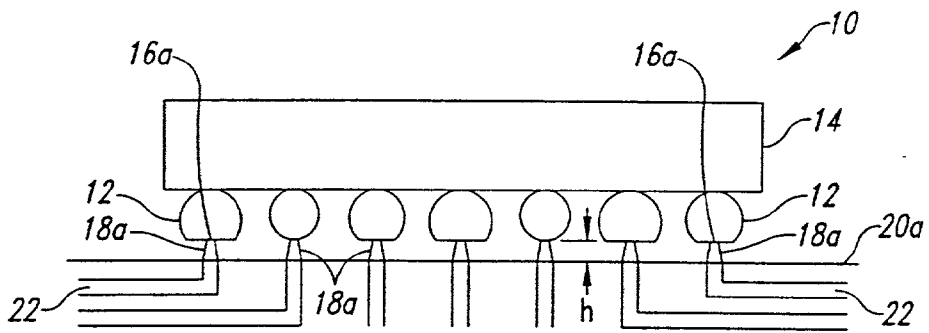

Fig. 4

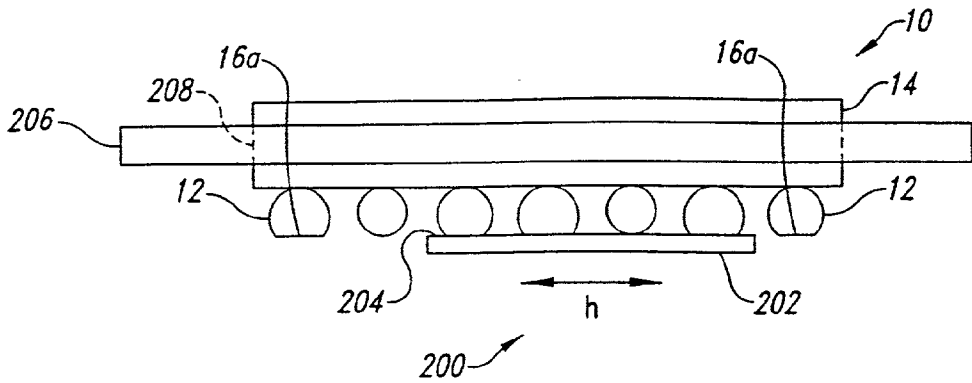

Fig. 5

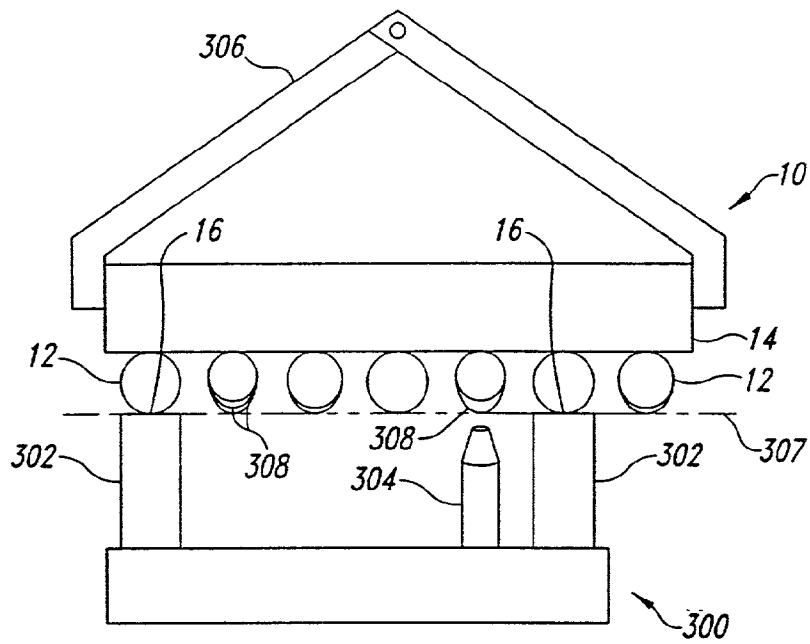

Fig. 6

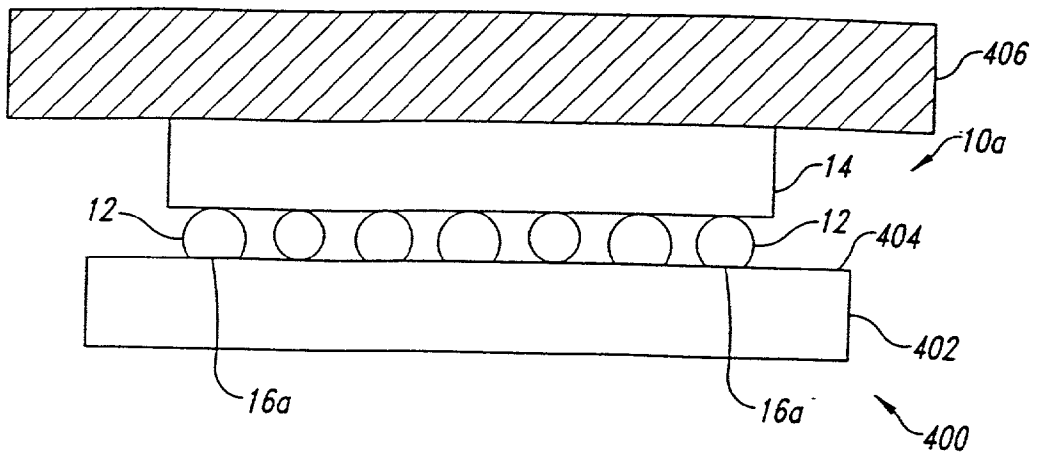

Fig. 7

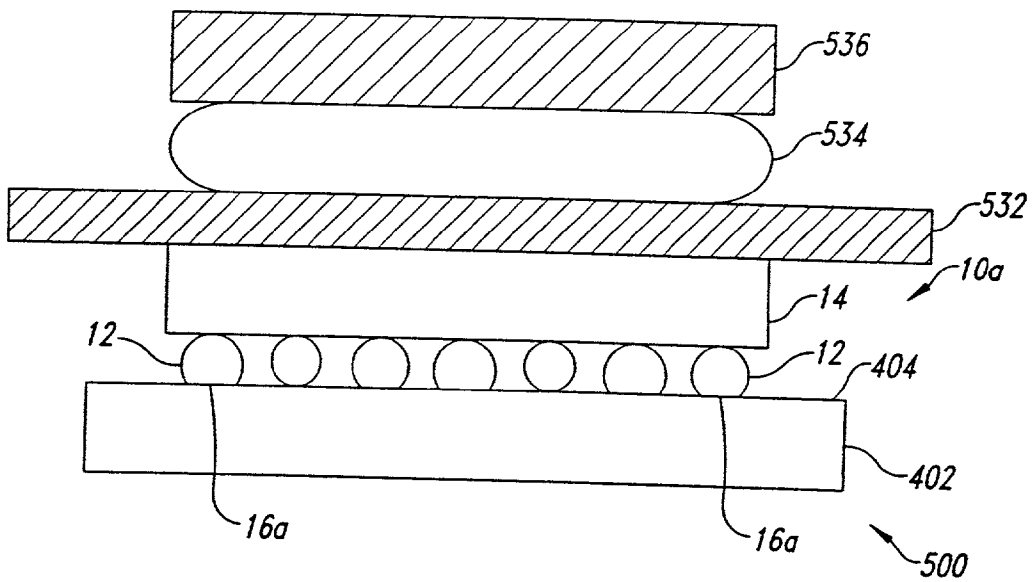

Fig. 8

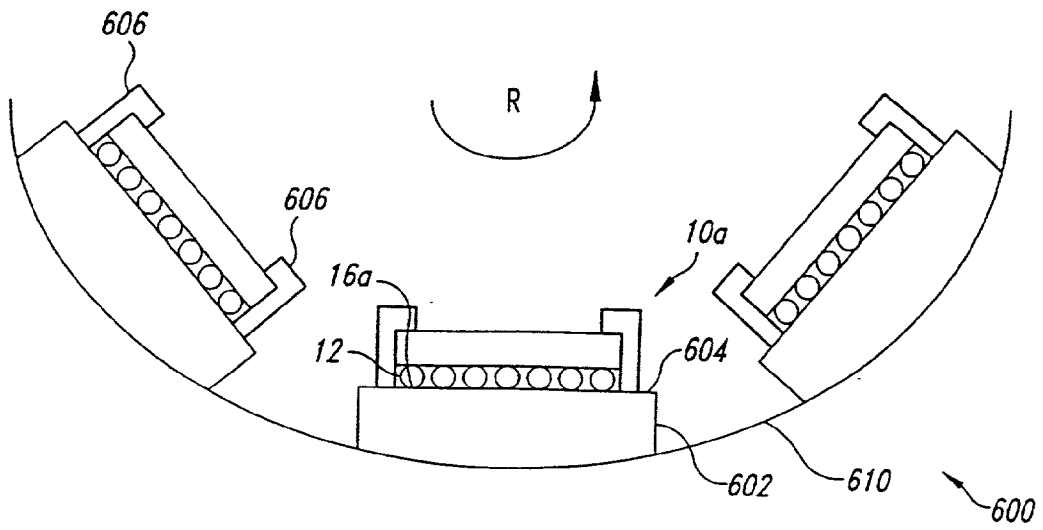

Fig. 9

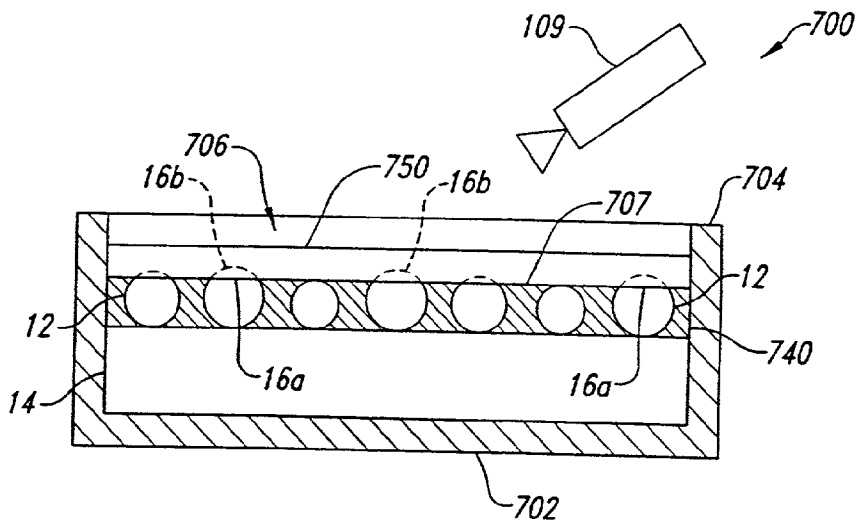

Fig. 10

APPARATUS AND METHODS FOR SUBSTANTIAL PLANARIZATION OF SOLDER BUMPS

TECHNICAL FIELD

[0001] The present invention relates to apparatus and methods for substantial planarization of solder bumps for use in, for example, testing and fabrication of chip scale packages, bumped die, and other similar devices.

BACKGROUND OF THE INVENTION

[0002] The demand for smaller packaging of electronic components continues to drive the development of smaller chip scale packages (CSP's), bumped die, and other similar devices having solder bumps, ball grid arrays (BGA's), or the like. As a result, spacing (or "pitch") between adjacent solder balls on bumped devices has steadily decreased. Typical requirements for ball pitch have decreased from 1.27 mm to 0.5 mm or less, and the trend continues.

[0003] FIG. 1 is a side elevational view of a typical bumped device **10** (CSP, bumped die, etc.) mounted on, for example, a printed circuit board **20**. The bumped device **10** includes a plurality of solder balls **12** attached to a plurality of ball pads (not shown) which are formed on a die **14**. Each solder ball **12** has an outer edge **16** that aligns with a corresponding contact pad **18** on the printed circuit board **20**. A conductive lead **22** is attached to each contact pad **18**. Ideally, the outer edge **16** of each solder ball **12** contacts the corresponding contact pad **18** during assembly of the bumped device **10** with the printed circuit board **20**, completing the electrical circuit between the conductive leads **22** and the die **14**.

[0004] The height and width of the solder bumps **12** on the bumped device **10** are not precisely uniform. Variation of the solder bump height and width depends on several factors, including variation in size of the original unattached solder balls, variation in the sizes of the ball pads, and differences in the attachment process.

[0005] As the demand for smaller packaging continues, however, CSP reliability concerns arise. For example, using typical manufacturing methods and solders, the nominal variation between the tallest and shortest balls (shown as the distance d on FIG. 1) is presently about 60 microns (μm). Therefore, when the device **10** is placed on a flat surface resting on the solder balls, the three tallest balls or bumps define the seating plane of the device, and the smaller balls do not touch the corresponding contact pads of the printed circuit board or test interposer.

[0006] During assembly, and in some cases during testing, a moderate compression force may be applied to the bumped device **10** to drive the outer surfaces **16** of the solder balls **12** into contact with the contact pads **18** of the printed circuit board or test interposer **20**. Typically, the compression force needed to bring the solder bumps into contact with the contact pads varies between 30 grams and 2000 grams depending upon the manufacturing or test process involved. The applied compression force should be kept to a minimum, however, because larger forces may damage the circuitry of the die **14**, the CSP solder balls, or the test interposer.

[0007] One approach to the problem is to mount the contact pads **18** of the test interposer **20** on micro-springs.

As the tallest solder bumps engage the micro-spring mounted contact pads, the micro-springs are compressed, allowing the shorter solder balls to engage the corresponding contact pads. Numerous micro-spring contact pad models are available as shown and described in Robert Crowley's article in Chip Scale Review published May 1998, p. 37, incorporated herein by reference. Although desirable results may be achieved with such devices, micro-spring mounted contact pads **18** are very expensive, relatively difficult to maintain, and may excessively damage the solder ball itself.

[0008] During assembly of the bumped device **10** with the printed circuit board **20**, some of the shorter solder balls may not solder to their associated contact pads during the reflow process. In the past, to increase the numbers of solder balls making contact with the contact pads during reflow, the volume of the solder balls was increased. As packaging sizes and pitch requirements continue to decrease, however, the volume of the solder balls must be reduced accordingly, and thus, the percentage of balls that will not attach to the contact pads during reflow increases. Again, if considerable force is applied during assembly, the CSP or the printed circuit board **20** may be damaged.

SUMMARY OF THE INVENTION

[0009] The present invention is directed toward apparatus and methods for substantial planarization of solder bumps for use in, for example, testing and fabrication of chip scale packages, bumped die, and other similar devices. In one embodiment, an apparatus in accordance with the invention includes a planarization member engageable with at least some of the plurality of outer surfaces, and a securing element engageable with the bumped device to securely position the bumped device during engagement with the planarization member. During engagement with the at least some outer surfaces, the planarization member applies a planarization action on one or more of the outer surfaces to substantially planarize the plurality of outer surfaces. In one embodiment, the planarization member includes a cutting tool and the planarization action comprises a milling action. In another embodiment, the planarization member includes a heated platen and the planarization action comprises a thermo-mechanical deformation action. In yet another embodiment, the planarization member includes an abrasive surface and the planarization action comprising a grinding action. Alternately, the planarization member includes a chemical solution and the planarization action comprises a chemical reaction. In yet another embodiment, the planarization member includes a solder deposition device and the planarization action comprises a solder deposition.

[0010] Alternately, an apparatus may include a planarization gauge that measures a planarization condition of the outer surfaces. The planarization gauge may measure the planarization condition before or after the planarization member is engaged with the outer surfaces.

[0011] In a further embodiment, an apparatus includes a load device engageable with at least one of the bumped device or the planarization member to urge the at least some outer surfaces of the bumped device into engagement with the planarization member. The planarization member applies a planarization action on one or more of the plurality of outer surfaces to substantially planarize the plurality of outer surfaces.

[0012] In one embodiment, the planarization member includes a substantially flat surface and the load device includes a mass having a weight that urges the at least some outer surfaces into engagement with the flat surface to mechanically flatten the surfaces. In another embodiment, the load device includes a fixed surface and a pressurizable vessel, a pressure in the pressurizable vessel urging the bumped device away from the fixed surface and into engagement with the planarization member. In yet another embodiment, the load device includes a press engageable with the bumped device. In still another embodiment, the load device includes a centrifuge engageable with the planarization member.

BRIEF DESCRIPTION OF THE DRAWINGS

[0013] FIG. 1 is a side elevational view of a bumped device engaged with a printed circuit board in accordance with the prior art.

[0014] FIG. 2 is a side elevational view of the bumped device of FIG. 1 engaged with a planarization apparatus in accordance with an embodiment of the invention.

[0015] FIG. 3 is a side elevational view of the bumped device engaged with the printed circuit board of FIG. 1 following substantial planarization of the bumps in accordance with the invention.

[0016] FIG. 4 is a side elevational view of the bumped device of FIG. 1 engaged with a device having protruding contacts.

[0017] FIG. 5 is a side elevational view of the bumped device of FIG. 1 engaged with a planarization apparatus in accordance with an alternate embodiment of the invention.

[0018] FIG. 6 is a side elevational view of the bumped device of FIG. 1 engaged with an alternate embodiment of a planarization apparatus in accordance with the invention.

[0019] FIG. 7 is a side elevational view of an alternate embodiment of a planarization apparatus in accordance with the invention.

[0020] FIG. 8 is a side elevational view of another alternate embodiment of a planarization apparatus in accordance with the invention.

[0021] FIG. 9 is a side elevational view of yet another alternate embodiment of a planarization apparatus in accordance with the invention.

[0022] FIG. 10 shows a partial cross-sectional view of still another embodiment of a planarization apparatus in accordance with the invention.

DETAILED DESCRIPTION OF THE INVENTION

[0023] The following description is generally directed toward apparatus and methods for substantial planarization of solder bumps for use in, for example, testing and fabrication of chip scale packages, bumped die, and other similar devices. Many specific details of certain embodiments of the invention are set forth in the following description and in FIGS. 2-10 to provide a thorough understanding of such embodiments. One skilled in the art, however, will understand that the present invention may have additional

embodiments, or that the present invention may be practiced without several of the details described in the following description.

[0024] FIG. 2 is a side elevational view of a bumped device 10 engaged with a planarization apparatus 100 in accordance with an embodiment of the invention. In this embodiment, the planarization apparatus 100 includes a rotating cutting head 102 with a plurality of cutting blades 104. A securing element 106 having a recess 108 adapted to receive the bumped device 10 is engaged with the bumped device 10 to secure the bumped device 10 in position during engagement of the solder balls 12 with the cutting head 102. A planarization gauge (or sensor) 109 is positioned proximate the bumped device 10 to measure (or sense) a planarization condition of the outer surfaces 16 of the solder balls 12.

[0025] As used throughout the following discussion, the term “bumped device” refers not only to the bumped die depicted in FIG. 2, but also to a wide variety of microelectronics devices having solder bumps, including CSP’s, flip-chips, ball grid array (BGA) packages, and micro-BGA packages. Furthermore, the term bumped device is intended herein to include multiples or combinations of bumped devices, such as an entire wafer of bumped dice prior to die singulation, or an entire handling tray containing multiple bumped packages.

[0026] In operation, the securing element 106 secures the bumped device 10 in position for engagement of the bumped device 10 with the cutting head 102. As the cutting head 102 is moved along the bumped device 10 (or vice versa), the cutting blades 104 rotate (as indicated by arrow w) and engage the outer surfaces 16 of the tallest solder bumps 12. The cutting blades 104 perform a planarization action (i.e. subtractive cutting or milling) on the outer surfaces 16 of one or more of the bumps 12. After engagement of the bumped device 10 with the planarization member 100, the gauge 109 may be used to check the outer surfaces 16, 16a to determine whether the solder balls 12 are all approximately the same height. If the outer surfaces are not planarized to the desired tolerance, the planarization apparatus 100 may be re-engaged with the outer surfaces 16, 16a one or more times until the balls are substantially planarized.

[0027] The terms “planarized” and “planarization” are used throughout this discussion to refer to the fact that the solder balls 12 are made to be approximately the same height—that is to say, the solder balls project from the bumped device by approximately the same distance or thickness. It is not intended to imply that the outer surfaces 16 of all of the solder balls 12 are made flat. As shown in FIG. 2, the planarization apparatus 100 need not engage all of the solder balls 12, and solder balls of different heights are engaged to different degrees. The actual number of solder balls engaged by the planarization apparatus 100 will depend upon the height variation of the balls of the array. Thus, some of the outer surfaces 16a of the solder balls 12 may be flattened, and some will remain rounded. Following application of the planarization action, the plurality of solder balls on the bumped device will be substantially (i.e. approximately) the same height, a condition referred to as “substantially planarized.”

[0028] In an alternate embodiment, as shown in FIG. 2, a planarization member 100A includes a cutting tool 103 that

is oriented approximately perpendicular to the die **14**. The cutting tool **103** may be positioned on a controllably driven base (not shown) and may be sized to apply a planarization action on a single solder bump **12**. Thus, rather than flattening a row or group of solder bumps **12** in a batch mode, the cutting tool **103** allows individual solder balls **12** to be selected for milling. The cutting tool **103** could also be used to remove most or all of a damaged ball. The ball could then be replaced by installation of a pre-formed ball, or by successive deposition of layers of solder using a solder deposition process, as described more fully below.

[0029] One may note that the planarization gauge **109** is depicted in **FIG. 2** as being an optical device that senses the planarity of the outer surfaces **16**, **16a**, such as the type of laser-based gauges disclosed in U.S. Pat. No. 5,663,797 to Sandhu for detecting the endpoint in chemical-mechanical polishing of semiconductor wafers. The gauge **109**, however, may be of any type that is suitable for detecting the heights of the solder bumps, including feeler gauges that physically contact the solder bumps or non-contacting capacitive-type height gauges. Alternately, the planarization gauge **109** may be incorporated into either the planarization member **100**, **100A** or the securing element **106**, or by proper control of the planarization member and securing element, the gauge may be eliminated.

[0030] It should be noted that the gauge **109** could measure all the balls **12** on the package **10** and then the planarization member **100**, **100A** could be directed to only mill off the “tallest” balls. The balls chosen to receive the planarization action could be determined by, for example, a software program. The software program could accept input signals from the gauge **109** and transmit control signals to a controller which controllably positions the planarization member **100**, **100A** to act on the tallest solder balls **12**, thus substantially planarizing the solder balls in a fully-automated, controlled fashion.

[0031] **FIG. 3** is a side elevational view of the bumped device **10** engaged with the printed circuit board **20** of **FIG. 1** following substantial planarization of the outer surfaces **16**, **16a**. After engagement with the planarization apparatus **100**, most or all of the outer surfaces **16**, **16a** are in contact with the corresponding contact pads **18** on the printed circuit board **20**.

[0032] An advantage of substantially planarizing the outer surfaces **16**, **16a** of the bumped device **10** is that testing of the die **14** is significantly enhanced. Because the solder balls **12** are brought into contact with the contact pads **18** with minimal applied force, reliable testing of the die may be achieved without damaging the circuitry of the die.

[0033] Another advantage of substantially planarizing the outer surfaces of the solder bumps is that expensive micro-spring contact devices are eliminated. Significant cost and maintenance savings may be realized using the relatively simple, economical planarization member compared with the purchase or fabrication of a test interposer having micro-spring mounted contact devices.

[0034] Yet another advantage is realized when the substantially planarized outer surfaces **16a** are engaged with a device **20a** (e.g. printed circuit board, test interposer, etc.) having protruding or pedestal-shaped contacts **118a**. **FIG. 4** shows the bumped device **10** having substantially planarized

solder bumps **12** engaged with a test interposer **20a**-having protruding contacts **18a**. Without planarization of the solder bumps **12**, the height h of the protruding contacts **18a**, would need to be on the order of $60\ \mu\text{m}$ —the nominal variation between the tallest and shortest balls without planarization (shown as distance d on **FIG. 1**).

[0035] When the outer surfaces of the solder balls are substantially planarized, however, the variation of solder ball heights is reduced so that the required pedestal contact height is reduced accordingly. With the solder balls substantially planarized, the required height of the protruding contacts **18a** on the test interposer **20a**, for example, is reduced to about $20\ \mu\text{m}$, which is just enough to penetrate a layer of surface oxides on the solder balls for testing of the bumped device **10**. By reducing the height requirement of the protruding contacts, substantial savings in manufacturing costs of the protruding contacts is achieved.

[0036] **FIG. 5** is a side elevational view of the bumped device **10** of **FIG. 1** engaged with an alternate embodiment of a planarization apparatus **200** in accordance with the invention. In this embodiment, the planarization apparatus **200** includes a heated platen **202** having a substantially flat surface **204** engageable with the outer surfaces **16** of the solder balls **12**, and a securing element **206** having an aperture **208** therethrough. The bumped device **10** is securely engaged within the aperture **208** so that the securing element **206** secures and positions the device during engagement with the heated platen **202**.

[0037] As the heated platen **202** is engaged with the outer surfaces **16**, the outer surfaces are heated by the flat surface **204** of the platen. Depending upon the temperature of the platen **202**, and the period of contact with the platen, the outer surfaces may be softened and mechanically flattened by the flat surface **204**, or may be heated until the solder sublimates. In either case, these thermo-mechanical actions performed by the heated platen **202** on the solder balls **12** substantially planarize the outer surfaces **16a** to an approximately uniform height.

[0038] One may note that if temperature of the platen **202** is high enough to liquify the solder, then the platen **202** is preferably made of a material that the solder will not wet to. Also, if the platen **202** is removed from the ball while the ball is still in a liquid state, then the surface tension of the ball may cause the ball to reform into its original undesirable spherical shape. Thus, if the platen **202** temperature is sufficient to liquify the solder ball **12**, then after the ball has been liquified and mechanically reformed, it is preferable that the platen **202** temperature be reduced while the platen remains in contact with the ball **12** until the solder ball solidifies into a substantially planarized shape.

[0039] Although the heated platen **202** is shown in **FIG. 5** as only contacting four of the solder balls **12**, it is apparent that the platen may be made as large or as small as desirable. The platen may, for example, be coextensive with all the balls of the bumped device **10**. Alternately, the heated platen may be configured to contact only one ball (or one row) at a time, such as by using a roller, a blade, a squeegee, or other configuration.

[0040] Numerous alternate embodiments of planarization apparatus are conceivable. For example, in one alternate embodiment, the planarization apparatus **200** includes a

grinding member **202** having an abrasive surface **204** engageable with the outer surfaces **16** of the solder bumps **12**. In this embodiment, the grinding member **202** is laterally moveable (indicated in **FIG. 4** by the double-headed arrow **h**) with respect to the solder bumps **12**. As the grinding member **202** is moved, the abrasive surface **204** performs a grinding action on one or more of the bumps **12**, thereby substantially planarizing the outer surfaces **16a**.

[0041] Alternately, the grinding member may rotate with respect to the bumps in a manner similar to the chemical-mechanical polishing (CMP) devices for planarization of silicon wafers, including, for example, the types disclosed in U.S. Pat. No. 5,738,567 to Manzonie and Akram. The abrasive surface **204** may be used with a polishing solution that helps to dissolve the outer surfaces of the solder bumps, or an abrasive slurry that assists in the physical removal of material from the outer surfaces. Furthermore, planarization apparatus in accordance with the invention may be used to planarize the solder balls of flip-chip devices while still in whole wafer form, prior to die singulation of the wafer.

[0042] In another alternate embodiment, the planarization apparatus **200** includes a reactive member **202** having a chemically-coated or wetted surface **204**. As the wetted surface **204** is engaged with the outer surfaces, a chemical action is performed on the solder bumps which dissolves the outer edges of the tallest bumps, making the bumps approximately the same height and substantially planarizing the outer surfaces **16**, **16a**. Suitable chemicals for coating or wetting the surface **204** for chemically reacting with the solder balls are known in the industry, as discussed in greater detail below. Many alternate embodiments of securing elements are available, including, for example, those having recesses (**FIG. 1**), apertures (**FIG. 2**), pinching mechanisms, clamping mechanisms, or suction mechanisms. In general, all types of securing elements that securely position the bumped device during engagement with the planarization member are acceptable.

[0043] **FIG. 6** is a side elevational view of the bumped device **10** of **FIG. 1** engaged with an alternate embodiment of a planarization apparatus **300** in accordance with the invention. In this embodiment, the planarization apparatus **300** has a pair of contact posts **302** that contact the outer surfaces **16** of the solder balls **12**, and a solder deposition device **304**. The solder deposition device **304** deposits a solder buildup layer **308** on selected solder balls **12**. A securing element **306** pinches the substrate **14** of the bumped device **10** to securely position the device during engagement with the solder deposition device **304**.

[0044] In operation, the contact posts **302** systematically contact the outer surfaces **16** of at least some of the solder balls **12** to determine the highest solder balls **12**. The highest solderballs then define a seating plane **307**. For example, for a two-dimensional array of solder balls, the seating plane **307** may be defined by the three tallest balls or, if desired, from the single tallest ball. Similarly, for a single row of solder balls, the seating plane **307** may be determined from the two tallest balls or the single tallest ball. Once the seating plane **307** is established, the solder deposition device **304** is positioned over each of the shorter solder balls and deposits one or more buildup layers of solder **308** on each of the shorter balls; The buildup layers **308** are successively applied until the height of each solder ball reaches the

seating plane **307** through an "additive" planarization process, and the outer surfaces are substantially planarized.

[0045] One may note that the process involving definition of the seating plane **307** may be employed equally well with the planarization apparatus that employ "subtractive" planarization actions, such as the rotating cutter or the heated platen. Furthermore, through combination of various "subtractive" and "additive" processes, damaged balls may be partially or wholly removed and replaced until the solder balls **12** are substantially planarized. Thus, the inventive apparatus and processes may be used to rework or repair bumped devices **10** with missing or damaged solder balls.

[0046] Although the planarization apparatus **300** is shown in **FIG. 6** as having two contact posts **302**, it should be recognized that many alternative ways of defining the seating plane **307** exist. For example, the planarization apparatus **300** may have only a single contact post that is used to sample the heights the solder bumps, or may have a contact post for each of the solder bumps on the bumped device **10**.

[0047] Also, the planarization apparatus **300** may have a single, adjustably positionable solder deposition device **304** as shown in **FIG. 6**, or many solder deposition devices, such as one solder deposition device per solder bump. The solder deposition device **304** may include a solder jet, or a solder ball bumper, or other suitable device. Representative, commercially-available devices include the drop-on demand solder jet systems from MPM Corporation of Franklin, Mass., or the solder ball bumper Model SB²M from Packaging Technologies, GmbH of Germany.

[0048] It may also be noted that the seating plane **307** may be defined at any desired intermediate level that is somewhere between the highest and lowest bumps. In that case, the solder deposition device **304** could be used to build up the heights of the shorter solder bumps **12**, while another planarization member (e.g. cutting head, heated platen, etc.) could be used to reduce the heights of the taller solder bumps until all of the solder bumps are substantially planarized.

[0049] **FIG. 7** is a side elevational view of an alternate embodiment of a planarization apparatus **400** in accordance with the invention. This embodiment of the planarization apparatus **400** is suitable for use with, for example, a bumped device **10a** that is capable of withstanding a moderate or larger compression load without sustaining damage. The planarization apparatus **400** includes a planarization chuck **402** having a substantially flat surface **404**, and a retaining mass **406** engaged with the substrate **14** of the bumped device **10a**.

[0050] In operation, the bumped device **10a** is positioned with the solder balls **12** facing the flat surface **404** of the planarization chuck **402**, and the retaining mass **406** is engaged onto the bumped device **10a**. The retaining mass **406** secures the bumped device **10a** into engagement with the planarization chuck **402**, and the weight of the retaining mass **406** compresses the solder balls **12** against the flat surface **404**, flattening the outer surfaces **16** of some or all of the balls, particularly the tallest balls. The compression caused by the weight of the retaining mass mechanically deforms the outer surfaces **16a**, thereby substantially planarizing the outer surfaces **16**, **16a** of the solder balls. Thus, the planarization member **400** advantageously provides the benefits of substantial planarization of the solder balls using a simple, inexpensive, and easily maintainable system.

[0051] It should be noted that the compression force that flattens the outer surfaces **16a** of the solder balls can be generated in many different ways. FIG. 8, for example, shows an alternate embodiment of a planarization apparatus **500** having a pressure plate **532** engaged against the bumped die **10a** opposite from the planarization chuck **402**. A pressurizable vessel **534** is positioned above the pressure plate **532**, and a fixed wall **536** is positioned over the pressurizable vessel **534**. As the pressurizable vessel **534** is inflated, the pressure in the vessel forces the pressure plate **532** downward against the bumped die **10a**, compressing the solder balls **12** against the flat surface **404** and flattening the outer surfaces **16a**.

[0052] In another embodiment, the pressure plate **532** is removed, and the pressurizable vessel **534** engages the bumped die **10a** directly to apply the compression force. Alternately, the compression force could be generated by any number of devices which are commonly known in the industry, including, for example, a press, a motor and mechanical linkage, or other devices.

[0053] FIG. 9 is a side elevational view of yet another embodiment of a planarization apparatus **600** in accordance with the invention. In this embodiment, the planarization apparatus **600** includes a planarization chuck **602** having a substantially flat surface **604**, and a centrifuge **610**. A pair of securing members (or clips) **606** engage and secure the bumped device **10a** in position on the planarization chuck **602** with the solder balls **12** of the bumped device **10a** engaged with the flat surface **604**.

[0054] In operation, the centrifuge **610** is rotated as depicted by arrow R. The rotation of the centrifuge generates a centrifugal force that compresses the bumped device **10a** against the planarization chuck **602**. During acceleration (and deceleration) of the centrifuge **610**, the securing members **606** secure the bumped device **10a** in position on the planarization chuck **602**. As the rotational velocity of the centrifuge **610** increases, a centrifugal force begins to press some or all of the solder bumps **12** into the flat surface **604**, substantially flattening the outer surfaces **16a** against the flat surface **604**. As shown in FIG. 8, one or more planarization chucks **602** may be disposed within the centrifuge **610** for simultaneously planarizing more than one bumped device **10a**. The centrifuge **610** advantageously eliminates the use of weights, pressurization vessels, or other devices used to generate the compression force.

[0055] FIG. 10 shows a partial cross-sectional view of still another embodiment of a planarization apparatus **700** in accordance with the invention. In this embodiment, the planarization apparatus **700** includes a receptacle **702** having a retaining wall **704**. The retaining wall **704** partially encloses a receiving space **706** that is sized to receiveably engage the bumped device **10**. With the bumped device **10** placed in an inverted position within the receiving space **706**, the retaining wall **704** projects above the outer surfaces **16b** of the tallest solder bumps **12** (shown in dashed lines). A protective layer **740** is disposed on the bumped device **10** within the receiving space **706**, the protective layer **740** at least partially surrounding and encasing the solder bumps **12**. The protective layer **740** includes an upper surface **707**. A reactive solution **750** is disposed within the receiving space **706** on the upper surface **707** of the protective layer **740**, and a planarization gauge **109** is positioned proximate the receptacle **702**.

[0056] In operation, the protective layer **740** is formed so that its thickness is approximately equal to the height of the shortest solder bump **12**. The upper surface **707** thereby defines a seating plane through which the outer surfaces **16b** project. The reactive solution **750** is then deposited into the receiving space **706** to chemically react with and dissolve (i.e. etch) the outer surfaces **16b** of the solder bumps **12**. The protective layer **740** is comprised of one or more materials that are resistive or inert to the reactive solution **750**. As the reactive solution **750** etches the projecting portion of the outer surfaces **16b**, the planarization gauge **109** monitors a planarization condition of the seating plane and outer surfaces (as discussed above). When the outer surfaces **16a** are substantially planar with the upper surface **707**, the reactive solution **750** is removed. The protective layer **740** is then etched or dissolved using a suitable solution or other process (e.g. by heating) that removes the protective layer but does not harm the solder bumps **12**. The heights of the solder bumps **12** on the bumped device **10** are thereby substantially planarized.

[0057] Suitable reactive solutions **750** for etching the solder balls **12** are known, and include, for example, ammonium bifluoride/peroxide, nitric/ferric nitrate acid, nitric/hydrofluoric acid, or a two-step combination of nitric acid followed by ferric chloride. Similarly, suitable materials for the protective layer **740** are widely known.

[0058] The planarization gauge **109** could be incorporated into the receptacle **702**, such as by being disposed within the retaining wall **704**. Alternately, by proper control or calibration of the reactive solution **750** and/or the solder composition, the planarization gauge **109** may be eliminated.

[0059] In an alternate embodiment, the bumped device **10** is re-positioned with the solder bumps **12** projecting downwardly, and the reactive solution **750** is contained in a vat or reservoir below the bumped device **10**. Using a suitable securing element, the bumped device **10** could be controllably lowered (or the reservoir of reactive solution raised) until some or all of the outer surfaces **16**, but at least the outer surfaces **16b** of the tallest solder bumps, come into contact with the reactive solution **750**. The reactive solution **750** then etches and dissolves the outer surfaces that come into contact with the reactive solution, dissolving the outer surfaces and substantially planarizing the solder bumps.

[0060] In this embodiment, the protective layer **740**, the retaining wall **704**, and the planarization gauge **109** may be eliminated. Thus, the benefits of substantial planarization of the solder balls **12** are achieved using a relatively simple, easily maintainable planarization system.

[0061] The above-described embodiments of planarization apparatus, and their equivalents, provide improved testing, manufacture, and packaging of bumped devices by substantially planarizing the outer surfaces of the solder balls. By substantial planarization of the solder bumps, the compression forces needed to engage the solder balls **12** into contact with the contact pads **18** or a test interposer, printed circuit board, or other bumped device are substantially reduced or eliminated, thereby improving reliability and avoiding damage to the bumped device. Expensive alternatives, such as micro-spring contact pads, are eliminated. Another advantage is that substantial planarization of the solder balls improves the engagement of the bumped device

with a device having pedestal or protruding contacts, simplifying the manufacturing and reducing the cost of such devices.

[0062] The detailed descriptions of the above embodiments are not exhaustive descriptions of all embodiments contemplated by the inventor to be within the scope of the invention. Indeed, persons skilled in the art will recognize that certain elements of the above-described embodiments may variously be combined or eliminated to create further embodiments, and such further embodiments fall within the scope and teachings of the invention. It will also be apparent to those of ordinary skill in the art that the above-described embodiments may be combined in whole or in part to create additional embodiments within the scope and teachings of the invention.

[0063] Thus, although specific embodiments of, and examples for, the invention are described herein for illustrative purposes, various equivalent modifications are possible within the scope of the invention, as those skilled in the relevant art will recognize. The teachings provided herein of the invention can be applied to other apparatus and methods for substantial planarization of solder bumps, and not just to the apparatus and methods described above and shown in the figures. In general, in the following claims, the terms used should not be construed to limit the invention to the specific embodiments disclosed in the specification and the claims, but should be construed to include all apparatus and methods that operate under the claims to provide substantially planarized solder bumps. Accordingly, the invention is not limited by the foregoing disclosure, but instead its scope is to be determined by the following claims.

1. An apparatus for substantially planarizing a plurality of outer surfaces of an array of solder bumps attached to a bumped device, comprising:

a planarization member engageable with at least some of the plurality of outer surfaces, the planarization member applying a planarization action on one or more of the plurality of outer surfaces to substantially planarize the solder bumps; and

a securing element engageable with the bumped device to securely position the bumped device during engagement of the planarization member with the outer surfaces.

2. The apparatus of claim 1, further comprising a planarization gauge engageable with at least a portion of the outer surfaces to assess a planarization condition of the solder bumps.

3. The apparatus of claim 1 wherein the planarization member includes a cutting tool and the planarization action comprises a milling action on the one or more outer surfaces.

4. The apparatus of claim 1 wherein the planarization member includes a heated platen and the planarization action comprises a thermo-mechanical deformation action on the one or more outer surfaces.

5. The apparatus of claim 1 wherein the planarization member includes an abrasive surface and the planarization action comprises a grinding action on the one or more outer surfaces.

6. The apparatus of claim 1 wherein the planarization member includes a chemical solution and the planarization action comprises a chemical reaction with the one or more outer surfaces.

7. The apparatus of claim 1 wherein the planarization member includes a solder deposition device and the planarization action comprises a solder deposition on the one or more outer surfaces.

8. The apparatus of claim 7, further comprising a contact member engageable with one or more of the solder bumps to determine a seating plane, the solder deposition device applying the solder deposition on the one or more outer surfaces until the outer surfaces are substantially planarized along the seating plane.

9. The apparatus of claim 1 wherein the securing element includes a retaining wall sized to define a receiving space for receiving the bumped device, further comprising a protective layer disposed within the receiving space and at least partially covering the solder bumps except for the one or more outer surfaces, and wherein the planarization member includes a reactive solution disposed within the receiving space on the protective layer, the planarization action comprising an etching of the one or more outer surfaces by the reactive solution.

10. The apparatus of claim 1 wherein the planarization member includes a reservoir of a reactive solution and the securing element securely positions the bumped device with the solder bumps projecting downwardly toward the reservoir, the planarization action comprising an etching of the one or more outer surfaces by the reactive solution when the one or more outer surfaces are brought into contact with the reactive solution.

11. The apparatus of claim 1 wherein the at least some outer surfaces engageable by the planarization member include the one or more outer surfaces upon which the planarization action is applied.

12. The apparatus of claim 1 wherein the securing element includes a retaining mass positioned on the bumped device and the planarization member includes a substantially flat surface positioned below the bumped device in contact with the at least some outer surfaces, the planarization action comprising a compressive force due to the weight of the retaining mass, the compressive force mechanically flattening the one or more outer surfaces.

13. The apparatus of claim 1, further comprising a load device engageable with at least one of the bumped device or the planarization member to urge the at least some outer surfaces of the bumped device into engagement with the planarization member.

14. The apparatus of claim 13 wherein the load device includes a fixed surface and a pressurizable vessel disposed between the fixed surface and the bumped device, a pressure in the pressurizable chamber urging the bumped device away from the fixed surface and into engagement with the planarization member.

15. The apparatus of claim 13 wherein the securing element includes a retaining clip engageable with a substrate of the bumped device and the planarization member includes a substantially flat surface in contact with the at least some outer surfaces, the load device including a centrifuge engageable with the planarization member, the planarization action comprising a centrifugal force that compresses and mechanically flattens the one or more outer surfaces against the flat surface.

16. An apparatus for approximately planarizing a plurality of solder bumps, comprising:

a planarization member engageable with at least some of the plurality of solder bumps to apply a planarization

action on one or more of the plurality of solder bumps to approximately equalize the heights of the solder bumps on a bumped device; and

a securing element engageable with the bumped device to securely position the bumped device during engagement of the planarization member with the solder bumps.

17. The apparatus of claim 16, further comprising a planarization gauge engageable with at least a portion of the solder bumps to assess a planarization condition of the solder bumps.

18. The apparatus of claim 16, further comprising a load device engageable with at least one of the planarization member or the bumped device to urge the at least some solder bumps into engagement with the planarization member.

19. A method of substantially planarizing an array of solder bumps attached to a bumped device, comprising:

securely positioning the array of solder bumps proximate a planarization member;

engaging the planarization member with at least some of a plurality of outer surfaces of the solder bumps; and

applying a planarization action with the planarization member to one or more of the outer surfaces to substantially planarize the array of solder bumps.

20. The method of claim 19, further comprising sensing at least some of the plurality of outer surfaces to define a seating plane.

21. The method of claim 19, further comprising gauging a planarization condition of the array of solder bumps.

22. The method of claim 21 wherein gauging a planarization condition of the array of solder bumps comprises gauging the planarization condition of the array of solder bumps after engaging the planarization member with at least some of the plurality of outer surfaces of the solder bumps.

23. The method of claim 19 wherein the planarization member has a substantially flat surface and applying a planarization action with the planarization member to one or more of the outer surfaces comprises applying a compressive force with the substantially flat surface to mechanically flatten the one or more outer surfaces.

24. The method of claim 19 wherein the planarization member includes a heated platen and applying a planarization action with the planarization member to one or more of the outer surfaces comprises at least partially thermo-mechanically deforming the one or more outer surfaces with the heated platen.

25. The method of claim 19 wherein the planarization member includes a cutting tool and applying a planarization action with the planarization member to one or more of the outer surfaces comprises milling the one or more outer surfaces with the cutting tool.

26. The method of claim 19 wherein the planarization member includes a chemically reactive solution and applying a planarization action with the planarization member to one or more of the outer surfaces comprises dissolving the one or more outer surfaces with the chemically reactive solution.

27. The method of claim 19 wherein applying a planarization action with the planarization member to one or more of the outer surfaces comprises applying a planarization action

with the planarization member to the at least some outer surfaces engaged with the planarization member.

28. The method of claim 19, further comprising engaging a load member with at least one of the bumped device or the planarization member to urge the at least some outer surfaces into engagement with the planarization member.

29. The method of claim 19, further comprising forming a protective layer at least partially surrounding the solder bumps.

30. A method of substantially planarizing an array of solder bumps attached to a bumped device, comprising adjusting the thickness of at least some of the solder bumps so that all of the solder bumps in the array project from the bumped device by substantially the same distance.

31. The method of claim 30, further comprising securing the position of the bumped device during engagement of the planarization member with the at least some solder bumps.

32. The method of claim 30, further comprising gauging a planarization condition of the array of solder bumps.

33. The method of claim 30 wherein adjusting the thickness of at least some of the solder bumps comprises milling the at least some solder bumps with a cutting tool.

34. The method of claim 30 wherein adjusting the thickness of at least some of the solder bumps comprises thermo-mechanically deforming the at least some solder bumps.

35. The method of claim 30 wherein adjusting the thickness of at least some of the solder bumps comprises grinding the at least some solder bumps with an abrasive.

36. The method of claim 30 wherein adjusting the thickness of at least some of the solder bumps comprises dissolving a portion of the at least some solder bumps with a chemical solution.

37. The method of claim 30 wherein adjusting the thickness of at least some of the solder bumps comprises mechanically flattening the at least some solder bumps.

38. The method of claim 30 wherein adjusting the thickness of at least some of the solder bumps comprises depositing a volume of solder on the at least some solder bumps.

39. A bumped device having an array of substantially planarized solder bumps created by a method comprising:

securely positioning the array of solder bumps proximate a planarization member;

engaging the planarization member with at least some of a plurality of outer surfaces of the solder bumps; and

applying a planarization action with the planarization member to one or more of the outer surfaces to substantially planarize the array of solder bumps.

40. The bumped device of claim 39 wherein the method further comprises gauging a planarization condition of the array of solder bumps.

41. The bumped device of claim 39 wherein applying a planarization action with the planarization member to one or more of the outer surfaces comprises milling the one or more outer surfaces with a cutting tool.

42. The bumped device of claim 39 wherein applying a planarization action with the planarization member to one or more of the outer surfaces comprises thermo-mechanically deforming the one or more outer surfaces with a heated tool.

43. The bumped device of claim 39 wherein applying a planarization action with the planarization member to one or

more of the outer surfaces comprises grinding the one or more outer surfaces with an abrasive.

44. The bumped device of claim 39 wherein applying a planarization action with the planarization member to one or more of the outer surfaces comprises dissolving a portion of the one or more outer surfaces with a reactive solution.

45. The bumped device of claim 39 wherein applying a planarization action with the planarization member to one or

more of the outer surfaces comprises mechanically flattening the one or more outer surfaces.

46. The bumped device of claim 39 wherein applying a planarization action with the planarization member to one or more of the outer surfaces comprises depositing a volume of solder on the one or more outer surfaces.

* * * * *