

Feb. 15, 1966

M. I. GLASS ETAL

3,235,259

TOY BOXERS

Filed June 14, 1963

4 Sheets-Sheet 1

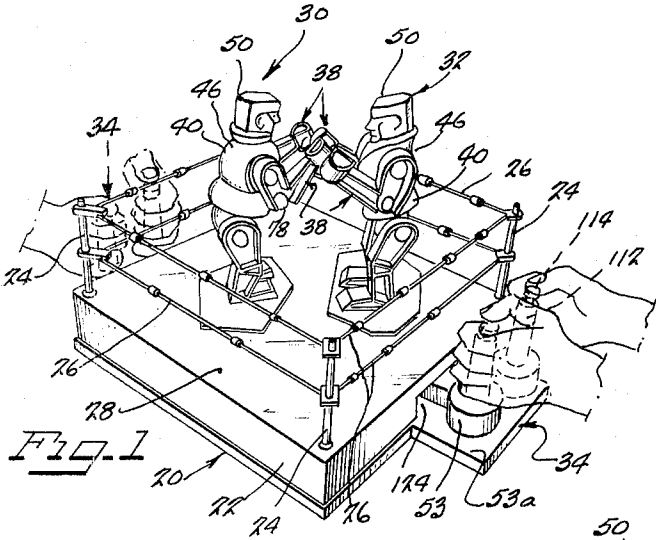

Fig. 1

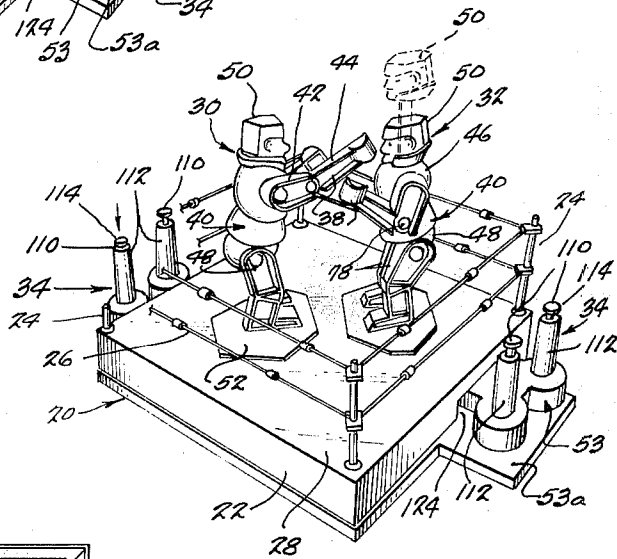

Fig. 2

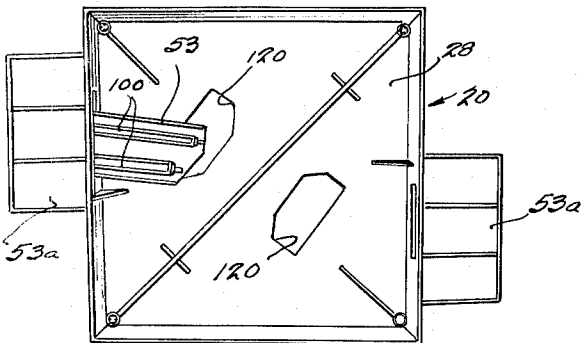

Fig. 3

Inventors
 MARVIN I. GLASS
 HARRY DISKO
 BURTON G MEYER
 By Anderson, Suedke,
 Fitch, Even + Tabin Attys

Feb. 15, 1966

M. I. GLASS ET AL

3,235,259

TOY BOXERS

Filed June 14, 1963

4 Sheets-Sheet 2

Fig. 4

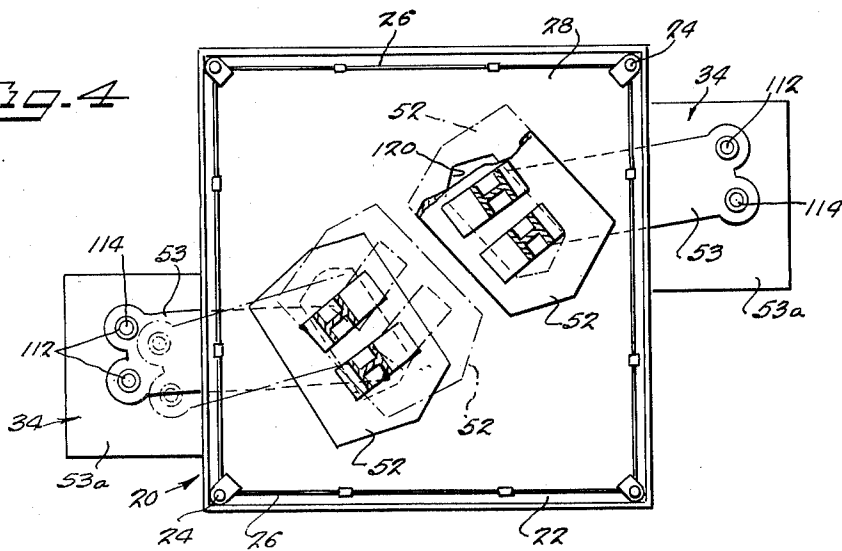

Fig. 5

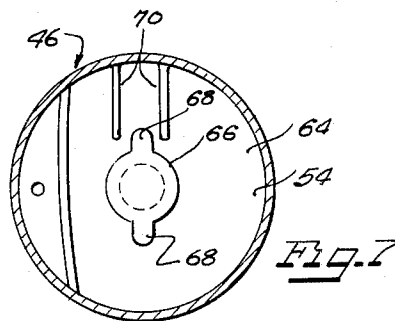
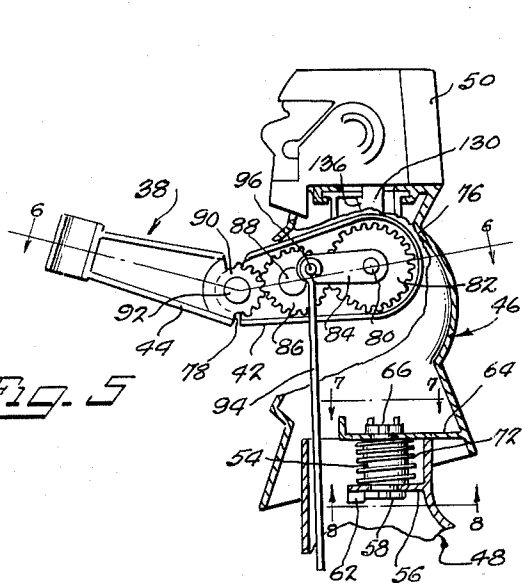

Fig. 7

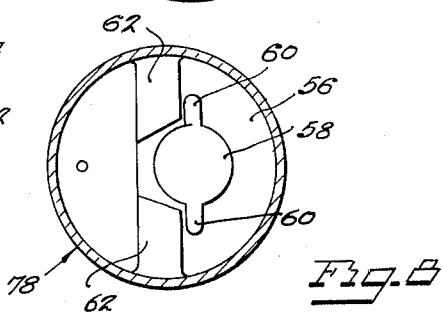

Fig. 8

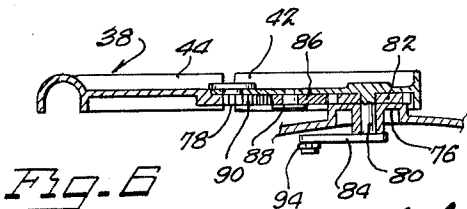

Fig. 6

Inventors
 MARVIN I GLASS
 HARRY DISKO
 BY BURTON C MEYER

Anderson, Suedepa
 Fulch, Even + Tabin

Attys

Feb. 15, 1966

M. I. GLASS ETAL

3,235,259

TOY BOXERS

Filed June 14, 1963

4 Sheets-Sheet 3

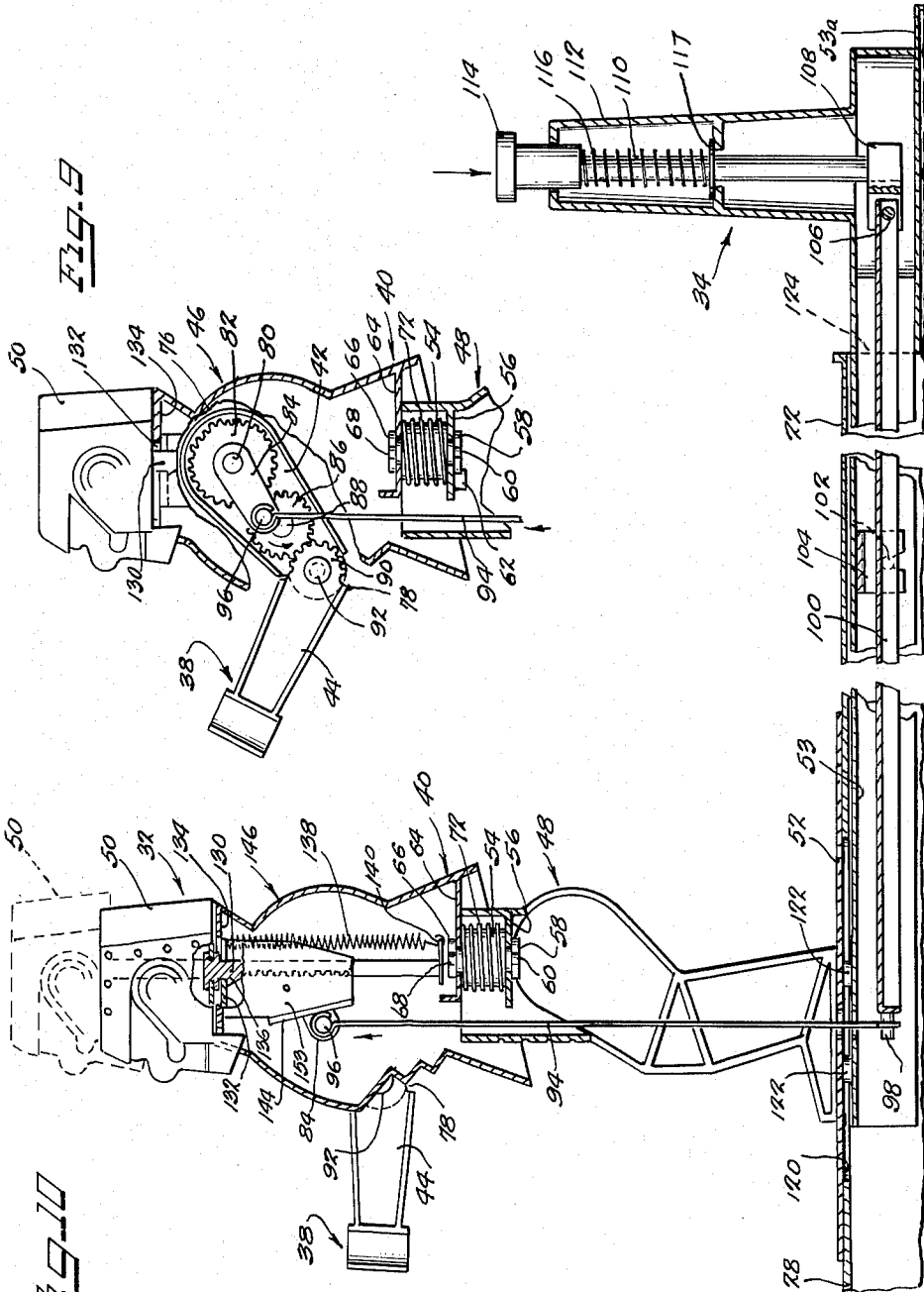

INVENTORS
 MARVIN I. GLASS
 HARRY DISKO
 BY BURTON C. MEYER

Anderson, Suedoko
 Futch, Evem + Tabin ATTYS

Feb. 15, 1966

M. I. GLASS ETAL

3,235,259

TOY BOXERS

Filed June 14, 1963

4 Sheets-Sheet 4

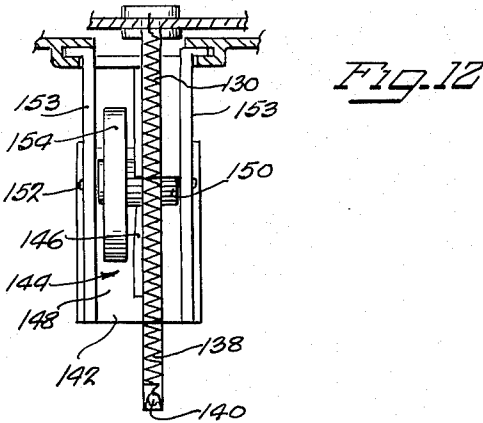
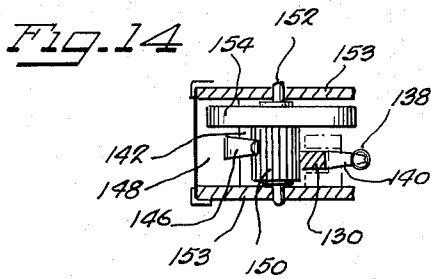
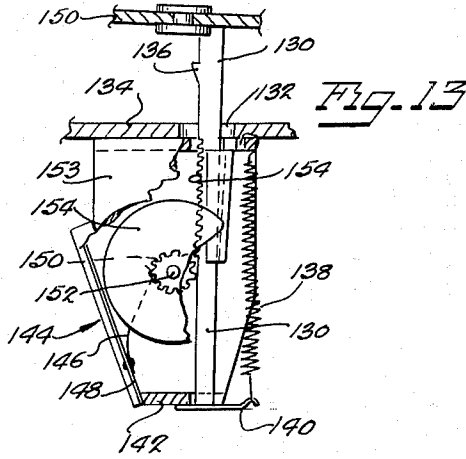
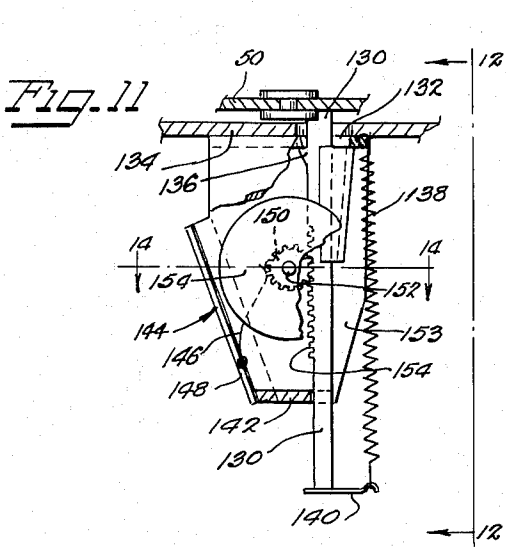

INVENTORS
 MARVIN I GLASS
 HARRY DISKO
 BURTON G MEYER
 BY *Anderson, Suedelka*
 Fitch, Even & Tabin *Attys*

1

3,235,259

TOY BOXERS

Marvin I. Glass, Chicago, Harry Disko, Park Ridge, and
Burton C. Meyer, Chicago, Ill., assignors to Marvin
Glass & Associates, Chicago, Ill., a partnership
Filed June 14, 1963, Ser. No. 288,029
1 Claim. (Cl. 273-85)

This invention relates to a toy and, more particularly, to a toy boxing game.

Various types of boxing games have been known heretofore wherein a pair of opposing fighter figures were manipulated by the players. The present invention is particularly directed to a game of this type including novel features of construction and action so as to make the game more attractive and interesting.

It is the primary object of this invention to provide a new and amusing toy in the form of a novel boxing game manually operated by opposing players.

Another object is provision of a new and amusing boxing game wherein opposing players manipulate toy robot fighters to provide movement and punching action for the fighters.

A further object is provision of a new and amusing boxing game wherein upon being hit in a particular manner the losing fighter's head pops up. Another related object is provision of a noisemaker operable upon the head popping up to produce an appropriate sound.

These and other objects of the invention are more particularly set forth in the following detailed description and in the accompanying drawings of which:

FIGURE 1 is a fragmentary perspective view of the boxing game of this invention wherein opposing players' hands are positioned on control members for fighters whose arms are in a normal guard position;

FIGURE 2 is a fragmentary perspective view, similar to FIGURE 1, but with one of the fighters about to land a punch on the other fighter's head to release the head so that it pops up to the position indicated by dotted lines;

FIGURE 3 is a bottom view of the game, with parts removed for clearer illustration;

FIGURE 4 is an enlarged, top view of the game, with upper portions of the fighters broken away and in section for clearer illustration, and with a displaced position of the mount and control member for one of the fighters shown in dotted line;

FIGURE 5 is an enlarged, fragmentary side view of the upper portion of a fighter, with parts broken away and in section for clearer illustration, and with an arm extended while punching;

FIGURE 6 is a sectional view taken generally along the line 6-6 in FIGURE 5;

FIGURE 7 is an enlarged sectional view taken generally along the line 7-7 in FIGURE 5;

FIGURE 8 is an enlarged sectional view taken generally along the line 8-8 in FIGURE 5;

FIGURE 9 is an enlarged, fragmentary side view of the upper portion of a fighter, with parts broken away and in section for clearer illustration, and with an arm in normal guard position;

FIGURE 10 is a side view of a fighter and its mount and control member, with parts broken away and removed for clearer illustration, and with the popped up position of the fighter's head indicated in dotted line;

FIGURE 11 is a fragmentary view of a mechanism for causing the head to pop up and for operating a noisemaker, the mechanism being in position corresponding to normal position of the head as shown in solid line in FIGURE 10;

2

FIGURE 12 is a fragmentary rear view of the mechanism taken generally along the line 12-12 in FIGURE 11;

FIGURE 13 is a view similar to FIGURE 11 but with the mechanism in position corresponding to the popped up position of the head; and

FIGURE 14 is a sectional view taken generally along the line 14-14 in FIGURE 11.

The invention is, in brief, directed to a toy in the form of a boxing game manually operable by opposing players who attempt to move their fighters to avoid being punched, while hitting the opponent's fighter in a manner to cause the head of the opponent's fighter to pop up. The fighters are in the form of robots having twistable torsos and upon popping up of the head the robot appears to be flying apart to the accompaniment of a suitable sound. Arms of the fighters are articulated for punching movement in a clever and more realistic manner.

With initial reference to FIGURES 1 and 2, the toy includes a support in the form of a boxing ring 20 including a raised platform 22 on which are mounted suitable corner posts 24 and ropes 26 which enclose a generally horizontal surface providing a base 28. A pair of opposed fighters 30 and 32 are in the form of mechanical robots positioned on the base 28. Actuating means for the fighters 30 and 32 are each in the form of a mount and control member 34, for moving the associated fighter about the boxing ring 20 and actuating its arms 38 to punch at the opposing fighter. Each arm swings with respect to the fighter's torso 40 and is articulated so that an upper arm 42 and a forearm 44 move relative to each other when punching. A torso upper portion 46 may move relative to a hip and leg lower portion 48 to more closely simulate body movement upon being hit. Each fighter has a head 50, and upon the head being hit in a particular manner by the opposing fighter, it pops up from a normal position as shown by solid lines in FIGURE 2, to an extended position as indicated by dotted lines in FIGURE 2. As the head pops up, a suitable noisemaker (FIGURES 11-14) is actuated to provide a suitable accompanying sound, herein a zinging sound as though the robot were flying apart.

The fighters 30 and 32 may be identical, and one of the fighters is shown in detail in FIGURES 5-10. The lower torso portion 48 of the fighter includes hips and legs which are rigidly mounted on a supporting plate 52. The plate 52 is rigidly connected with a mount portion 53 of the mount and control member 34. An outer end of each mount is slidably seated on a flange 53a of the ring 20. The upper torso portion 46 is mounted on the lower torso portion for slight twisting movement about a vertical axis and for back and forth movement transversely of this axis. As may best be seen in FIGURES 5, 7 and 8, such movement is provided by means of a generally vertical shank 54 having a lower end extending through a web 56 (FIGURE 8) of the lower torso portion 48. The shank 54 has a lower head 58 engaging the lower face of the web 56 with horizontal fingers 60 extending in a diametrically opposite directions and proximate stubs 62 depending from the web 56 on opposite sides of the head 58 to permit but very limited pivotal movement of the shank. The upper end of the shank 54 extends through a horizontal web 64 (FIGURE 7) of the upper torso portion 46 and has an upper head 66 with a pair of generally horizontal fingers 68 extending in diametrically opposite directions and one received between a pair of generally parallel ribs 70 extending upwardly from the web 64 and embracing and normally spaced from an adjacent finger 68 so that the upper torso portion 46 may rotate slightly as limited by engagement of either of the ribs 70 with the adjacent finger. A

spiral compression spring 72 encircles the shank 54 and has opposite ends seated, respectively, on the webs 56 and 64 to seat these webs firmly against the adjacent shank heads 58 and 66, respectively, so that the upper torso portion 46 is firmly secured to the lower torso portion 48 to provide the aforementioned relative movement between torso portions.

In the illustrated embodiment, each fighter 30 and 32 has a pair of articulated arms 38, as may best be seen in detail in FIGURE 5, 6, 9 and 10. Each arm 38 includes the upper arm 42 articulated on a shoulder portion 76 of the upper torso 46, and more particularly pivotable about a generally horizontal axis. Each arm further includes a forearm 44 articulated about an elbow portion 78, and more particularly pivoted about a horizontal axis. The actuating means may be operated to cause the arm to move so that in throwing a punch the upper arm 42 and the forearm 44 concurrently pivot upwardly about their respective axes in a manner closely simulating throwing an upper cut. More particularly, the upper arm 42 is fixed to a stub shaft 80 which is journaled in the shoulder portion 76 of the torso for rotation about the pivotal axis of the upper arm. The upper arm 42 is fixed to the outer end of shaft 80. A gear 82 is fixed to and integral with the body 46 at a position adjacent the inner side of the upper arm 42, and a lever 84 is disposed within the upper torso portion 46 and is fixed to an inner end of the rotatable shaft 80. Within the arm 42 is an idler gear 86 mounted for rotation about a stub shaft 88 fixed to the upper arm 42, with gear 86 engaging the fixed gear 82. The idler gear 86 is drivingly meshed with a gear segment 90 integral with the forearm 44 at the elbow portion 78 and concentric with a horizontal axle 92 pivotally connecting the forearm 44 with the upper arm 42. Thus, as the lever 84 pivots upwardly the upper arm 42 fixed to shaft 80 is moved upwardly, thereby causing the idler gear 86 to rotate counterclockwise, the segment 90 is rotated clockwise and rotates the forearm 44 in a clockwise direction and outwardly from the upper arm. The gearing is such that as the upper arm 42 moves upwardly the forearm 44 snaps outwardly to throw a quick punch at the opposing fighter.

The actuating means includes a generally vertical link 94 within the torso and pivoted at its upper end to the forward end of the lever 84, as by a pin 96, and having a lower end pivoted to a pin 98 on an inner end of an actuating bar 100. Intermediate its ends the bar 100 carries oppositely directed horizontal pins 102 journaled in depending ears 104 of the mount 53. An outer end of the bar 100 is pivoted about a pin 106 extending from a boss 108 on the lower end of a generally vertical plunger 110 telescoped in an upwardly extending pedestal 112 of the mount 53. At its upper end the plunger 110 has a head 114 adapted to be engaged by a thumb or finger of the player for depressing the plunger to pivot the bar 100 and move the link 94 upwardly thereby causing the arm 38 to move from its normal position, as shown in FIGURES 9 and 10, for example, to its extended punching position as shown in FIGURE 5. The plunger 110 is resiliently urged to a normal upper position, in which position the arm 38 is in its normal guard position, by means of a spiral compression spring 116 encircling the plunger 110 and seated within the pedestal 112 between an enlarged lower portion of the head 114 and a seat 117 within the pedestal. The spring 116, operating through the bar 100 and the link 94 causes the arm 38 to return from its punching position (FIGURE 5) to its normal guard position (FIGURES 9 and 10).

With particular reference to FIGURE 2, it will be seen that each mount 53 carries a pair of pedestals 112 and associated plungers 110, one plunger operating each of the arms 38 of the associated fighter 30 or 32. The pedestals 112 serve as handles to be gripped, one by each hand of the player, for moving the mount 53 from side to side and in and out with respect to the ring 20 to thereby move

the associated fighter about the ring. As may best be seen in FIGURE 10, the plate 52, which mounts the fighter, is of such size as to completely cover an opening 120 in the base 28, and is rigidly connected, as by suitable lugs 122 with the inner end of mount 53. The outer end of the mount 53 extends through a slot 124 in the adjacent side of the platform 22 of the boxing ring 20 and rests on the flange 53a. The slot 124 is wider than the adjacent portion of the mount 53 to permit movement of the mount from side to side. Thus, the associated fighter is always in face to face opposed relationship to the other fighter and may be moved a limited amount in the boxing ring 20, as indicated by the solid and dotted line positions of the left hand plate 52 in FIGURE 4, while maintaining such general face to face relationship with other fighter.

In order to indicate the winner of the fight, and to add an amusing feature to the fighters 30 and 32, their heads 50 are mounted for movement from a normal position as indicated by solid lines in FIGURES 2 and 10, to an elevated position as indicated by the dotted lines in these figures. As previously discussed, when either fighters head is properly hit by the other fighter, the head abruptly pops up to its elevated position. Herein each head 50 is rigidly mounted on a depending bar 130, as may best be seen in FIGURES 10-13. This bar is slidable through an opening 132 in a neck web 134 of the upper torso portion 46, and in normal position of the head 50, a forwardly extending lug 136 on the bar 130 engages under an edge of the web 134 (FIGURES 10 and 11) to hold the head in its normal position as shown by solid lines in FIGURE 10. When the associated head 50 is hit with sufficient force to move the head rearwardly of the upper torso portion 46, the lug 136 is released from engagement with the edge of the web 134 and a spiral tension spring 138 snaps the bar 130 upwardly so that the head 50 pops upwardly to the position indicated by dotted lines in FIGURE 10. The spring 138 is connected at its upper end to the web 134 and at its lower end to a horizontally extending member 140 which further serves as an abutment for engaging a guiding web 142 of the upper torso 46 to halt upward movement of the head.

The web 142 is below the web 134 and further serves as a portion of a sounding box 144 secured to the upper torso 46. This sounding box is part of a noisemaker means which provides a zinging sound as the head 50 pops up to its extended position. Herein the noisemaker means includes a resilient reed 146 firmly secured to a wall 148 of the sounding box and is integral with and extends upwardly from the web 142. An upper free end of the reed 146 is curved so that a convex face of the reed engages and may ride across the teeth of a serrated wheel 150. The serrated wheel 150 is integral with a horizontal shaft 152 journaled in opposite sides 153 of the sounding box and this shaft carries an integral flywheel 154 to maintain rotation of the serrated wheel 150 for an extended period of time. The serrated wheel 150 is drivingly meshed with a rack 154 on the forward face of the bar 130, so that as the tension spring 138 snaps the bar 130 upwardly and the rack out of driving engagement with the serrated wheel 150 the wheel is rotated in a counterclockwise direction to vibrate the reed 146 and provide the zinging sound.

To summarize the operation of the toy, each fighter 30 and 32 is operated by one of a pair of players. The players grasp the pedestals 112 of the associated actuating means and may thereby move the associated fighter from side to side or toward and away from the opposing fighter. In normal position, the fighter's arms 38 are in guard position, as shown in FIGURE 1, and upon depressing a plunger 110 the associated arm 38 of the fighter moves from the guard position outwardly to punch at the opposing fighter and attempt to hit the opposing fighter's head 50 so as to cause the head to pop up, to the accompaniment of the zinging sound, thereby indicating that the

successful puncher won the fight. The articulated arm movement whereby the forearm 44 moves relatively to the upper arm 42 provides an interesting and realistic punching feature and serves to maintain a child's interest in the toy. Upon one of the fighter's heads 50 popping up it is merely necessary to press downwardly on the head so that the lug 136 may again latch with the edged position of the web 134.

Various components of the toy may be made of any desired material, and preferably the boxing ring 20, including the ropes 26, the fighters 30 and 32 and the actuating means mount 53 are a suitable plastic material. Various of the gears and other parts of the actuating linkage may be made of a suitable plastic or metal as desired.

While this invention has been described with particular reference to certain structure, operation and materials in a particular environment, various changes may be apparent to one skilled in the art, and the invention is not to be limited to such structure, operation, materials or environment. Various of the features in the invention are set forth in the following claims.

We claim:

A manually operable boxing game including a boxing ring, a pair of fighters opposed to each other and movable about the ring, each fighter being mounted on a platform which is movable relative to the ring and having a pair of individually movable arms with the upper arm movable relative to the body of the figure and the forearm movable relative to the upper arm through first means including a shaft fixed to the upper arm and journaled in the body, a first gear concentric with such shaft and fixed to the body, a second gear fixed to the forearm and concentric with a pivotal connection between the upper arm and forearm and drivenly connected with the first gear, whereby upon rotation of said shaft said upper arm moves relative to

the body and said forearm moves relative to said upper arm, a head movably mounted on the body, second means urging said head to move upwardly away from the body, latch means normally retaining said head in a position adjacent the body and responsive to a blow on the head to release said head for upward movement away from the body by said second means, a noisemaker within the body, and means operatively interconnecting the head and noisemaker so that as the head moves upwardly from the body it actuates said noisemaker, and manually operable actuating means connected with each fighter for moving each of said platforms and the fighters about the ring and for actuating each of said arms thereof to move the arms relative to the body and to move the forearm relative to the upper arm, said arm actuating means each including a handle portion outside of said ring having a depressable button, and linkage connecting said depressable button with said shaft fixed to said upper arm.

References Cited by the Examiner

UNITED STATES PATENTS

1,745,434	2/1930	McIntosh	-----	46-142
2,269,095	1/1942	Davis	-----	46-142
2,614,365	10/1952	Musselwhite et al.	----	46-119
2,716,840	9/1955	Armstrong	-----	46-142
3,053,008	9/1962	Pelunis	-----	46-119
3,060,631	10/1962	Collischan	-----	46-118
3,064,389	11/1962	Lemelson	-----	46-192
3,106,800	10/1963	Fletcher	-----	46-142 X

FOREIGN PATENTS

456,967 3/1928 Germany.

RICHARD C. PINKHAM, Primary Examiner.