



(11) **EP 1 994 863 A2**

(12) **EUROPEAN PATENT APPLICATION**

(43) Date of publication:  
**26.11.2008 Bulletin 2008/48**

(51) Int Cl.:  
**A47H 5/14 (2006.01) E06B 9/262 (2006.01)**

(21) Application number: **07109146.6**

(22) Date of filing: **29.05.2007**

(84) Designated Contracting States:  
**AT BE BG CH CY CZ DE DK EE ES FI FR GB GR HU IE IS IT LI LT LU LV MC MT NL PL PT RO SE SI SK TR**  
Designated Extension States:  
**AL BA HR MK RS**

(72) Inventor: **Lin, Tzong Fu**  
**Taipei (TW)**

(74) Representative: **Kayser, Martin et al**  
**Bauer Vorberg Kayser**  
**Patentanwälte**  
**Lindenallee 43**  
**50968 Köln (DE)**

(30) Priority: **22.05.2007 US 751799**

(71) Applicant: **WholeSpace Industries, Inc.**  
**Taipei (TW)**

(54) **A window covering**

(57) A window covering is disclosed that has a first rail (1), a double spool (4) connected to the first rail (1), at least one motor (13) connected to the first rail (1), and window covering material (2) extending from the first rail (1). A plurality of primary lift cords (9) extends from the first spool portion (22) of the double spool (4) and is connected to the window covering material (2) such that rotation of the double spool (4) in a first direction extends

the window covering material (2) away from the first rail (1) and rotation of the double spool (4) in an opposite second direction retracts the window covering material (2) toward the first rail (1). One or more secondary cords (11) extend from the second spool portion (22) of the double spool (4) and are connected to the one or more motors (13).

**EP 1 994 863 A2**

**Description****FIELD OF INVENTION**

**[0001]** The present invention relates to cordless window coverings.

**BACKGROUND OF THE INVENTION**

**[0002]** Cordless blinds have been available for many years. These blinds have cords that run between the headrail and the bottom rail and are collected on spools or axles in the headrail or bottom rail. Spring motors or electric motors are provided to turn the spools or axles on which the cords are collected. Examples of cordless shades in which the cords are wound on spools connected to spring motors can be found in patents of Otto Kuhar and Ren Judkins. For example, Kuhar discloses a balanced cordless window covering in United States Patent Nos. 6,474,394; 6,234,236 and 6,079,471. Judkins discloses a cordless blind which utilizes a constant force spring motor and lock mechanism in United States Patent No. 6,644,372. Frequently each lift cord is wound on a separate spool. One difficulty that is encountered when lift cords are wound on multiple spools is that the cords must be wound and unwound evenly so that the bottom rail is always level.

**[0003]** For most shades more than one spring motor is used. Kuhar discloses a gear system that is used to connect the spring motors together. Because of the size and weight of the motors most cordless blinds place the motors in the headrail, although the motors have been placed in the center of the bottomrail. The location of the spring motors in the headrail is limited by other mechanisms such as a tilter that may be in the headrail. Consequently, there is a need for a lift mechanism for cordless blinds that enables the motors to be placed in any of a variety of locations as selected by the fabricator.

**[0004]** It is also known in the art to connect two or more lift cords together at one end and then attach that connection to a secondary cord at a connection point. Cheng et al. disclose a cordless blind that has a secondary cord that is tied to the primary lift cords and extends to a spring motor. See United States Patent Nos. 6,991,020 and 6,837,294 to Cheng et al. and U.S. Patent Publication No 2004/0154758 to Cheng et al. The spring motor balances and holds the window covering material after it is raised or lowered by a user.

**[0005]** The connection of primary and secondary cords requires a substantial length of cord between the connection point and rollers within the headrail to avoid the risk of entangling the connection point with the rollers. Thus, the blinds disclosed by Cheng et al. require the primary cords to extend a substantial length between a roller and the secondary cord to ensure that no portion of the secondary cord extends to a roller when the blind is lowered. Such a length requires very long headrails.

**[0006]** Further, the headrails for such blinds are often

configured to have numerous rollers positioned throughout the length of the headrail to engage the primary cords and ensure the primary cords have the required length between the secondary cord and rollers. The use of these extra rollers increases the cost of the window covering. The headrail that houses the extra rollers may also be required to be taller to accommodate the multiple cord paths and rollers. Many users prefer a narrow headrail that is less noticeable. However, a narrow headrail cannot be used with the mechanism disclosed by Cheng et al.

**[0007]** The use of multiple rollers in the cord path also creates more friction in the system as compared to a cord path with no rollers. The increased friction requires that a stronger spring motor or more powerful electric motor be used, which can increase the cost of the window covering.

**[0008]** There is a need for a window covering lift system for a cordless window covering that does not require multiple cord paths within the headrail to evenly lift or lower the window covering.

**SUMMARY OF THE INVENTION**

**[0009]** I provide a window covering that has window covering material extending from a first rail and also has a double spool connected to the first rail. A plurality of primary lift cords are connected to the first spool side of the double spool. The primary lift cords extend from the first spool side and are connected to the window covering material such that rotation of the double spool in a first direction extends the window covering material away from the first rail and rotation of the double spool in an opposite second direction retracts the window covering material toward the first rail. At least one secondary cord is connected to the second spool side of the double spool. The one or more secondary cords extend from the second spool side to one or more motors connected to the first rail.

**[0010]** The motors may be spring motors or electric motors. Preferably, each secondary cord is connected to a respective motor or plurality of motors. For example, in one embodiment a first spring motor and a second spring motor can be connected to respective secondary cords. The first secondary cord can extend from the second spool side of the double spool to the first spring motor and the second secondary cord can extend from the second spool side of the double spool to the second spring motor. The two spring motors could be spaced apart from or adjacent one another. In an alternative embodiment, one secondary cord may extend from the second spool side of the double spool to a be connected to a set of interconnected spring motors.

**[0011]** The window covering material can be slats on ladders, woven woods, woven grasses, cellular materials, pleated materials, fabrics, or films. In some embodiments, the window covering can have a second rail connected to the window covering material. The plurality of primary lift cords may extend from the first spool side to

the second rail.

**[0012]** Other details, objects, and advantages of the invention will become apparent as the following description of certain present preferred embodiments thereof proceeds.

### **BRIEF DESCRIPTION OF THE DRAWING**

**[0013]** In the accompanying drawing I have shown certain present preferred embodiments of my window covering in which:

Figure 1 is an exploded view of a present preferred embodiment of my window covering with an optional additional spring motor shown in dotted line.

### **DETAILED DESCRIPTION OF PRESENT PREFERRED EMBODIMENTS**

**[0014]** Referring to Figure 1, a first present preferred embodiment 10 has a headrail 1 that houses a plurality of rollers 3, a double spool 4, and a spring motor 13. Window covering material 2 extends from the headrail to a bottom rail 7. The headrail is preferably narrow and houses one or more spring motors 13 having spools 16. Cradles 23 are provided to carry rollers 3 in the headrail 1 and a cover 41 is provided over each spring motor.

**[0015]** Primary lift cords 9 (shown in dotted line) are connected to the first spool side 22 of the double spool. The primary lift cords extend from the first spool side 22, pass over rollers 3 and extend through the window covering material 2 to the bottom rail 7. When the double spool 4 rotates in a first direction, the primary lift cords 9 are unwound from the first spool side 22 of the double spool, which extends the window covering material 2 away from the headrail to lower the window covering. When the double spool rotates in an opposite second direction, the primary lift cords are wound about the spool, retracting the window covering toward the headrail to raise the window covering material.

**[0016]** A secondary cord 11 (shown in dot-dash line) is connected to the second spool side 24 of the double spool and extends from the second spool side 24 to the spring motor 13. The secondary cord is connected to spool 16 of the spring motor. Spool 16 is connected to the spring motor such that the spring motor biases spool 16 against rotation in the first direction.

**[0017]** When a user wishes to lower the window covering material 2 of the first present preferred embodiment 10, the user exerts a downward pulling force on the bottom rail 7 that must be greater than the biasing force of the spring motor 13. The applied force causes double spool 4 and spool 16 to rotate in a first direction, lowering the window covering material by extending the window covering material 2 and bottom rail 7 away from the headrail. When that force is removed, the biasing force provided by the spring motor 13 maintains the window covering material at the desired location by preventing the

spool 16 and double spool 4 from any further rotation in the first direction.

**[0018]** If a user desires to raise the blind, the user exerts a slightly upward force on the bottom rail. In some embodiments, the upward force need only be sufficient to support a small fraction of the weight of the window covering material. The upward force provided by a user permits the biasing force provided by the spring motor 13 to rotate spool 16 in a second direction that is opposite to the first direction, winding the secondary cord about spool 16. The motion of the secondary cord causes the double spool 4 to rotate in the second direction, which winds the primary cords about the first spool side 22 of the double spool. The window covering material 2 is retracted toward the headrail 1 as the primary cords are wound about the first spool side 22, raising the window covering material 2 and bottom rail 7.

**[0019]** Because the primary cords are wound on a single spool, i.e., one side of the double spool, they will be wound and unwound at the same rate. Consequently, the bottom rail 7 is always level when the window covering material 2 is lowered or raised.

**[0020]** It should be appreciated that headrails having various short or narrow configurations can be used because the double spool collects all the excess primary cords and secondary cord. Further, the use of the double spool eliminates the entanglement or "hang up" problems that can be caused when the secondary cord is directly connected to the primary cords.

**[0021]** For heavier shades, it may be necessary to have more than one spring motor. Two or more spring motors could be connected together to turn a single cord collection spool which receives the secondary cord. Alternatively, one can use a second secondary cord 11a that runs between collection spool 16a attached to spring motor 13a and the second spool side 24 of the double spool to provide additional biasing force against rotation of the double spool in the first direction. The additional spring motor 13a could be placed on an opposite end of the headrail as shown or on the same end of the headrail as spring motor 13. Indeed, the present design enables placement of the motor or motors anywhere within the headrail.

**[0022]** In alternative embodiments of the present invention, the double spool, rollers, and spring motors can be housed within the bottom rail. In such embodiments, the lift cords extend from the first spool side of the double spool to the window covering material and are connected to the headrail.

**[0023]** In Figure 1, the window covering material is illustrated as a roman shade. One could use cellular material, pleated material, fabrics, films, or slats hung on ladders for the window cover material. If the window covering is slats on ladders, or a venetian blind, one may provide a tilter in the blind.

**[0024]** Similarly, the window covering is illustrated as having spring motors 13, 13a in Figure 1. It should be understood that electric motors can be used in combina-

tion with or in replacement of the spring motors. When electric motors are used, a remote control can be provided that is configured to actuate the electric motors to lower or raise the window covering

**[0025]** While I have shown and described certain present preferred embodiments of my window covering and have illustrated certain present preferred methods of making and using the same, it is to be distinctly understood that the invention is not limited thereto but may be otherwise variously embodied and practiced within the scope of the following claims.

### Claims

1. A window covering comprising:

a first rail;  
 a double spool having a first spool side and a second spool side connected to the first rail;  
 window covering material extending from the first rail;  
 at least one motor connected to the first rail;  
 a plurality of primary lift cords connected to the first spool side of the double spool, the plurality of primary lift cords extending from the first spool side of the double spool and connected to the window covering material such that rotation of the double spool in a first direction extends the window covering material away from the first rail and rotation of the double spool in an opposite second direction retracts the window covering material toward the first rail; and  
 at least one secondary cord connected to the second spool side of the double spool, the at least one secondary cord connected to the at least one motor.

2. The window covering of claim 1 further comprising a second rail connected to the window covering material.

3. The window covering of claim 2 wherein the plurality of primary lift cords extend from the first spool side of the double spool through the window covering material to the second rail.

4. The window covering of claim 1 wherein the window covering material is a material selected from the group consisting of slats on ladders, woven woods, woven grasses, cellular materials, pleated materials, fabrics and films.

5. The window covering of claim 1 further comprising a plurality of rollers connected to the first rail, each roller engaging a portion of at least one of the plurality of primary lift cords

6. The window covering of claim 1 wherein the at least one motor comprises a first spring motor and a second spring motor and the at least one secondary cord comprises a first secondary cord and a second secondary cord, the first secondary cord being connected to the first spring motor and the second secondary cord being connected to the second spring motor.

7. The window covering of claim 1 wherein the at least one motor is at least one motor selected from the group consisting of spring motors and electric motors.

8. The window covering of a claim 1 wherein the at least one motor is comprised of two spring motors.

9. The window covering of claim 8 wherein the spring motors are spaced apart from one another.

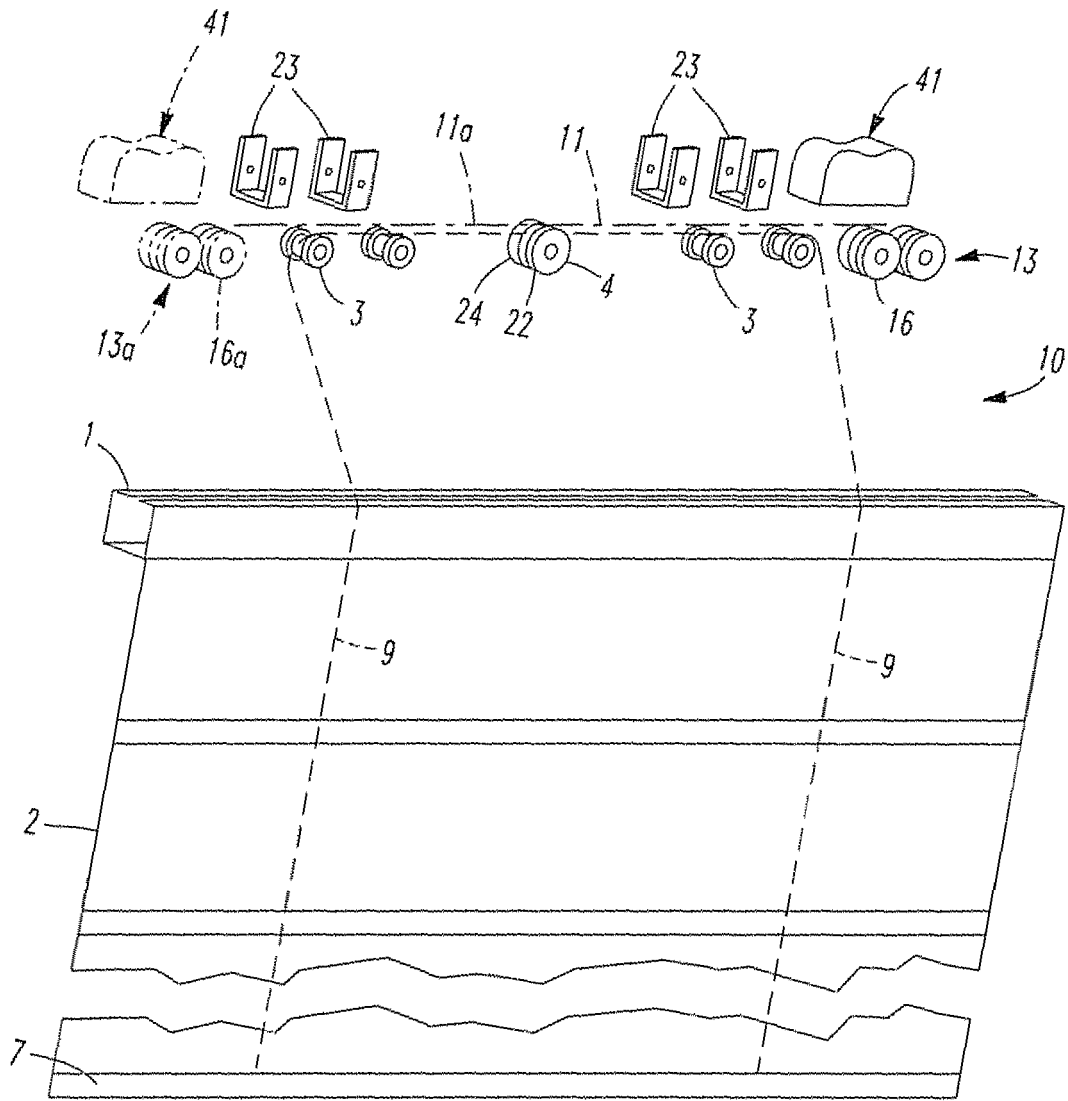

FIG. 1

**REFERENCES CITED IN THE DESCRIPTION**

*This list of references cited by the applicant is for the reader's convenience only. It does not form part of the European patent document. Even though great care has been taken in compiling the references, errors or omissions cannot be excluded and the EPO disclaims all liability in this regard.*

**Patent documents cited in the description**

- US 6474394 B [0002]
- US 6234236 B [0002]
- US 6079471 A [0002]
- US 6644372 B [0002]
- US 6991020 B [0004]
- US 6837294 B, Cheng [0004]
- US 20040154758 A, Cheng [0004]