



(11) **EP 4 008 926 B1**

(12) **EUROPEAN PATENT SPECIFICATION**

(45) Date of publication and mention of the grant of the patent:
06.11.2024 Bulletin 2024/45

(21) Application number: **20211871.7**

(22) Date of filing: **04.12.2020**

(51) International Patent Classification (IPC):
F16F 1/26^(2006.01)

(52) Cooperative Patent Classification (CPC):
F16F 1/26; F16F 2224/0208

(54) **A LEAF SPRING BRACKET**
BLATTFEDERHALTERUNG
SUPPORT DE RESSORT À LAMES

(84) Designated Contracting States:
AL AT BE BG CH CY CZ DE DK EE ES FI FR GB GR HR HU IE IS IT LI LT LU LV MC MK MT NL NO PL PT RO RS SE SI SK SM TR

(43) Date of publication of application:
08.06.2022 Bulletin 2022/23

(73) Proprietor: **VOLVO TRUCK CORPORATION**
405 08 Göteborg (SE)

(72) Inventors:
• **RAMASAMY, Venkatachalam**
Bangalore, Karnataka 560048 (IN)

• **SANDRASEKARAN, Ramachandran**
Bengaluru, Karnataka 560093 (IN)

(74) Representative: **Lavoix**
2, place d'Estienne d'Orves
75441 Paris Cedex 09 (FR)

(56) References cited:
WO-A1-2018/211299 JP-A- S61 169 308
KR-B1- 101 426 699 US-A- 5 850 069
US-B1- 6 206 407

EP 4 008 926 B1

Note: Within nine months of the publication of the mention of the grant of the European patent in the European Patent Bulletin, any person may give notice to the European Patent Office of opposition to that patent, in accordance with the Implementing Regulations. Notice of opposition shall not be deemed to have been filed until the opposition fee has been paid. (Art. 99(1) European Patent Convention).

Description

TECHNICAL FIELD

[0001] The invention relates to a first leaf spring bracket, a suspension system of a vehicle axle, a vehicle comprising said suspension system and a method for the manufacture of the first leaf spring bracket.

[0002] The invention can be applied in heavy-duty vehicles, such as trucks, buses and construction equipment, but is not restricted to these vehicles.

BACKGROUND

[0003] A conventional suspension for a vehicle includes a leaf spring, made of one leaf or several superimposed leaves, which is arranged longitudinally adjacent and under a frame girder of the vehicle.

[0004] There are provided a front leaf spring bracket and a rear leaf spring bracket, both secured to the vehicle frame. The leaf spring front-end portion is engaged in the front leaf spring bracket, generally with no degree of freedom along the longitudinal direction, while the leaf spring rear end portion is engaged in the rear leaf spring bracket to be able to slide longitudinally relative to the first leaf spring bracket. Furthermore, the leaf spring comprises an intermediate portion engaged in an intermediate attachment device for attaching the vehicle axle to the vehicle frame.

[0005] Generally, the suspension is only made of Austempered Ductile Iron (ADI). Indeed, due to the sliding principle, high wear resistance material like ADI is needed for the suspension. However, the production cost of the suspension made of ADI is high and the suspension is heavy.

[0006] US 6,206,407 B1 discloses a first leaf spring bracket comprising an insert. This document does not disclose spheroidal graphite cast iron as material for a bracket, or a insert having arms comprising two perpendicular arms which contain holes and being arranged in a configuration where a bottom surface of the bracket pad would be configured to receive a top surface of the insert.

[0007] There is a need to minimize the production cost of the suspension and to reduce the weight of the bracket suspension without compromising its mechanical properties.

SUMMARY

[0008] An object of the invention is to provide a cost saving suspension system, in particular a leaf spring bracket, having a reduced weight while maintaining the mechanical properties.

[0009] To that end, according to a first aspect, the invention concerns a first leaf spring bracket according to claim 1.

[0010] ADI is only used for the manufacture of a spe-

cific region where the first leaf spring bracket receives a rear end portion of a leaf spring and SGCI is used for the rest of the first leaf spring bracket. Thus, the first leaf spring bracket according to the present invention has a reduced weight and is cost saving. Additionally, the mechanical properties of the first leaf spring bracket are maintained.

[0011] The invention is particularly favourable for a suspension system which comprises said first leaf spring bracket.

[0012] In one embodiment, the insert pad has a concave or convex shape. In a preferred embodiment, the insert pad has a convex shape.

[0013] In one embodiment, the bracket pad has a concave or convex shape. In a preferred embodiment, the bracket pad has a convex shape.

[0014] In one embodiment, the insert pad comprises a protrusion located on its top surface and the bottom surface of bracket comprises a groove able to receive said protrusion. This embodiment allows for an improved fixation of the insert pad and the bottom surface of bracket.

[0015] In one embodiment, the bracket further comprises two lateral arms extending longitudinally. In one embodiment, the bracket further comprises a central arm that overhangs the bracket pad and the insert pad.

[0016] In one embodiment, the at least one element chosen from among: the central arm of the bracket and the two the two lateral arms of the bracket, comprises at least one hole. In this embodiment, the holes are configured to receive for example a screw in order to set the first leaf spring bracket to a girder frame.

[0017] According to the invention, the perpendicular arms of the insert and the two perpendicular arms of the bracket comprise at least one hole. In this embodiment, holes are configured to receive a fastener.

[0018] According to a second aspect, the invention concerns a suspension system of a vehicle axle comprising:

- a leaf spring having a longitudinal axis and a transverse axis and comprising a rear end portion, preferably loop-shaped,
- a first leaf spring bracket according to the present invention, the first leaf spring bracket being configured to be secured to a vehicle frame and which receives a rear end portion of a leaf spring so as to allow said leaf spring rear end portion to slide longitudinally relative to the first leaf spring bracket, and
- a fastener extending substantially transversally, the bracket and insert pads being located above the fastener.

[0019] The suspension system of a vehicle axle according to the present invention has a reduced weight and is cost saving thanks to the first leaf spring bracket.

[0020] In one embodiment, the leaf spring comprises a rear end portion substantially flat and has a top surface in contact with the first leaf spring bracket and insert pads

and a bottom surface.

[0021] In one embodiment, the suspension system further comprises a second leaf spring bracket configured to be secured to the vehicle frame and an intermediate attachment device, the leaf spring comprising a front end portion, preferably loop-shaped, which is engaged in said second leaf spring bracket and an intermediate portion engaged in said intermediate attachment device for attaching the vehicle axle to the vehicle frame.

[0022] According to a third aspect, the invention concerns a vehicle comprising a frame, an axle and a suspension system according to the present invention.

[0023] According to a third aspect, the invention concerns a method for the manufacture of the first leaf spring bracket according to claim 12.

[0024] In one embodiment, in step B), the manufacture of the insert onto the bracket is performed by compound casting. Compound casting simplifies joining processes by directly casting the melted insert onto a solid bracket. A continuously metallurgic transition is very important for industrial applications, such as joint structures of suspension systems. By using the compound casting, the first leaf spring bracket is a hybrid construction from the combination of the two materials. ADI and SGI form a bonding via form closure and force closure.

[0025] In one embodiment, in step B), the manufacture of the insert onto the bracket is performed by thermal spraying. In this embodiment, the melted insert is sprayed onto the bracket. For example, the thermal spraying include: plasma spraying, detonation spraying, wire arc spraying, Flame spraying, High velocity oxy-fuel coating spraying (HVOF), High velocity air fuel (HVOF), Warm spraying, Cold spraying and Spray and Fuse.

[0026] Further advantages and advantageous features of the invention are disclosed in the following description and in the dependent claims.

BRIEF DESCRIPTION OF THE DRAWINGS

[0027] With reference to the appended drawings, below follows a more detailed description of embodiments of the invention cited as examples.

[0028] In the drawings:

Fig. 1 is a perspective view of a first leaf spring bracket according to the present invention,

Fig. 2 is a perspective view of a bracket included in a first leaf spring bracket according to the present invention,

Fig. 3 is a perspective view of an insert included in a first leaf spring bracket according to the present invention and

Fig. 4 is a suspension system comprising a first leaf spring bracket according to the present invention.

DETAILED DESCRIPTION OF EXAMPLE EMBODIMENTS OF THE INVENTION

[0029] Figure 1 illustrates a first leaf spring bracket 1 that can comprise an insert 2 and a bracket 3. The longitudinal direction X is defined as the longitudinal direction of first leaf spring bracket 1. The transverse direction Y is the direction of the first leaf spring bracket 1, and Z is the vertical direction.

[0030] The bracket 3 can comprise a bracket pad 31 extending transversally and two perpendicular arms 32, said bracket 3 comprising a bottom surface 33 and a top surface 34. The bracket 3 is made of spheroidal graphite cast iron. The bracket 3 can further comprise two lateral arms 35 extending longitudinally and a central arm 36 that overhangs the bracket pad 33 and the insert pad 21 (Figure 2).

[0031] The insert 2 can comprise an insert pad 21 extending transversally and two perpendicular arms 22, said insert 2 comprising a bottom surface 23 and a top surface 24 and being made of austempered ductile iron (Figure 3).

[0032] As shown in Figure 1, the bottom surface 33 of the bracket pad 31 can be configured to receive the top surface 24 of the insert 2.

[0033] In the illustrated Examples, the insert pad 21 has a convex shape and the bracket pad 31 has a convex shape. The insert pad 21 comprises a protrusion located on its top surface and the bottom surface of bracket 33 comprises a groove (not illustrated) able to receive said protrusion 25.

[0034] For example, the central arm 36 of the bracket 3 can comprise three holes and the two lateral arms 35 of the bracket 3 comprise one hole. In this case, the holes are configured to receive a screw to be set on a girder frame.

[0035] For example, the two perpendicular arms 32 of the bracket 3 can each comprise one hole and the two perpendicular arms 22 of the insert 2 can each comprise one hole. In this case, these holes are configured to receive a fastener 43.

[0036] The first leaf spring bracket 1 can be manufactured by following steps:

- A. The provision of a bracket 3, said bracket 3 being made of spheroidal graphite cast iron and
- B. The manufacture of the insert 2 onto the bracket 3, said insert 2 being made of austempered ductile iron.

[0037] For example, in step B), the manufacture of the insert 2 onto the bracket 3 is performed by compound casting allowing a hybrid first leaf spring bracket wherein the insert 2 and the bracket 3 are strongly bonded by form closure and force closure.

[0038] Figure 4 illustrates an example of a suspension system 4 of a vehicle axle comprising a leaf spring 41, preferably loop-shaped, having a longitudinal axis X and

a transverse axis Y. The leaf spring 41 can comprise a rear end portion 42. The leaf spring 41, which can typically be made of metal such as steel.

[0039] The first leaf spring bracket 1 is configured to be secured to a vehicle frame and receives the rear end portion 42 of a leaf spring 41 so as to allow said leaf spring rear end portion 42 to slide longitudinally relative to the first leaf spring bracket 1. The leaf spring 41 can comprise a rear end portion 42 substantially flat and has a top surface 42a in contact with the bracket 31 and insert pads 21 and a bottom surface 42b. The leaf spring 41 has a substantially horizontal top surface 42a and a substantially horizontal bottom surface 42b (when the vehicle is on a horizontal ground). The width of the leaf spring 41 can be substantially identical over the whole length.

[0040] The suspension system 4 can comprise a fastener 43 extending substantially transversally, the bracket 31 and insert pads 21 being located above the fastener 43.

[0041] The suspension system 4 further can comprise a second leaf spring bracket 44 configured to be secured to the vehicle frame and an intermediate attachment device 45. The leaf spring 41 comprises a front end portion 46, preferably loop-shaped, which is engaged in said second leaf spring bracket 44 and an intermediate portion 47 engaged in said intermediate attachment device 45 for attaching the vehicle axle to the vehicle frame.

[0042] The leaf spring rear end portion 41 can move longitudinally relative to the first leaf spring bracket 1, in the forward direction and preferably also in the rearward direction, with the fastener 43 and the leaf spring top surface 42a sliding against the bracket 31 and insert 21 pads.

[0043] A vehicle (not illustrated) can comprise a frame (not illustrated) including for example two girders (not illustrated), an axle (not illustrated) mounted on the frame and a suspension system 4.

[0044] The invention ensures a cost saving suspension system, in particular a leaf spring bracket, having a reduced weight while maintaining the mechanical properties.

[0045] It is to be understood that the present invention is not limited to the embodiments described above and illustrated in the drawings; rather, the skilled person will recognize that many changes and modifications may be made within the scope of the appended claims.

Claims

1. A first leaf spring bracket (1) having a longitudinal axis (X) and a transverse axis (Y) which is configured to be secured to a vehicle frame and which receives a rear end portion (42) of a leaf spring (1) so as to allow said leaf spring rear end portion (42) to slide longitudinally relative to the first leaf spring bracket (1), wherein said first leaf spring bracket (1) comprises:

- an insert (2) comprising an insert pad (21) extending transversally, said insert comprising a bottom surface (23) and a top surface (24) and being made of austempered ductile iron,

- a bracket (3) comprising a bracket pad (31) extending transversally and two perpendicular arms (32) which contain at least one hole configured to receive a fastener (43), said bracket (3) comprising a bottom surface (33) and a top surface (34), the bottom surface (33) of the bracket pad (31) being configured to receive the top surface (24) of the insert (2), the first leaf spring bracket (1) being configured such that:

- the bracket (3) is made of spheroidal graphite cast iron,

- the insert (2) comprises two perpendicular arms (22) which contain at least one hole configured to receive the fastener (43).

2. The first leaf spring bracket (1) according to claim 1, wherein the insert pad (21) has a concave or convex shape.

3. The first leaf spring bracket (1) according to claim 1 or 2, wherein the bracket pad (31) has a concave or convex shape.

4. The first leaf spring bracket (1) according to anyone of claims 1 to 3, wherein the insert pad (21) comprises a protrusion (25) located on its top surface (24) and the bottom surface (33) of bracket (3) comprises a groove able to receive said protrusion (25).

5. The first leaf spring bracket (1) according to anyone of claims 1 to 4, wherein the bracket (3) further comprises two lateral arms (35) extending longitudinally.

6. The first leaf spring bracket (1) according to anyone of claims 1 to 5, wherein the bracket (3) further comprises a central arm (36) that overhangs the bracket pad (31) and the insert pad (21).

7. The first leaf spring bracket (1) according to anyone of claims 1 to 6, wherein at least one element chosen from among: the central arm (36) of the bracket (3), the two lateral arms (35) of the bracket (3), comprises at least one hole.

8. A suspension system (4) of a vehicle axle **characterized in that** said suspension system (4) comprises:

- a leaf spring (41) having a longitudinal axis (X) and a transverse axis (Y) and comprising a rear end portion (42), preferably loop-shaped,

- a first leaf spring bracket (1) according to anyone of claims 1 to 7, the first leaf spring bracket (1) being configured to be secured to a vehicle

- frame and which receives a rear end portion (42) of a leaf spring (41) so as to allow said leaf spring rear end portion (42) to slide longitudinally relative to the first leaf spring bracket (1), and
- a fastener (43) extending substantially transversally, the bracket (31) and insert pads (21) being located above the fastener (43).
9. The suspension system (4) according to claim 8, wherein the leaf spring (41) comprises a rear end portion (42) substantially flat and has a top surface (42a) in contact with the bracket (31) and insert pads (21) and a bottom surface (42b).
10. The suspension system (4) according to claim 8 or 9, wherein the suspension system (4) further comprises a second leaf spring bracket (44) configured to be secured to the vehicle frame and an intermediate attachment device (45), the leaf spring (41) comprising a front end portion (46), preferably loop-shaped, which is engaged in said second leaf spring bracket (44) and an intermediate portion (47) engaged in said intermediate attachment device (45) for attaching the vehicle axle to the vehicle frame.
11. A vehicle comprising a frame and an axle, **characterized in that** it further comprises a suspension system (4) according to anyone of claims 8 to 10.
12. A method for the manufacture of the first leaf spring bracket (1) according to anyone of claims 1 to 7, said method comprising the following steps:
- A. The provision of the bracket (3) and
 - B. The manufacture of the insert (2) onto the bracket (3).
13. The method according to claim 12, wherein in step B), the manufacture of the insert (2) onto the bracket (3) is performed by compound casting.
14. The method according to claim 12, wherein in step B), the manufacture of the insert (2) onto the bracket (3) is performed by thermal spraying.
- Patentansprüche**
1. Erste Blattfederhalterung (1), die eine Längsachse (X) und eine Querachse (Y) aufweist, die so konfiguriert ist, um an einem Fahrzeugrahmen befestigt zu werden und die einen hinteren Endabschnitt (42) einer Blattfeder (1) aufnimmt, um zu ermöglichen, dass der hintere Endabschnitt (42) der Blattfeder in Längsrichtung in Bezug auf die erste Blattfederhalterung (1) gleitet, wobei die erste Blattfederhalterung (1) Folgendes umfasst:
- einen Einsatz (2), umfassend ein Einsatzkissen (21), das sich quer erstreckt, der Einsatz umfassend eine untere Fläche (23) und eine obere Fläche (24) und aus ausgetempertem, duktilem Eisen gefertigt ist,
 - eine Halterung (3), umfassend ein sich quer erstreckendes Halterungskissen (31) und zwei senkrechte Arme (32), die mindestens ein Loch enthalten, das konfiguriert ist, um ein Befestigungselement (43) aufzunehmen, die Halterung (3) umfassend eine untere Fläche (33) und eine obere Fläche (34), wobei die untere Fläche (33) des Halterungspolsters (31) konfiguriert ist, um die obere Fläche (24) des Einsatzes (2) aufzunehmen, wobei die erste Blattfederhalterung (1) konfiguriert ist, sodass:
 - die Halterung (3) aus Kugelgraphitgusseisen gefertigt ist,
 - der Einsatz (2) zwei senkrechte Arme (22) umfasst, die mindestens ein Loch enthalten, das konfiguriert ist, um das Befestigungselement (43) aufzunehmen.
2. Erste Blattfederkonsole (1) nach Anspruch 1, wobei das Einsatzkissen (21) eine konkave oder konvexe Form aufweist.
3. Erste Blattfederkonsole (1) nach Anspruch 1 oder 2, wobei das Halterungskissen (31) eine konkave oder konvexe Form aufweist.
4. Erste Blattfederhalterung (1) nach einem der Ansprüche 1 bis 3, wobei das Einsatzkissen (21) einen Vorsprung (25) aufweist, der sich auf seiner Oberseite (24) befindet, und die Unterseite (33) der Halterung (3) eine Nut aufweist, die in der Lage ist, den Vorsprung (25) aufzunehmen.
5. Erste Blattfederkonsole (1) nach einem der Ansprüche 1 bis 4, wobei die Halterung (3) ferner zwei sich in Längsrichtung erstreckende seitliche Arme (35) umfasst.
6. Erste Blattfederkonsole (1) nach einem der Ansprüche 1 bis 5, wobei die Halterung (3) ferner einen mittleren Arm (36) umfasst, der über das Halterungskissen (31) und das Einsatzkissen (21) übersteht.
7. Erste Blattfederkonsole (1) nach einem der Ansprüche 1 bis 6, wobei mindestens ein Element, ausgewählt aus: dem mittleren Arm (36) der Halterung (3), den zwei seitlichen Armen (35) der Halterung (3), mindestens ein Loch umfasst.
8. Aufhängungssystem (4) einer Fahrzeugachse, **dadurch gekennzeichnet, dass** das Aufhängungssystem (4) Folgendes umfasst:

- eine Blattfeder (41), die eine Längsachse (X) und eine Querachse (Y) aufweist und umfassend einen hinteren, vorzugsweise schleifenförmigen Endabschnitt (42),
 - eine erste Blattfederhalterung (1) nach einem der Ansprüche 1 bis 7, wobei die erste Blattfederhalterung (1) konfiguriert ist, um an einem Fahrzeugrahmen befestigt zu werden und einen hinteren Endabschnitt (42) einer Blattfeder (41) aufzunehmen, um zu ermöglichen, dass der hintere Endabschnitt (42) der Blattfeder in Längsrichtung in Bezug auf die erste Blattfederhalterung (1) gleitet, und
 - ein Befestigungselement (43), das sich im Wesentlichen quer erstreckt, wobei sich die Halterung (31) und die Einsatzkissen (21) oberhalb des Befestigungselements (43) befinden.
9. Aufhängungssystem (4) nach Anspruch 8, wobei die Blattfeder (41) einen hinteren Endabschnitt (42) umfasst, der im Wesentlichen flach ist und eine obere Fläche (42a) in Kontakt mit der Halterung (31) und den Einsatzkissen (21) sowie eine untere Fläche (42b) aufweist.
10. Aufhängungssystem (4) nach Anspruch 8 oder 9, wobei das Aufhängungssystem (4) ferner eine zweite Blattfederhalterung (44), die konfiguriert ist, um an dem Fahrzeugrahmen befestigt zu werden, und eine Zwischenbefestigungsvorrichtung (45) umfasst, wobei die Blattfeder (41) einen vorderen, vorzugsweise schleifenförmigen Endabschnitt (46), der in die zweite Blattfederhalterung (44) eingreift, und einen Zwischenabschnitt (47) umfasst, der in die Zwischenbefestigungsvorrichtung (45) eingreift, um die Fahrzeugachse an dem Fahrzeugrahmen zu befestigen.
11. Fahrzeug, umfassend einen Rahmen und eine Achse, **dadurch gekennzeichnet, dass** es ferner ein Aufhängungssystem (4) nach einem der Ansprüche 8 bis 10 umfasst.
12. Verfahren zur Herstellung der ersten Blattfederhalterung (1) nach einem der Ansprüche 1 bis 7, das Verfahren umfassend die folgenden Schritte:
- A. Bereitstellen der Halterung (3) und
 - B. Herstellen des Einsatzes (2) auf der Halterung (3).
13. Verfahren nach Anspruch 12, wobei in Schritt B) die Herstellung des Einsatzes (2) auf der Halterung (3) durch Verbundguss erfolgt.
14. Verfahren nach Anspruch 12, wobei in Schritt B) die Herstellung des Einsatzes (2) auf der Halterung (3) durch thermisches Spritzen erfolgt.

Revendications

1. Premier support de ressort à lames (1) ayant un axe longitudinal (X) et un axe transversal (Y) qui est configuré pour être fixé au châssis d'un véhicule et qui reçoit une partie d'extrémité arrière (42) d'un ressort à lames (1) de manière à permettre à ladite partie d'extrémité arrière (42) de ressort à lames de coulisser longitudinalement par rapport au premier support de ressort à lames (1), dans lequel ledit premier support de ressort à lames (1) comprend :
 - un insert (2) comprenant un tampon d'insertion (21) s'étendant transversalement, ledit insert comprenant une surface inférieure (23) et une surface supérieure (24) et étant fabriqué en fonte ductile austénitique et bainitique,
 - un support (3) comprenant un tampon de support (31) s'étendant transversalement et deux bras perpendiculaires (32) qui contiennent au moins un trou configuré pour recevoir une fixation (43), ledit support (3) comprenant une surface inférieure (33) et une surface supérieure (34), la surface inférieure (33) du tampon de support (31) étant configurée pour recevoir la surface supérieure (24) de l'insert (2), le premier support de ressort à lames (1) étant configuré de sorte que :
 - le support (3) est constitué de fonte à graphite sphéroïdal,
 - l'insert (2) comprend deux bras perpendiculaires (22) qui contiennent au moins un trou configuré pour recevoir la fixation (43).
2. Premier support de ressort à lames (1) selon la revendication 1, dans lequel le tampon d'insertion (21) a une forme concave ou convexe.
3. Premier support de ressort à lames (1) selon la revendication 1 ou 2, dans lequel le tampon de support (31) a une forme concave ou convexe.
4. Premier support de ressort à lames (1) selon l'une quelconque des revendications 1 à 3, dans lequel le tampon d'insertion (21) comprend une saillie (25) située sur sa surface supérieure (24) et la surface inférieure (33) du support (3) comprend une rainure capable de recevoir ladite saillie (25).
5. Premier support de ressort à lames (1) selon l'une quelconque des revendications 1 à 4, dans lequel le support (3) comprend en outre deux bras latéraux (35) s'étendant longitudinalement.
6. Premier support de ressort à lames (1) selon l'une quelconque des revendications 1 à 5, dans lequel le

- support (3) comprend en outre un bras central (36) qui surplombe le tampon de support (31) et le tampon d'insertion (21).
7. Premier support de ressort à lames (1) selon l'une quelconque des revendications 1 à 6, dans lequel au moins un élément choisi parmi : le bras central (36) du support (3), les deux bras latéraux (35) du support (3), comporte au moins un trou. 5
8. Système de suspension (4) d'un essieu de véhicule **caractérisé en ce que** ledit système de suspension (4) comprend :
- un ressort à lames (41) ayant un axe longitudinal (X) et un axe transversal (Y) et comprenant une partie d'extrémité arrière (42), de préférence en forme de boucle, 15
 - un premier support de ressort à lames (1) selon l'une quelconque des revendications 1 à 7, le premier support de ressort à lames (1) étant configuré pour être fixé au châssis d'un véhicule et recevant une partie d'extrémité arrière (42) d'un ressort à lames (41) de manière à permettre à ladite partie d'extrémité arrière (42) de ressort à lames de coulisser longitudinalement par rapport au premier support de ressort à lames (1), et 20
 - une fixation (43) s'étendant sensiblement transversalement, les tampons de support (31) et d'insertion (21) étant situés au-dessus de la fixation (43). 25 30
9. Système de suspension (4) selon la revendication 8, dans lequel le ressort à lames (41) comprend une partie d'extrémité arrière (42) sensiblement plate et présente une surface supérieure (42a) en contact avec les tampons de support (31) et d'insertion (21) et une surface inférieure (42b). 35
10. Système de suspension (4) selon la revendication 8 ou 9, dans lequel le système de suspension (4) comprend en outre un second support de ressort à lames (44) configuré pour être fixé au châssis du véhicule et un dispositif de fixation intermédiaire (45), le ressort à lames (41) comprenant une partie d'extrémité avant (46), de préférence en forme de boucle, qui est en prise avec ledit second support de ressort à lames (44) et une partie intermédiaire (47) en prise avec ledit dispositif de fixation intermédiaire (45) pour fixer l'essieu du véhicule au châssis du véhicule. 40 45 50
11. Véhicule comprenant un châssis et un essieu, **caractérisé en ce qu'il** comprend en outre un système de suspension (4) selon l'une quelconque des revendications 8 à 10. 55
12. Procédé de fabrication du support de ressort à lames
- (1) selon l'une quelconque des revendications 1 à 7, ledit procédé comprenant les étapes suivantes :
- A. La fourniture du support (3) et
 - B. La fabrication de l'insert (2) sur le support (3).
13. Procédé selon la revendication 12, dans lequel, à l'étape B), la fabrication de l'insert (2) sur le support (3) est réalisée par moulage composite. 10
14. Procédé selon la revendication 12, dans lequel, à l'étape B), la fabrication de l'insert (2) sur le support (3) est réalisée par projection thermique. 15

Fig. 1

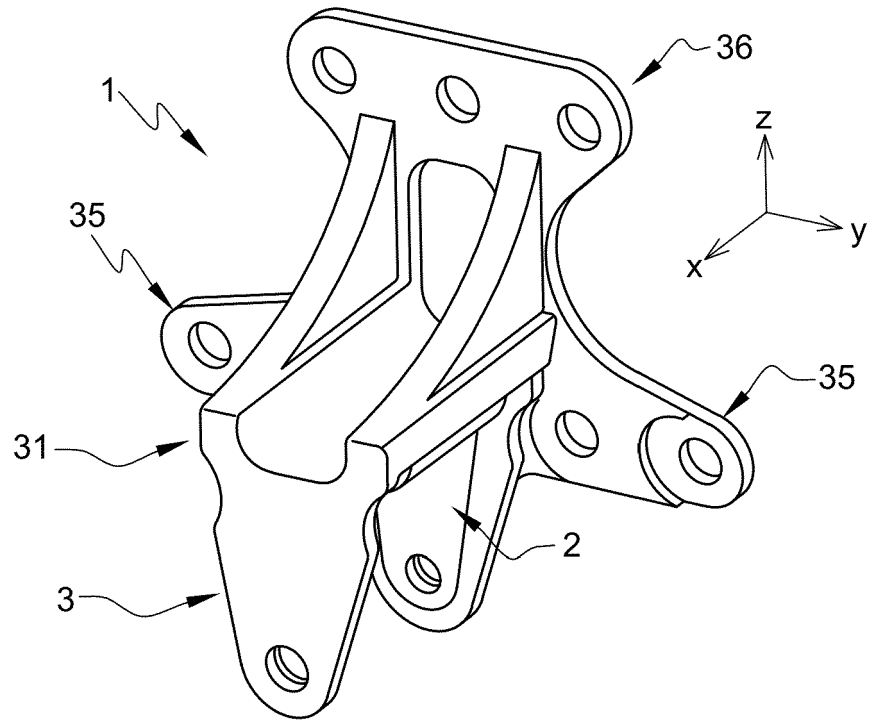

Fig. 2

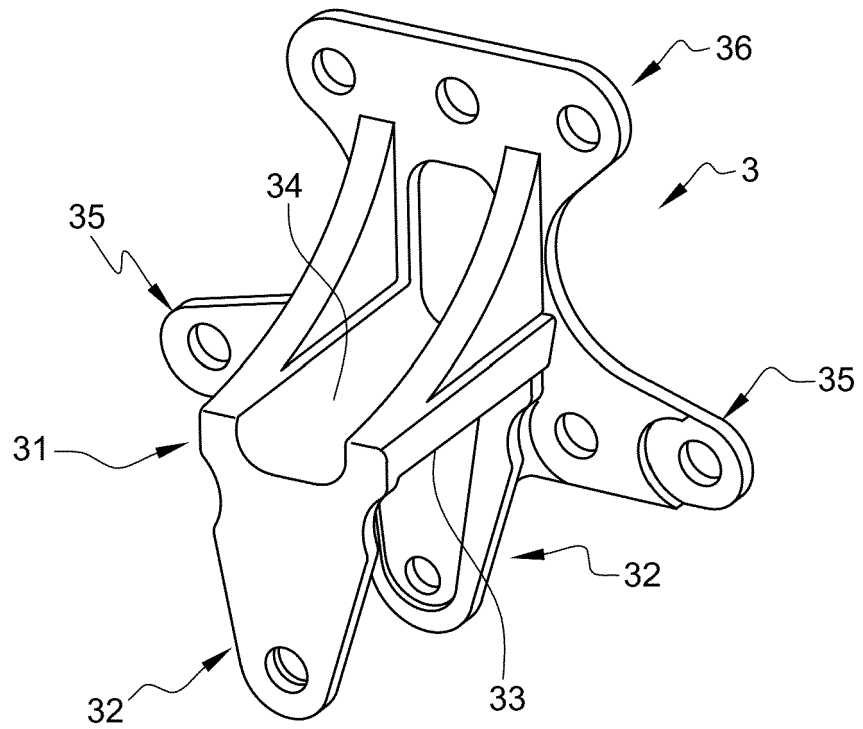

Fig. 3

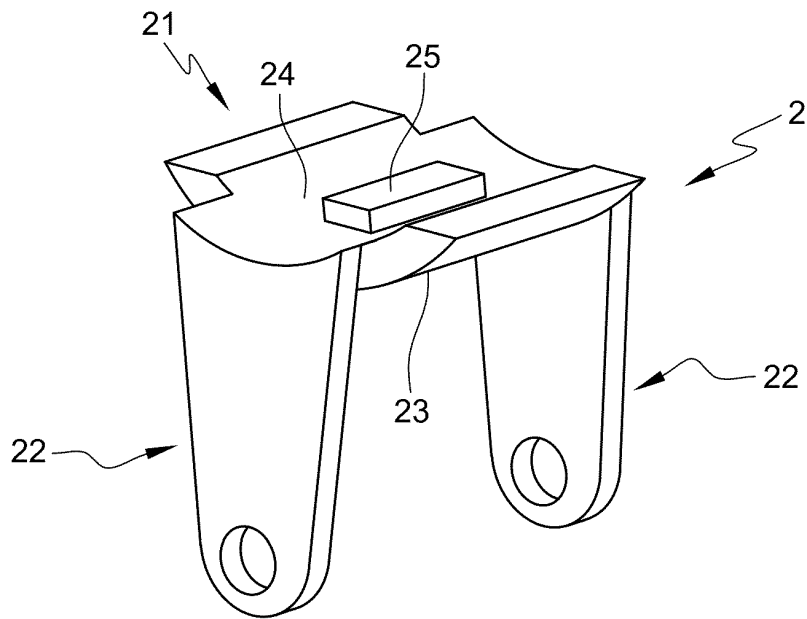
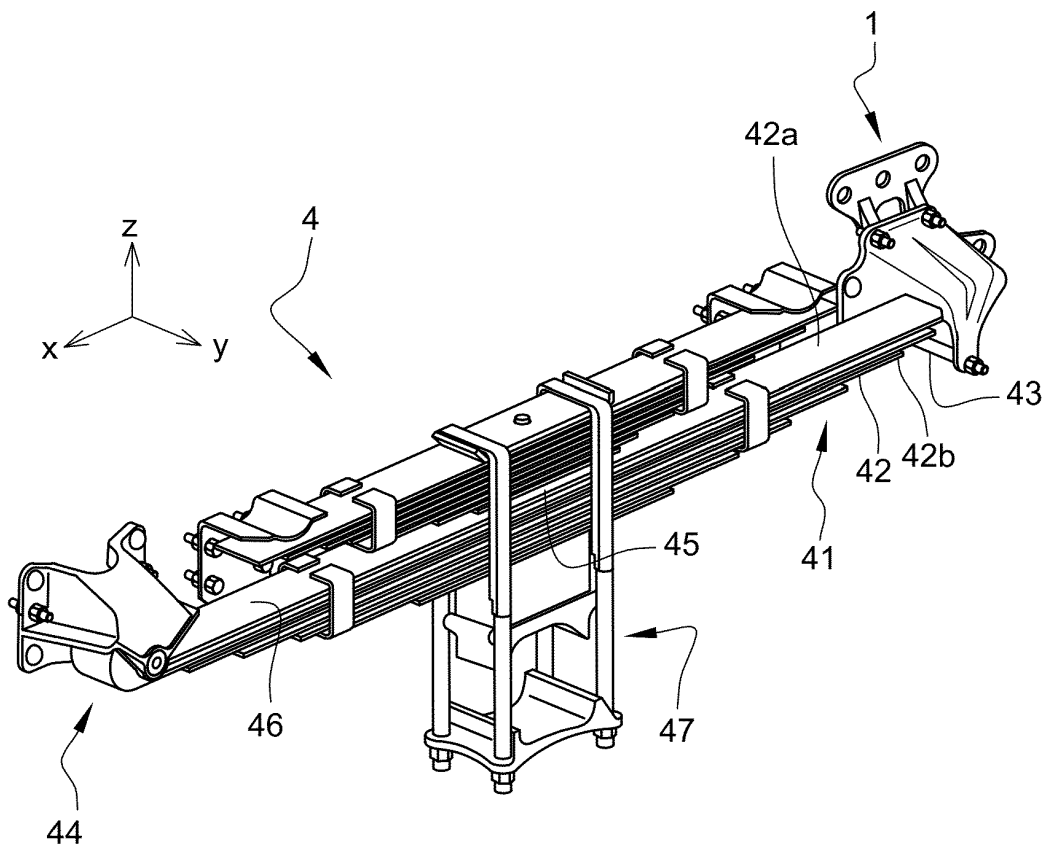

Fig. 4



REFERENCES CITED IN THE DESCRIPTION

This list of references cited by the applicant is for the reader's convenience only. It does not form part of the European patent document. Even though great care has been taken in compiling the references, errors or omissions cannot be excluded and the EPO disclaims all liability in this regard.

Patent documents cited in the description

- US 6206407 B1 [0006]