

(No Model.)

J. T. WRIGHT.
ROLLS FOR FORMING LINK BLANKS.

No. 308,452.

Patented Nov. 25, 1884.

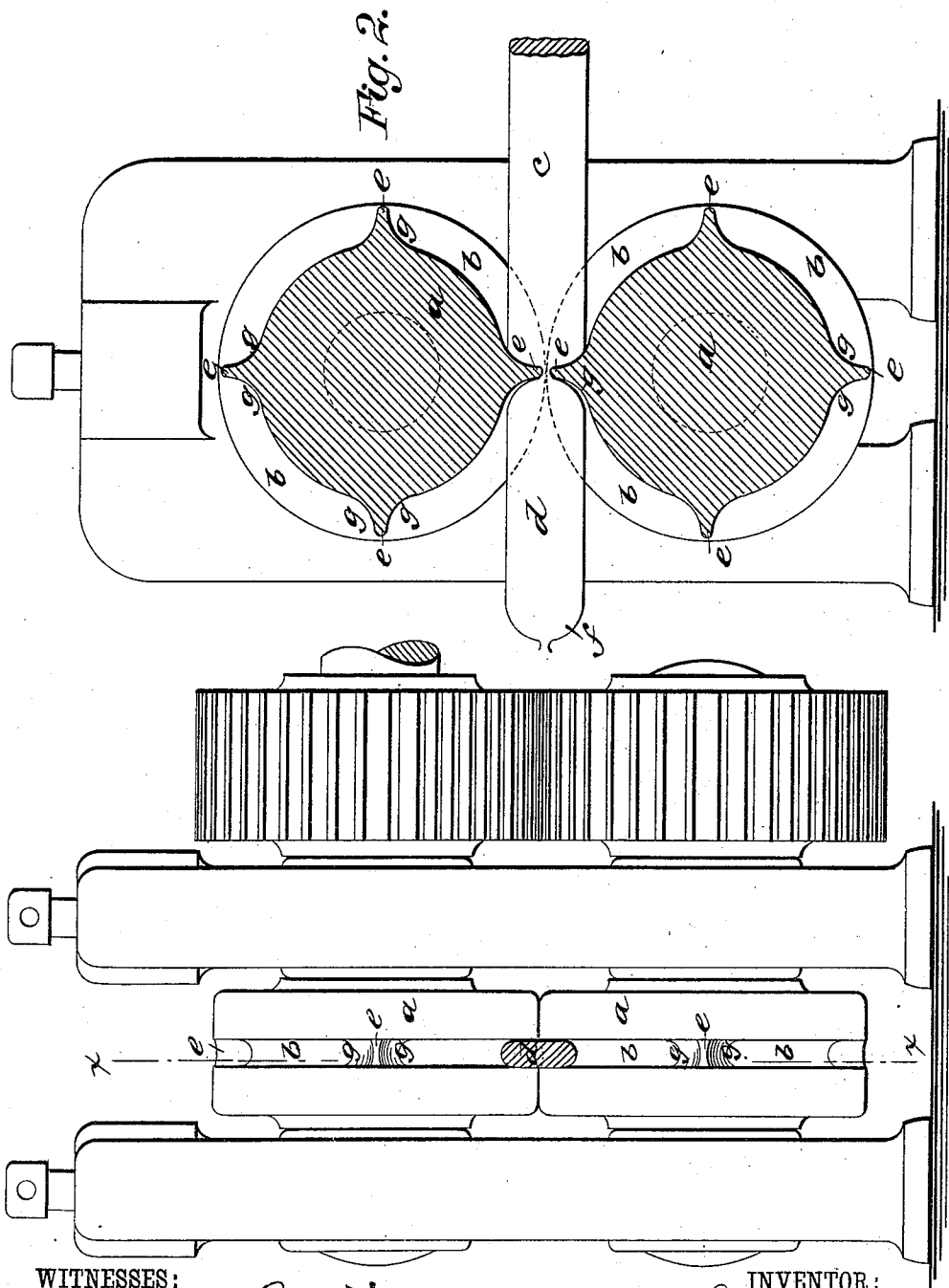

WITNESSES:

Motzger
W. Sedgwick

Fig. 1.

INVENTOR:

J. T. Wright
BY *Munn & Co*
ATTORNEYS.

UNITED STATES PATENT OFFICE.

JESSE THOMPSON WRIGHT, OF NEW ALBANY, INDIANA.

ROLL FOR FORMING LINK-BLANKS.

SPECIFICATION forming part of Letters Patent No. 308,452, dated November 25, 1884.

Application filed April 8, 1884. (No model.)

To all whom it may concern:

Be it known that I, JESSE T. WRIGHT, of New Albany, Floyd county, Indiana, have invented a new and useful Improvement in Forming Weldless Car-Coupling Links, of which the following is a full, clear, and exact description.

My improvement in forming weldless car-coupling links consists of forming the curved ends of blanks to be subsequently punched for making the pin-slot by making the last pass of the bar out of which the blanks are to be made when rolling said bar to prepare for the blanks in deep narrow grooves of the rolls, adapted for passing the bar edgewise, and having dies at distances apart corresponding to the length of the blanks to be made, and having the required form to shape the ends of the blanks by the act of separating the blanks from the bar, all as hereinafter fully described.

Reference is to be had to the accompanying drawings, forming part of this specification, in which similar letters of reference indicate corresponding parts in both figures.

Figure 1 is a front elevation of a pair of rolls contrived for shaping the exterior form of the link-blanks according to my invention; and Fig. 2 is a sectional elevation on the line $x x$, Fig. 1.

I provide a pair of rolls, a , such as are used for rolling metal, each having a groove, b , forming a pass adapted for finishing the bar c , out of which the blanks d are to be made edgewise, and I arrange dies e in the groove of each roll to form the curves of the ends f of the blanks, and at the same time and by the same operation cut off the blank from the bar, said dies being arranged transversely to the

grooves at suitable intervals apart corresponding to the length of the link-blanks, and having a substantial point or edge adapted to be forced into the hot metal, with concave sides g , corresponding to the desired curve f of the ends of the blanks. In this case I have represented these dies as being formed integral with the material of the rolls, but will in practice make them separately, and fit them in recesses of the rolls, suitably adapted for the purpose, with any improved means of securing them. It will be seen that this method of producing the blanks from the bar is very simple, and is calculated to accomplish the work rapidly without waste of material, and so as to condense the metal at the ends and increase its strength where it is subject to the severest stress in service. After thus making the blanks I propose to punch out the metal to make the pin-slots, and will utilize the metal so punched out for the coupling-pins.

Having thus described my invention, I claim as new and desire to secure by Letters Patent—

Rolls for making car-coupling-link blanks having a groove, b , for rolling the bar c edgewise in the finishing-pass to prepare said bar for the link-blanks, and also having dies e , with concave sides g , located at intervals along said grooves corresponding to the length of the link-blanks d , and adapted to cut said blanks from the bar, and at the same time form the curves f of the ends thereof, substantially as described.

JESSE THOMPSON WRIGHT. [L. S.]

Witnesses:

FRANK HOFFER, Jr.,
JAMES G. HARRISON.