



- (51) International Patent Classification:
E21B 47/09 (2012.01) G06K 19/077 (2006.01)
E21B 47/12 (2012.01)
- (21) International Application Number: PCT/US2014/072503
- (22) International Filing Date: 29 December 2014 (29.12.2014)
- (25) Filing Language: English
- (26) Publication Language: English
- (30) Priority Data: 14/145,307 31 December 2013 (31.12.2013) US
- (63) Related by continuation (CON) or continuation-in-part (CIP) to earlier application: US 14145307 (CON)
Filed on 31 December 2013 (31.12.2013)
- (71) Applicant: HALLIBURTON ENERGY SERVICES, INC. [US/US]; 10200 Bellaire Blvd, Houston, Texas 77072 (US).
- (72) Inventors: ROBERSON, Mark W.; 110 Lamlash Ln, Cary, North Carolina 27511 (US). GOODWIN, Scott; 20056 Long, Chapel Hill, North Carolina 27517 (US). RODDY, Craig W.; 2600 S. 2nd Street, Duncan, Oklahoma 73536 (US). RAVI, Krishna M.; P.O. Box 5622, Kingwood, Texas 77325 (US).
- (74) Agents: SCHEER, Bradley W. et al.; Schwegman, Lundberg & Woessner, P.A., P.O. Box 2938, Minneapolis, Minnesota 55402 (US).
- (81) Designated States (unless otherwise indicated, for every kind of national protection available): AE, AG, AL, AM, AO, AT, AU, AZ, BA, BB, BG, BH, BN, BR, BW, BY, BZ, CA, CH, CL, CN, CO, CR, CU, CZ, DE, DK, DM, DO, DZ, EC, EE, EG, ES, FI, GB, GD, GE, GH, GM, GT, HN, HR, HU, ID, IL, IN, IR, IS, JP, KE, KG, KN, KP, KR, KZ, LA, LC, LK, LR, LS, LU, LY, MA, MD, ME, MG,

[Continued on next page]

(54) Title: ALGORITHM FOR ZONAL FAULT DETECTION IN A WELL ENVIRONMENT

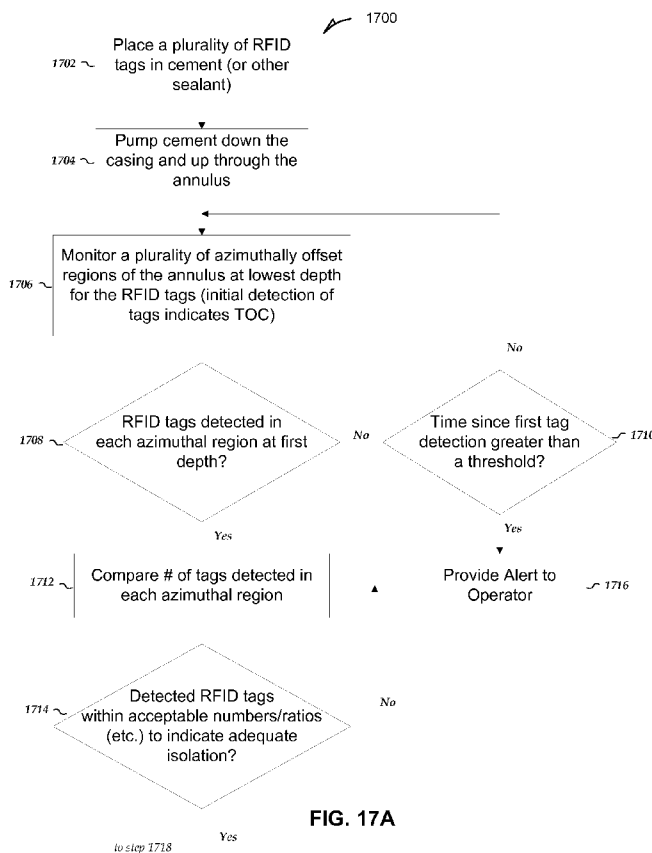

FIG. 17A

(57) Abstract: A hydrocarbon well (e.g., oil well) may be monitored during to determine whether a fault exists during an operation such as injecting sealant (e.g., cement) into the borehole. RFID tags may be mixed in a wellbore fluid (e.g., drilling mud, cement, etc.), placed into a borehole, and then tracked within the borehole by communication assemblies with RFID sensors. Data may be obtained by interrogating RFID tags in one or more azimuthally oriented regions of an annulus surrounding a casing of the borehole. Fluid distribution in the annulus will be evaluated with respect to azimuthally offset regions of the annulus.



MK, MN, MW, MX, MY, MZ, NA, NG, NI, NO, NZ, OM, PA, PE, PG, PH, PL, PT, QA, RO, RS, RU, RW, SA, SC, SD, SE, SG, SK, SL, SM, ST, SV, SY, TH, TJ, TM, TN, TR, TT, TZ, UA, UG, US, UZ, VC, VN, ZA, ZM, ZW.

TJ, TM), European (AL, AT, BE, BG, CH, CY, CZ, DE, DK, EE, ES, FI, FR, GB, GR, HR, HU, IE, IS, IT, LT, LU, LV, MC, MK, MT, NL, NO, PL, PT, RO, RS, SE, SI, SK, SM, TR), OAPI (BF, BJ, CF, CG, CI, CM, GA, GN, GQ, GW, KM, ML, MR, NE, SN, TD, TG).

(84) Designated States (*unless otherwise indicated, for every kind of regional protection available*): ARIPO (BW, GH, GM, KE, LR, LS, MW, MZ, NA, RW, SD, SL, ST, SZ, TZ, UG, ZM, ZW), Eurasian (AM, AZ, BY, KG, KZ, RU,

Published:

— *with international search report (Art. 21(3))*

ALGORITHM FOR ZONAL FAULT DETECTION IN A WELL ENVIRONMENT**Cross-Reference to Related Applications**

[0001] This application claims priority to U.S. Patent Application Serial No.
5 14/145,307, filed on 31 December 2013; which application is hereby incorporated
by reference herein its entirety and for all purposes.

Background of the Invention

[0002] This disclosure relates to the field of drilling, completing, servicing, and
treating a subterranean well, such as a hydrocarbon recovery well. In particular, the present
10 disclosure relates to systems and methods for detecting and/or monitoring the position
and/or condition of wellbore compositions, for example wellbore sealants such as cement,
using RFID tags (in some cases including micro-electrical mechanical system (MEMS)-based
data sensors). In some instances, the present disclosure describes methods of monitoring
different azimuthally offset regions of an annulus that surrounds a casing in a wellbore.

15 [0003] Natural resources such as gas, oil, and water residing in a subterranean
formation or zone are usually recovered by drilling a wellbore into the subterranean
formation while circulating a drilling fluid in the wellbore. After terminating the circulation
of the drilling fluid, a string of pipe (e.g., casing) is run in the wellbore. The drilling fluid is
then usually circulated downward through the interior of the pipe and upward through the
20 annulus, which is located between the exterior of the pipe and the walls of the wellbore.
Next, primary cementing is typically performed whereby a cement slurry is placed in the
annulus and permitted to set into a hard mass (i.e., sheath) to thereby attach the string of
pipe to the walls of the wellbore and seal the annulus. Subsequent secondary cementing
operations may also be performed. One example of a secondary cementing operation is
25 squeeze cementing whereby a cement slurry is employed to plug and seal off undesirable
flow passages in the cement sheath and/or the casing. Non-cementitious sealants are also
utilized in preparing a wellbore. For example, polymer, resin, or latex-based sealants may
be desirable for placement behind casing.

[0004] To enhance the life of the well and minimize costs, sealant slurries are chosen
30 based on calculated stresses and characteristics of the formation to be serviced. Suitable
sealants are selected based on the conditions that are expected to be encountered during
the sealant service life. Once a sealant is chosen, it is desirable to monitor and/or evaluate

the health of the sealant so that timely maintenance can be performed and the service life maximized. The integrity of sealant can be adversely affected by conditions in the well. For example, cracks in cement may allow water influx while acid conditions may degrade cement. The initial strength and the service life of cement can be significantly affected by its
5 moisture content from the time that it is placed. Moisture and temperature are the primary drivers for the hydration of many cements and are critical factors in the most prevalent deteriorative processes, including damage due to freezing and thawing, alkali-aggregate reaction, sulfate attack and delayed Ettringite (hexacalcium aluminate trisulfate) formation. Thus, it is desirable to measure one or more sealant parameters (e.g., moisture content,
10 temperature, pH and ion concentration) in order to monitor sealant integrity.

[0005] Active, embeddable sensors can involve drawbacks that make them undesirable for use in a wellbore environment. For example, low-powered (e.g., nanowatt) electronic moisture sensors are available, but have inherent limitations when embedded within cement. The highly alkali environment can damage their electronics, and they are
15 sensitive to electromagnetic noise. Additionally, power must be provided from an internal battery to activate the sensor and transmit data, which increases sensor size and decreases useful life of the sensor. Accordingly, an ongoing need exists for improved methods of monitoring wellbore sealant condition from placement through the service lifetime of the sealant.

20 [0006] Likewise, in performing wellbore servicing operations, an ongoing need exists for improvements related to monitoring and/or detecting a condition and/or location of a wellbore, formation, wellbore servicing tool, wellbore servicing fluid, or combinations thereof. Additionally, the usefulness of such monitoring is greatly improved through measurements in azimuthally defined regions of the annulus. Such needs may be met by the
25 systems and methods for use of RFID tags, in some cases with MEMS sensors, down hole in accordance with the various embodiments described herein.

Brief Description of the Drawings

[0007] FIG. 1 is a flow chart illustrating a method in accordance with some
30 embodiments.

[0008] FIG. 2 is a schematic of a typical onshore oil or gas drilling rig and wellbore in accordance with some embodiments.

- [0009] FIG. 3 is a flow chart illustrating a method for determining when a reverse cementing operation is complete and for subsequent optional activation of a downhole tool in accordance with some embodiments.
- 5 [0010] FIG. 4 is a flow chart illustrating a method for selecting between a group of sealant compositions in accordance with some embodiments.
- [0011] FIG. 5 is a schematic view of an embodiment of a wellbore parameter sensing system.
- [0012] FIG. 6 is a schematic view of another embodiment of a wellbore parameter sensing system.
- 10 [0013] FIG. 7 is a schematic view of still another embodiment of a wellbore parameter sensing system.
- [0014] FIG. 8 is a flow chart illustrating a method for servicing a wellbore in accordance with some embodiments.
- [0015] FIG. 9 is a flow chart illustrating another method for servicing a wellbore in
15 accordance with some embodiments.
- [0016] FIG. 10 is a schematic cross-sectional view of a casing in accordance with some embodiments.
- [0017] FIG. 11 is a schematic view of a further embodiment of a wellbore parameter sensing system.
- 20 [0018] FIG. 12 is a schematic view of yet another embodiment of a wellbore parameter sensing system.
- [0019] FIG. 13 is a flow chart illustrating a method for servicing a wellbore.
- [0020] FIG. 14 is a cross-sectional view of a communication assembly in accordance with some embodiments.
- 25 [0021] FIG. 15A is a side view of a communication assembly in accordance with a first embodiment.
- [0022] FIG. 15B is a side view of a communication assembly in accordance with a second embodiment.
- [0023] FIG. 15C is a side view of a communication assembly in accordance with a
30 third embodiment.
- [0024] FIG. 16 is a diagram of a cross section of a borehole with different azimuthally offset regions.

[0025] FIGs. 17A-B depict a flow chart illustrating an example method for determining faults in a fluid volume in a wellbore.

[0026] FIG. 18 depicts an embodiment of a portion of a wellbore parameter sensing system having acoustic sensors.

5

Detailed Description

[0027] Disclosed herein are methods for detecting and/or monitoring the position and/or condition of a wellbore, a formation, a wellbore service tool, and/or wellbore compositions, for example wellbore sealants such as cement, using MEMS-based data sensors. Still more particularly, the present disclosure describes methods of monitoring the integrity and performance of wellbore compositions over the life of the well using MEMS-based data sensors. Performance may be indicated by changes, for example, in various parameters, including, but not limited to, moisture content, temperature, pH, and various ion concentrations (e.g., sodium, chloride, and potassium ions) of the cement. In 10
embodiments, the methods comprise the use of embeddable data sensors capable of detecting parameters in a wellbore composition, for example a sealant such as cement. In 15
embodiments, the methods provide for evaluation of sealant during mixing, placement, and/or curing of the sealant within the wellbore. In another embodiment, the method is used for sealant evaluation from placement and curing throughout its useful service life, and 20
where applicable to a period of deterioration and repair. In embodiments, the methods of this disclosure may be used to prolong the service life of the sealant, lower costs, and enhance creation of improved methods of remediation. Additionally, methods are disclosed for determining the location of sealant within a wellbore, such as for determining the location of a cement slurry during primary cementing of a wellbore as discussed further 25
herein below. Additional embodiments and methods for employing MEMS-based data sensors in a wellbore are described herein.

[0028] The methods disclosed herein comprise the use of various wellbore compositions, including sealants and other wellbore servicing fluids. As used herein, "wellbore composition" includes any composition that may be prepared or otherwise 30
provided at the surface and placed down the wellbore, typically by pumping. As used herein, a "sealant" refers to a fluid used to secure components within a wellbore or to plug or seal a void space within the wellbore. Sealants, and in particular cement slurries and non-

cementitious compositions, are used as wellbore compositions in several embodiments described herein, and it is to be understood that the methods described herein are applicable for use with other wellbore compositions. As used herein, "servicing fluid" refers to a fluid used to drill, complete, work over, fracture, repair, treat, or in any way prepare or
5 service a wellbore for the recovery of materials residing in a subterranean formation penetrated by the wellbore. Examples of servicing fluids include, but are not limited to, cement slurries, non-cementitious sealants, drilling fluids or muds, spacer fluids, fracturing fluids or completion fluids, all of which are well known in the art. While fluid is generally understood to encompass material in a pumpable state, reference to a wellbore servicing
10 fluid that is settable or curable (e.g., a sealant such as cement) includes, unless otherwise noted, the fluid in a pumpable and/or set state, as would be understood in the context of a given wellbore servicing operation. Generally, wellbore servicing fluid and wellbore composition may be used interchangeably unless otherwise noted. The servicing fluid is for use in a wellbore that penetrates a subterranean formation. It is to be understood that
15 "subterranean formation" encompasses both areas below exposed earth and areas below earth covered by water such as ocean or fresh water. The wellbore may be a substantially vertical wellbore and/or may contain one or more lateral wellbores, for example as produced via directional drilling. As used herein, components are referred to as being "integrated" if they are formed on a common support structure placed in packaging of
20 relatively small size, or otherwise assembled in close proximity to one another.

[0029] Discussion of an embodiment of the method of the present disclosure will now be made with reference to the flowchart of FIG. 1, which includes methods of placing MEMS sensors in a wellbore and gathering data. At block 100, data sensors are selected based on the parameter(s) or other conditions to be determined or sensed within the
25 wellbore. At block 102, a quantity of data sensors is mixed with a wellbore composition, for example a sealant slurry. In embodiments, data sensors are added to a sealant by any methods known to those of skill in the art. For example, the sensors may be mixed with a dry material, mixed with one more liquid components (e.g., water or a non-aqueous fluid), or combinations thereof. The mixing may occur onsite, for example addition of the sensors
30 into a bulk mixer such as a cement slurry mixer. The sensors may be added directly to the mixer, may be added to one or more component streams and subsequently fed to the mixer, may be added downstream of the mixer, or combinations thereof. In embodiments,

data sensors are added after a blending unit and slurry pump, for example, through a lateral by-pass. The sensors may be metered in and mixed at the well site, or may be pre-mixed into the composition (or one or more components thereof) and subsequently transported to the well site. For example, the sensors may be dry mixed with dry cement and transported to the well site where a cement slurry is formed comprising the sensors. Alternatively or additionally, the sensors may be pre-mixed with one or more liquid components (e.g., mix water) and transported to the well site where a cement slurry is formed comprising the sensors. The properties of the wellbore composition or components thereof may be such that the sensors distributed or dispersed therein do not substantially settle during transport or placement.

[0030] The wellbore composition, e.g., sealant slurry, is then pumped downhole at block 104, whereby the sensors are positioned within the wellbore. For example, the sensors may extend along all or a portion of the length of the wellbore adjacent the casing. The sealant slurry may be placed downhole as part of a primary cementing, secondary cementing, or other sealant operation as described in more detail herein. At block 106, a data interrogation tool (also referred to as a data interrogator tool, data interrogator, interrogator, interrogation/communication tool or unit, or the like) is positioned in an operable location to gather data from the sensors, for example lowered or otherwise placed within the wellbore proximate the sensors. In various embodiments, one or more data interrogators may be placed downhole (e.g., in a wellbore) prior to, concurrent with, and/or subsequent to placement in the wellbore of a wellbore composition comprising MEMS sensors. At block 108, the data interrogation tool interrogates the data sensors (e.g., by sending out an RF signal) while the data interrogation tool traverses all or a portion of the wellbore containing the sensors. The data sensors are activated to record and/or transmit data at block 110 via the signal from the data interrogation tool. At block 112, the data interrogation tool communicates the data to one or more computer components (e.g., memory and/or microprocessor) that may be located within the tool, at the surface, or both. The data may be used locally or remotely from the tool to calculate the location of each data sensor and correlate the measured parameter(s) to such locations to evaluate sealant performance. Accordingly, the data interrogation tool comprises MEMS sensor interrogation functionality, communication functionality (e.g., transceiver functionality), or both.

[0031] Data gathering, as shown in blocks 106 to 112 of FIG. 1, may be carried out at the time of initial placement in the well of the wellbore composition comprising MEMS sensors, for example during drilling (e.g., drilling fluid comprising MEMS sensors) or during cementing (e.g., cement slurry comprising MEMS sensors) as described in more detail

5 below. Additionally or alternatively, data gathering may be carried out at one or more times subsequent to the initial placement in the well of the wellbore composition comprising MEMS sensors. For example, data gathering may be carried out at the time of initial placement in the well of the wellbore composition comprising MEMS sensors or shortly thereafter to provide a baseline data set. As the well is operated for recovery of natural

10 resources over a period of time, data gathering may be performed additional times, for example at regular maintenance intervals such as every 1 year, 5 years, or 10 years. The data recovered during subsequent monitoring intervals can be compared to the baseline data as well as any other data obtained from previous monitoring intervals, and such comparisons may indicate the overall condition of the wellbore. For example, changes in

15 one or more sensed parameters may indicate one or more problems in the wellbore. Alternatively, consistency or uniformity in sensed parameters may indicate no substantive problems in the wellbore. The data may comprise any combination of parameters sensed by the MEMS sensors as present in the wellbore, including but not limited to temperature, pressure, ion concentration, stress, strain, gas concentration, etc. In an embodiment, data

20 regarding performance of a sealant composition includes cement slurry properties such as density, rate of strength development, thickening time, fluid loss, and hydration properties; plasticity parameters; compressive strength; shrinkage and expansion characteristics; mechanical properties such as Young's Modulus and Poisson's ratio; tensile strength; resistance to ambient conditions downhole such as temperature and chemicals present; or

25 any combination thereof, and such data may be evaluated to determine long term performance of the sealant composition (e.g., detect an occurrence of radial cracks, shear failure, and/or de-bonding within the set sealant composition) in accordance with embodiments set forth in K. Ravi and H. Xenakis, "Cementing Process Optimized to Achieve Zonal Isolation," presented at PETROTECH-2007 Conference, New Delhi, India, which is

30 incorporated herein by reference in its entirety. In an embodiment, data (e.g., sealant parameters) from a plurality of monitoring intervals is plotted over a period of time, and a resultant graph is provided showing an operating or trend line for the sensed parameters.

Atypical changes in the graph as indicated for example by a sharp change in slope or a step change on the graph may provide an indication of one or more present problems or the potential for a future problem. Accordingly, remedial and/or preventive treatments or services may be applied to the wellbore to address present or potential problems.

5 [0032] In embodiments, the MEMS sensors are contained within a sealant composition placed substantially within the annular space between a casing and the wellbore wall. That is, substantially all of the MEMS sensors are located within or in close proximity to the annular space. In an embodiment, the wellbore servicing fluid comprising the MEMS sensors (and thus likewise the MEMS sensors) does not substantially penetrate, migrate, or travel into the formation from the wellbore. In an alternative embodiment, 10 substantially all of the MEMS sensors are located within, adjacent to, or in close proximity to the wellbore, for example less than or equal to about 1 foot, 3 feet, 5 feet, or 10 feet from the wellbore. Such adjacent or close proximity positioning of the MEMS sensors with respect to the wellbore is in contrast to placing MEMS sensors in a fluid that is pumped into 15 the formation in large volumes and substantially penetrates, migrates, or travels into or through the formation, for example as occurs with a fracturing fluid or a flooding fluid. Thus, in embodiments, the MEMS sensors are placed proximate or adjacent to the wellbore (in contrast to the formation at large), and provide information relevant to the wellbore itself and compositions (e.g., sealants) used therein (again in contrast to the formation or a 20 producing zone at large). In alternative embodiments, the MEMS sensors are distributed from the wellbore into the surrounding formation (e.g., additionally or alternatively non-proximate or non-adjacent to the wellbore), for example as a component of a fracturing fluid or a flooding fluid described in more detail herein.

[0033] In embodiments, the sealant is any wellbore sealant known in the art. 25 Examples of sealants include cementitious and non-cementitious sealants both of which are well known in the art. In embodiments, non-cementitious sealants comprise resin based systems, latex based systems, or combinations thereof. In embodiments, the sealant comprises a cement slurry with styrene-butadiene latex (e.g., as disclosed in U.S. Pat. No. 5,588,488 incorporated by reference herein in its entirety). Sealants may be utilized in 30 setting expandable casing, which is further described hereinbelow. In other embodiments, the sealant is a cement utilized for primary or secondary wellbore cementing operations, as discussed further hereinbelow.

[0034] In embodiments, the sealant is cementitious and comprises a hydraulic cement that sets and hardens by reaction with water. Examples of hydraulic cements include but are not limited to Portland cements (e.g., classes A, B, C, G, and H Portland cements), pozzolana cements, gypsum cements, phosphate cements, high alumina content cements, silica cements, high alkalinity cements, shale cements, acid/base cements, magnesia cements, fly ash cement, zeolite cement systems, cement kiln dust cement systems, slag cements, micro-fine cement, metakaolin, and combinations thereof. Examples of sealants are disclosed in U.S. Pat. Nos. 6,457,524; 7,077,203; and 7,174,962, each of which is incorporated herein by reference in its entirety. In an embodiment, the sealant comprises a sorel cement composition, which typically comprises magnesium oxide and a chloride or phosphate salt which together form for example magnesium oxychloride. Examples of magnesium oxychloride sealants are disclosed in U.S. Pat. Nos. 6,664,215 and 7,044,222, each of which is incorporated herein by reference in its entirety.

[0035] The wellbore composition (e.g., sealant) may include a sufficient amount of water to form a pumpable slurry. The water may be fresh water or salt water (e.g., an unsaturated aqueous salt solution or a saturated aqueous salt solution such as brine or seawater). In embodiments, the cement slurry may be a lightweight cement slurry containing foam (e.g., foamed cement) and/or hollow beads/microspheres. In an embodiment, the MEMS sensors are incorporated into or attached to all or a portion of the hollow microspheres. Thus, the MEMS sensors may be dispersed within the cement along with the microspheres. Examples of sealants containing microspheres are disclosed in U.S. Pat. Nos. 4,234,344; 6,457,524; and 7,174,962, each of which is incorporated herein by reference in its entirety. In an embodiment, the MEMS sensors are incorporated into a foamed cement such as those described in more detail in U.S. Pat. Nos. 6,063,738; 6,367,550; 6,547,871; and 7,174,962, each of which is incorporated by reference herein in its entirety.

[0036] In some embodiments, additives may be included in the cement composition for improving or changing the properties thereof. Examples of such additives include but are not limited to accelerators, set retarders, defoamers, fluid loss agents, weighting materials, dispersants, density-reducing agents, formation conditioning agents, lost circulation materials, thixotropic agents, suspension aids, or combinations thereof. Other mechanical property modifying additives, for example, fibers, polymers, resins, latexes, and the like can

be added to further modify the mechanical properties. These additives may be included singularly or in combination. Methods for introducing these additives and their effective amounts are known to one of ordinary skill in the art.

[0037] In embodiments, the MEMS sensors are contained within a wellbore composition that forms a filtercake on the face of the formation when placed downhole. For example, various types of drilling fluids, also known as muds or drill-in fluids have been used in well drilling, such as water-based fluids, oil-based fluids (e.g., mineral oil, hydrocarbons, synthetic oils, esters, etc.), gaseous fluids, or a combination thereof. Drilling fluids typically contain suspended solids. Drilling fluids may form a thin, slick filter cake on the formation face that provides for successful drilling of the wellbore and helps prevent loss of fluid to the subterranean formation. In an embodiment, at least a portion of the MEMS remain associated with the filtercake (e.g., disposed therein) and may provide information as to a condition (e.g., thickness) and/or location of the filtercake. Additionally or in the alternative at least a portion of the MEMS remain associated with drilling fluid and may provide information as to a condition and/or location of the drilling fluid.

[0038] In embodiments, the MEMS sensors are contained within a wellbore composition that when placed downhole under suitable conditions induces fractures within the subterranean formation. Hydrocarbon-producing wells often are stimulated by hydraulic fracturing operations, wherein a fracturing fluid may be introduced into a portion of a subterranean formation penetrated by a wellbore at a hydraulic pressure sufficient to create, enhance, and/or extend at least one fracture therein. Stimulating or treating the wellbore in such ways increases hydrocarbon production from the well. In some embodiments, the MEMS sensors may be contained within a wellbore composition that when placed downhole enters and/or resides within one or more fractures within the subterranean formation. In such embodiments, the MEMS sensors provide information as to the location and/or condition of the fluid and/or fracture during and/or after treatment. In an embodiment, at least a portion of the MEMS remain associated with a fracturing fluid and may provide information as to the condition and/or location of the fluid. Fracturing fluids often contain proppants that are deposited within the formation upon placement of the fracturing fluid therein, and in an embodiment a fracturing fluid contains one or more proppants and one or more MEMS. In an embodiment, at least a portion of the MEMS remain associated with the proppants deposited within the formation (e.g., a proppant bed)

and may provide information as to the condition (e.g., thickness, density, settling, stratification, integrity, etc.) and/or location of the proppants. Additionally or in the alternative at least a portion of the MEMS remain associated with a fracture (e.g., adhere to and/or retained by a surface of a fracture) and may provide information as to the condition
5 (e.g., length, volume, etc.) and/or location of the fracture. For example, the MEMS sensors may provide information useful for ascertaining the fracture complexity.

[0039] In embodiments, the MEMS sensors are contained in a wellbore composition (e.g., gravel pack fluid) which is employed in a gravel packing treatment, and the MEMS may provide information as to the condition and/or location of the wellbore composition during
10 and/or after the gravel packing treatment. Gravel packing treatments are used, inter alia, to reduce the migration of unconsolidated formation particulates into the wellbore. In gravel packing operations, particulates, referred to as gravel, are carried to a wellbore in a subterranean producing zone by a servicing fluid known as carrier fluid. That is, the particulates are suspended in a carrier fluid, which may be viscosified, and the carrier fluid is
15 pumped into a wellbore in which the gravel pack is to be placed. As the particulates are placed in the zone, the carrier fluid leaks off into the subterranean zone and/or is returned to the surface. The resultant gravel pack acts as a filter to separate formation solids from produced fluids while permitting the produced fluids to flow into and through the wellbore. When installing the gravel pack, the gravel is carried to the formation in the form of a slurry
20 by mixing the gravel with a viscosified carrier fluid. Such gravel packs may be used to stabilize a formation while causing minimal impairment to well productivity. The gravel, inter alia, acts to prevent the particulates from occluding the screen or migrating with the produced fluids, and the screen, inter alia, acts to prevent the gravel from entering the wellbore. In an embodiment, the wellbore servicing composition (e.g., gravel pack fluid)
25 comprises a carrier fluid, gravel and one or more MEMS. In an embodiment, at least a portion of the MEMS remain associated with the gravel deposited within the wellbore and/or formation (e.g., a gravel pack/bed) and may provide information as to the condition (e.g., thickness, density, settling, stratification, integrity, etc.) and/or location of the gravel pack/bed.

30 **[0040]** In various embodiments, the MEMS may provide information as to a location, flow path/profile, volume, density, temperature, pressure, or a combination thereof of a sealant composition, a drilling fluid, a fracturing fluid, a gravel pack fluid, or other wellbore

servicing fluid in real time such that the effectiveness of such service may be monitored and/or adjusted during performance of the service to improve the result of same.

Accordingly, the MEMS may aid in the initial performance of the wellbore service additionally or alternatively to providing a means for monitoring a wellbore condition or

5 performance of the service over a period of time (e.g., over a servicing interval and/or over the life of the well). For example, the one or more MEMS sensors may be used in monitoring a gas or a liquid produced from the subterranean formation. MEMS present in the wellbore and/or formation may be used to provide information as to the condition (e.g., temperature, pressure, flow rate, composition, etc.) and/or location of a gas or liquid

10 produced from the subterranean formation. In an embodiment, the MEMS provide information regarding the composition of a produced gas or liquid. For example, the MEMS may be used to monitor an amount of water produced in a hydrocarbon producing well (e.g., amount of water present in hydrocarbon gas or liquid), an amount of undesirable components or contaminants in a produced gas or liquid (e.g., sulfur, carbon dioxide, hydrogen sulfide, etc. present in hydrocarbon gas or liquid), or a combination thereof.

15 **[0041]** In embodiments, the data sensors added to the wellbore composition, e.g., sealant slurry, etc., are passive sensors that do not require continuous power from a battery or an external source in order to transmit real-time data. In embodiments, the data sensors are micro-electromechanical systems (MEMS) comprising one or more (and typically a plurality of) MEMS devices, referred to herein as MEMS sensors. MEMS devices are well known, e.g., a semiconductor device with mechanical features on the micrometer scale. MEMS embody the integration of mechanical elements, sensors, actuators, and electronics on a common substrate. In embodiments, the substrate comprises silicon. MEMS elements include mechanical elements which are movable by an input energy (electrical energy or other type of energy). Using MEMS, a sensor may be designed to emit a detectable signal based on a number of physical phenomena, including thermal, biological, optical, chemical, and magnetic effects or stimulation. MEMS devices are minute in size, have low power requirements, are relatively inexpensive and are rugged, and thus are well suited for use in wellbore servicing operations.

25 **[0042]** In embodiments, the MEMS sensors added to a wellbore servicing fluid may be active sensors, for example powered by an internal battery that is rechargeable or

otherwise powered and/or recharged by other downhole power sources such as heat capture/transfer and/or fluid flow, as described in more detail herein.

5 [0043] In embodiments, the data sensors comprise an active material connected to (e.g., mounted within or mounted on the surface of) an enclosure, the active material being liable to respond to a wellbore parameter, and the active material being operably connected to (e.g., in physical contact with, surrounding, or coating) a capacitive MEMS element. In various embodiments, the MEMS sensors sense one or more parameters within the wellbore. In an embodiment, the parameter is temperature. Alternatively, the parameter is pH. Alternatively, the parameter is moisture content. Still alternatively, the parameter may be ion concentration (e.g., chloride, sodium, and/or potassium ions). The MEMS sensors may also sense well cement characteristic data such as stress, strain, or combinations thereof. In embodiments, the MEMS sensors of the present disclosure may comprise active materials that respond to two or more measurands. In such a way, two or more parameters may be monitored.

15 [0044] In addition or in the alternative, a MEMS sensor incorporated within one or more of the wellbore compositions disclosed herein may provide information that allows a condition (e.g., thickness, density, volume, settling, stratification, etc.) and/or location of the composition within the subterranean formation to be detected.

[0045] Suitable active materials, such as dielectric materials, that respond in a predictable and stable manner to changes in parameters over a long period may be identified according to methods well known in the art, for example see, e.g., Ong, Zeng and Grimes. "A Wireless, Passive Carbon Nanotube-based Gas Sensor," IEEE Sensors Journal, 2, 2, (2002) 82-88; Ong, Grimes, Robbins and Singl, "Design and application of a wireless, passive, resonant-circuit environmental monitoring sensor," Sensors and Actuators A, 93 25 (2001) 33-43, each of which is incorporated by reference herein in its entirety. MEMS sensors suitable for the methods of the present disclosure that respond to various wellbore parameters are disclosed in U.S. Pat. No. 7,038,470 B1 that is incorporated herein by reference in its entirety.

[0046] In embodiments, the MEMS sensors are coupled with radio frequency identification devices (RFIDs) and can thus detect and transmit parameters and/or well cement characteristic data for monitoring the cement during its service life. RFIDs combine a microchip with an antenna (the RFID chip and the antenna are collectively referred to as

the "transponder" or the "tag"). The antenna provides the RFID chip with power when exposed to a narrow band, high frequency electromagnetic field from a transceiver. A dipole antenna or a coil, depending on the operating frequency, connected to the RFID chip, powers the transponder when current is induced in the antenna by an RF signal from the transceiver's antenna. Such a device can return a unique identification "ID" number by modulating and re-radiating the radio frequency (RF) wave. Passive RF tags are gaining widespread use due to their low cost, indefinite life, simplicity, efficiency, ability to identify parts at a distance without contact (tether-free information transmission ability). These robust and tiny tags are attractive from an environmental standpoint as they require no battery. The MEMS sensor and RFID tag are preferably integrated into a single component (e.g., chip or substrate), or may alternatively be separate components operably coupled to each other. In an embodiment, an integrated, passive MEMS/RFID sensor contains a data sensing component, an optional memory, and an RFID antenna, whereby excitation energy is received and powers up the sensor, thereby sensing a present condition and/or accessing one or more stored sensed conditions from memory and transmitting same via the RFID antenna.

[0047] In embodiments, MEMS sensors having different RFID tags, i.e., antennas that respond to RF waves of different frequencies and power the RFID chip in response to exposure to RF waves of different frequencies, may be added to different wellbore compositions. Within the United States, commonly used operating bands for RFID systems center on one of the three government assigned frequencies: 125 kHz, 13.56 MHz or 2.45 GHz. A fourth frequency, 27.125 MHz, has also been assigned. When the 2.45 GHz carrier frequency is used, the range of an RFID chip can be many meters. While this is useful for remote sensing, there may be multiple transponders within the RF field. In order to prevent these devices from interacting and garbling the data, anti-collision schemes are used, as are known in the art. In embodiments, the data sensors are integrated with local tracking hardware to transmit their position as they flow within a wellbore composition such as a sealant slurry.

[0048] The data sensors may form a network using wireless links to neighboring data sensors and have location and positioning capability through, for example, local positioning algorithms as are known in the art. The sensors may organize themselves into a network by listening to one another, therefore allowing communication of signals from the farthest

sensors towards the sensors closest to the interrogator to allow uninterrupted transmission and capture of data. In such embodiments, the interrogator tool may not need to traverse the entire section of the wellbore containing MEMS sensors in order to read data gathered by such sensors. For example, the interrogator tool may only need to be lowered about half-
5 way along the vertical length of the wellbore containing MEMS sensors. Alternatively, the interrogator tool may be lowered vertically within the wellbore to a location adjacent to a horizontal arm of a well, whereby MEMS sensors located in the horizontal arm may be read without the need for the interrogator tool to traverse the horizontal arm. Alternatively, the interrogator tool may be used at or near the surface and read the data gathered by the
10 sensors distributed along all or a portion of the wellbore. For example, sensors located a distance away from the interrogator (e.g., at an opposite end of a length of casing or tubing) may communicate via a network formed by the sensors as described previously.

[0049] In embodiments, the MEMS sensors are ultra-small, e.g., 3 mm^2 , such that they are pumpable in a sealant slurry. In embodiments, the MEMS device is approximately
15 0.01 mm^2 to 1 mm^2 , alternatively 1 mm^2 to 3 mm^2 , alternatively 3 mm^2 to 5 mm^2 , or alternatively 5 mm^2 to 10 mm^2 . In embodiments, the data sensors are capable of providing data throughout the cement service life. In embodiments, the data sensors are capable of providing data for up to 100 years. In an embodiment, the wellbore composition comprises an amount of MEMS effective to measure one or more desired parameters. In various
20 embodiments, the wellbore composition comprises an effective amount of MEMS such that sensed readings may be obtained at intervals of about 1 foot, alternatively about 6 inches, or alternatively about 1 inch, along the portion of the wellbore containing the MEMS. In an embodiment, the MEMS sensors may be present in the wellbore composition in an amount of from about 0.001 to about 10 weight percent. Alternatively, the MEMS may be present in
25 the wellbore composition in an amount of from about 0.01 to about 5 weight percent. In embodiments, the sensors may have dimensions (e.g., diameters or other dimensions) that range from nanoscale, e.g., about 1 to 1000 nm (e.g., NEMS), to a micrometer range, e.g., about 1 to 1000 μm (e.g., MEMS), or alternatively any size from about 1 nm to about 1 mm. In embodiments, the MEMS sensors may be present in the wellbore composition in an
30 amount of from about 5 volume percent to about 30 volume percent.

[0050] In various embodiments, the size and/or amount of sensors present in a wellbore composition (e.g., the sensor loading or concentration) may be selected such that

the resultant wellbore servicing composition is readily pumpable without damaging the sensors and/or without having the sensors undesirably settle out (e.g., screen out) in the pumping equipment (e.g., pumps, conduits, tanks, etc.) and/or upon placement in the wellbore. Also, the concentration/loading of the sensors within the wellbore servicing fluid
5 may be selected to provide a sufficient average distance between sensors to allow for networking of the sensors (e.g., daisy-chaining) in embodiments using such networks, as described in more detail herein. For example, such distance may be a percentage of the average communication distance for a given sensor type. By way of example, a given sensor having a 2 inch communication range in a given wellbore composition should be loaded into
10 the wellbore composition in an amount that the average distance between sensors is less than 2 inches (e.g., less than 1.9, 1.8, 1.7, 1.6, 1.5, 1.4, 1.3, 1.2, 1.1, 1.0, etc. inches). The size of sensors and the amount may be selected so that they are stable, do not float or sink, in the well treating fluid. The size of the sensor could range from nano size to microns. In some embodiments, the sensors may be nanoelectromechanical systems (NEMS), MEMS, or
15 combinations thereof. Unless otherwise indicated herein, it should be understood that any suitable micro and/or nano sized sensors or combinations thereof may be employed. The embodiments disclosed herein should not otherwise be limited by the specific type of micro and/or nano sensor employed unless otherwise indicated or prescribed by the functional requirements thereof, and specifically NEMS may be used in addition to or in lieu of MEMS
20 sensors in the various embodiments disclosed herein.

[0051] In embodiments, the MEMS sensors comprise passive (remain unpowered when not being interrogated) sensors energized by energy radiated from a data interrogation tool. The data interrogation tool may comprise an energy transceiver sending energy (e.g., radio waves) to and receiving signals from the MEMS sensors and a processor
25 processing the received signals. The data interrogation tool may further comprise a memory component, a communications component, or both. The memory component may store raw and/or processed data received from the MEMS sensors, and the communications component may transmit raw data to the processor and/or transmit processed data to another receiver, for example located at the surface. The tool components (e.g., transceiver,
30 processor, memory component, and communications component) are coupled together and in signal communication with each other.

[0052] In an embodiment, one or more of the data interrogator components may be integrated into a tool or unit that is temporarily or permanently placed downhole (e.g., a downhole module), for example prior to, concurrent with, and/or subsequent to placement of the MEMS sensors in the wellbore. In an embodiment, a removable downhole module
5 comprises a transceiver and a memory component, and the downhole module is placed into the wellbore, reads data from the MEMS sensors, stores the data in the memory component, is removed from the wellbore, and the raw data is accessed. Alternatively, the removable downhole module may have a processor to process and store data in the memory component, which is subsequently accessed at the surface when the tool is
10 removed from the wellbore. Alternatively, the removable downhole module may have a communications component to transmit raw data to a processor and/or transmit processed data to another receiver, for example located at the surface. The communications component may communicate via wired or wireless communications. For example, the downhole component may communicate with a component or other node on the surface
15 via a network of MEMS sensors, or cable or other communications/telemetry device such as a radio frequency, electromagnetic telemetry device or an acoustic telemetry device. The removable downhole component may be intermittently positioned downhole via any suitable conveyance, for example wire-line, coiled tubing, straight tubing, gravity, pumping, etc., to monitor conditions at various times during the life of the well.

[0053] In embodiments, the data interrogation tool comprises a permanent or semi-permanent downhole component that remains downhole for extended periods of time. For example, a semi-permanent downhole module may be retrieved and data downloaded once every few months or years. Alternatively, a permanent downhole module may remain in the well throughout the service life of well. In an embodiment, a permanent or semi-permanent
25 downhole module comprises a transceiver and a memory component, and the downhole module is placed into the wellbore, reads data from the MEMS sensors, optionally stores the data in the memory component, and transmits the read and optionally stored data to the surface. Alternatively, the permanent or semi-permanent downhole module may have a processor to process and sensed data into processed data, which may be stored in memory
30 and/or transmit to the surface. The permanent or semi-permanent downhole module may have a communications component to transmit raw data to a processor and/or transmit processed data to another receiver, for example located at the surface. The communications

component may communicate via wired or wireless communications. For example, the downhole component may communicate with a component or other node on the surface via a network of MEMS sensors, or a cable or other communications/telemetry device such as a radio frequency, electromagnetic telemetry device or an acoustic telemetry device.

5 [0054] In embodiments, the data interrogation tool comprises an RF energy source incorporated into its internal circuitry and the data sensors are passively energized using an RF antenna, which picks up energy from the RF energy source. In an embodiment, the data interrogation tool is integrated with an RF transceiver. In embodiments, the MEMS sensors (e.g., MEMS/RFID sensors) are empowered and interrogated by the RF transceiver from a
10 distance, for example a distance of greater than 10 m, or alternatively from the surface or from an adjacent offset well. In an embodiment, the data interrogation tool traverses within a casing in the well and reads MEMS sensors located in a wellbore servicing fluid or composition, for example a sealant (e.g., cement) sheath surrounding the casing, located in the annular space between the casing and the wellbore wall. In embodiments, the
15 interrogator senses the MEMS sensors when in close proximity with the sensors, typically via traversing a removable downhole component along a length of the wellbore comprising the MEMS sensors. In an embodiment, close proximity comprises a radial distance from a point within the casing to a planar point within an annular space between the casing and the wellbore. In embodiments, close proximity comprises a distance of 0.1 m to 1 m.
20 Alternatively, close proximity comprises a distance of 1 m to 5 m. Alternatively, close proximity comprises a distance of from 5 m to 10 m. In embodiments, the transceiver interrogates the sensor with RF energy at 125 kHz and close proximity comprises 0.1 m to 5 m. Alternatively, the transceiver interrogates the sensor with RF energy at 13.5 MHz and close proximity comprises 0.05 m to 0.5 m. Alternatively, the transceiver interrogates the
25 sensor with RF energy at 915 MHz and close proximity comprises 0.03 m to 0.1 m. Alternatively, the transceiver interrogates the sensor with RF energy at 2.4 GHz and close proximity comprises 0.01 m to 0.05 m.

[0055] In embodiments, the MEMS sensors incorporated into wellbore cement and used to collect data during and/or after cementing the wellbore. The data interrogation tool
30 may be positioned downhole prior to and/or during cementing, for example integrated into a component such as casing, casing attachment, plug, cement shoe, or expanding device. Alternatively, the data interrogation tool is positioned downhole upon completion of

cementing, for example conveyed downhole via wireline. The cementing methods disclosed herein may optionally comprise the step of foaming the cement composition using a gas such as nitrogen or air. The foamed cement compositions may comprise a foaming surfactant and optionally a foaming stabilizer. The MEMS sensors may be incorporated into a sealant composition and placed downhole, for example during primary cementing (e.g., conventional or reverse circulation cementing), secondary cementing (e.g., squeeze cementing), or other sealing operation (e.g., behind an expandable casing).

[0056] In primary cementing, cement is positioned in a wellbore to isolate an adjacent portion of the subterranean formation and provide support to an adjacent conduit (e.g., casing). The cement forms a barrier that prevents fluids (e.g., water or hydrocarbons) in the subterranean formation from migrating into adjacent zones or other subterranean formations. In embodiments, the wellbore in which the cement is positioned belongs to a horizontal or multilateral wellbore configuration. It is to be understood that a multilateral wellbore configuration includes at least two principal wellbores connected by one or more ancillary wellbores.

[0057] FIG. 2, which shows a typical onshore oil or gas drilling rig and wellbore, will be used to clarify the methods of the present disclosure, with the understanding that the present disclosure is likewise applicable to offshore rigs and wellbores. Rig 12 is centered over a subterranean oil or gas formation 14 located below the earth's surface 16. Rig 12 includes a work deck 32 that supports a derrick 34. Derrick 34 supports a hoisting apparatus 36 for raising and lowering pipe strings such as casing 20. Pump 30 is capable of pumping a variety of wellbore compositions (e.g., drilling fluid or cement) into the well and includes a pressure measurement device that provides a pressure reading at the pump discharge. Wellbore 18 has been drilled through the various earth strata, including formation 14. Upon completion of wellbore drilling, casing 20 is often placed in the wellbore 18 to facilitate the production of oil and gas from the formation 14. Casing 20 is a string of pipes that extends down wellbore 18, through which oil and gas will eventually be extracted. A cement or casing shoe 22 is typically attached to the end of the casing string when the casing string is run into the wellbore. Casing shoe 22 guides casing 20 toward the center of the hole and minimizes problems associated with hitting rock ledges or washouts in wellbore 18 as the casing string is lowered into the well. Casing shoe, 22, may be a guide shoe or a float shoe, and typically comprises a tapered, often bullet-nosed piece of equipment found on the

bottom of casing string 20. Casing shoe, 22, may be a float shoe fitted with an open bottom and a valve that serves to prevent reverse flow, or U-tubing, of cement slurry from annulus 26 into casing 20 as casing 20 is run into wellbore 18. The region between casing 20 and the wall of wellbore 18 is known as the casing annulus 26. To fill up casing annulus 26 and secure casing 20 in place, casing 20 is usually "cemented" in wellbore 18, which is referred to as "primary cementing." A data interrogator tool 40 is shown in the wellbore 18.

[0058] In an embodiment, the method of this disclosure is used for monitoring primary cement during and/or subsequent to a conventional primary cementing operation. In this conventional primary cementing embodiment, MEMS sensors are mixed into a cement slurry, block 102 of FIG. 1, and the cement slurry is then pumped down the inside of casing 20, block 104 of FIG. 1. As the slurry reaches the bottom of casing 20, it flows out of casing 20 and into casing annulus 26 between casing 20 and the wall of wellbore 18. As cement slurry flows up annulus 26, it displaces any fluid in the wellbore. To ensure no cement remains inside casing 20, devices called "wipers" may be pumped by a wellbore servicing fluid (e.g., drilling mud) through casing 20 behind the cement. As described in more detail herein, the wellbore servicing fluids such as the cement slurry and/or wiper conveyance fluid (e.g., drilling mud) may contain MEMS sensors which aid in detection and/or positioning of the wellbore servicing fluid and/or a mechanical component such as a wiper plug, casing shoe, etc. The wiper contacts the inside surface of casing 20 and pushes any remaining cement out of casing 20. When cement slurry reaches the earth's surface 16, and annulus 26 is filled with slurry, pumping is terminated and the cement is allowed to set. The MEMS sensors of the present disclosure may also be used to determine one or more parameters during placement and/or curing of the cement slurry. Also, the MEMS sensors of the present disclosure may also be used to determine completion of the primary cementing operation, as further discussed herein below.

[0059] Referring back to FIG. 1, during cementing, or subsequent the setting of cement, a data interrogation tool may be positioned in wellbore 18, as at block 106 of FIG. 1. For example, the wiper may be equipped with a data interrogation tool and may read data from the MEMS while being pumped downhole and transmit same to the surface. Alternatively, an interrogator tool may be run into the wellbore following completion of cementing a segment of casing, for example as part of the drill string during resumed drilling operations. Alternatively, the interrogator tool may be run downhole via a wireline or other

conveyance. The data interrogation tool may then be signaled to interrogate the sensors (block 108 of FIG. 1) whereby the sensors are activated to record and/or transmit data, block 110 of FIG. 1. The data interrogation tool communicates the data to a processor 112 whereby data sensor (and likewise cement slurry) position and cement integrity may be determined via analyzing sensed parameters for changes, trends, expected values, etc. For example, such data may reveal conditions that may be adverse to cement curing. The sensors may provide a temperature profile over the length of the cement sheath, with a uniform temperature profile likewise indicating a uniform cure (e.g., produced via heat of hydration of the cement during curing) or a change in temperature might indicate the influx of formation fluid (e.g., presence of water and/or hydrocarbons) that may degrade the cement during the transition from slurry to set cement. Alternatively, such data may indicate a zone of reduced, minimal, or missing sensors, which would indicate a loss of cement corresponding to the area (e.g., a loss/void zone or water influx/washout). Such methods may be available with various cement techniques described herein such as conventional or reverse primary cementing.

[0060] Due to the high pressure at which the cement is pumped during conventional primary cementing (pump down the casing and up the annulus), fluid from the cement slurry may leak off into existing low pressure zones traversed by the wellbore. This may adversely affect the cement, and incur undesirable expense for remedial cementing operations (e.g., squeeze cementing as discussed hereinbelow) to position the cement in the annulus. Such leak off may be detected via the present disclosure as described previously. Additionally, conventional circulating cementing may be time-consuming, and therefore relatively expensive, because cement is pumped all the way down casing 20 and back up annulus 26.

[0061] One method of avoiding problems associated with conventional primary cementing is to employ reverse circulation primary cementing. Reverse circulation cementing is a term of art used to describe a method where a cement slurry is pumped down casing annulus 26 instead of into casing 20. The cement slurry displaces any fluid as it is pumped down annulus 26. Fluid in the annulus is forced down annulus 26, into casing 20 (along with any fluid in the casing), and then back up to earth's surface 16. When reverse circulation cementing, casing shoe 22 comprises a valve that is adjusted to allow flow into casing 20 and then sealed after the cementing operation is complete. Once slurry is pumped

to the bottom of casing 20 and fills annulus 26, pumping is terminated and the cement is allowed to set in annulus 26. Examples of reverse cementing applications are disclosed in U.S. Pat. Nos. 6,920,929 and 6,244,342, each of which is incorporated herein by reference in its entirety.

5 **[0062]** In embodiments of the present disclosure, sealant slurries comprising MEMS data sensors are pumped down the annulus in reverse circulation applications, a data interrogator is located within the wellbore (e.g., integrated into the casing shoe) and sealant performance is monitored as described with respect to the conventional primary sealing method disclosed hereinabove. Additionally, the data sensors of the present disclosure may
10 also be used to determine completion of a reverse circulation operation, as further discussed hereinbelow.

[0063] Secondary cementing within a wellbore may be carried out subsequent to primary cementing operations. A common example of secondary cementing is squeeze cementing wherein a sealant such as a cement composition is forced under pressure into
15 one or more permeable zones within the wellbore to seal such zones. Examples of such permeable zones include fissures, cracks, fractures, streaks, flow channels, voids, high permeability streaks, annular voids, or combinations thereof. The permeable zones may be present in the cement column residing in the annulus, a wall of the conduit in the wellbore, a microannulus between the cement column and the subterranean formation, and/or a
20 microannulus between the cement column and the conduit. The sealant (e.g., secondary cement composition) sets within the permeable zones, thereby forming a hard mass to plug those zones and prevent fluid from passing therethrough (i.e., prevents communication of fluids between the wellbore and the formation via the permeable zone). Various procedures that may be followed to use a sealant composition in a wellbore are described in U.S. Pat.
25 No. 5,346,012, which is incorporated by reference herein in its entirety. In various embodiments, a sealant composition comprising MEMS sensors is used to repair holes, channels, voids, and microannuli in casing, cement sheath, gravel packs, and the like as described in U.S. Pat. Nos. 5,121,795; 5,123,487; and 5,127,473, each of which is incorporated by reference herein in its entirety.

30 **[0064]** In embodiments, the method of the present disclosure may be employed in a secondary cementing operation. In these embodiments, data sensors are mixed with a sealant composition (e.g., a secondary cement slurry) at block 102 of FIG. 1 and subsequent

or during positioning and hardening of the cement, the sensors are interrogated to monitor the performance of the secondary cement in an analogous manner to the incorporation and monitoring of the data sensors in primary cementing methods disclosed hereinabove. For example, the MEMS sensors may be used to verify that the secondary sealant is functioning properly and/or to monitor its long-term integrity.

5 [0065] In embodiments, the methods of the present disclosure are utilized for monitoring cementitious sealants (e.g., hydraulic cement), non-cementitious (e.g., polymer, latex or resin systems), or combinations thereof, which may be used in primary, secondary, or other sealing applications. For example, expandable tubulars such as pipe, pipe string, casing, liner, or the like are often sealed in a subterranean formation. The expandable tubular (e.g., casing) is placed in the wellbore, a sealing composition is placed into the wellbore, the expandable tubular is expanded, and the sealing composition is allowed to set in the wellbore. For example, after expandable casing is placed downhole, a mandrel may be run through the casing to expand the casing diametrically, with expansions up to 25% possible. The expandable tubular may be placed in the wellbore before or after placing the sealing composition in the wellbore. The expandable tubular may be expanded before, during, or after the set of the sealing composition. When the tubular is expanded during or after the set of the sealing composition, resilient compositions will remain competent due to their elasticity and compressibility. Additional tubulars may be used to extend the wellbore into the subterranean formation below the first tubular as is known to those of skill in the art. Sealant compositions and methods of using the compositions with expandable tubulars are disclosed in U.S. Pat. Nos. 6,722,433 and 7,040,404 and U.S. Pat. Pub. No. 2004/0167248, each of which is incorporated by reference herein in its entirety. In expandable tubular embodiments, the sealants may comprise compressible hydraulic cement compositions and/or non-cementitious compositions.

10 15 20 25 30 [0066] Compressible hydraulic cement compositions have been developed which remain competent (continue to support and seal the pipe) when compressed, and such compositions may comprise MEMS sensors. The sealant composition is placed in the annulus between the wellbore and the pipe or pipe string, the sealant is allowed to harden into an impermeable mass, and thereafter, the expandable pipe or pipe string is expanded whereby the hardened sealant composition is compressed. In embodiments, the compressible foamed sealant composition comprises a hydraulic cement, a rubber latex, a

rubber latex stabilizer, a gas and a mixture of foaming and foam stabilizing surfactants. Suitable hydraulic cements include, but are not limited to, Portland cement and calcium aluminate cement.

[0067] Often, non-cementitious resilient sealants with comparable strength to
5 cement, but greater elasticity and compressibility, are required for cementing expandable casing. In embodiments, these sealants comprise polymeric sealing compositions, and such compositions may comprise MEMS sensors. In an embodiment, the sealants composition comprises a polymer and a metal containing compound. In embodiments, the polymer comprises copolymers, terpolymers, and interpolymers. The metal-containing compounds
10 may comprise zinc, tin, iron, selenium magnesium, chromium, or cadmium. The compounds may be in the form of an oxide, carboxylic acid salt, a complex with dithiocarbamate ligand, or a complex with mercaptobenzothiazole ligand. In embodiments, the sealant comprises a mixture of latex, dithio carbamate, zinc oxide, and sulfur.

[0068] In embodiments, the methods of the present disclosure comprise adding data
15 sensors to a sealant to be used behind expandable casing to monitor the integrity of the sealant upon expansion of the casing and during the service life of the sealant. In this embodiment, the sensors may comprise MEMS sensors capable of measuring, for example, moisture and/or temperature change. If the sealant develops cracks, water influx may thus be detected via moisture and/or temperature indication.

[0069] In an embodiment, the MEMS sensors are added to one or more wellbore
20 servicing compositions used or placed downhole in drilling or completing a monodiameter wellbore as disclosed in U.S. Pat. No. 7,066,284 and U.S. Pat. Pub. No. 2005/0241855, each of which is incorporated by reference herein in its entirety. In an embodiment, the MEMS sensors are included in a chemical casing composition used in a monodiameter wellbore. In
25 another embodiment, the MEMS sensors are included in compositions (e.g., sealants) used to place expandable casing or tubulars in a monodiameter wellbore. Examples of chemical casings are disclosed in U.S. Pat. Nos. 6,702,044; 6,823,940; and 6,848,519, each of which is incorporated herein by reference in its entirety.

[0070] In one embodiment, the MEMS sensors are used to gather data, e.g., sealant
30 data, and monitor the long-term integrity of the wellbore composition, e.g., sealant composition, placed in a wellbore, for example a wellbore for the recovery of natural resources such as water or hydrocarbons or an injection well for disposal or storage. In an

embodiment, data/information gathered and/or derived from MEMS sensors in a downhole wellbore composition e.g., sealant composition, comprises at least a portion of the input and/or output to into one or more calculators, simulations, or models used to predict, select, and/or monitor the performance of wellbore compositions e.g., sealant
5 compositions, over the life of a well. Such models and simulators may be used to select a wellbore composition, e.g., sealant composition, comprising MEMS for use in a wellbore. After placement in the wellbore, the MEMS sensors may provide data that can be used to refine, recalibrate, or correct the models and simulators. Furthermore, the MEMS sensors can be used to monitor and record the downhole conditions that the composition, e.g.,
10 sealant, is subjected to, and composition, e.g., sealant, performance may be correlated to such long term data to provide an indication of problems or the potential for problems in the same or different wellbores. In various embodiments, data gathered from MEMS sensors is used to select a wellbore composition, e.g., sealant composition, or otherwise evaluate or monitor such sealants, as disclosed in U.S. Pat. Nos. 6,697,738; 6,922,637; and
15 7,133,778, each of which is incorporated by reference herein in its entirety.

[0071] In an embodiment, the compositions and methodologies of this disclosure are employed in an operating environment that generally comprises a wellbore that penetrates a subterranean formation for the purpose of recovering hydrocarbons, storing hydrocarbons, injection of carbon dioxide, storage of carbon dioxide, disposal of carbon
20 dioxide, and the like, and the MEMS located downhole (e.g., within the wellbore and/or surrounding formation) may provide information as to a condition and/or location of the composition and/or the subterranean formation. For example, the MEMS may provide information as to a location, flow path/profile, volume, density, temperature, pressure, or a combination thereof of a hydrocarbon (e.g., natural gas stored in a salt dome) or carbon
25 dioxide placed in a subterranean formation such that effectiveness of the placement may be monitored and evaluated, for example detecting leaks, determining remaining storage capacity in the formation, etc. In some embodiments, the compositions of this disclosure are employed in an enhanced oil recovery operation wherein a wellbore that penetrates a subterranean formation may be subjected to the injection of gases (e.g., carbon dioxide) so
30 as to improve hydrocarbon recovery from said wellbore, and the MEMS may provide information as to a condition and/or location of the composition and/or the subterranean formation. For example, the MEMS may provide information as to a location, flow

path/profile, volume, density, temperature, pressure, or a combination thereof of carbon dioxide used in a carbon dioxide flooding enhanced oil recovery operation in real time such that the effectiveness of such operation may be monitored and/or adjusted in real time during performance of the operation to improve the result of same.

5 [0072] Referring to FIG. 4, a method 200 for selecting a sealant (e.g., a cementing composition) for sealing a subterranean zone penetrated by a wellbore according to the present embodiment basically comprises determining a group of effective compositions from a group of compositions given estimated conditions experienced during the life of the well, and estimating the risk parameters for each of the group of effective compositions. In
10 an alternative embodiment, actual measured conditions experienced during the life of the well, in addition to or in lieu of the estimated conditions, may be used. Such actual measured conditions may be obtained for example via sealant compositions comprising MEMS sensors as described herein. Effectiveness considerations include concerns that the sealant composition be stable under downhole conditions of pressure and temperature,
15 resist downhole chemicals, and possess the mechanical properties to withstand stresses from various downhole operations to provide zonal isolation for the life of the well.

[0073] In step 212, well input data for a particular well is determined. Well input data includes routinely measurable or calculable parameters inherent in a well, including vertical depth of the well, overburden gradient, pore pressure, maximum and minimum
20 horizontal stresses, hole size, casing outer diameter, casing inner diameter, density of drilling fluid, desired density of sealant slurry for pumping, density of completion fluid, and top of sealant. As will be discussed in greater detail with reference to step 214, the well can be computer modeled. In modeling, the stress state in the well at the end of drilling, and before the sealant slurry is pumped into the annular space, affects the stress state for the
25 interface boundary between the rock and the sealant composition. Thus, the stress state in the rock with the drilling fluid is evaluated, and properties of the rock such as Young's modulus, Poisson's ratio, and yield parameters are used to analyze the rock stress state. These terms and their methods of determination are well known to those skilled in the art. It is understood that well input data will vary between individual wells. In an alternative
30 embodiment, well input data includes data that is obtained via sealant compositions comprising MEMS sensors as described herein.

[0074] In step 214, the well events applicable to the well are determined. For example, cement hydration (setting) is a well event. Other well events include pressure testing, well completions, hydraulic fracturing, hydrocarbon production, fluid injection, perforation, subsequent drilling, formation movement as a result of producing
5 hydrocarbons at high rates from unconsolidated formation, and tectonic movement after the sealant composition has been pumped in place. Well events include those events that are certain to happen during the life of the well, such as cement hydration, and those events that are readily predicted to occur during the life of the well, given a particular well's location, rock type, and other factors well known in the art. In an embodiment, well events
10 and data associated therewith may be obtained via sealant compositions comprising MEMS sensors as described herein.

[0075] Each well event is associated with a certain type of stress, for example, cement hydration is associated with shrinkage, pressure testing is associated with pressure, well completions, hydraulic fracturing, and hydrocarbon production are associated with
15 pressure and temperature, fluid injection is associated with temperature, formation movement is associated with load, and perforation and subsequent drilling are associated with dynamic load. As can be appreciated, each type of stress can be characterized by an equation for the stress state (collectively "well event stress states"), as described in more detail in U.S. Pat. No. 7,133,778 which is incorporated herein by reference in its entirety.

[0076] In step 216, the well input data, the well event stress states, and the sealant data are used to determine the effect of well events on the integrity of the sealant sheath during the life of the well for each of the sealant compositions. The sealant compositions that would be effective for sealing the subterranean zone and their capacity from its elastic limit are determined. In an alternative embodiment, the estimated effects over the life of
25 the well are compared to and/or corrected in comparison to corresponding actual data gathered over the life of the well via sealant compositions comprising MEMS sensors as described herein. Step 216 concludes by determining which sealant compositions would be effective in maintaining the integrity of the resulting cement sheath for the life of the well.

[0077] In step 218, parameters for risk of sealant failure for the effective sealant
30 compositions are determined. For example, even though a sealant composition is deemed effective, one sealant composition may be more effective than another. In one embodiment, the risk parameters are calculated as percentages of sealant competency

during the determination of effectiveness in step 216. In an alternative embodiment, the risk parameters are compared to and/or corrected in comparison to actual data gathered over the life of the well via sealant compositions comprising MEMS sensors as described herein.

5 **[0078]** Step 218 provides data that allows a user to perform a cost benefit analysis. Due to the high cost of remedial operations, it is important that an effective sealant composition is selected for the conditions anticipated to be experienced during the life of the well. It is understood that each of the sealant compositions has a readily calculable monetary cost. Under certain conditions, several sealant compositions may be equally
10 efficacious, yet one may have the added virtue of being less expensive. Thus, it should be used to minimize costs. More commonly, one sealant composition will be more efficacious, but also more expensive. Accordingly, in step 220, an effective sealant composition with acceptable risk parameters is selected given the desired cost. Furthermore, the overall results of steps 200-220 can be compared to actual data that is obtained via sealant
15 compositions comprising MEMS sensors as described herein, and such data may be used to modify and/or correct the inputs and/or outputs to the various steps 200-220 to improve the accuracy of same.

[0079] As discussed above and with reference to FIG. 2, wipers are often utilized during conventional primary cementing to force cement slurry out of the casing. The wiper
20 plug also serves another purpose: typically, the end of a cementing operation is signaled when the wiper plug contacts a restriction (e.g., casing shoe) inside the casing 20 at the bottom of the string. When the plug contacts the restriction, a sudden pressure increase at pump 30 is registered. In this way, it can be determined when the cement has been displaced from the casing 20 and fluid flow returning to the surface via casing annulus 26
25 stops.

[0080] In reverse circulation cementing, it is also necessary to correctly determine when cement slurry completely fills the annulus 26. Continuing to pump cement into annulus 26 after cement has reached the far end of annulus 26 forces cement into the far end of casing 20, which could incur lost time if cement must be drilled out to continue
30 drilling operations.

[0081] The methods disclosed herein may be utilized to determine when cement slurry has been appropriately positioned downhole. Furthermore, as discussed hereinbelow,

the methods of the present disclosure may additionally comprise using a MEMS sensor to actuate a valve or other mechanical means to close and prevent cement from entering the casing upon determination of completion of a cementing operation.

5 [0082] The way in which the method of the present disclosure may be used to signal when cement is appropriately positioned within annulus 26 will now be described within the context of a reverse circulation cementing operation. FIG. 3 is a flowchart of a method for determining completion of a cementing operation and optionally further actuating a downhole tool upon completion (or to initiate completion) of the cementing operation. This description will reference the flowchart of FIG. 3, as well as the wellbore depiction of FIG. 2.

10 [0083] At block 130, a data interrogation tool as described hereinabove is positioned at the far end of casing 20. In an embodiment, the data interrogation tool is incorporated with or adjacent to a casing shoe positioned at the bottom end of the casing and in communication with operators at the surface. At block 132, MEMS sensors are added to a fluid (e.g., cement slurry, spacer fluid, displacement fluid, etc.) to be pumped into annulus 15 26. At block 134, cement slurry is pumped into annulus 26. In an embodiment, MEMS sensors may be placed in substantially all of the cement slurry pumped into the wellbore. In an alternative embodiment, MEMS sensors may be placed in a leading plug or otherwise placed in an initial portion of the cement to indicate a leading edge of the cement slurry. In an embodiment, MEMS sensors are placed in leading and trailing plugs to signal the 20 beginning and end of the cement slurry. While cement is continuously pumped into annulus 26, at decision 136, the data interrogation tool is attempting to detect whether the data sensors are in communicative (e.g., close) proximity with the data interrogation tool. As long as no data sensors are detected, the pumping of additional cement into the annulus continues. When the data interrogation tool detects the sensors at block 138 indicating that 25 the leading edge of the cement has reached the bottom of the casing, the interrogator sends a signal to terminate pumping. The cement in the annulus is allowed to set and form a substantially impermeable mass which physically supports and positions the casing in the wellbore and bonds the casing to the walls of the wellbore in block 148.

30 [0084] If the fluid of block 130 is the cement slurry, MEMS-based data sensors are incorporated within the set cement, and parameters of the cement (e.g., temperature, pressure, ion concentration, stress, strain, etc.) can be monitored during placement and for the duration of the service life of the cement according to methods disclosed hereinabove.

Alternatively, the data sensors may be added to an interface fluid (e.g., spacer fluid or other fluid plug) introduced into the annulus prior to and/or after introduction of cement slurry into the annulus.

[0085] The method just described for determination of the completion of a primary wellbore cementing operation may further comprise the activation of a downhole tool. For example, at block 130, a valve or other tool may be operably associated with a data interrogator tool at the far end of the casing. This valve may be contained within float shoe 22, for example, as disclosed hereinabove. Again, float shoe 22 may contain an integral data interrogator tool, or may otherwise be coupled to a data interrogator tool. For example, the data interrogator tool may be positioned between casing 20 and float shoe 22. Following the method previously described and blocks 132 to 136, pumping continues as the data interrogator tool detects the presence or absence of data sensors in close proximity to the interrogator tool (dependent upon the specific method cementing method being employed, e.g., reverse circulation, and the positioning of the sensors within the cement flow). Upon detection of a determinative presence or absence of sensors in close proximity indicating the termination of the cement slurry, the data interrogator tool sends a signal to actuate the tool (e.g., valve) at block 140. At block 142, the valve closes, sealing the casing and preventing cement from entering the portion of casing string above the valve in a reverse cementing operation. At block 144, the closing of the valve at 142, causes an increase in back pressure that is detected at the hydraulic pump 30. At block 146, pumping is discontinued, and cement is allowed to set in the annulus at block 148. In embodiments wherein data sensors have been incorporated throughout the cement, parameters of the cement (and thus cement integrity) can additionally be monitored during placement and for the duration of the service life of the cement according to methods disclosed hereinabove.

[0086] In embodiments, systems for sensing, communicating and evaluating wellbore parameters may include the wellbore 18; the casing 20 or other workstring, toolstring, production string, tubular, coiled tubing, wireline, or any other physical structure or conveyance extending downhole from the surface; MEMS sensors 52 that may be placed into the wellbore 18 and/or surrounding formation 14, for example, via a wellbore servicing fluid; and a device or plurality of devices for interrogating the MEMS sensors 52 to gather/collect data generated by the MEMS sensors 52, for transmitting the data from the MEMS sensors 52 to the earth's surface 16, for receiving communications and/or data to the

earth's surface, for processing the data, or any combination thereof, referred to collectively herein a data interrogation/communication units or in some instances as a data interrogator or data interrogation tool. Unless otherwise specified, it is understood that such devices as disclosed in the various embodiments herein will have MEMS sensor interrogation
5 functionality, communication functionality (e.g., transceiver functionality), or both, as will be apparent from the particular embodiments and associated context disclosed herein. The wellbore servicing fluid comprising the MEMS sensors 52 may comprise a drilling fluid, a spacer fluid, a sealant, a fracturing fluid, a gravel pack fluid, a completion fluid, or any other fluid placed downhole. In addition, the MEMS sensors 52 may be configured to measure
10 physical parameters such as temperature, stress and strain, as well as chemical parameters such as CO₂ concentration, H₂S concentration, CH₄ concentration, moisture content, pH, Na⁺ concentration, K⁺ concentration, and Cl⁻ concentration. Various embodiments described herein are directed to interrogation/communication units that are dispersed or distributed at intervals along a length of the casing 20 and form a communication network for
15 transmitting and/or receiving communications to/from a location downhole and the surface, with the further understanding that the interrogation/communication units may be otherwise physically supported by a workstring, toolstring, production string, tubular, coiled tubing, wireline, or any other physical structure or conveyance extending downhole from the surface.

20 **[0087]** Referring to FIG. 5, a schematic view of an embodiment of a wellbore parameter sensing system 600 is illustrated. The wellbore parameter sensing system 600 may comprise the wellbore 18, inside which the casing 20 is situated. In an embodiment, the wellbore parameter sensing system 600 may further comprise a plurality of regional communication units 610, which may be situated on the casing 20 and spaced at regular or
25 irregular intervals along the casing, e.g., about every 5 m to 15 m along the length of the casing 20, alternatively about every 8 m to 12 m along the length of the casing 20, alternatively about every 10 m along the length of the casing 20. In embodiments, the regional communication units 610 may be situated on or in casing collars that couple casing joints together. In addition, the regional communication units 610 may be situated in an
30 interior of the casing 20, on an exterior of the casing 20, or both. In an embodiment, the wellbore parameter sensing system 600 may further comprise a tool (e.g., a data interrogator 620 or other data collection and/or power-providing device), which may be

lowered down into the wellbore 18 on a wireline 622, as well as a processor 630 or other data storage or communication device, which is connected to the data interrogator 620.

5 [0088] In an embodiment, each regional communication unit 610 may be configured to interrogate and/or receive data from, MEMS sensors 52 situated in the annulus 26, in the vicinity of the regional communication unit 610, whereby the vicinity of the regional communication unit 610 is defined as in the above discussion of the wellbore parameter sensing system 300 illustrated in FIG. 5. The MEMS sensors 52 may be configured to transmit MEMS sensor data to neighboring MEMS sensors 52, as denoted by double arrows 632, as well as to transmit MEMS sensor data to the regional communication units 610 in their respective vicinities, as denoted by single arrows 634. In an embodiment, the MEMS sensors 52 may be passive sensors that are powered by bursts of electromagnetic radiation from the regional communication units 610. In a further embodiment, the MEMS sensors 52 may be active sensors that are powered by batteries situated in or on the MEMS sensors 52 or by other downhole power sources.

15 [0089] The regional communication units 610 in the present embodiment of the wellbore parameter sensing system 600 are neither wired to one another, nor wired to the processor 630 or other surface equipment. Accordingly, in an embodiment, the regional communication units 610 may be powered by batteries, which enable the regional communication units 610 to interrogate the MEMS sensors 52 in their respective vicinities and/or receive MEMS sensor data from the MEMS sensors 52 in their respective vicinities. The batteries of the regional communication units 610 may be inductively rechargeable by the data interrogator 620 or may be rechargeable by other downhole power sources. In addition, as set forth above, the data interrogator 620 may be lowered into the wellbore 18 for the purpose of interrogating regional communication units 610 and receiving the MEMS sensor data stored in the regional communication units 610. Furthermore, the data interrogator 620 may be configured to transmit the MEMS sensor data to the processor 630, which processes the MEMS sensor data. In an embodiment, a fluid containing MEMS in contained within the wellbore casing (for example, as shown in FIGS. 5, 6, 7, and 10), and the data interrogator 620 is conveyed through such fluid and into communicative proximity with the regional communication units 610. In various embodiments, the data interrogator 620 may communicate with, power up, and/or gather data directly from the various MEMS sensors distributed within the annulus 26 and/or the casing 20, and such direct interaction

with the MEMS sensors may be in addition to or in lieu of communication with one or more of the regional communication units 610. For example, if a given regional communication unit 610 experiences an operational failure, the data interrogator 620 may directly communicate with the MEMS within the given region experiencing the failure, and thereby
5 serve as a backup (or secondary/verification) data collection option.

[0090] Referring to FIG. 6, a schematic view of an embodiment of a wellbore parameter sensing system 700 is illustrated. As in earlier-described embodiments, the wellbore parameter sensing system 700 comprises the wellbore 18 and the casing 20 that is situated inside the wellbore 18. In addition, as in the case of other embodiments illustrated
10 in FIG. 5, the wellbore parameter sensing system 700 comprises a plurality of regional communication units 710, which may be situated on the casing 20 and spaced at regular or irregular intervals along the casing, e.g., about every 5 m to 15 m along the length of the casing 20, alternatively about every 8 m to 12 m along the length of the casing 20, alternatively about every 10 m along the length of the casing 20. In embodiments, the
15 regional communication units 710 may be situated on or in casing collars that couple casing joints together. In addition, the regional communication units 710 may be situated in an interior of the casing 20, on an exterior of the casing 20, or both, or may be otherwise located and supported as described in various embodiments herein.

[0091] In an embodiment, the wellbore parameter sensing system 700 further
20 comprises one or more primary (or master) communication units 720. The regional communication units 710a and the primary communication unit 720a may be coupled to one another by a data line 730, which allows sensor data obtained by the regional communication units 710a from MEMS sensors 52 situated in the annulus 26 to be transmitted from the regional communication units 710a to the primary communication
25 unit 720a, as indicated by directional arrows 732.

[0092] In an embodiment, the MEMS sensors 52 may sense at least one wellbore parameter and transmit data regarding the at least one wellbore parameter to the regional communication units 710b, either via neighboring MEMS sensors 52 as denoted by double
30 arrow 734, or directly to the regional communication units 710 as denoted by single arrows 736. The regional communication units 710b may communicate wirelessly with the primary or master communication unit 720b, which may in turn communicate wirelessly with equipment located at the surface (or via telemetry such as casing signal telemetry) and/or

other regional communication units 720a and/or other primary or master communication units 720a.

[0093] In embodiments, the primary or master communication units 720 gather information from the MEMS sensors and transmit (e.g., wirelessly, via wire, via telemetry such as casing signal telemetry, etc.) such information to equipment (e.g., processor 750) located at the surface.

[0094] In an embodiment, the wellbore parameter sensing system 700 further comprises, additionally or alternatively, a data interrogator 740, which may be lowered into the wellbore 18 via a wire line 742, as well as a processor 750, which is connected to the data interrogator 740. In an embodiment, the data interrogator 740 is suspended adjacent to the primary communication unit 720, interrogates the primary communication unit 720, receives MEMS sensor data collected by all of the regional communication units 710 and transmits the MEMS sensor data to the processor 750 for processing. The data interrogator 740 may provide other functions, for example as described with reference to data interrogator 620 of FIG. 5. In various embodiments, the data interrogator 740 (and likewise the data interrogator 620) may communicate directly or indirectly with any one or more of the MEMS sensors (e.g., sensors 52), local or regional data interrogation/communication units (e.g., units 310, 510, 610, 710), primary or master communication units (e.g., units 720), or any combination thereof.

[0095] Referring to FIG. 7, a schematic view of an embodiment of a wellbore parameter sensing system 800 is illustrated. As in earlier-described embodiments, the wellbore parameter sensing system 800 comprises the wellbore 18 and the casing 20 that is situated inside the wellbore 18. In addition, as in the case of other embodiments shown in FIGS. 5 and 6, the wellbore parameter sensing system 800 comprises a plurality of local, regional, and/or primary/master communication units 810, which may be situated on the casing 20 and spaced at regular or irregular intervals along the casing 20, e.g., about every 5 m to 15 m along the length of the casing 20, alternatively about every 8 m to 12 m along the length of the casing 20, alternatively about every 10 m along the length of the casing 20. In embodiments, the communication units 810 may be situated on or in casing collars that couple casing joints together. In addition, the communication units 810 may be situated in an interior of the casing 20, on an exterior of the casing 20, or both, or may be otherwise located and supported as described in various embodiments herein.

[0096] In an embodiment, MEMS sensors 52, which are present in a wellbore servicing fluid that has been placed in the wellbore 18, may sense at least one wellbore parameter and transmit data regarding the at least one wellbore parameter to the local, regional, and/or primary/master communication units 810, either via neighboring MEMS sensors 52 as denoted by double arrows 812, 814, or directly to the communication units 810 as denoted by single arrows 816, 818.

[0097] In an embodiment, the wellbore parameter sensing system 800 may further comprise a data interrogator 820, which is connected to a processor 830 and is configured to interrogate each of the communication units 810 for MEMS sensor data via a ground penetrating signal 822 and to transmit the MEMS sensor data to the processor 830 for processing.

[0098] In a further embodiment, one or more of the communication units 810 may be coupled together by a data line (e.g., wired communications). In this embodiment, the MEMS sensor data collected from the MEMS sensors 52 by the regional communication units 810 may be transmitted via the data line to, for example, the regional communication unit 810 situated furthest uphole. In this case, only one regional communication unit 810 is interrogated by the surface located data interrogator 820. In addition, since the regional communication unit 810 receiving all of the MEMS sensor data is situated uphole from the remainder of the regional communication units 810, an energy and/or parameter (intensity, strength, wavelength, amplitude, frequency, etc.) of the ground penetrating signal 822 may be able to be reduced. In other embodiments, a data interrogator such as unit 620 or 740) may be used in addition to or in lieu of the surface unit 810, for example to serve as a back-up in the event of operation difficulties associated with surface unit 820 and/or to provide or serve as a relay between surface unit 820 and one or more units downhole such as a regional unit 810 located at an upper end of a string of interrogator units.

[0099] For sake of clarity, it should be understood that like components as described in any of FIGS. 5-7 may be combined and/or substituted to yield additional embodiments and the functionality of such components in such additional embodiments will be apparent based upon the description of FIGS. 5-7 and the various components therein. For example, in various embodiments disclosed herein (including but not limited to the embodiments of FIGS. 5-7), the local, regional, and/or primary/master communication/data interrogation units (e.g., units 310, 510, 610, 620, 710, 740, and/or 810) may communicate with one

another and/or equipment located at the surface via signals passed using a common structural support as the transmission medium (e.g., casing, tubular, production tubing, drill string, etc.), for example by encoding a signal using telemetry technology such as an electrical/mechanical transducer. In various embodiments disclosed herein (including but not limited to the embodiments of FIGS. 5-7), the local, regional, and/or primary/master communication/data interrogation units (e.g., units 310, 510, 610, 620, 710, 740, and/or 810) may communicate with one another and/or equipment located at the surface via signals passed using a network formed by the MEMS sensors (e.g., a daisy-chain network) distributed along the wellbore, for example in the annular space 26 (e.g., in a cement) and/or in a wellbore servicing fluid inside casing 20. In various embodiments disclosed herein (including but not limited to the embodiments of FIGS. 5-7), the local, regional, and/or primary/master communication/data interrogation units (e.g., units 310, 510, 610, 620, 710, 740, and/or 810) may communicate with one another and/or equipment located at the surface via signals passed using a ground penetrating signal produced at the surface, for example being powered up by such a ground-penetrating signal and transmitting a return signal back to the surface via a reflected signal and/or a daisy-chain network of MEMS sensors and/or wired communications and/or telemetry transmitted along a mechanical conveyance/medium. In some embodiments, one or more of), the local, regional, and/or primary/master communication/data interrogation units (e.g., units 310, 510, 610, 620, 710, 740, and/or 810) may serve as a relay or broker of signals/messages containing information/data across a network formed by the units and/or MEMS sensors.

[00100] Referring to FIG. 8, a method 900 of servicing a wellbore is described. At block 910, a plurality of MEMS sensors is placed in a wellbore servicing fluid. At block 920, the wellbore servicing fluid is placed in a wellbore. At block 930, data is obtained from the MEMS sensors, using a plurality of data interrogation units spaced along a length of the wellbore. At block 940, the data obtained from the MEMS sensors is processed.

[00101] Referring to FIG. 9, a further method 1000 of servicing a wellbore is described. At block 1010, a plurality of MEMS sensors is placed in a wellbore servicing fluid. At block 1020, the wellbore servicing fluid is placed in a wellbore. At block 1030, a network consisting of the MEMS sensors is formed. At block 1040, data obtained by the MEMS sensors is transferred from an interior of the wellbore to an exterior of the wellbore via the network consisting of the MEMS sensors. Any of the embodiments set forth in the Figures

described herein, for example, without limitation, FIGS. 5-7, may be used in carrying out the methods as set forth in FIGS. 8 and 9.

[00102] In some embodiments, a conduit (e.g., casing 20 or other tubular such as a production tubing, drill string, workstring, or other mechanical conveyance, etc.) in the wellbore 18 may be used as a data transmission medium, or at least as a housing for a data transmission medium, for transmitting MEMS sensor data from the MEMS sensors 52 and/or interrogation/communication units situated in the wellbore 18 to an exterior of the wellbore (e.g., earth's surface 16). Again, it is to be understood that in various embodiments referencing the casing, other physical supports may be used as a data transmission medium such as a workstring, toolstring, production string, tubular, coiled tubing, wireline, jointed pipe, or any other physical structure or conveyance extending downhole from the surface.

[00103] Referring to FIG. 10, a schematic cross-sectional view of an embodiment of the casing 1120 is illustrated. The casing 1120 may comprise a groove, cavity, or hollow 1122, which runs longitudinally along an outer surface 1124 of the casing, along at least a portion of a length of the 1120 casing. The groove 1122 may be open or may be enclosed, for example with an exterior cover applied over the groove and attached to the casing (e.g., welded) or may be enclosed as an integral portion of the casing body/structure (e.g., a bore running the length of each casing segment). In an embodiment, at least one cable 1130 may be embedded or housed in the groove 1122 and run longitudinally along a length of the groove 1122. The cable 1130 may be insulated (e.g., electrically insulated) from the casing 1120 by insulation 1132. The cable 1130 may be a wire, fiber optic, or other physical medium capable of transmitting signals.

[00104] In an embodiment, a plurality of cables 1130 may be situated in groove 1122, for example, one or more insulated electrical lines configured to power pieces of equipment situated in the wellbore 18 and/or one or more data lines configured to carry data signals between downhole devices and an exterior of the wellbore 18. In various embodiments, the cable 1130 may be any suitable electrical, signal, and/or data communication line, and is not limited to metallic conductors such as copper wires but also includes fiber optical cables and the like.

[00105] FIG. 11 illustrates an embodiment of a wellbore parameter sensing system 1100, comprising the wellbore 18 inside which a wellbore servicing fluid loaded with MEMS sensors 52 is situated; the casing 1120 having a groove 1122; a plurality of data

interrogation/communication units 1140 situated on the casing 1120 and spaced along a length of the casing 1120; a processing unit 1150 situated at an exterior of the wellbore 18; and a power supply 1160 situated at the exterior of the wellbore 18.

[00106] In embodiments, the data interrogation/communication units 1140 may be situated on or in casing collars that couple casing joints together. In addition or alternatively, the data interrogation/communication units 1140 may be situated in an interior of the casing 1120, on an exterior of the casing 1120, or both. In an embodiment, the data interrogation/communication units 1140a may be connected to the cable(s) and/or data line(s) 1130 via through-holes 1134 in the insulation 1132 and/or the casing (e.g., outer surface 1124). The data interrogation/communication units 1140a may be connected to the power supply 1160 via cables 1130, as well as to the processor 1150 via data line(s) 1133. The data interrogation/communication units 1140a commonly connected to one or more cables 1130 and/or data lines 1133 may function (e.g., collect and communication MEMS sensor data) in accordance with any of the embodiments disclosed herein having wired connections/communications, including but not limited to FIG. 6. Furthermore, the wellbore parameter sensing system 1100 may further comprise one or more data interrogation/communication units 1140b in wireless communication and may function (e.g., collect and communication MEMS sensor data) in accordance with any of the embodiments disclosed herein having wireless connections/communications, including but not limited to FIGS. 5-7.

[00107] By way of non-limiting example, the MEMS sensors 52 present in a wellbore servicing fluid situated in an interior of the casing 1120 and/or in the annulus 26 measure at least one wellbore parameter. The data interrogation/communication units 1140 in a vicinity of the MEMS sensors 52 interrogate the sensors 52 at regular intervals and receive data from the sensors 52 regarding the at least one wellbore parameter. The data interrogation/communication units 1140 then transmit the sensor data to the processor 1150, which processes the sensor data.

[00108] In an embodiment, the MEMS sensors 52 may be passive tags, i.e., may be powered, for example, by bursts of electromagnetic radiation from sensors of the regional data interrogation/communication units 1140. In a further embodiment, the MEMS sensors 52 may be active tags, i.e., powered by a battery or batteries situated in or on the tags 52 or

other downhole power source. In an embodiment, batteries of the MEMS sensors 52 may be inductively rechargeable by the regional data interrogation/communication units 1140.

[00109] In a further embodiment, the casing 1120 may be used as a conductor for powering the data interrogation/communication units 1140, or as a data line for transmitting MEMS sensor data from the data interrogation/communication units 1140 to the processor 1150.

[00110] FIG. 12 illustrates an embodiment of a wellbore parameter sensing system 1200, comprising the wellbore 18 inside which a wellbore servicing fluid loaded with MEMS sensors 52 is situated; the casing 20; a plurality of data interrogation/communication units 1210 situated on the casing 20 and spaced along a length of the casing 20; and a processing unit 1220 situated at an exterior of the wellbore 18.

[00111] In embodiments, the data interrogation/communication units 1210 may be situated on or in casing collars that couple casing joints together. In addition or alternatively, the data interrogation/communication units 1210 may be situated in an interior of the casing 20, on an exterior of the casing 20, or both. In embodiments, the data interrogation/communication units 1210 may each comprise an acoustic transmitter, which is configured to convert MEMS sensor data received by the data interrogation/communication units 1210 from the MEMS sensors 52 into acoustic signals that take the form of acoustic vibrations in the casing 20, which may be referred to as acoustic telemetry embodiments. In embodiments, the acoustic transmitters may operate, for example, on a piezoelectric or magnetostrictive principle and may produce axial compression waves, torsional waves, radial compression waves or transverse waves that propagate along the casing 20 in an uphole direction denoted by arrows 1212. A discussion of acoustic transmitters as part of an acoustic telemetry system is given in U.S. Patent Application Publication No. 2010/0039898 and U.S. Pat. Nos. 3,930,220; 4,156,229; 4,298,970; and 4,390,975, each of which is hereby incorporated by reference in its entirety. In addition, the data interrogation/communication units 1210 may be powered as described herein in various embodiments, for example by internal batteries that may be inductively rechargeable by a recharging unit run into the wellbore 18 on a wireline or by other downhole power sources.

[00112] In embodiments, the wellbore parameter sensing system 1200 further comprises at least one acoustic receiver 1230, which is situated at or near an uphole end of

the casing 20, receives acoustic signals generated and transmitted by the acoustic transmitters, converts the acoustic signals into electrical signals and transmits the electrical signals to the processing unit 1220. Arrows 1232 denote the reception of acoustic signals by acoustic receiver 1230. In an embodiment, the acoustic receiver 1230 may be powered by an electrical line running from the processing unit 1220 to the acoustic receiver 1230.

5 [00113] In embodiments, the wellbore parameter sensing system 1200 further comprises a repeater 1240 situated on the casing 20. The repeater 1240 may be configured to receive acoustic signals from the data interrogation/communication units 1210 situated downhole from the repeater 1240, as indicated by arrows 1242. In addition, the repeater 10 1240 may be configured to retransmit, to the acoustic receiver 1230, acoustic signals regarding the data received by these downhole data interrogation/communication units 1210 from MEMS sensors 52. Arrows 1244 denote the retransmission of acoustic signals by repeater 1240. In further embodiments, the wellbore parameter sensing system 1200 may comprise multiple repeaters 1240 spaced along the casing 20. In various embodiments, the 15 data interrogation/communication units 1210 and/or the repeaters 1240 may contain suitable equipment to encode a data signal into the casing 20 (e.g. electrical/mechanical transducing circuitry and equipment).

[00114] In operation, in an embodiment, the MEMS sensors 52 situated in the interior of the casing 20 and/or in the annulus 26 may measure at least one wellbore parameter and 20 then transmit data regarding the at least one wellbore parameter to the data interrogation/communication units 1210 in their respective vicinities in accordance with the various embodiments disclosed herein, including but not limited to FIGS. 5-9. The acoustic transmitters in the data interrogation/communication units 1210 may convert the MEMS sensor data into acoustic signals that propagate up the casing 20. The repeater or repeaters 25 1240 may receive acoustic signals from the data interrogation/communication units 1210 downhole from the respective repeater 1240 and retransmit acoustic signals further up the casing 20. At or near an uphole end of the casing 20, the acoustic receiver 1230 may receive the acoustic signals propagated up the casing 20, convert the acoustic signals into electrical signals and transmit the electrical signals to the processing unit 1220. The processing unit 30 1220 then processes the electrical signals. In various embodiments, the acoustic telemetry embodiments and associated equipment may be combined with a network formed by the MEMS sensors and/or data interrogation/communication units (e.g., a point to point or

"daisy-chain" network comprising MEMS sensors) to provide back-up or redundant wireless communication network functionality for conveying MEMS data from downhole to the surface. Of course, such wireless communications and networks could be further combined with various wired embodiments disclosed herein for further operational advantages.

5 [00115] Referring to FIG. 13, a method 1300 of servicing a wellbore is described. At block 1310, a plurality of MEMS sensors is placed in a wellbore servicing fluid. At block 1320, the wellbore servicing fluid is placed in a wellbore. At block 1330, data is obtained from the MEMS sensors, using a plurality of data interrogation units spaced along a length of the wellbore. At block 1340, the data is telemetrically transmitted from an interior of the
10 wellbore to an exterior of the wellbore, using a casing situated in the wellbore (e.g., via acoustic telemetry). At block 1350, the data obtained from the MEMS sensors is processed.

Azimuthally Sensitive Measurements

[00116] As noted above regarding FIGs. 1 and 3-4, it can be advantageous to
15 determine the progress or possible completion of a sealing (or "cementing") operation, which can be accomplished by taking measurements along the casing string of the location and progress of the "top of cement" (TOC). It can also be advantageous to monitor the quality of sealant as a barrier, which includes the adequacy of the distribution of sealant throughout the annulus between the casing and the formation. FIG. 14 is a cross-sectional
20 schematic view of an example communication assembly 1400 as may be used to measure the sealant (or other well servicing fluids) present within different azimuthal regions of the annulus. Communication assembly 1400 is discussed below with reference to some elements depicted in FIG. 5-7.

[00117] The example communication assembly 1400 includes a plurality of ribs 1402
25 that extend longitudinally along the assembly and in spaced relation to one another around the periphery of the assembly. In many examples, ribs 1402 will be hollow and will house control circuitry or other electronics, for example, voltage-controlled oscillators, memory, analog RF circuitry, sensors, power systems, processors, and other circuitry to enable communication with an external location, etc.

30 [00118] In this example, the ribs 1402 will further include interrogation circuitry suitable for generating signals to both interrogate RFID tags (which may include additional MEMS sensor components, as described earlier herein) and to receive signals from those

interrogated RFID tags. Such signals will be communicated to one or more antennas 1404 operatively coupled to each instance of such interrogation circuitry). An instance of interrogation circuitry with at least one antenna will form a "RFID sensor assembly" for sensing the presence of RFID tags, and any additional information obtained when the RFID tags are interrogated (such as sensor data).

5 [00119] These RFID sensor assemblies can be of a variety of configurations. As one example, tags may be interrogated through an RFID sensor assembly using a single antenna to both send interrogation signals to RFID tags and receive response signals from such tags. In other examples, an RFID sensor assembly may be configured to use two antennas, one for transmitting the interrogation signals and the other for receiving the response signals. Each 10 RFID sensor assembly (as defined below), includes at least one antenna and the identified interrogation circuitry; however, each RFID sensor assembly will not necessarily include a discrete instance of the interrogation circuitry. For example, the interrogation circuitry can be configured to send/receive signals through multiple antennas, or through multiple pairs 15 of antennas (depending on the RFID sensor assembly configuration). As will be apparent to persons skilled in the art, this functionality can be achieved through multiple mechanisms, for example, such as time shifting signals communicated to each antenna, or pair of antennas. In other words, in some examples, multiple RFID sensor assemblies may share a single physical instance of interrogation circuitry.

20 [00120] Accordingly, each antenna (in a single antenna send/receive assembly), or each pair of antennas (in a dual antenna send-receive assembly) used to communicate with RFID tags will be referred to as a "RFID sensor assembly" herein, with the understanding that the antennas will be operably coupled to a discrete or shared instance of interrogation circuitry to form the complete RFID sensor assembly. As will be apparent to persons skilled 25 in the art, the location and orientation of the antenna(s) will in substantial part control the area interrogated by the RFID sensor assembly. Therefore, the location of each single antenna or pair of antenna operated by the interrogation circuitry to interrogate RFID tags will be identified as the "location" of the RFID sensor assembly, notwithstanding that the associated interrogation circuitry may be placed at a different physical location.

30 [00121] The various electronic circuits within each rib 1402 can be configured to communicate as desired with circuitry in another rib 1402. Such communications between can occur through use of any suitable mechanism as will be apparent to those skilled in the

art, for example, through use of a serial peripheral interface (SPI), though embodiments are not limited thereto.

[00122] Communication assembly 1400 can be configured to be associated with the casing string by a variety of mechanisms. Each communication assembly includes a body member 1418 supporting other components and facilitating association with the casing string. In some embodiments, communication assembly 1400 will include a sleeve body member configured to concentrically engage the outer diameter of a length of casing. In such cases, the sleeve body member can be placed over a length of casing before it is incorporated into the casing string 20, and then secured in place by an appropriate mechanism. As one example, the sleeve body member may be secured against the upset at the box end of the casing section and then clamped in place. In other examples, communication assembly 1400 can include a body member configured as a specialized section of casing 20, which either includes ribs 1402 as depicted in FIG. 14, or provides recesses or other structures to house the described components, and configured to be threadably inserted into the casing string 20. In yet another alternative, communication assembly 1400 can have a supporting body member configured as a hinged clamshell (or a two part assembly) that can be secured around a length of casing, without either having to be joined into the casing string or the casing having to be inserted through the body member, as with the above alternative examples.

[00123] One consideration in the configuration of communication assembly 1400 will be the structures used for communicating information from the communication assembly. In some examples where communication is through wireless RF communication, the communication assembly may include either a toroidal coil with a core extending circumferentially to the assembly (and casing), or a solenoid coil with windings extending circumferentially around the assembly (and casing string) to transmit the communication signals. Such assemblies may be more difficult to implement in either a clamshell or a multi-section form, relative to solid body member configurations such as the above examples.

[00124] Referring again to FIG. 14, example communication assembly 1400 includes four ribs 1402 generally equally spaced around assembly, and therefore equally spaced relative to the circumference of casing 20. As will be apparent to persons skilled in the art having the benefit of this disclosure, either a greater or lesser number of ribs may be utilized as desired for particular application. In the depicted schematic representation, a pair of

antennas is provided between each pair of adjacent ribs 1402 to sense RFID tags contained within fluid passing by communication assembly 1400 in the well annulus. In the depicted example, the RFID sensor assemblies are presumed to be of a dual antenna configuration, and thus each pair of antennas between ribs, 1404 A-B, 1404 C-D, 1404 E-F and 1404 G-H, is intended to form a respective RFID sensor assembly under the definition provided above. In other examples, each antenna may represent a separate RFID sensor assembly. Because of the dual antenna RFID sensor assembly configuration assumed in communication assembly 1400, each RFID sensor assembly will interrogate RFID tags within a respective azimuthal quadrant of the annulus surrounding communication assembly 1400 in a well. Any number of ribs, or corresponding structures, may be provided as necessary to house the necessary circuitry, and as desired to provide interrogation within a determined azimuthal region surrounding communication assembly 1400. It should be clearly understood that azimuthal detection is not limited to space between the ribs (or corresponding structures). In some examples, RFID sensor assemblies may be located to sense "across" each rib to maximize azimuthal sensing of the annulus.

[00125] Each RFID sensor assembly will often be configured to detect generally within a determined azimuthal region of the annulus. In some implementations, these azimuthal regions may all be distinguished from one another, while in others the azimuthal regions may partially overlap with one another. Additionally, each communication assembly may provide multiple longitudinally offset RFID sensor assemblies, providing redundant sensing within a given azimuthal region. Of course, in many contemplated configurations, multiple communication assemblies longitudinally disposed along the casing string will measure corresponding azimuthal regions as other communication assemblies, albeit at different depths within the borehole.

[00126] For the present example, communication assembly 1400 includes four RFID sensor assemblies, as noted above. However, additional ribs may be provided, and may be used to support additional antennas in desired orientations; and/or additional RFID sensor assemblies might be longitudinally offset along communication assembly 1400 relative to those depicted in FIG. 14 (see FIG. 15 B). Additionally, as discussed below, each communication assembly can include one or more sensors of types other than RFID sensors. Examples (as described later herein), include acoustic sensors, temperature sensors, etc. In many (but not all) examples, these additional sensors will also be arranged to sense

parameters in a selected azimuthal region of the annulus surrounding the communication assembly. In the case of some types of sensors, it may be determined that only a single measurement is need proximate a given depth, and thus only a single additional sensor of a selected type may be used, rather than multiple azimuthally sensitive sensors of that type.

5 As with the RFID sensor assemblies, in many embodiments of such systems, the circuitry associated with such additional sensors (for control, receiving, and/or processing of data from the sensors), and in some cases, the entire sensor itself, will be housed within one or more of ribs 1402.

[00127] Referring now to FIGs. 15A-C, these figures each depict a side view of a
10 respective example of a communication assembly 1420, 1430, 1440, respectively. Components comparable to those discussed relative to FIG. 14 are numbered similarly in FIGs. 15A-C. In the depicted examples, each communication assembly 1420, 1430, 1440 includes a plurality of antennas arranged to provide a plurality of RFID sensor assemblies, though only one side of each communication assembly is shown. Accordingly, it should be
15 understood that the described structures would be replicated at a plurality of azimuthally offset locations around each communication assembly 1420, 1430, 1440. Each antenna 1404 can be configured as a loop, dipole, etc., as desired. For the present examples, the antennas 1404 are each depicted as a loop antenna, again in a dual antenna RFID sensor assembly configuration. Each antenna may be oriented on the respective communication
20 assembly 1420, 1430, 1440, as desired to orient the field of the antenna in a desired direction.

[00128] Depending upon the specific materials of construction of various portions of a respective communication assembly, antennas may be secured proximate a metallic surface. In such cases, the antennas can be mounted on a dielectric material 1406 to
25 prevent electrical shorts against such metallic surfaces of the communication assemblies. In many cases, this dielectric material can be of any type generally known to persons skilled in the art for electrically isolating and protecting electrical components within downhole tools. For example, a material such as Protech DRB™ or Protech CRB™, available from the Halliburton Company of Houston, Texas can be used as a suitable dielectric material 1406.
30 In general, the dielectric material is one capable of providing a necessary degree of mechanical protection for the covered components, while providing a high resistance to DC current, but a low electrical loss factor to signals in the 10MHz to 1 GHz range. The same

dielectric material 1406, or another suitable material, can be disposed over antennas 1404 to protect them from the harsh environment within a borehole, including risk of abrasion, chemically induced deterioration, etc.

[00129] As noted above, in the dual antenna configuration of the RFID sensor assemblies, one antenna 1404 of a pair will transmit RF signals to interrogate RFID tags from one antenna and the other antenna 1404 of the pair will be used to receive signals generated from the RFID tags in response to the interrogation signal. A compatible RFID tag (not shown in FIG. 15A) passing in the field between the pair of antennas 1404 will generate a change in the transmission pattern between antennas 1404 in response to the interrogation signal.

[00130] In the dual antenna RFID sensor assembly configuration as described earlier, the antennas can be arranged such that they define a generally known region of investigation for the respective RFID sensor assembly. In the example of communication assembly 1420 of FIG. 15A, antennas 1412 and 1414 can be oriented to provide a region of investigation extending generally between the adjacent ribs 1402. As a result, the RFID sensor assembly with antennas 1412 and 1414 will investigate approximately a quadrant of the annulus surrounding communication assembly 1420, up to a maximum depth of investigation as determined by the specific implementation. Monitoring the number of tags identified by that RFID sensor assembly provides an indication of the volume of fluid in which those RFID tags are carried proximate the quadrant investigated by the RFID sensor assembly. In other configurations, such as single antenna RFID sensor assemblies, the location of the antenna, in combination with an experimentally determined region of investigation, can again provide a measure of fluid within azimuthal region of investigation of the RFID sensor assembly. In these types of measurements, the primary concern is as to the number of tags within an identifiable region rather than the placement of any individual tag. Such a system can be implemented with relatively basic passive RFID tags that merely respond to an interrogation rather than transmitting a tag ID or other information.

[00131] In interrogating the RFID tags, interrogation circuitry within rib 1402, as described above regarding FIG. 14, can, in some examples, interrogate the RFID tags by scanning through a range of possible tag frequencies, in a manner of RFID tag interrogation known to those skilled in the art. In some examples, the interrogation circuitry will be configured to determine a location of the tag with respect to the antennas by more complex

methodologies, such as through evaluating the amplitude of a signal reflected from the tag and/or triangulation through interrogation of a tag by multiple RFID sensor assemblies. In many of these example implementations it will be preferable that the RFID tags each have a unique tag ID, enabling the tag to be individually distinguished. In such systems,

5 interrogation circuitry within rib 1402 can be configured detect azimuthal direction of a tag based on a transmission pattern or amplitude of a reflected signal between a tag and one or more antennas 1404. Therefore, the nature or type of fluid in which tags are disposed can again be detected at different azimuthal directions relative to communication assembly 1400 and casing 20.

10 **[00132]** Many possible arrangements of antennas are contemplated, and the described system is not limited to any particular configuration of antennas. The number, arrangement and spacing of antennas can be adjusted based on, for example, power needs, performance requirements, or borehole conditions.

[00133] As noted above, the communication assemblies may include a coil that
15 extends in either a toroidal or solenoid form concentrically to the casing to facilitate wireless communication of obtained data. An example coil 1408 is depicted in each of communication assemblies 1420, 1430, 1440.

[00134] Later herein, in reference to FIG. 18, the inclusion of an acoustic transceiver (1856) in an interrogation/communication unit (1810) was described. The described
20 acoustic transceiver 1856 includes an acoustic sensor 1852 configured to direct ultrasonic waves into the wellbore servicing fluid 1830 and to receive reflected waves. Acoustic transceiver 1856, also includes an acoustic transmitter 1860 and an acoustic receiver 1858, and as well as a microprocessor 1862 for providing the control functions to both transmit
25 the acoustic signals and receive signals from the receivers. As depicted in FIG. 15A at 1856A –B, example communication assembly 1420 includes a plurality of such acoustic transceivers deployed circumferentially around the assembly. In the depicted example, the acoustic transceivers are placed between the ribs 1402. In some implementations, the acoustic transceivers will have a thickness that would undesirably take up additional radial space relative to the body member 1408, as to make their placement between the ribs less than
30 optimal. In such cases acoustic transceivers 1856A-B may be incorporated into the ribs 1402. Subject to spatial limitations and practical considerations such as diminishing value to additional sensors, any number of such acoustic transceivers may be included in each

communication assembly 1420 in spaced relation around the circumference of body member 1408.

[00135] Referring now to FIG 15B, the figure depicts an alternative configuration of the communication assembly 1430. Communication assembly 1430 includes an RFID sensor assembly including one antenna 1432 oriented along one rib 1402, with a paired antenna oriented at an angle such as by being placed generally in a plane tangential to body member 1408 of the communication assembly (i.e., in this example extending generally in parallel to a tangent of the underlying casing string). In this example, a second similarly arranged RFID sensor assembly having a pair of antennas 1436, 1438 is included at a longitudinally offset location along body member 1408.

[00136] FIG. 15C depicts an alternative configuration of a communication assembly 1440 in which an antenna 1446 is placed in a generally central location between two ribs 1402 to serve as either a transmit or receive antenna relative to a pair of nearby antennas 1442, 1444. Antennas 1442, 1444 may be mounted, for example, on the adjacent ribs 1402, and configured to perform the opposite transmit/receive function. Thus, the central antenna 1446 is shared by two RFID sensor assemblies each having antenna 1442 or 1444 as the other antenna. In some implementations, this configuration may serve to provide increased certainty of investigation across an azimuthal region of the surrounding annulus.

[00137] Turning to Fig. 18, the figure illustrates an embodiment of a portion of a wellbore parameter sensing system 1800. The wellbore parameter sensing system 1800 comprises the wellbore 18, the casing 20 situated in the wellbore 18, a plurality of regional communication units 1810 attached to the casing 20 and spaced along a length of the casing 20, a processing unit 1820 situated at an exterior of the wellbore and communicatively linked to the units 1810, and a wellbore servicing fluid 1830 situated in the wellbore 18. The wellbore servicing fluid 1830 may comprise a plurality of MEMS sensors 1840, which are configured to measure at least one wellbore parameter. In an embodiment, FIG. 18 represents a regional communication unit 1810 located on an exterior of the casing 20 in annular space 26 and surrounded by a cement composition comprising MEMS sensors. The unit 1810 may further comprise a power source, for example a battery (e.g., lithium battery) or power generator.

[00138] In an embodiment, the unit 1810 may comprise an interrogation unit 1850, which is configured to interrogate the MEMS sensors 1840 and receive data regarding the at

least one wellbore parameter from the MEMS sensors 1840. In an embodiment, the unit 1810 may also comprise at least one acoustic sensor 1852, which is configured to input ultrasonic waves 1854 into the wellbore servicing fluid 1830 and/or into the oil or gas formation 14 proximate to the wellbore 18 and receive ultrasonic waves reflected by the wellbore servicing fluid 1830 and/or the oil or gas formation 14. In an embodiment, the at least one acoustic sensor 1852 may transmit and receive ultrasonic waves using a pulse-echo method or pitch-catch method of ultrasonic sampling/testing. A discussion of the pulse-echo and pitch-catch methods of ultrasonic sampling/testing may be found in the NASA preferred reliability practice no. PT-TE-1422, "Ultrasonic Testing of Aerospace Materials," In alternative embodiments, ultrasonic waves and/or acoustic sensors may be provided via the unit 1810 in accordance with one or more embodiments disclosed in U.S. Pat. Nos. 5,995,447; 6,041,861; or 6,712,138, each of which is incorporated herein in its entirety.

[00139] In an embodiment, the at least one acoustic sensor 1852 may be able to detect a presence and a position in the wellbore 18 of a liquid phase and/or a solid phase of the wellbore servicing fluid 1830. In addition, the at least one acoustic sensor 1852 may be able to detect a presence of cracks and/or voids and/or inclusions in a solid phase of the wellbore servicing fluid 1830, e.g., in a partially cured cement slurry or a fully cured cement sheath. In a further embodiment, the acoustic sensor 1852 may be able to determine a porosity of the oil or gas formation 14. In a further embodiment, the acoustic sensor 1852 may be configured to detect a presence of the MEMS sensors 1840 in the wellbore servicing fluid 1830. In particular, the acoustic sensor may scan for the physical presence of MEMS sensors proximate thereto, and may thereby be used to verify data derived from the MEMS sensors. For example, where acoustic sensor 1852 does not detect the presence of MEMS sensors, such lack of detection may provide a further indication that a wellbore servicing fluid has not yet arrived at that location (for example, has not entered the annulus). Likewise, where acoustic sensor 1852 does detect the presence of MEMS sensors, such presence may be further verified by interrogation on the MEMS sensors. Furthermore, a failed attempt to interrogate the MEMS sensors where acoustic sensor 1852 indicates their presence may be used to trouble-shoot or otherwise indicate that a problem may exist with the MEMS sensor system (e.g., a fix data interrogation unit may be faulty thereby requiring

repair and/or deployment of a mobile unit into the wellbore). In various embodiments, the acoustic sensor 1852 may perform any combination of the listed functions.

5 [00140] In an embodiment, the acoustic sensor 1852 may be a piezoelectric-type sensor comprising at least one piezoelectric transducer for inputting ultrasonic waves into the wellbore servicing fluid 1830. A discussion of acoustic sensors comprising piezoelectric composite transducers may be found in U.S. Pat. No. 7,036,363, which is hereby incorporated by reference herein in its entirety.

10 [00141] In an embodiment, the regional communication unit 1810 may further comprise an acoustic transceiver 1856. The acoustic transceiver 1856 may comprise an acoustic receiver 1858, an acoustic transmitter 1860 and a microprocessor 1862. The microprocessor 1862 may be configured to receive MEMS sensor data from the interrogation unit 1850 and/or acoustic sensor data from the at least one acoustic sensor 1852 and convert the sensor data into a form that may be transmitted by the acoustic transmitter 1860.

15 [00142] In an embodiment, the acoustic transmitter 1860 may be configured to transmit the sensor data from the MEMS sensors 1840 and/or the acoustic sensor 1852 to an interrogation/communication unit situated uphole (e.g., the next unit directly uphole) from the unit 1810 shown in FIG. 18. The acoustic transmitter 1860 may comprise a plurality of piezoelectric plate elements in one or more plate assemblies configured to input
20 ultrasonic waves into the casing 20 and/or the wellbore servicing fluid 1830 in the form of acoustic signals (for example to provide acoustic telemetry communications/signals as described in various embodiments herein). Examples of acoustic transmitters comprising piezoelectric plate elements are given in U.S. Patent Application Publication No. 2009/0022011, which is hereby incorporated by reference herein in its entirety.

25 [00143] In an embodiment, the acoustic receiver 1858 may be configured to receive sensor data in the form of acoustic signals from one or more acoustic transmitters disposed in one or more interrogation/communication units situated uphole and/or downhole from the unit 1810 shown in FIG. 18. In addition, the acoustic receiver 1858 may be configured to transmit the sensor data to the microprocessor 1862. In embodiments, a microprocessor or
30 digital signal processor may be used to process sensor data, interrogate sensors and/or interrogation/communication units and communicate with devices situated at an exterior of a wellbore. For example, the microprocessor 1862 may then route/convey/retransmit the

received data (and additionally/optionally convert or process the received data) to the interrogation/communication unit situated directly uphole and/or downhole from the unit 1810 shown in FIG. 18. Alternatively, the received sensor data may be passed along to the next interrogation/communication unit without undergoing any transformation or further processing by microprocessor 1862. In this manner, sensor data acquired by interrogators 1850 and acoustic sensors 1852 situated in units 1810 disposed along at least a portion of the length of the casing 20 may be transmitted up or down the wellbore 18 to the processing unit 1820, which is configured to process the sensor data.

[00144] As is apparent from the discussion above, in many example systems, a plurality of communication assemblies (or communication units) will be disposed in longitudinally-spaced relation to each other along the casing 20, at least over a region of interest relative to either the sealing operation or to other downhole conditions.

[00145] As previously described regarding at least FIG. 1, a location, in particular a top location, of the sealant (i.e., generically referred to as "top of cement," or "TOC") can be determined by finding a location on casing string 20 where below it, primarily only tags associated with the sealant are identified, while above the location, only tags associated with other fluids, for example spacer fluid or drilling mud, are identified. It will be understood there may be some mixing due to irregularities in the formation sidewalls that will trap some of the tags and possibly their associated fluids from the spacer and mud pumped through annulus 26. Therefore, some tags associated with one type of fluid may become mixed with a different type of fluid than that indicated by the tag type.

[00146] Each communication assembly will preferably include an azimuthal indicator, for example a compass, to determine the orientation of the communication assembly once it is disposed within the borehole. With a known orientation of the communication assembly, the orientation of each rib and/or RFID sensor assembly will be known and therefore the quadrant or other azimuthally offset region being investigated will similarly be known. The depth of each casing assembly can be known, for example through a record of the location of each communication assembly as it is associated with the casing string 20 as the string is placed in the wellbore, providing a measure of depth as to the surface.

[00147] In different examples, TOC measurement can be done after the pumping of the sealant is completed or the measurement can be a dynamic measurement of the TOC while the sealant is moving up annulus 26. The other measurements described herein

facilitate measurements not only of the TOC, but also of the distribution of the cement or other sealant around the casing over the region of the casing string that includes associated communication assemblies. Regions where a minimal number of tags of the type entrained within the sealant are located indicate a region where, for some reason, sealant has been

5 blocked from reaching the region, or has reached the region in a relatively limited volume.

Identifying both the depth and orientation where this occurs facilitates remediation efforts

[00148] Each communication assembly 1400 can report information associated with the sensed tags to a surface system, for example surface system 630, using communication methods described above regarding FIG. 5-7. In some examples, this may be as basic as a

10 number of tags sensed within a given time interval, grouped or formatted in a manner to

indicate the azimuthal orientation of the sensing. Sometimes, this will include a similar

number of tags of each of a plurality of frequencies sensed within the time interval, and

grouped or formatted to indicate the azimuthal orientation. In other example systems, RFID

tags may be used which include tag IDs, facilitating identification of which individual tags

15 have been sensed. As noted above, the information associated with the sensed tags may include MEMS sensor data.

[00149] The novel techniques described above to determine whether sealant (or another fluid in the borehole) is observed in a volume throughout the surrounding annulus consistent with a successful cementing (i.e. sealing). This operation can be achieved

20 through use of relatively simple RFID tags. As discussed earlier, similar relatively simple

RFID tags responsive to a different frequency may be dispersed into other fluids, so that the progress of multiple fluids in the annulus can be observed.

[00150] While these measurements with relatively simple RFID tags are extremely useful, it must be understood that similar techniques are applicable to perform more

25 sophisticated measurements. As described earlier, more sophisticated RFID tags having

associated MEMS sensors of various types may be placed within the well servicing fluids

(see paragraph [0083]). These MEMS sensor tags may include sensors for detecting

temperature or any of a variety of fluid properties, etc. These additional properties can be important to fully evaluating the quality of the sealing operation, particularly over time.

30 **[00151]** For example, monitoring temperature in the annulus can identify regions

where the sealant is curing either improperly or inconsistently relative to other areas in the

annulus. The ability to identify azimuthal regions where the temperature is inconsistent

either with other regions or with expectations can be useful in identifying defects such as fluid incursions. Such temperature sensing MEMS RFID tags may in some cases be active (having a contained power source) or may be passive and energized by the interrogation signal.

5 [00152] Sensed fluid properties may also be of significant use in evaluating the sealing operation. For example, a change in pH in a region of the annulus may also indicate a fluid incursion potentially adversely affecting the sealing operation. As with other measurements, the ability to identify an azimuthal orientation of the sensed parameter provides valuable information facilitating further analysis and/or remediation within the well. Again, in various embodiments these tags may be either active or passive.

Temperature Monitoring Through the Communication Assemblies

[00153] As noted above, in some example systems, temperature sensing MEMS sensor RFID tags may be used to monitor temperature within the annulus to evaluate curing of the sealant. In some situations, temperature variations might indicate fluid incursion and/or low barrier quality. As an alternative to tag-based temperature monitoring, in some example systems, temperature sensors can be mounted on or associated with the communication assemblies, rather than the RFID tags. In some examples, these sensors may be mounted directly on the surface of the communication assembly. However, in some applications, it may be desirable to extend the sensors away from the communication assembly and casing, both to avoid temperature effects from those members, and to more directly monitor temperatures in the annulus.

[00154] To achieve this result, in some examples, one or more flexible fingers supporting temperature sensors can be anchored on the communication assembly with the temperature sensors electrically coupled to the circuitry therein. The flexible fingers will typically be oriented to extend out into the annulus 26, and to extend in an uphole direction, so that as the casing string is lowered into the borehole, the fingers would be pointed back up toward the surface so they would not be caught on the formation during the run-in, but would instead drag the tips down the formation wall. When the sealant is pumped up the well from the bottom, again the fingers would be pointed downstream (i.e. uphole) with respect to the flowing sealant and would maintain their orientation in the annulus 26. The temperature sensors and the wires leading back to the casing collar can be

placed on the side of the fingers oriented toward the casing collar, thus protecting the sensors and wiring from the formation wall and the flowing sealant. With the sensors distributed along the fingers across the annulus 26, thermal measurement of the sealant may be improved. In such examples, the temperature information can be communicated to a receiving unit, such as a surface unit 630, along with the other sensed information from the communication assembly.

Zone Fault Detection

[00155] Turning to Fig. 16, the figure schematically depicts an idealized functional representation (for ease of explanation) 1600 of the functionality resulting from a plurality of sensors arranged to provide four distinct azimuthally offset regions 1605A-D of sensor investigation surrounding a casing 1602 in a borehole. As noted above, various RFID sensor assemblies may be configured as part of a communication assembly associated with a casing string to provide an azimuthally-oriented region of investigation relative to the casing string.

[00156] In this idealized representation, each of azimuthally offset regions (AORs) 1605A-D encompasses a respective quadrant of a circumferential region of investigation 1603 surrounding casing string 1602. As will be apparent to persons skilled in the art, in practice the azimuthal regions will not be so precisely defined, and sensitivity of some sensors may not be consistent across the entire scope of an azimuthal region, and in some cases some sensors need not be sensitive across the full extent of an azimuthal region. As one example of many possible variations, RFID sensors may be configured to interrogate tags generally across an azimuthal quadrant of the well annulus; but only a single measurement of a different type, for example temperature, will be needed within each azimuthal region.

[00157] In some example systems, the circumferential region of investigation 1603 may extend only to a radially spaced portion of the annulus surrounding casing string 1602, while in other example systems, the circumferential region of investigation 1603 may extend across the full radial dimension of the annulus and even, in some systems, into the surrounding formations.

[00158] As is apparent from the above discussion, measurements within each azimuthal region will provide a measure of conditions surround the casing. Similar benefits will be obtained even if each azimuthal region is only a portion (i.e., a "slice") within each

quadrant. Additionally, sensors may be configured (and/or have their outputs grouped together) provide any number and orientation of desired azimuthal regions.

[00159] Turning to Fig. 17, the figure depicts a flow chart of an example embodiment of a method 1700 for evaluating faults in placing of fluids or other materials in a wellbore. At
5 step 1702, a plurality of RFID tags are placed into a wellbore servicing fluid. As noted earlier, the wellbore servicing fluid may include drilling mud, cement, and/or other fluid(s) in various embodiments. For the present example, the method is described as a sealing (such as cementing) operation, using the fluids typical for such operations. In some examples, the RFID tags placed in the wellbore fluid are passive RFID tags as described earlier herein, and
10 in some embodiments at least some portion of the tags will have associated MEMS sensors, also as described earlier herein. Alternatively, other RFID tags, as described earlier herein, such as active RFID tags, may be used.

[00160] In some embodiments, multiple fluids (e.g., drilling fluid (or another “cleaning” fluid), followed by cement) containing RFID tags of distinct configurations will be
15 placed into the respective servicing fluids to enable monitoring of the different fluids, and in the case of materials remaining in the well annulus (such as cement or another sealant), also for later evaluation of the material. For purposes of the present example, the discussion will focus on the ultimate objective of monitoring the cement.

[00161] At step 1704, the wellbore fluid containing the RFID tags is pumped down
20 through the casing, and then up through the surrounding annulus. This step is performed using a surface pump (or pumps), through techniques known to those skilled in the art.

[00162] At step 1706, sensors arranged to be responsive to events in a respective region of the plurality of azimuthally offset regions (e.g., such as AORs 1605A-D), are monitored to obtain data associated with the RFID tags that have been placed into the
25 wellbore fluid(s). In most examples, this will be performed at a plurality of depths within the well, through azimuthally oriented RFID sensors at each depth. The recited monitoring at each of the various depths can be initiated in a number of different ways. As a first example, the monitoring can begin at all depths once the cement is initially pumped into the casing, or may be started at a desired time thereafter. In other examples, the monitoring
30 may be initially performed at the lowermost depths, for one example the lowermost three depths at which sensors are located, and only later initiated at higher depths in the borehole. In many envisioned examples, the RFID sensors will be configured to start

monitoring after passage of a predetermined time interval from the time the sensors are placed into the wellbore with the casing.

[00163] Once monitoring begins and the fluid and contained RFID tags reach the depth of the lowest RFID sensors, the RFID sensors will obtain data associated with the tags.

5 In some examples this obtaining of data includes merely recording the detection of some number of tags within an azimuthal region within a given time frame. In other examples, the obtaining of data will include monitoring specific tag information, such as, for example, recording the tag ID of an individual RFID tag detected within an azimuthal region; or in other examples, recording data from the tag, such as data from a MEMS sensor in the tag.

10 **[00164]** In some examples this monitoring will be performed in response to a command received from a surface computing system, while in other examples, the monitoring will be performed either based on instructions received from a controller within the borehole, or by pre-programmed instructions stored in a sensor or controller assembly, or by some combination thereof. In many examples, monitoring (i.e., detection) of RFID tags may be performed periodically (e.g., for selected time periods at a selected intervals).

15 **[00165]** Detection of the RFID tags associated with the cement in at least one azimuthal region of the annulus at a first depth provides an indicator that the top of cement (TOC) has reached the depth of the RFID sensor detecting the tag. In many operations, the cement will reach all azimuthal regions at a given well depth essentially simultaneously. In other operations, such as where a well is relatively highly deviated, the cement may naturally reach one azimuthal zone in advance of reaching others. However, in some cases the failure of the cement to reach all azimuthal regions at a given depth within some time interval will be an indication of a blockage of the annulus. Such a blockage will often result in a defect in the cement sheath and the isolation provided thereby.

25 **[00166]** Accordingly, after RFID tags have been detected in one azimuthal region at a given depth, then a determination must be made, at step 1708, as to whether the tags have been detected in each additional azimuthal region at such depth. If not, then a determination will be made, at 1710, as to whether the elapsed time since the first tag detection is greater than a threshold. The threshold may be established, for example, as a time period consistent with a "normal" cementing operation in a well, preferably one having
30 a configuration generally comparable to the well being cemented. If that threshold period of time has not been reached, then the monitoring will continue, as through step 1706.

However, if the threshold period of time since the first detection has passed, then some notification will be provided, for example, to the well operator, as shown at step 1716.

5 [00167] In the event that RFID tags are detected in each azimuthal region at the first depth, then in the depicted example method, a qualitative measurement will be made. At step 1712, comparisons will be made of the number of tags detected in each azimuthal region. The measurements used for these comparisons may be measurements within a selected relatively short period of time, for example from a few seconds (or less), to over several minutes or potentially even longer periods of time. In some embodiments, the numbers of RFID tags in each azimuthal region may be detected during non-contiguous
10 periods. For example, the first number of tags might be detected as a total number of RFID tags seen in a first period of a selected duration plus an additional number of RFID tags detected in a later period of a selected duration. As will be apparent to persons skilled in the art having the benefit of this disclosure, variations for obtaining data over multiple time periods can be envisioned for use in methods described herein.

15 [00168] Additionally, the sensing of RFID tags may vary as a function of depth within the well. For example, sensors at relatively lower depths will have cement flowing past them for a greater length of time than will sensors at relatively higher depths. As a result, the measurements will be more dynamic for these lower depths during the relatively earlier stages of pumping, and might desirably be limited in some cases, for example either to
20 measurements obtained relatively late in the pumping cycle or to measurements over a different periods of time than those taken at relatively higher depths.

[00169] Where RFID tag detection within an azimuthal region is performed through use of multiple RFID sensor assemblies, in some examples detected RFID tag counts from each of the RFID sensor assemblies interrogating in that azimuthal zone may be totaled to
25 yield a single number of RFID tags detected in that azimuthal region. In other examples, tags from each RFID sensor assembly may be counted alone, and later grouped to a given azimuthal region through later processing. In embodiments in which RFID tags have unique identifiers, duplicate tags that are detected by two or more RFID sensor assemblies may be subtracted from a total number of tags detected so that duplicative counting does not
30 occur. Additionally, in some systems in which such RFID tags with unique identifiers are used, the detected tag IDs may be tracked to assure that a tag detected in a first depth has

not moved to, or otherwise been counted at, a different depth, leading to a measurement error.

[00170] At step 1714, the compared numbers of RFID tags detected in each azimuthal region will be evaluated to provide a measure of whether the cement is present in a sufficient volume to provide adequate isolation. In some example methods, this comparison of the numbers of detected RFID tags in an azimuthal region (or in some portion of a region), may be made relative to corresponding measurements in another azimuthal region, to provide a differential measurement (e.g., in some examples, a ratio) of the detected tags in each of the separate azimuthal regions. As will be apparent to persons skilled in the art having the benefit of this disclosure, an ideal case would be presented by comparisons indicative of equal numbers of tags (and therefore typically of cement) at each azimuthal region. In other example methods, the numbers of detected RFID tags may be compared instead (or in addition), to external reference values. Such external reference values can be determined, for example, empirically from other operations. In yet another example method, the numbers of detected tags in each azimuthal region in a given depth may be also compared, or further compared, to detected RFID tags in selected azimuthal regions at one or more different depths in the well.

[00171] Whatever measurements and evaluations of the detected tags are relied upon, in most methodologies there will be some reference threshold identifying whether there is, or may be, some possible defect in the cement distribution. A determination is made of the detected RFID tags, and/or the differential measurements of the tags, in the azimuthal regions relative to that reference threshold (or thresholds), and if there is an indication of potentially inadequate isolation (or some other defect) an alert will be provided to the operator, as discussed above relative to step 1716.

[00172] As noted at step 1718, the above monitoring and evaluation steps 1706 -1714 will be repeated at each sensor depth location of interest. As noted earlier, these monitoring and evaluating steps can all occur simultaneously, or may be performed in some sequential manner, which in some examples may be initiated in response to prior monitoring and/or evaluation. For example, where the start time of monitoring at each depth is controllable, monitoring at some relatively higher depths can be initiated only after detection of a servicing fluid (possibly sealant) at one or more lower depths.

[00173] Although the monitoring and evaluation has been discussed to this point only in reference to detection of RFID tags, other monitoring may optionally be performed on an azimuthal basis, and evaluated to identify faults other than placement of cement. As one of many possible examples of such options, after TOC is detected at any given depth, it may be
5 advantageous to monitor temperatures in azimuthally offset regions at that depth, as indicated at step 1720. Such temperature measurements are of significant value since the curing of cement is an exothermic reaction and the curve of temperature variations during the curing process can be used to evaluate the curing and any anomalies thereof. Additionally, azimuthal regions reflecting a relatively lower temperature during curing,
10 either compared to other measurements at the same depth, or to measurements at other depths, may be indicative of fluid incursion from the formation.

[00174] Different methods may be used to perform this monitoring of temperatures. In some example systems, temperature sensors supported by a communication assembly associated with the casing (as described in the preceding section) will be used to make
15 temperature measurements of the cement. In other examples, RFID tags having associated MEMS temperature sensors as described earlier herein will be interrogated to provide temperature measurements in the cement.

[00175] Once temperatures have been monitored at each depth over one or more selected time periods, those temperatures will be evaluated to determine if either the
20 measured temperatures or the temperature differentials between azimuthal regions are within acceptable boundary conditions (values, ratios, etc.), as indicated at step 1722. In the event that the temperatures or differentials are outside of the acceptable boundary conditions, then as indicated at step 1726, the operator will be alerted.

[00176] After the passing of some period of time after pumping of cement is
25 terminated, continued monitoring of RFID tags will be of limited value, as the cement will begin to cure and the placement of tags should achieve a steady state. In contrast, monitoring of the temperature may have value for an extended period after pumping of cement is terminated. The curing process may last for substantial periods of time, from several days to several weeks. Even after the curing process concludes, temperature
30 variations may be indicative of other defects. Accordingly, in the depicted example method, the temperature monitoring will be continued at selected intervals for either a preselected

length of time, or for a time period determined in response to either previously obtained measurements or limitations of the hardware system used.

[00177] As another form of optional monitoring that may be used instead of or in addition to temperature, monitoring properties of fluids in the annulus may be useful to identify fluid incursions into the cement sheath. As noted earlier, various fluid properties may be sensed by RFID tags having appropriate MEMS sensors. Alternatively, appropriate sensors may be placed in the annulus, secured either to the exterior of the casing or to a communication assembly associated therewith. Such fluid parameters may be monitored in essentially the same manner as described above relative to the monitoring of temperature in the annulus.

[00178] Some or all of the evaluation steps of method 1700 (such as steps 1708, 1710, 1712, 1714, 1722) may be performed either downhole within a communication assembly (as described earlier in reference to Figures 15A-C) or in another location. For example, depending upon the data communication system used in the communication assemblies (or other physical devices associated with the described sensors), one communication assembly might be selected to provide processing for measurements from communication assemblies at proximate depths above and below the selected communication assembly. That configuration facilitates comparisons between measurements taken at other relatively proximate depths to be performed downhole. Alternatively, one or more of such operations can be performed by a processing system separate from the RFID sensor assemblies in a wellbore. For example, the communication assemblies or other structures associated with the wellbore RFID sensor assemblies may transmit data back to a surface computer system that then performs the evaluations.

[00179] The accompanying drawings that form a part hereof, show by way of illustration, and not of limitation, specific embodiments in which the subject matter may be practiced. The embodiments illustrated are described in sufficient detail to enable those skilled in the art to practice the teachings disclosed herein. Other embodiments may be utilized and derived therefrom, such that structural and logical substitutions and changes may be made without departing from the scope of this disclosure. This Detailed Description, therefore, is not to be taken in a limiting sense, and the scope of various embodiments is defined only by the appended claims, along with the full range of equivalents to which such claims are entitled.

[00180] Although specific embodiments have been illustrated and described herein, it should be appreciated that any arrangement configured to achieve the same purpose may be substituted for the specific embodiments shown. This disclosure is intended to cover any and all adaptations or variations of various embodiments. Combinations of the above
5 embodiments, and other embodiments not described herein, will be apparent to those of skill in the art upon reviewing the above description.

Claims

What is claimed is:

1. A method, comprising:
placing a first fluid into an annulus surrounding a casing in a borehole, the first fluid
containing a first plurality of radio frequency identification device (RFID) tags;
5 monitoring a plurality of azimuthally offset regions of the annulus for individual tags of the
first plurality of RFID tags, the plurality of azimuthally offset regions including a first
azimuthal region and a second azimuthal region at least partially offset from the first
azimuthal region;
detecting during a first time period, a number of the first plurality of RFID tags in the first
10 azimuthal region; and
detecting during a second time period, a number of the first plurality of RFID tags in the
second azimuthal region.

2. The method of claim 1, further comprising evaluating a volume of the first fluid
15 proximate the first azimuthal region based in part on the number of RFID tags of the first
plurality of RFID tags detected in the second annular region.

3. The method of claim 1, further comprising:
placing a second fluid into the annulus, the second fluid containing a second plurality of
20 RFID tags, the second plurality of RFID tags providing a different response to
interrogation than the first plurality of RFID tags;
monitoring a plurality of the azimuthally offset regions of the annulus for individual tags of
the second plurality of RFID tags;
detecting during a third time period, a number of the second plurality of RFID tags in the
25 first azimuthal region; and
detecting during a fourth time period, a number of the first plurality of RFID tags in the
second azimuthal region.

4. The method of claim 3, wherein the third and fourth time periods are the same time
30 period.

5. The method of claim 3, further comprising evaluating a volume of the first fluid proximate the first azimuthal region based in part on the number of RFID tags of the second plurality of RFID tags detected in the second annular region.
- 5
6. The method of claim 1, wherein the first and second azimuthal regions are within a specified vertical distance from one another along the casing.
7. The method of claim 6, wherein the first and second regions are at substantially the same depth location along the casing.
- 10
8. The method of claim 1, wherein the first and second time periods are different time periods.
- 15
9. The method of claim 1, wherein the first fluid comprises a sealant.
10. A method of identifying faults in a sealant in a well annulus, comprising:
placing sealant in an annulus surrounding casing in a borehole, the sealant containing a plurality of radio frequency identification device (RFID) tags;
20 monitoring for the RFID tags in a plurality of azimuthal regions of the annulus at each of a plurality of depths along the casing;
detecting the number of RFID tags present within each azimuthal region at a first depth along the casing within a respective first time period;
evaluating the detected number of RFID tags at the first depth at each azimuthal region to
25 identify if faults exist in the sealant distribution at the first depth.
11. The method of claim 10, wherein the evaluating of the detected number of RFID tags comprises comparing the number of detected tags in a first azimuthal region to the detected tags in another azimuthal region proximate the same depth along the casing.
- 30
12. The method of claim 10, further comprising:

detecting the number of RFID tags present within each azimuthal region at a second depth along the casing within a second time period; and
evaluating the detected number of RFID tags at each azimuthal region at the second depth to identify if a possible faults exists in the sealant distribution at the second depth.

5

13. The method of claim 10, wherein evaluating the detected number of tags identifies that a possible fault exists in the sealant distribution, and wherein the method further comprises providing a notification associated with the possible fault.

10 14. The method of claim 10, further comprising:
using a plurality of additional sensors configured to monitor a physical parameter of a material in the well annulus at a plurality of azimuthal regions of the annulus at each of a plurality of depths along the casing; and
evaluating the sensed parameters at each azimuthal region at a second depth to identify if a
15 possible fault exists at the second depth.

15. The method of claim 10, wherein evaluating the detected number of RFID tags at the first depth at each azimuthal region comprises making a measurement indicative of a difference between the number of RFID tags detected in a first azimuthal region and the
20 number of RFID tags detected in at least one other azimuthal region proximate the first depth.

16. The method of claim 10, wherein the number of RFID tags in an azimuthal region of the annulus provides a measure of the volume of sealant in the first azimuthal region.

25

17. The method of claim 14, wherein the additional sensors comprise MEMS sensors in the RFID tags.

18. The method of claim 14, wherein the RFID sensors are part of a communication
30 assembly coupled in the casing string, and wherein the additional sensors are also part of the communication assembly.

19. A system, comprising:
a plurality of communication assemblies arranged in spaced relation along a casing string,
each communication assembly having a plurality of RFID sensors configured to
detect RFID tags contained with a sealant in the well annulus surrounding the casing
5 in a borehole in a plurality of azimuthally offset regions of the annulus proximate the
depth of the respective communication assembly; and
a controller configured to,
cause the RFID sensors in a communication assembly to detect the number of RFID
tags in the plurality of azimuthally offset regions of the annulus proximate a
10 communication assembly during one or more time intervals, and
compare the detected number of RFID tags in a first azimuthal region of the annulus
to the detected number of RFID tags in at least one other azimuthal region of
the annulus.
- 15 20. The system of claim 19, wherein the controller comprises at least one processor.
21. The system of claim 19, wherein the controller is located within the communication
assembly.
- 20 22. The system of claim 20, wherein at least one processor is located at a surface
location.

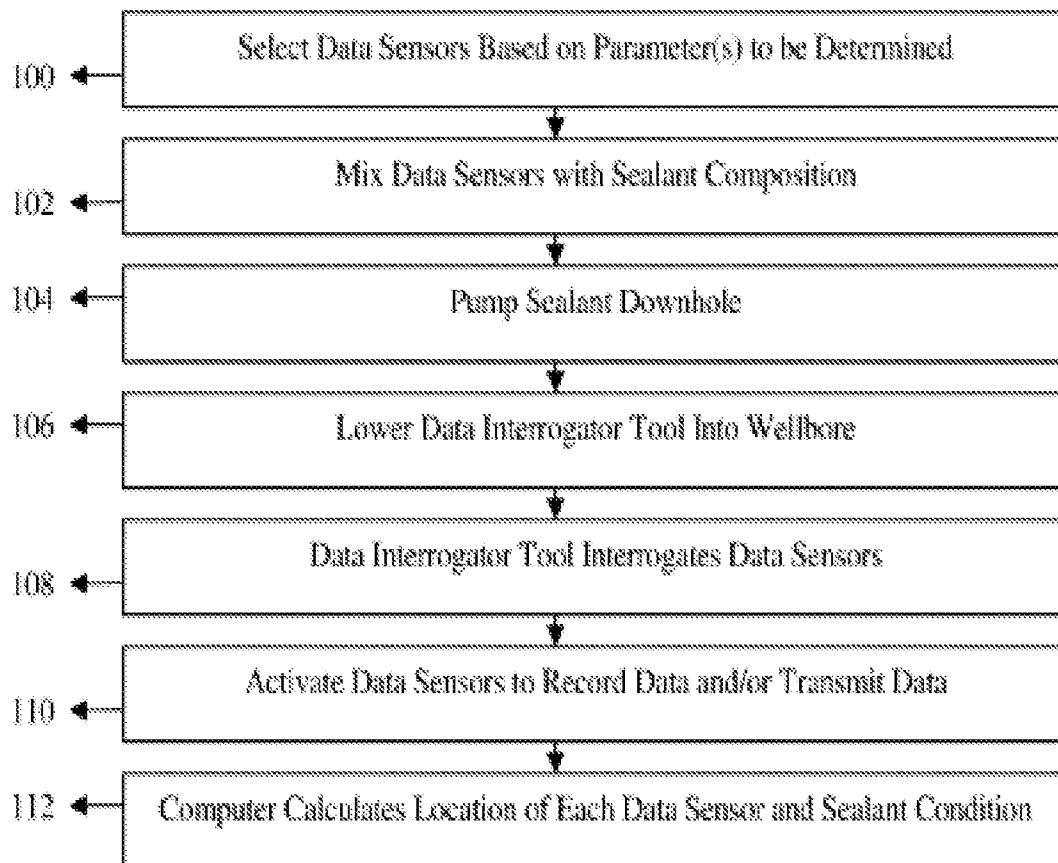

FIG. 1

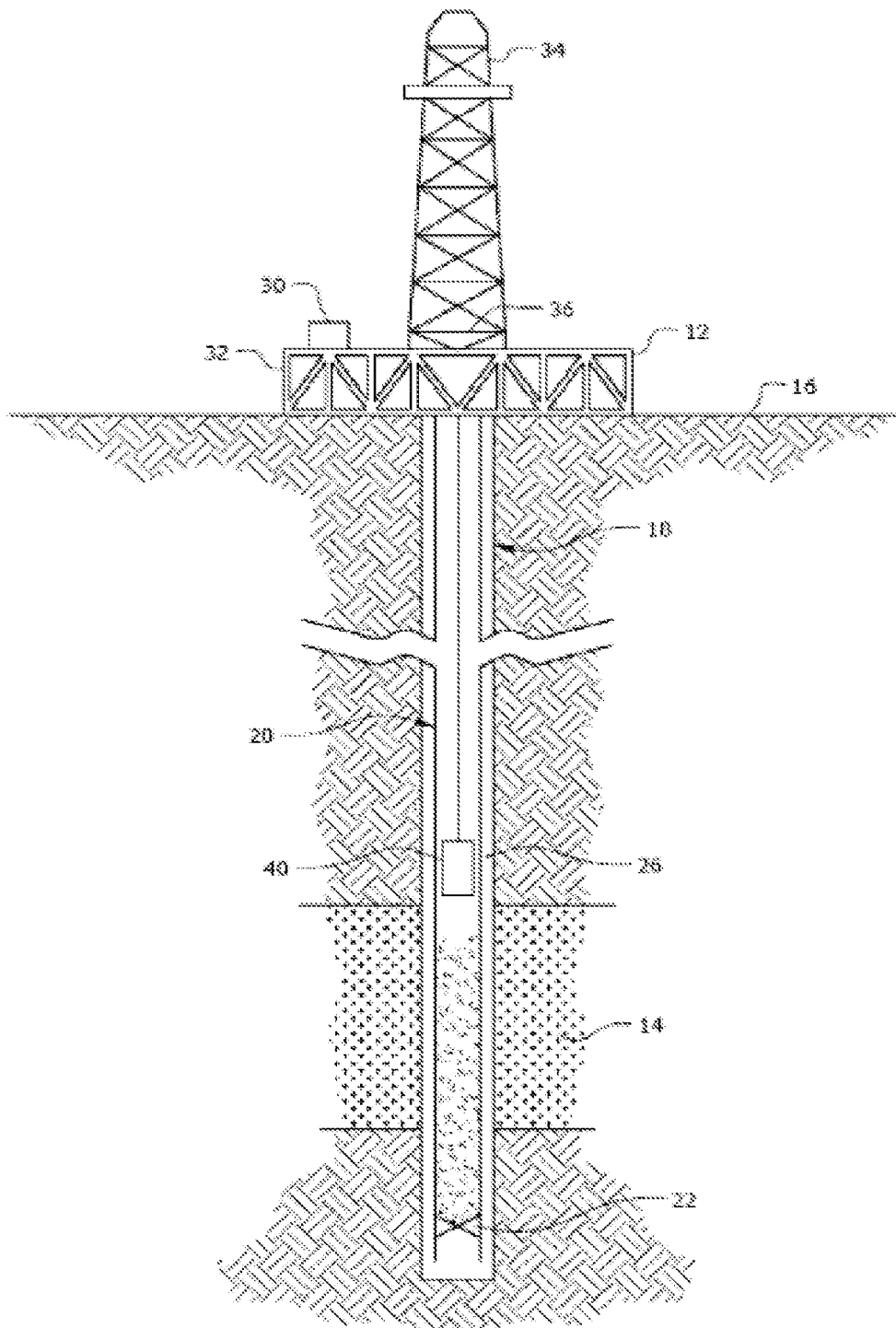

FIG. 2

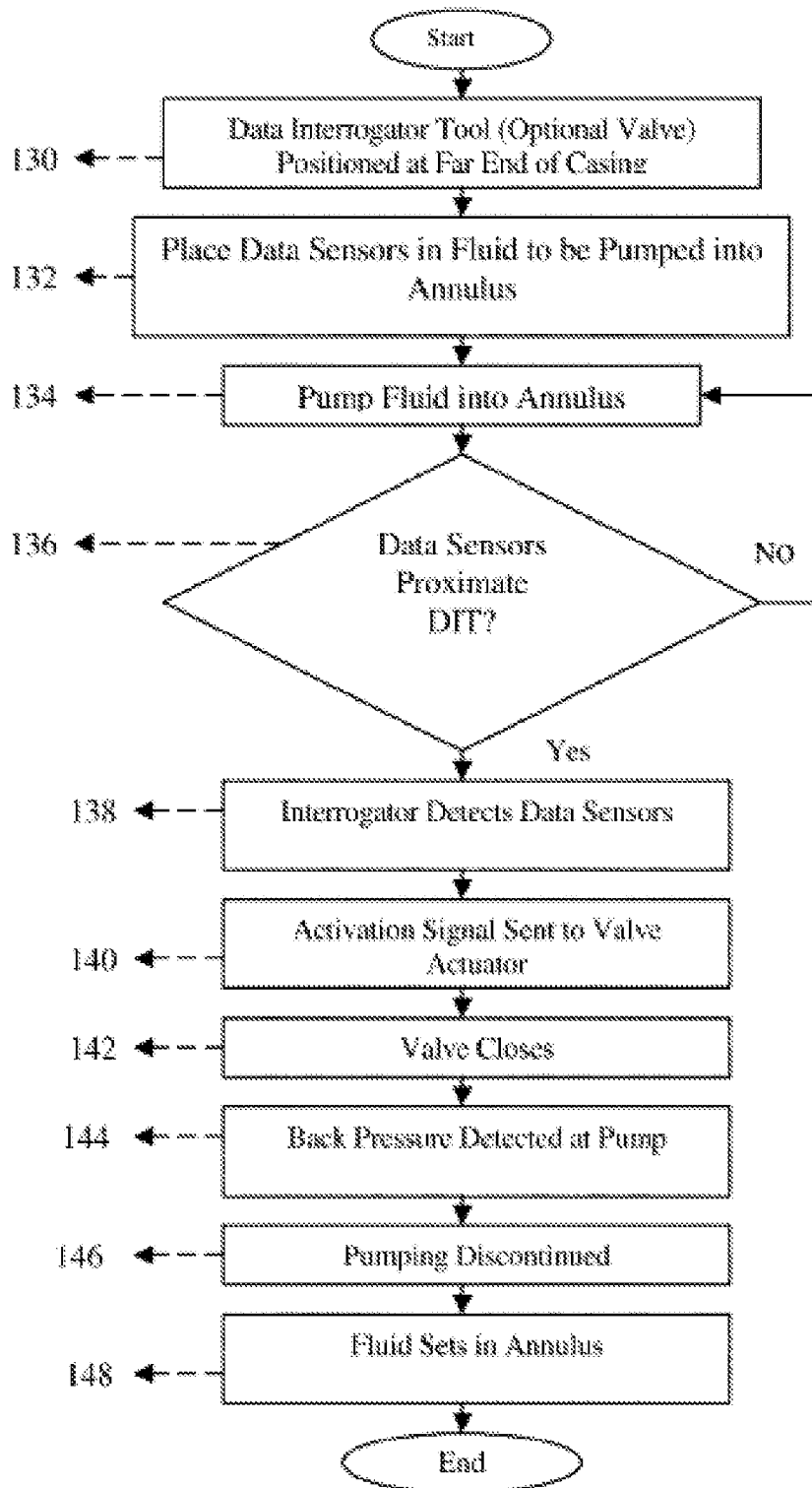

FIG. 3

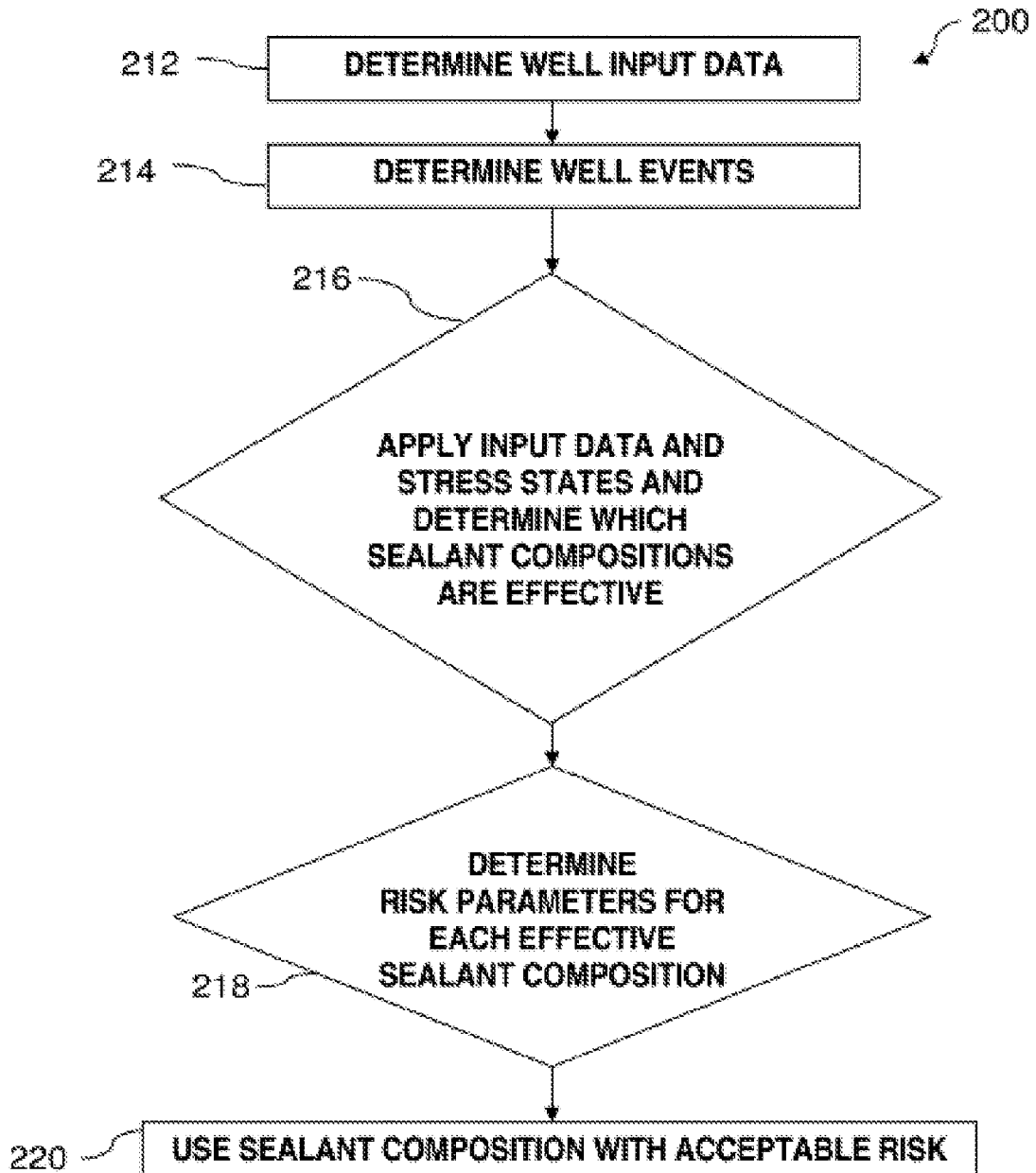

FIG. 4

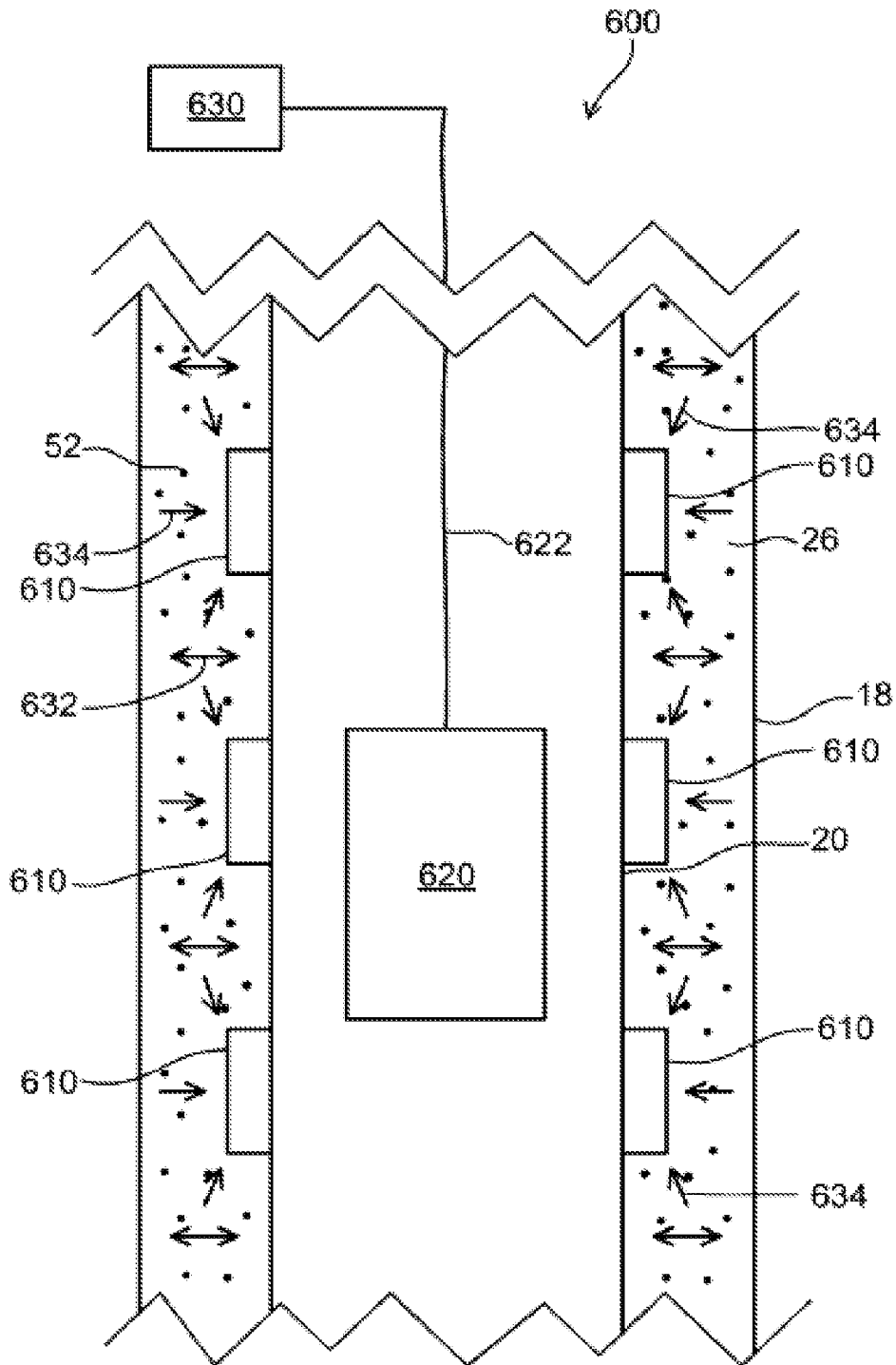

FIG. 5

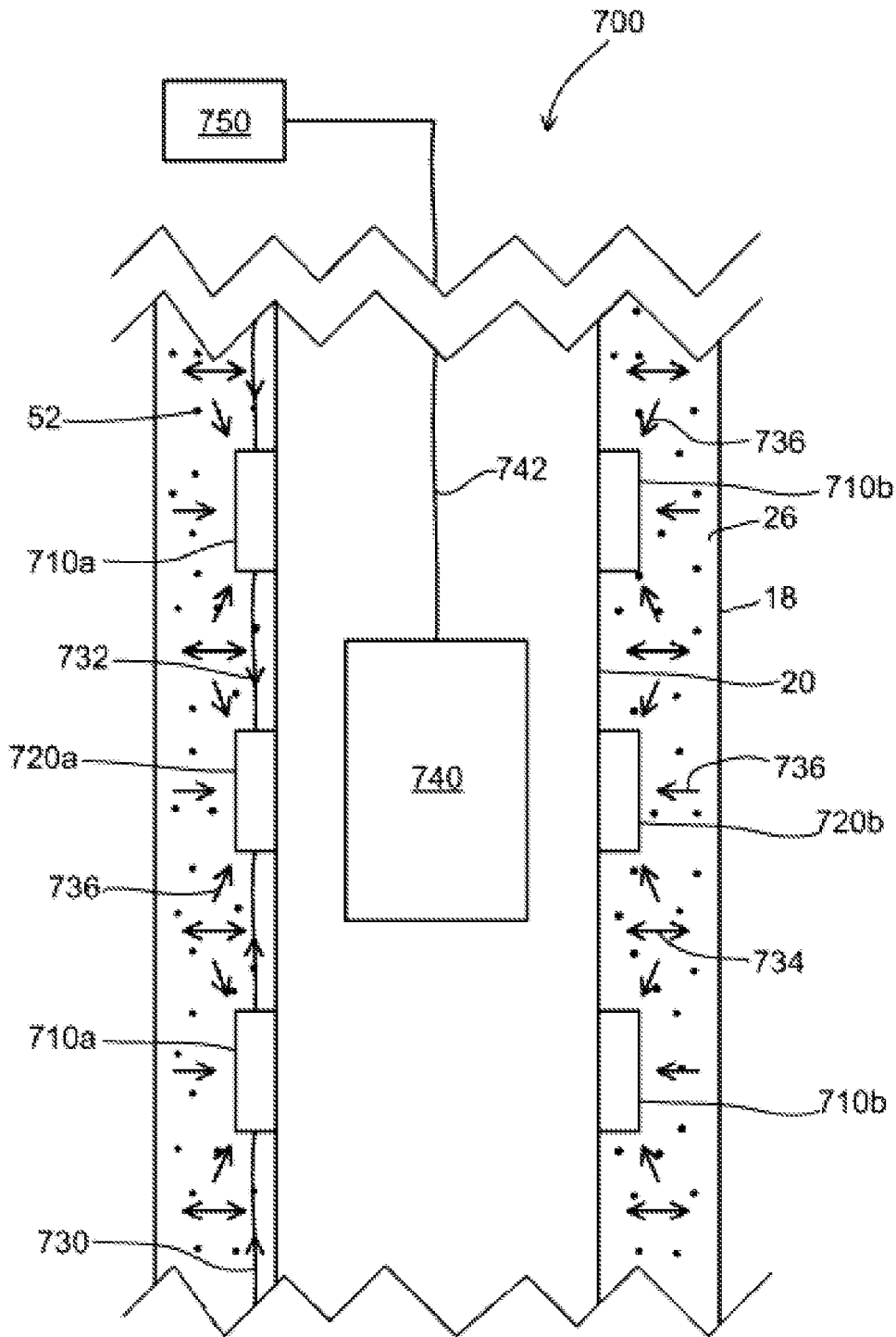

FIG. 6

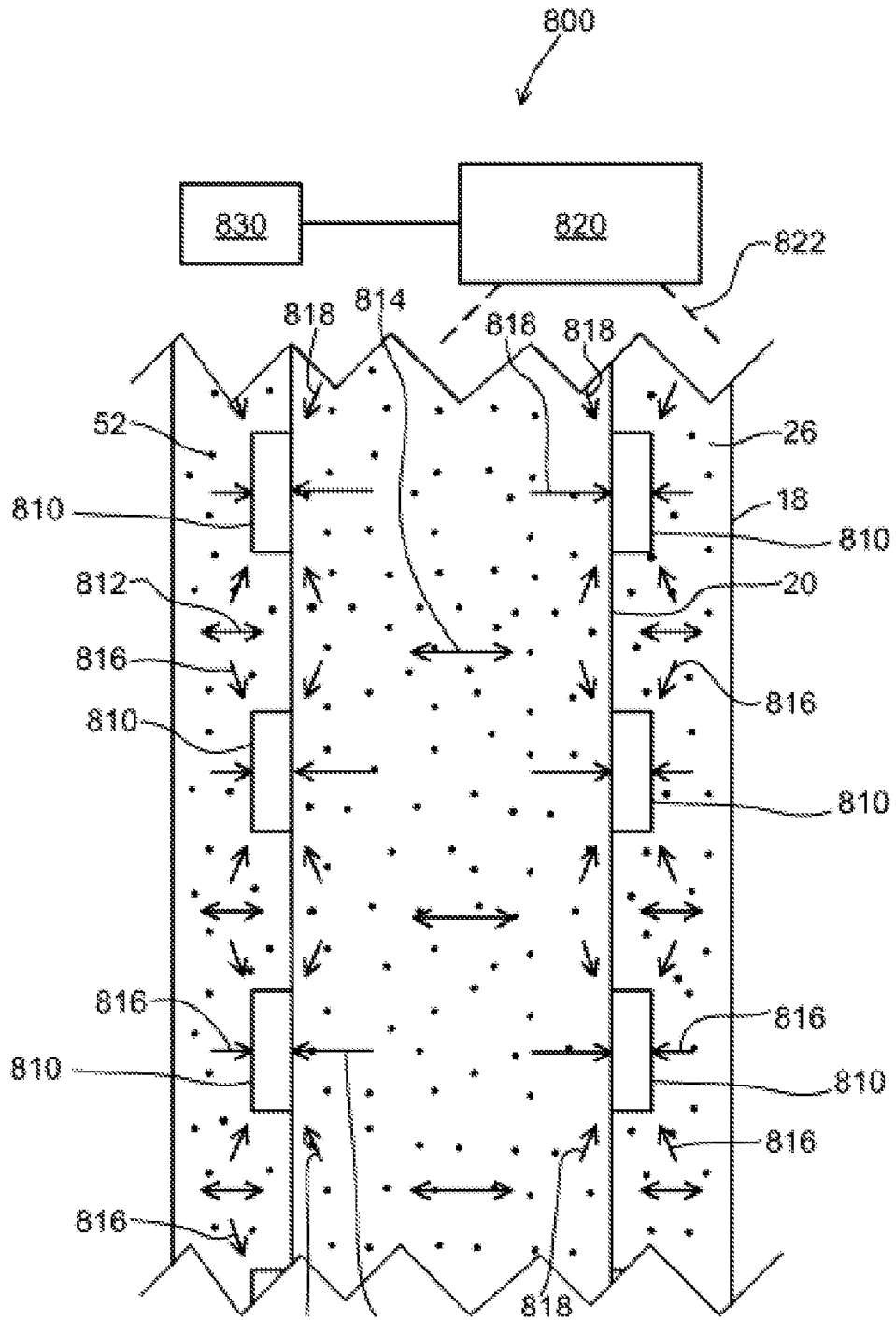

FIG. 7

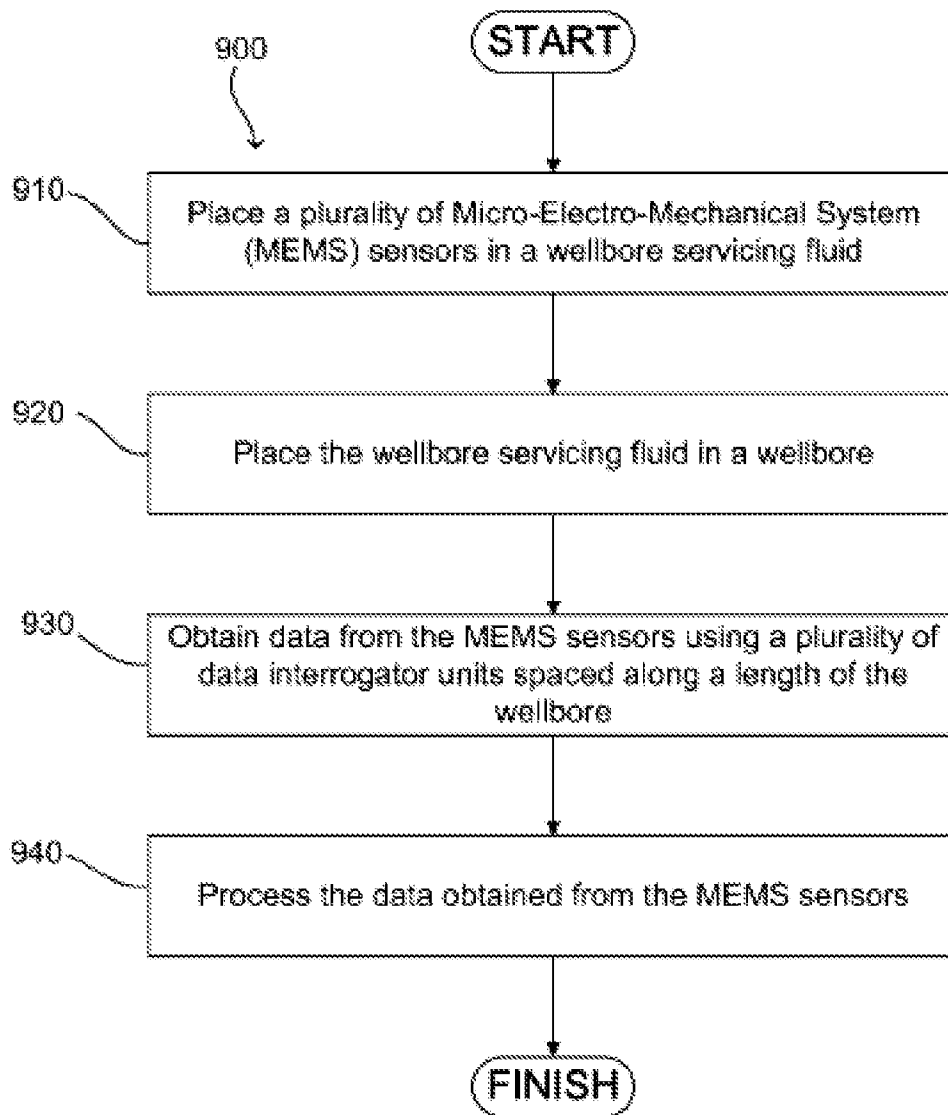

FIG. 8

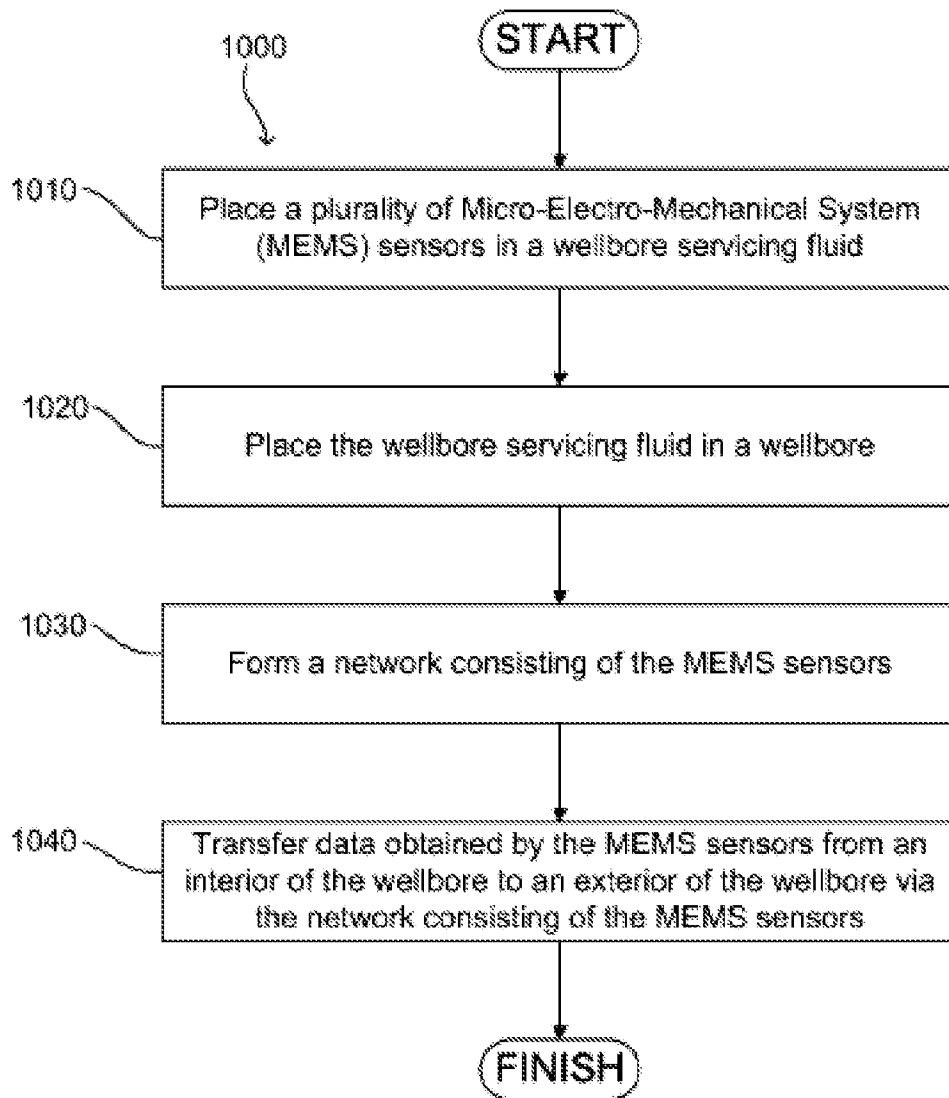

FIG. 9

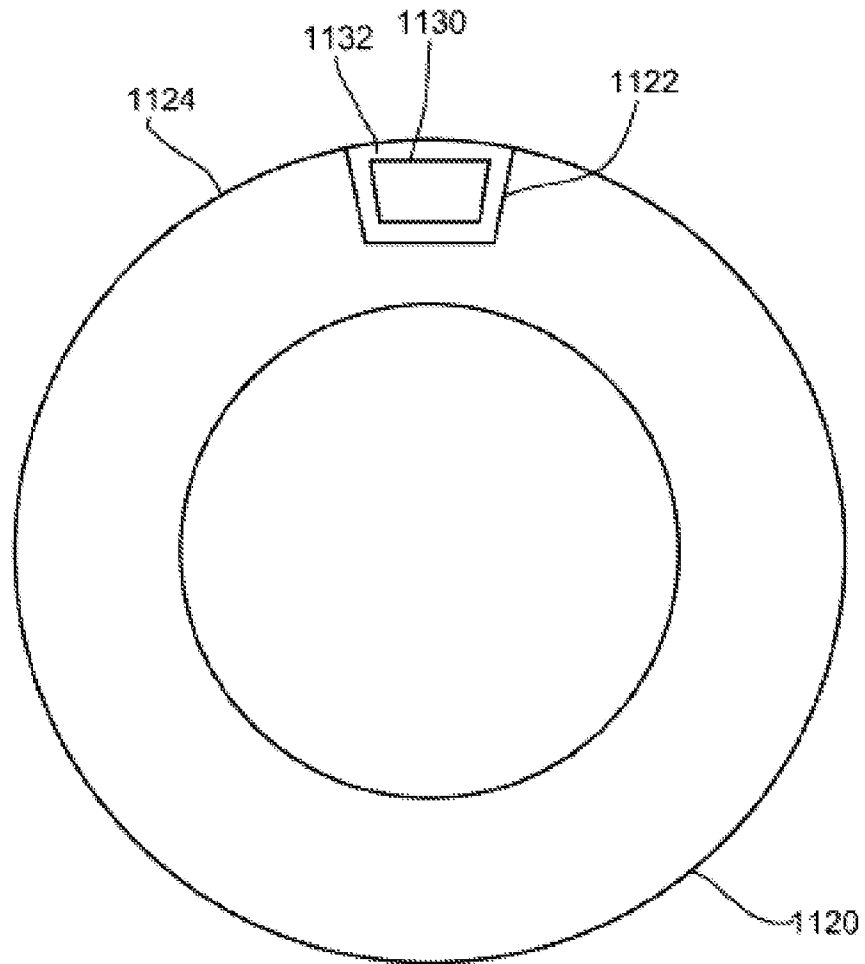

FIG. 10

11/21

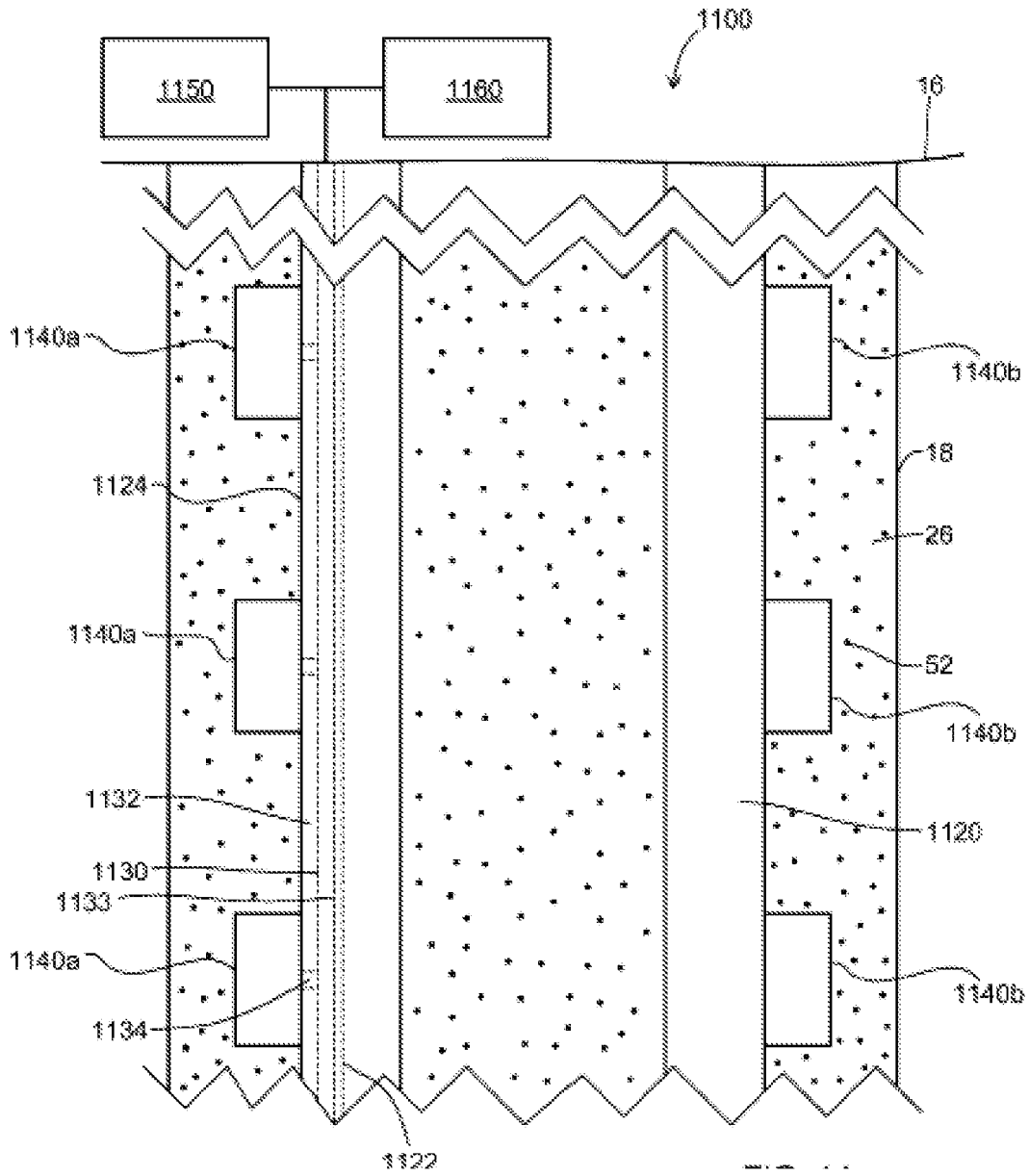

FIG.11

12/21

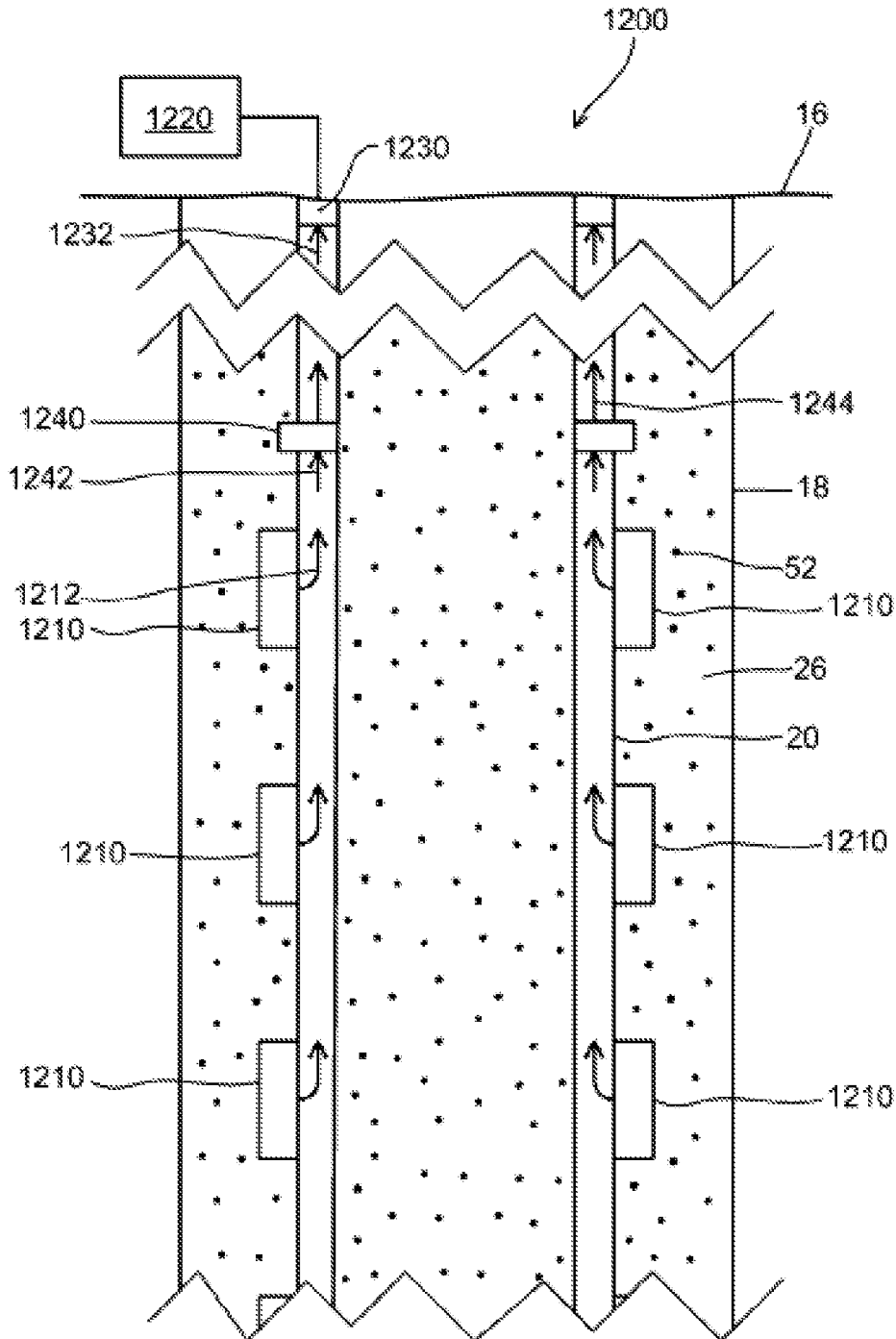

FIG. 12

13/21

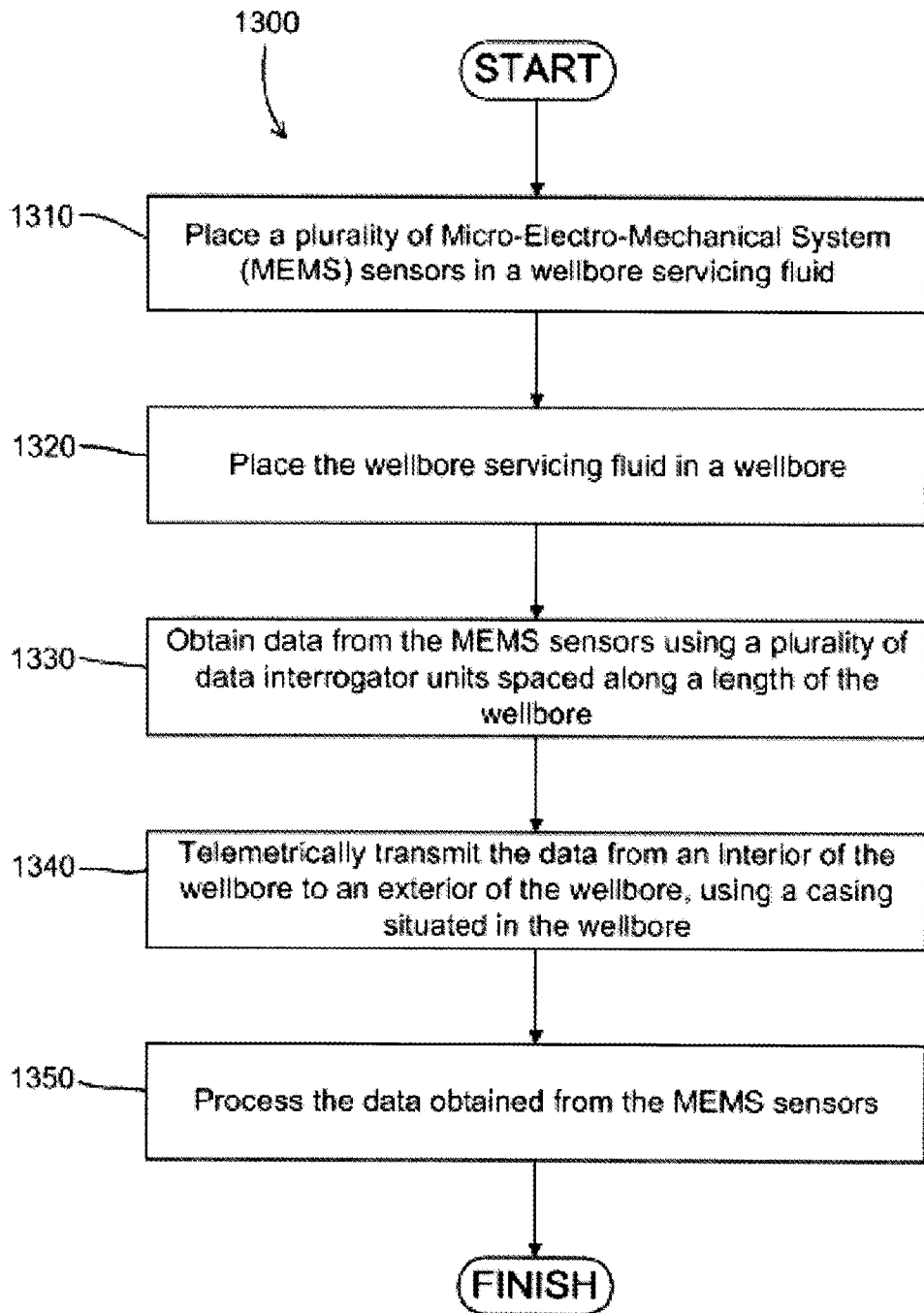

FIG. 13

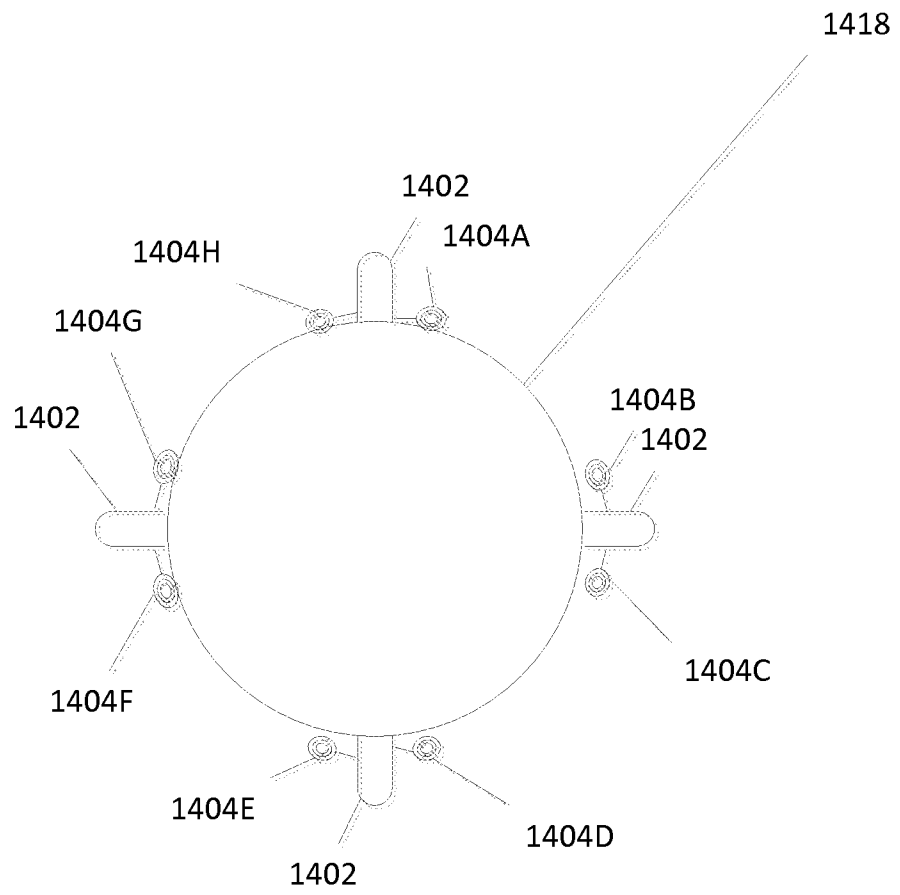

FIG. 14

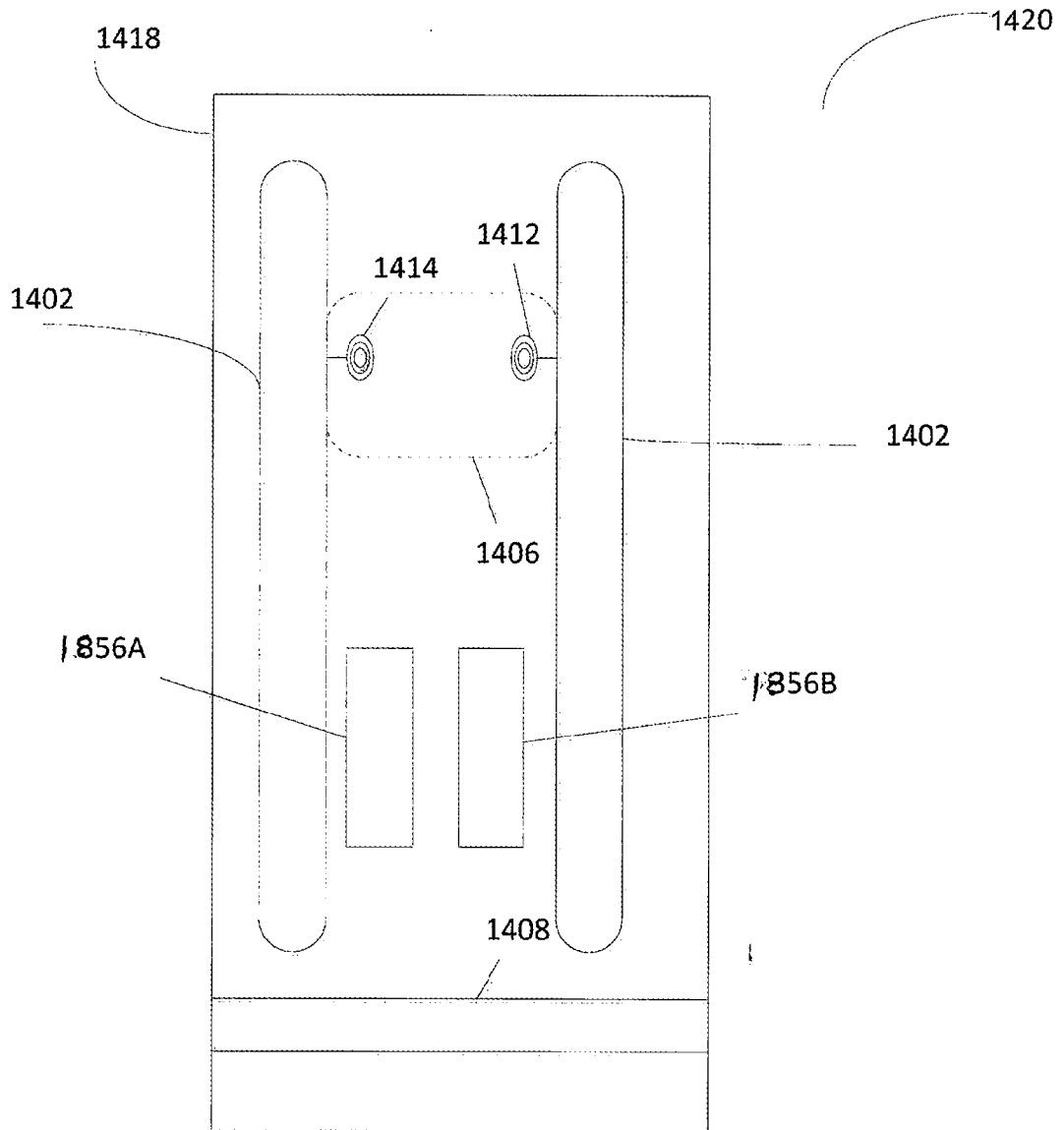

FIG. 15A

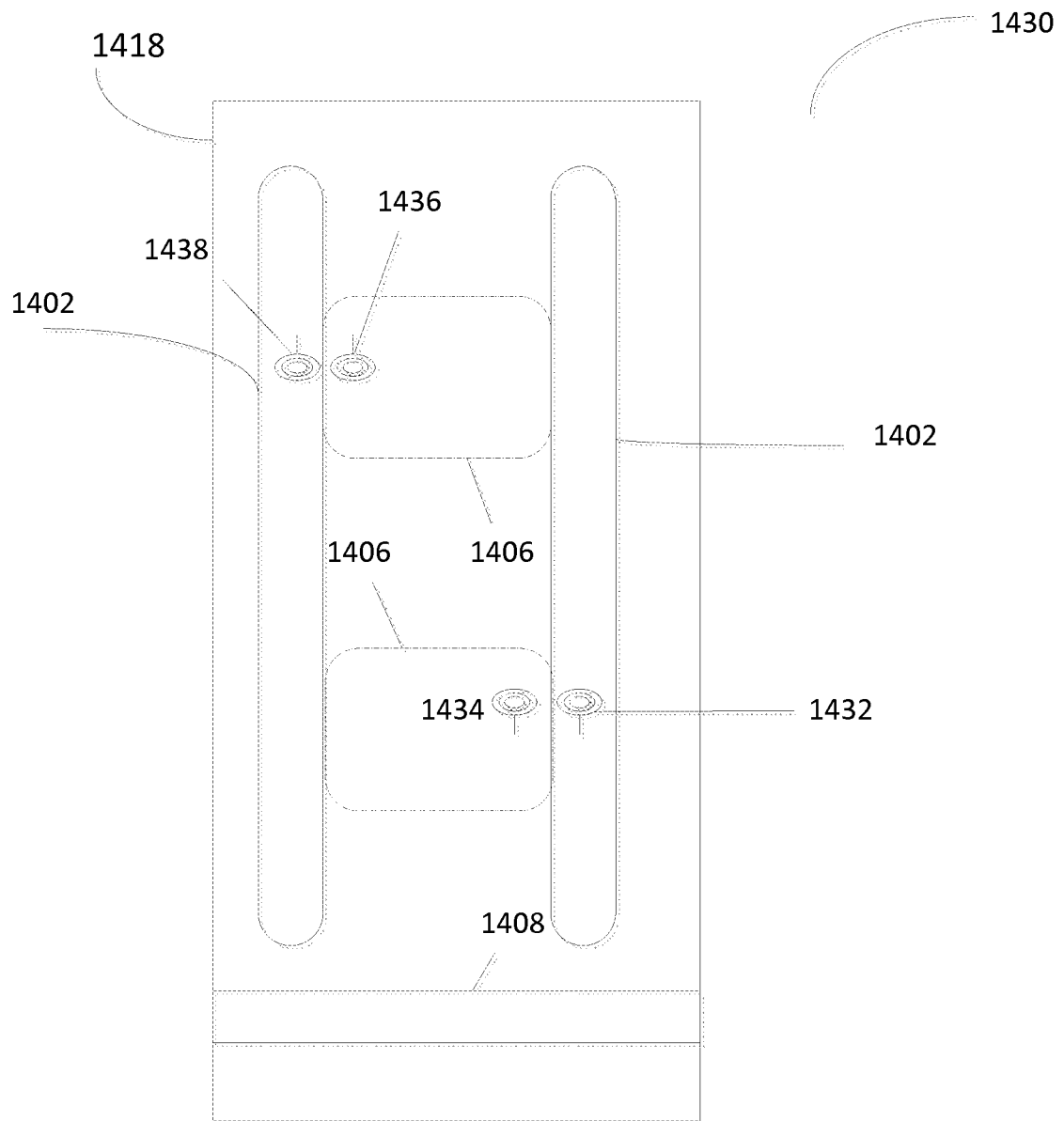

FIG. 15B

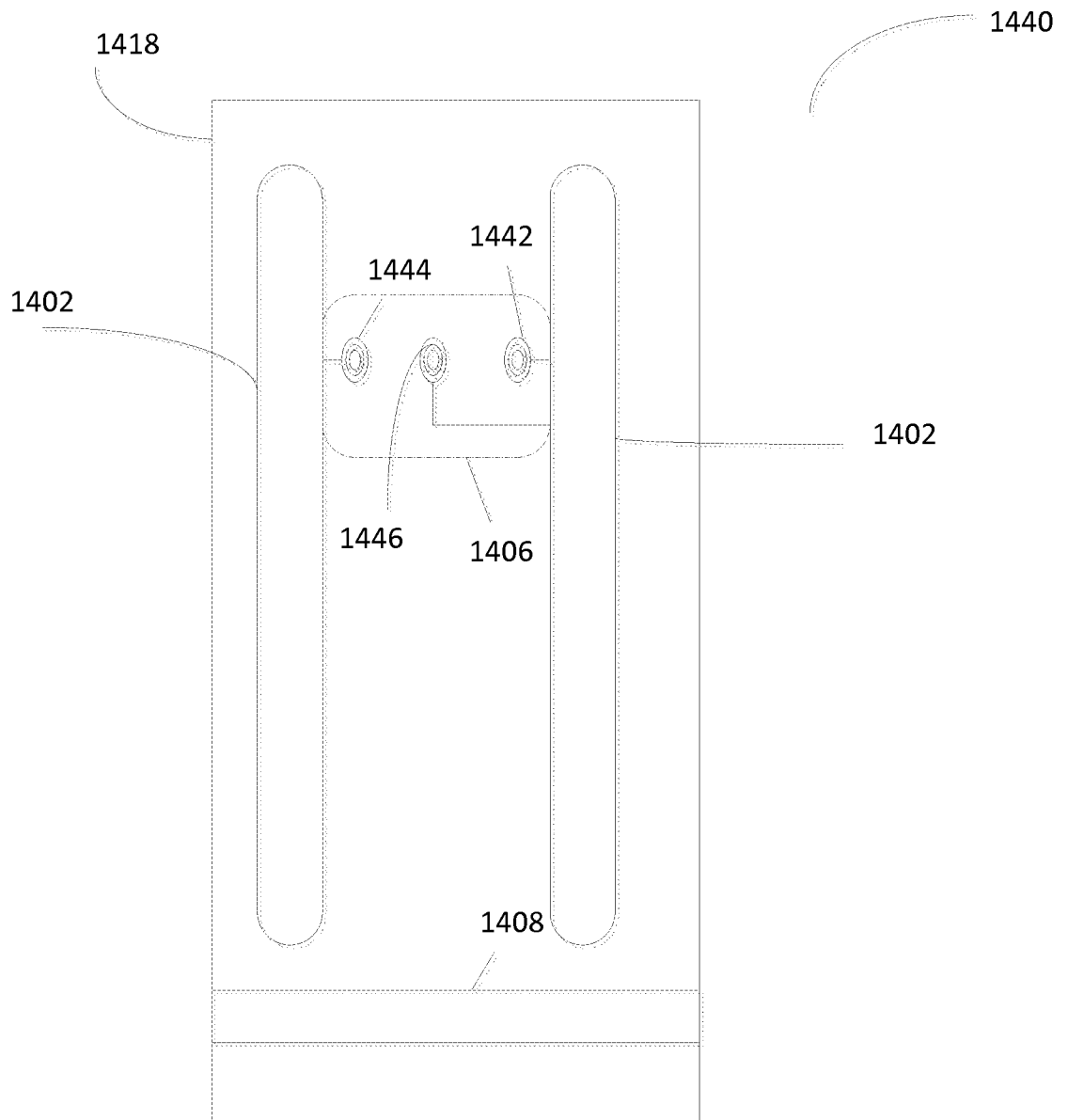

FIG. 15C

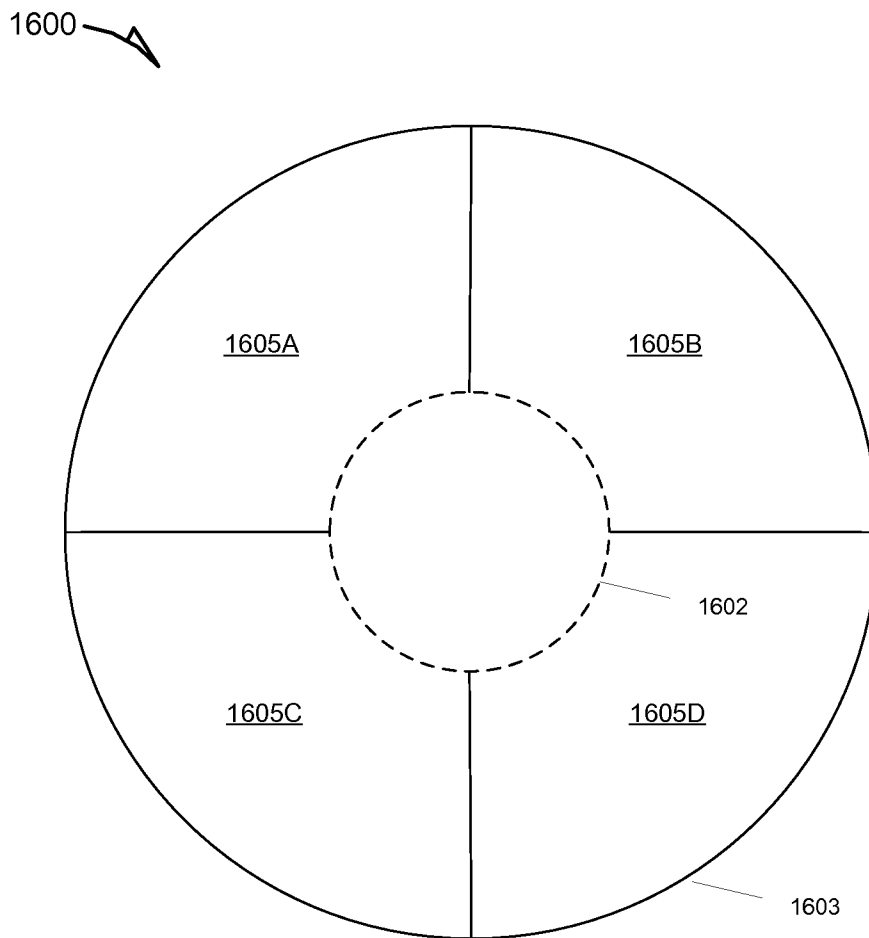

FIG. 16

19/21
1700

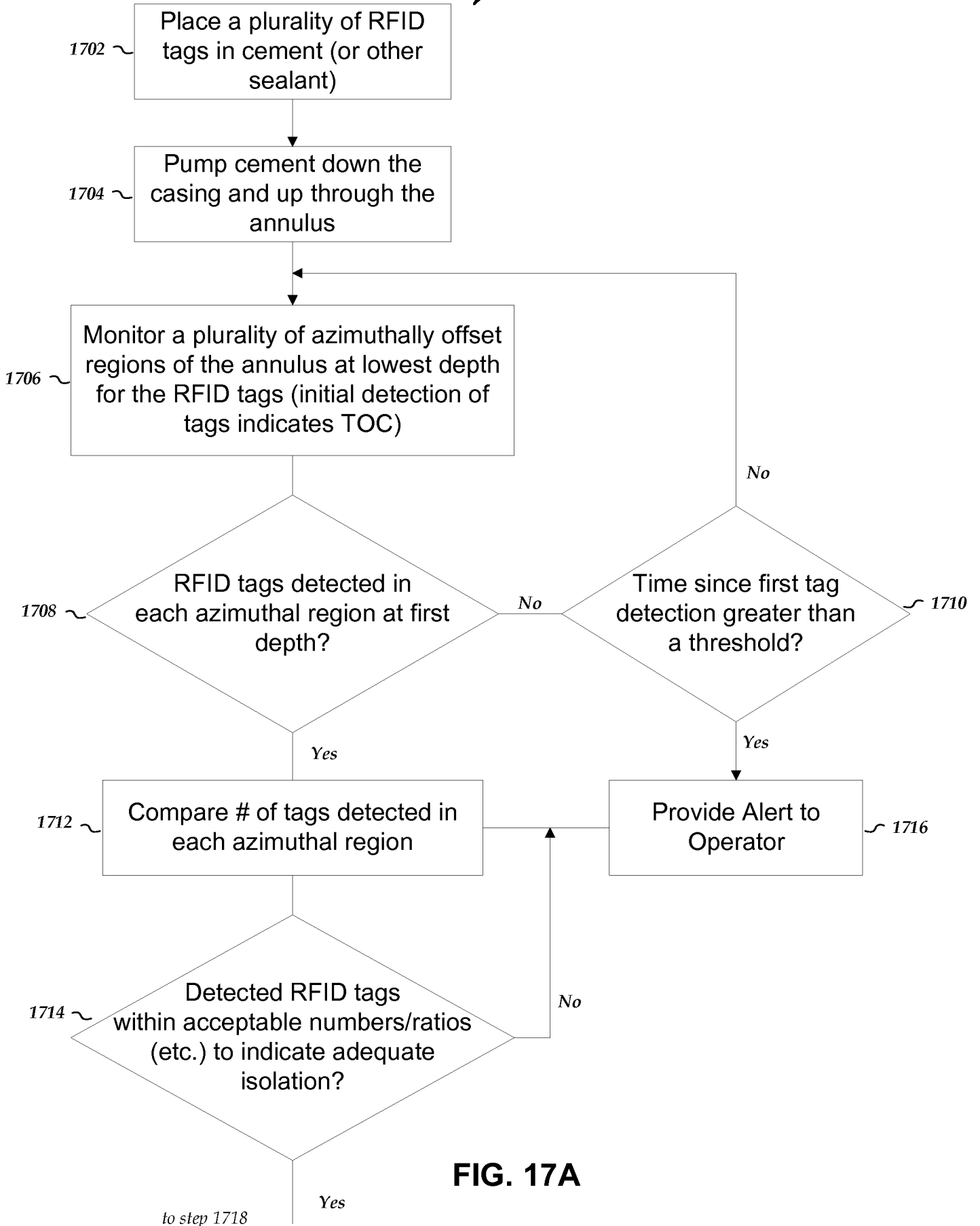

FIG. 17A

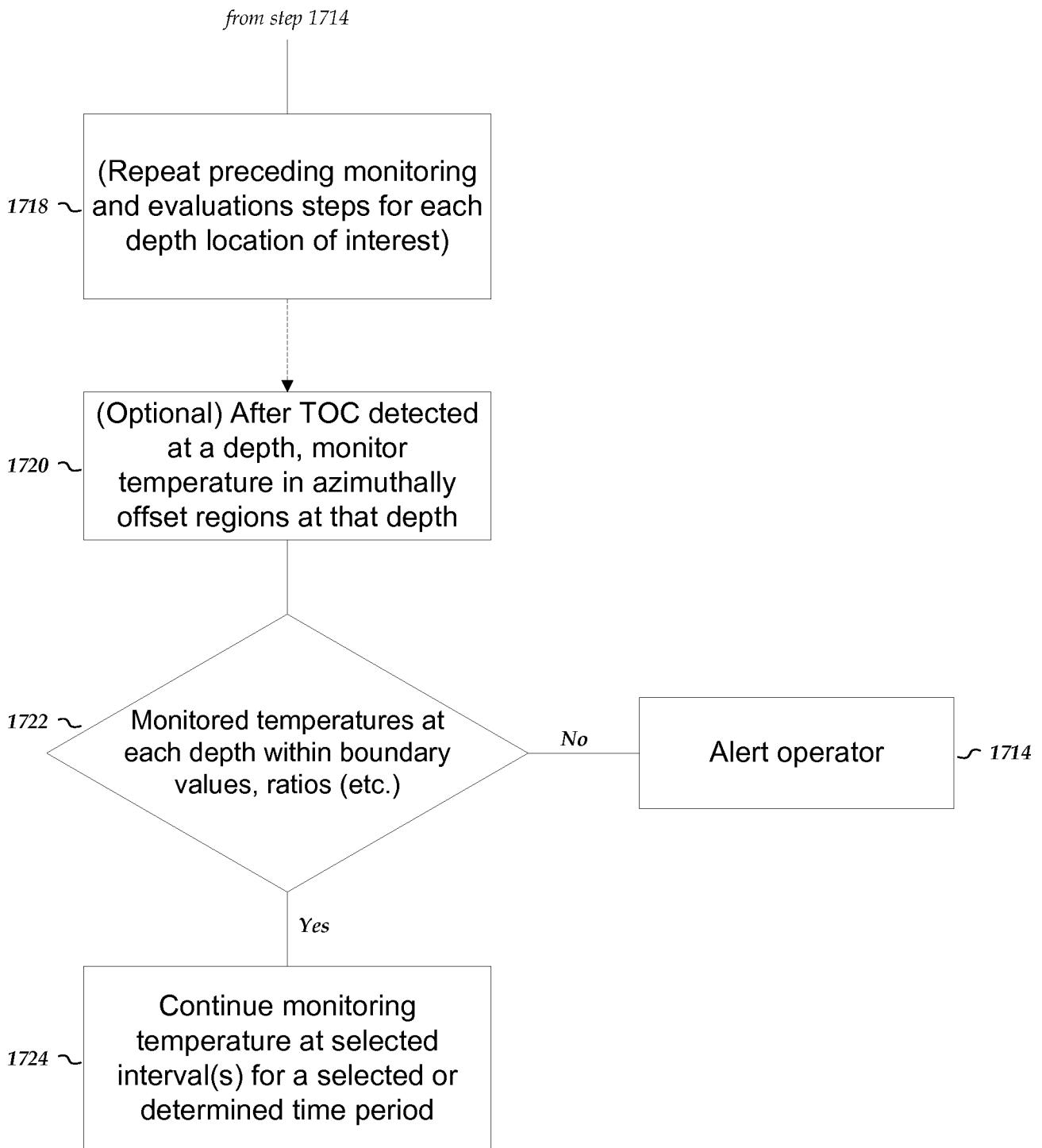

FIG. 17B

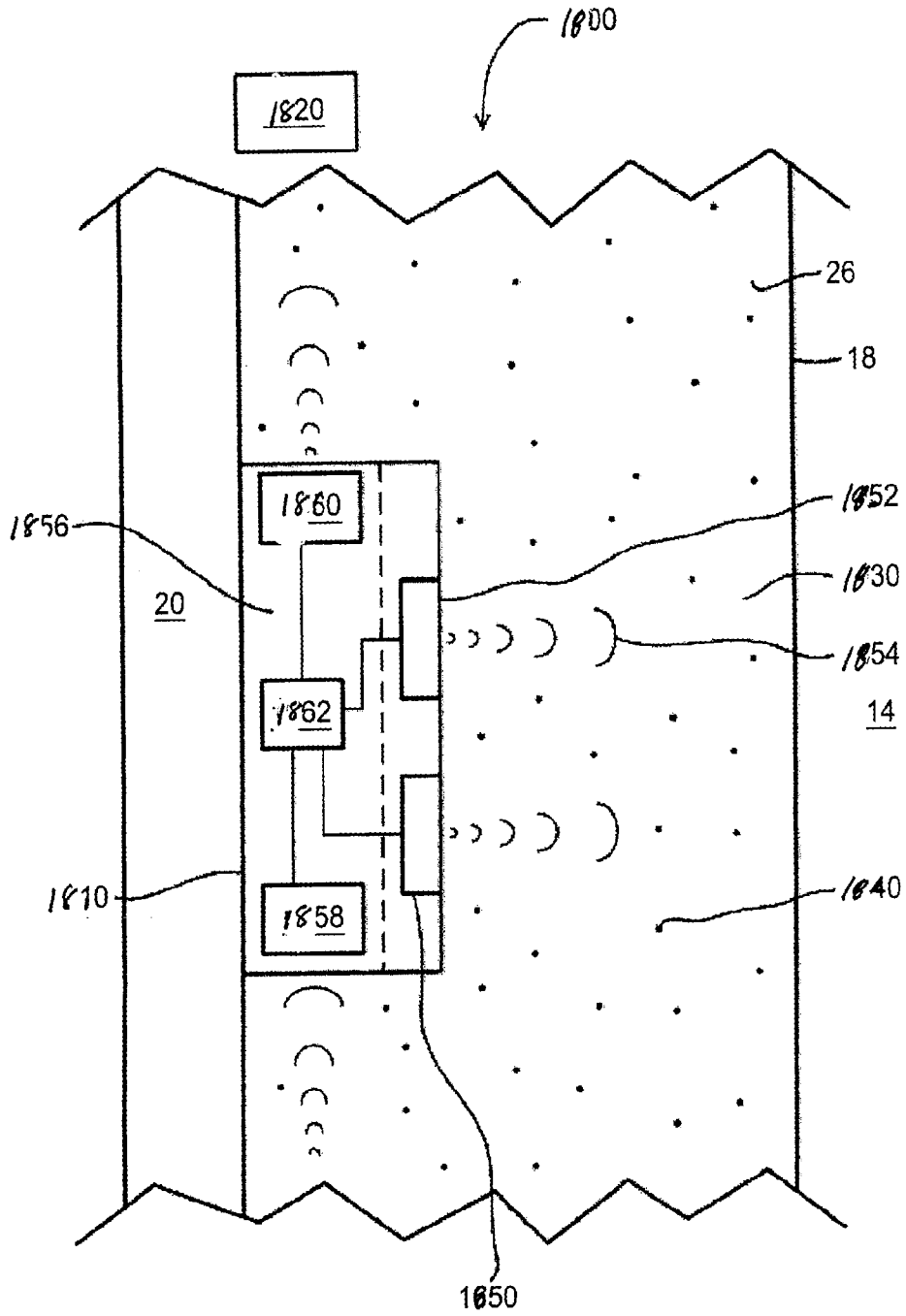

FIG. 18

INTERNATIONAL SEARCH REPORT

International application No.
PCT/US2014/072503**A. CLASSIFICATION OF SUBJECT MATTER****E21B 47/09(2006.01)i, E21B 47/12(2006.01)i, G06K 19/077(2006.01)i**

According to International Patent Classification (IPC) or to both national classification and IPC

B. FIELDS SEARCHEDMinimum documentation searched (classification system followed by classification symbols)
E21B 47/09; E21B 47/00; E21B 33/13; E21B 47/12; G06K 19/077Documentation searched other than minimum documentation to the extent that such documents are included in the fields searched
Korean utility models and applications for utility models
Japanese utility models and applications for utility modelsElectronic data base consulted during the international search (name of data base and, where practicable, search terms used)
eKOMPASS(KIPO internal) & Keywords: well, RFID tags, detection, pump, sealant, annulus, depth, azimuthal, offset, MEMS, communication assembly, controller**C. DOCUMENTS CONSIDERED TO BE RELEVANT**

Category*	Citation of document, with indication, where appropriate, of the relevant passages	Relevant to claim No.
X	US 2011-0186290 A1 (RODDY et al.) 04 August 2011 See abstract, paragraphs [0040], [0041], [0060], [0099], [0237]-[0239], and figure 32.	1-22
A	US 2011-0192594 A1 (RODDY et al.) 11 August 2011 See abstract, paragraphs [0255]-[0257], claim 1, and figure 35.	1-22
A	US 2005-0034863 A1 (DILLENBECK et al.) 17 February 2005 See abstract, paragraphs [0040], [0048], [0049], and figure 4.	1-22
A	US 2008-0236814 A1 (RODDY, CRAIG W.) 02 October 2008 See abstract, paragraphs [0041]-[0045], and figures 1, 2.	1-22
A	US 2012-0205103 A1 (RAVI et al.) 16 August 2012 See abstract, paragraphs [0016]-[0024], and figure 1.	1-22

 Further documents are listed in the continuation of Box C. See patent family annex.

* Special categories of cited documents:

"A" document defining the general state of the art which is not considered to be of particular relevance

"E" earlier application or patent but published on or after the international filing date

"L" document which may throw doubts on priority claim(s) or which is cited to establish the publication date of another citation or other special reason (as specified)

"O" document referring to an oral disclosure, use, exhibition or other means

"P" document published prior to the international filing date but later than the priority date claimed

"T" later document published after the international filing date or priority date and not in conflict with the application but cited to understand the principle or theory underlying the invention

"X" document of particular relevance; the claimed invention cannot be considered novel or cannot be considered to involve an inventive step when the document is taken alone

"Y" document of particular relevance; the claimed invention cannot be considered to involve an inventive step when the document is combined with one or more other such documents, such combination being obvious to a person skilled in the art

"&" document member of the same patent family

Date of the actual completion of the international search

20 March 2015 (20.03.2015)

Date of mailing of the international search report

01 April 2015 (01.04.2015)

Name and mailing address of the ISA/KR

International Application Division
Korean Intellectual Property Office
189 Cheongsa-ro, Seo-gu, Daejeon Metropolitan City, 302-701,
Republic of Korea

Facsimile No. ++82 42 472 7140

Authorized officer

KIM, Jin Ho

Telephone No. +82-42-481-8699



INTERNATIONAL SEARCH REPORT

Information on patent family members

International application No.

PCT/US2014/072503

Patent document cited in search report	Publication date	Patent family member(s)	Publication date
US 2011-0186290 A1	04/08/2011	AU 2012-220382 A1	05/09/2013
		CA 2827763 A1	30/08/2012
		GB 201314911 D0	02/10/2013
		GB 2505085 A	19/02/2014
		MX 2013009635 A	04/12/2013
		NO 20131262 A	21/11/2013
		US 8316936 B2	27/11/2012
		WO 2012-114068 A2	30/08/2012
		WO 2012-114068 A3	15/08/2013
		US 2011-0192594 A1	11/08/2011
US 2005-0034863 A1	17/02/2005	AU 2003-223411 A1	27/10/2003
		CA 2359998 A1	09/07/2002
		CA 2359998 C	21/04/2009
		CA 2482184 A1	23/10/2003
		CA 2482184 C	17/06/2008
		GB 2404940 A	16/02/2005
		JP 03787648 B2	21/06/2006
		JP 2005-057228 A	03/03/2005
		TW 223900 A	11/11/2004
		US 2002-0125294 A1	12/09/2002
		US 2003-0132265 A1	17/07/2003
		US 2003-0192690 A1	16/10/2003
		US 2003-0192695 A1	16/10/2003
		US 2004-0178248 A1	16/09/2004
		US 2005-0023575 A1	03/02/2005
		US 2007-0266560 A1	22/11/2007
		US 6776322 B2	17/08/2004
		US 6789619 B2	14/09/2004
		US 6802373 B2	12/10/2004
		US 6942135 B2	13/09/2005
US 6953089 B2	11/10/2005		
US 7066256 B2	27/06/2006		
US 7066371 B2	27/06/2006		
US 7154149 B2	26/12/2006		
WO 2003-087520 A2	23/10/2003		
WO 2003-087520 A3	13/01/2005		
US 2008-0236814 A1	02/10/2008	BR PI0808496 A2	22/07/2014
		CA 2771626 A1	03/03/2011
		CA 2771626 C	25/02/2014
		CA 2771698 A1	03/03/2011
		CA 2771698 C	08/04/2014
		EP 2129867 A1	09/12/2009
		EP 2129867 B1	21/08/2013
		EP 2336487 A1	22/06/2011
		EP 2336487 B1	30/10/2013
		EP 2343434 A1	13/07/2011

INTERNATIONAL SEARCH REPORT

Information on patent family members

International application No.

PCT/US2014/072503

Patent document cited in search report	Publication date	Patent family member(s)	Publication date
		EP 2489828 A1	22/08/2012
		EP 2489829 A1	22/08/2012
		EP 2489829 B1	16/04/2014
		GB 2486138 A	06/06/2012
		GB 2487856 A	08/08/2012
		US 2010-0050905 A1	04/03/2010
		US 2010-0051266 A1	04/03/2010
		US 2010-0051275 A1	04/03/2010
		US 7712527 B2	11/05/2010
		US 8083849 B2	27/12/2011
		US 8162055 B2	24/04/2012
		US 8342242 B2	01/01/2013
		WO 2008-119963 A1	09/10/2008
		WO 2011-023938 A1	03/03/2011
		WO 2011-023942 A2	03/03/2011
		WO 2011-023942 A3	16/06/2011
		WO 2011-058324 A1	19/05/2011
US 2012-0205103 A1	16/08/2012	AU 2012-216882 A1	30/05/2013
		EP 2675993 A1	25/12/2013
		US 8636063 B2	28/01/2014
		WO 2012-110762 A1	23/08/2012