

W. P. DODSON.  
 Railroad Switch.

No. 233,146.

Patented Oct. 12, 1880.

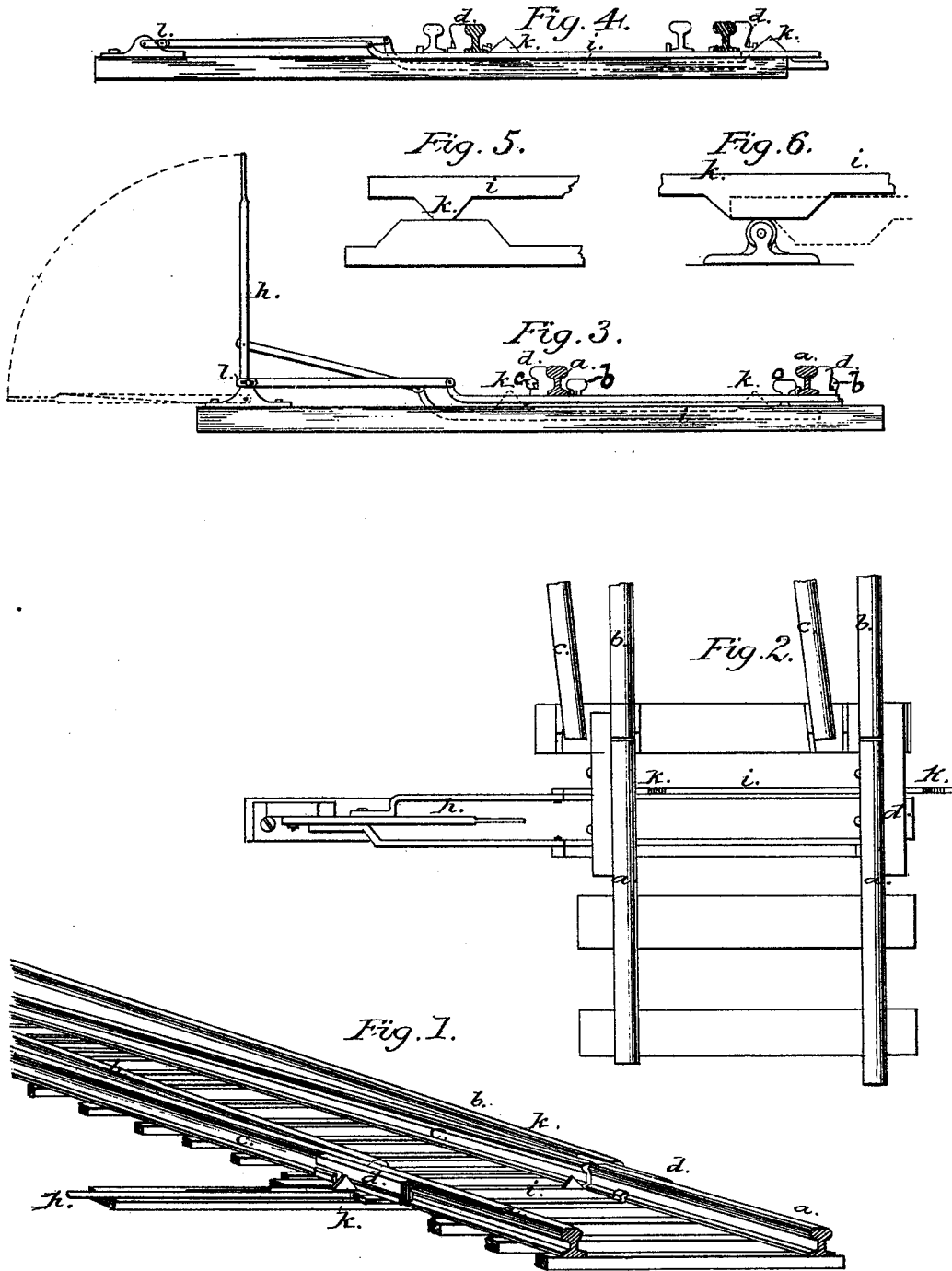

Witnesses:  
 Saml P. Hanson  
 John S. Badger

Inventor:  
 Wilson P. Dodson  
 Per  
 E. Mason, Esq.

# UNITED STATES PATENT OFFICE.

WILSON P. DODSON, OF PHILADELPHIA, ASSIGNOR OF ONE-HALF OF HIS  
RIGHT TO ALEXANDER H. EGE, OF MECHANICSBURG, PA.

## RAILROAD-SWITCH.

SPECIFICATION forming part of Letters Patent No. 233,146, dated October 12, 1880.

Application filed February 20, 1880.

To all whom it may concern:

Be it known that I, WILSON P. DODSON, of Philadelphia, in the county of Philadelphia and State of Pennsylvania, have invented a new and useful Improvement in Railroad-Switches, of which the following is a specification.

My invention relates to an improvement in railroad-switches of the class known as the "stub-switch."

In all the figures of the drawings, *a a* represent the switch-rails, and *b b c c* represent the permanent rails—one of the main line, the other of the siding.

Figure 1 is a perspective view of a switch open to the left, having at the moving ends of the switch-rails carrying-rails attached to them, which carrying-rails extend past the ends of the permanent rails and lie outside of them, so that they at once bridge the gap between the ends of the switch-rails and the ends of the permanent rails and lock the switch. *h* is the switch-lever, and *k k* are the cams of the raising-bar *i*, by which the rail ends are raised so that the ends of the carrying-rails can be moved over the ends of the permanent rails.

Fig. 2 is a plan of the switch, showing the switch open to the right, and showing the cams *k k* also on that side.

Fig. 3 is a sectional elevation, showing the switch midway in the act of motion, with dotted lines showing its position when open to the left. *e* indicates the slot in the old and ordinary rod connecting the switch-rails to the lever *h*, by which slot the proper timing of the motions is attained.

Fig. 4 is a sectional elevation, showing the switch open to the right.

Fig. 5 is a sectional view, showing one end of the raising-bar *i*, with the cams *k k* reversed, raising the bar with the rails in its lateral motion, instead of raising the rails only, as in the former figures.

Fig. 6 is a sectional view, showing the one end of raising-bar *i*, with its cams below, as in Fig. 5, having the cam elongated and moving upon a wheel placed in a chair below it, so that the friction incident to its motion is reduced.

The stub-switch, as it has been heretofore ordinarily constructed, has been found liable

to the difficulties that when expanded in hot weather the rails were liable to jam, and when contracted by cold a gap was left between the rail ends, causing rails and rolling-stock to be battered, and also that the switch, being held in place only by the lever, was liable to be displaced if the lever was not securely fastened, thus causing accidents.

In order to obtain a smooth passage of the wheels over the gap, and at the same time to lock the switch securely in whatever position it may be placed, I attach to the moving ends of the switch-rails, and to the outer side of them, carrying-rails, which extend sufficiently above the line of the rails to take the outer part of the tread of the wheels, and sufficiently beyond their ends to pass beyond the ends of the permanent rails, and which are preferably made with a gradual rise at either end, so that they will take the tread of the wheels without shock before the wheels reach the gap.

I cut away the lower part of those ends of the carrying-rails which cover the gap and lap over the permanent rails, and provide a proper support on which those ends shall rest. It is not absolutely necessary that the lower part of these ends of the carrying-rails be cut away; but if not so done they will require to be raised higher, necessitating the exercise of more force. As thus constructed the carrying-rails rest outside the pair of permanent rails with which the switch-rails are in connection, and at the same time bridge the gap and hold the switch in place.

If the ends of the switch-rails shall be raised so that the ends of the carrying-rails shall clear the ends of the permanent rails, the switch-rails can be moved over to connect with the other line of rails, and being lowered the carrying-rails will rest outside of that pair of rails and will hold the switch in place and bridge the gap as before. To accomplish this result I place under the ends of the switch-rails a bar, *i*, provided with cams *k k*, by the lateral movement of which bar the ends of the switch-rails are raised a sufficient distance for the purpose designated. If, now, this bar be moved so as to raise these rail ends, and then the switch-rails so raised be moved laterally, the ends of the carrying-rails will pass over

the ends of the permanent rails, and when the switch-rails are brought in line with the other pair of permanent rails and lowered the proper connection will be made. To accomplish this result at one operation I attach the raising-bar by a connecting-rod to the ordinary switch-lever; and in order to attain the proper timing of the motions, that the rail ends may be raised before they are moved laterally, I put in the old connecting-rod, by which the lever is attached to the switch-rails and moves them, a slot, *l*, so that a certain and sufficient amount of lost motion is allowed to the lever in connection with the lateral movement of the switch, and the rail ends are first raised and then moved laterally.

The raising-bar may have cams acting directly upon the under side of the rail, as shown in Figs. 1, 2, 3, and 4, or it may be flat on top and have cams below acting upon fixed inclined surfaces, as shown in Fig. 5, and it, or the bearing below it, may be furnished with wheels to save friction, as shown in Fig. 6, so that it raises the ends of the switch-rails and holds them raised till they have passed the

ends of the permanent rails, and the lost motion, by means of which the actions are properly timed, may be secured by other well-known mechanical devices besides the slot described, so that the actions shall be properly timed, as described.

I claim as my invention—

1. In combination with the moving ends of switch-rails, the carrying-rails attached thereto, whose ends extend past the ends of the permanent rails and lock the switch, substantially as specified.

2. In combination with the moving ends of switch-rails, the independently-moving raising-bar *i*, constructed and operating substantially as specified.

3. In combination with the moving ends of switch-rails and the raising-bar, the slotted connecting-rod or its equivalent, substantially as specified.

WILSON P. DODSON.

Witnesses:

GEORGE HOUSE,  
G. MORGAN ELDRIDGE.