



- (51) International Patent Classification:  
A61B 18/14 (2006.01)
- (21) International Application Number:  
PCT/EP2012/056626
- (22) International Filing Date:  
12 April 2012 (12.04.2012)
- (25) Filing Language: English
- (26) Publication Language: English
- (30) Priority Data:  
GE2011A000043 18 April 2011 (18.04.2011) IT
- (71) Applicant (for all designated States except US):  
DASTOLI, Giuseppe [IT/IT]; Via Foscolo, 24, I-27100 Pavia (IT).
- (72) Inventors; and
- (71) Applicants : CHIERCHIA, Gian Battista [IT/BE]; Rue Jules LeJeune 37, B-1050 Bruxelles (BE). PERFLER, Enrico [IT/IT]; Via Roma, 124, I-16033 LAVAGNA, Province of Genova (IT).
- (74) Agent: PORSIA, Attilio; Succ. Ing. Fischetti & Weber, 3/2, Via Caffaro, I-16124 Genova (IT).

- (81) Designated States (unless otherwise indicated, for every kind of national protection available): AE, AG, AL, AM, AO, AT, AU, AZ, BA, BB, BG, BH, BR, BW, BY, BZ, CA, CH, CL, CN, CO, CR, CU, CZ, DE, DK, DM, DO, DZ, EC, EE, EG, ES, FI, GB, GD, GE, GH, GM, GT, HN, HR, HU, ID, IL, IN, IS, JP, KE, KG, KM, KN, KP, KR, KZ, LA, LC, LK, LR, LS, LT, LU, LY, MA, MD, ME, MG, MK, MN, MW, MX, MY, MZ, NA, NG, NI, NO, NZ, OM, PE, PG, PH, PL, PT, QA, RO, RS, RU, RW, SC, SD, SE, SG, SK, SL, SM, ST, SV, SY, TH, TJ, TM, TN, TR, TT, TZ, UA, UG, US, UZ, VC, VN, ZA, ZM, ZW.
- (84) Designated States (unless otherwise indicated, for every kind of regional protection available): ARIPO (BW, GH, GM, KE, LR, LS, MW, MZ, NA, RW, SD, SL, SZ, TZ, UG, ZM, ZW), Eurasian (AM, AZ, BY, KG, KZ, MD, RU, TJ, TM), European (AL, AT, BE, BG, CH, CY, CZ, DE, DK, EE, ES, FI, FR, GB, GR, HR, HU, IE, IS, IT, LT, LU, LV, MC, MK, MT, NL, NO, PL, PT, RO, RS, SE, SI, SK, SM, TR), OAPI (BF, BJ, CF, CG, CI, CM, GA, GN, GQ, GW, ML, MR, NE, SN, TD, TG).

Published: — with international search report (Art. 21(3))

(54) Title: ADAPTABLE DEVICE FOR ELECTRICALLY ISOLATING PULMONARY VEINS IN ATRIAL FIBRILLATION

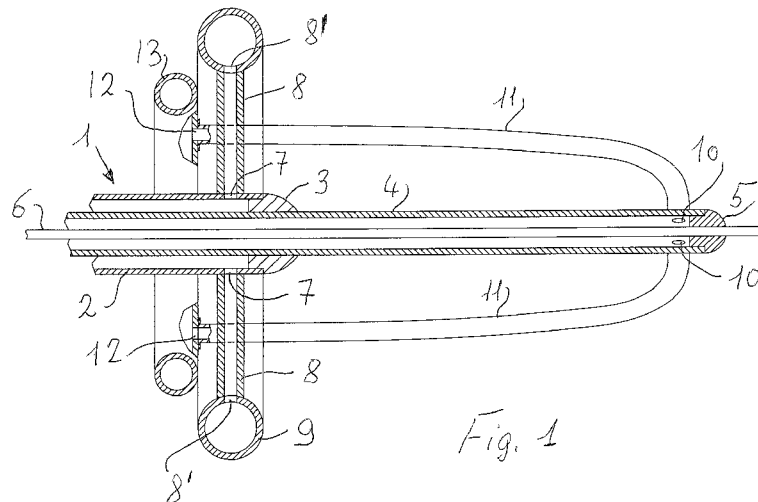

Fig. 1

(57) Abstract: Device for electrically isolating the pulmonary veins in atrial fibrillation for treatment thereof by means of ablation of a circumferential zone of tissue in a position where a pulmonary vein extends from an atrium, comprising: a catheter (1) having a terminal part and a distal part and comprising a first tubular element (2); a second tubular element (4) concentric with said first tubular element (2) and an axial rod-like element (6) which extends beyond the distal end of said first and second tubular elements (2; 4); a first tubular toroidal element (13) supported by a plurality of tubular arms (11) which extend from said distal end towards said toroidal element (13) forming a kind of cage which can be opened in umbrella fashion around the distal end of said catheter (1), said tubular arms (11) and said toroidal element (13) being in fluid communication with each other and with said second tubular element (4) of said catheter (1); and a second toroidal tubular element (9) in fluid communication by means of the radial arms (8) with said first tubular element (2) of said catheter (1), all of which so that in a first operating condition said first and second toroidal elements (13; 9) with the associated tubular arms (11) are deflated and made to adhere to said distal end of the catheter; in a second operating condition said distal end of the catheter is inserted inside the orifice of a pulmonary vein (18) and a fluid is pumped into said first toroidal element (13) and into said arms (11)

[Continued on next page]

---

so as to position said arms against the orifice of the said pulmonary vein (18); and in the third operating condition an ablation element is introduced and/or activated inside said second toroidal element (9), inflating it and bringing it into contact with the orifice (18") of the said pulmonary vein (18) for ablation of a circular zone of tissue around the orifice of the said vein.

**TITLE:** Adaptable device for electrically isolating pulmonary veins in atrial fibrillation

**DESCRIPTION**

The present invention relates to a device for the treatment of atrial fibrillation by means of an ablation method performed using a catheter inserted into the orifice of pulmonary veins.

In the context of intracardial ablation applications, the term "ablation" is understood as meaning a sufficient alteration of the properties of the tissue such as to stop substantially the conduction of electrical signals from and through the ablated cardiac tissue.

The published patent application US 2005/0165391 A1 discloses an ablation device for electrically isolating the orifice of a pulmonary vein from an atrial wall by means of a catheter comprising a circumferential ablation element comprising a plurality of form-memory metallic filaments adjustable between different configurations so as to allow their introduction into the atrium and ablative engagement between the ablation elements and the circumferential tissue zone. The use of these form-memory metallic filaments, however, gives rise to numerous problems in connection with their precise adjustment in the tissue zone to be ablated, owing to the reduced flexibility of said rigid or semi-rigid structures. Moreover the presence of rigid metallic structures may easily cause damage to the tissue.

The object of the present invention is therefore to provide a device which allows the treatment of atrial fibrillation by means of an ablation method performed using a catheter inserted into the orifice of the pulmonary veins, where all the positioning and

ablation operations are performed using inflatable filament-like tubes.

This object is achieved by means of a device as claimed in Claim 1.

Further objects and advantages of the device according to the present invention will emerge more clearly during the course of the following description of a preferred embodiment thereof, provided with reference to the accompanying drawings in which:

Figure 1 is a longitudinally sectioned side view, on a larger scale, of the distal end of a catheter according to the invention with the tubular elements partially inflated;

Figure 2 is a side view of the distal end of the catheter according to Figure 1, with the tubular elements almost completely deflated;

Figure 3 is a front view of the distal end of the catheter according to Figures 1 and 2, with the tubular elements inflated;

Figure 4 shows the passage of the catheter according to the invention from the right atrium of the heart into the left atrium through the interatrial septum;

Figure 5 shows the introduction of the catheter according to the invention into one of the pulmonary veins emerging inside said atrium;

Figure 6 shows the positioning of the inflatable cage of the catheter inside the mouth of said pulmonary vein; and

Figure 7 shows the inflation of the annular element for cryoablation of the orifice of said vein.

As is known, the heart has two upper cavities called "right atrium and left atrium" separated by a wall called "interatrial

septum". The two venae cavae and the coronary sinus emerge inside the right atrium, while the four pulmonary veins which convey the blood oxygenated in the lungs emerge inside the left atrium.

During the normal heartbeat the impulse generated by the sinoatrial node causes contraction of the heart muscle and allows pumping of the blood. In atrial fibrillation, the electrical impulses which give rise to contraction of the atria are activated in a totally random and fragmentary manner, resulting in multiple wave fronts and disorganized and fragmentary contractions. These contractions of the atria are often inefficient from a haemodynamic point of view and therefore do not allow the heart to perform its pumping function in an efficient manner.

Many means for restoring the sinus rhythm or "cardioversion" of the heart, such as pharmacological or electrical cardioversion, have been proposed. Recently transcatheter ablation has also been introduced with success, this technique being used to interrupt the electrical transmission from the pulmonary veins to the left atrium.

With reference now to the drawings and with reference to Figures 1 to 3 thereof, 1 denotes a catheter according to the invention. This catheter 1 comprises a first tubular element 2 which extends from the proximal end (not shown) to the distal end thereof, which is closed by a closing element 3. A second tubular element 4 is housed coaxially with said tubular element 2 and extends from the proximal end (not shown) to the distal end thereof, passing through the closing element 3, so as to terminate at a short distance from the latter with a second closing element 5.

The catheter is completed by a third, relatively rigid, rod-like, central element 6 which extends from the proximal end of the catheter, passing concentrically through the tubular element 4 externally through the closing element 5.

The tubular element 2 has, upstream of the closing element 3 and in the vicinity thereof, four radial holes 7 arranged in the same plane and staggered at 90° relative to each other, communicating via a corresponding number of tubular radial elements 8 and the holes 8' with a toroidal tubular element 9 which is coaxial with the tubular element 2, for the purposes which will be explained below.

The tubular element 4 has, upstream of the closing element 5 in the vicinity thereof, four holes 10 communicating with four tubular elements 11 which extend behind beyond the plane defined by the toroidal element 9 so as to be connected via the holes 12 in fluid communication with a toroidal element 13 which has a diameter smaller than the diameter of the toroidal element 9. The holes 10, and therefore the tubular elements 11, are staggered by 45° with respect to the holes 7, and therefore with respect to the tubular elements 8, as is shown more clearly in Figure 3. The toroidal element 13 also has a series of radio-opaque markers 14 for the purposes which will be described below.

During operation, the device described is completely deflated, as shown in Figure 2, and retracted along the tubular elements 4 and 2 of the catheter 1. At this point the catheter thus prepared is introduced, by passing it down from the upper vein into the foramen ovale in the right atrium 15 of the patient's heart (see Figures 4 and 5) and from here, after perforation of the

interatrial septum 16, into the left atrium 17 of the patient's heart where the pulmonary veins emerge, entering in sequence (Figure 5) each pulmonary vein 18, 18' for the ablation treatment.

Owing to the presence of the radio-opaque markers 14, the optimum positioning of the device is greatly facilitated. At this point, fluid is injected through the tubular element 4 of the catheter. This fluid then flows from the proximal end of the tube 4 to its distal end and from here through the holes 10 into the arms 11 and from the latter through the holes 12 into the toroidal element 13 which are thus inflated. Owing to the independent movement of the arms 11 of the system positioning cage, the latter perfectly adapts to the anatomy of the pulmonary vein concerned, allowing the resilient inflatable chamber to adapt to the dimensions and form of the orifice (Figure 6).

At this point the cryogenic fluid is introduced, via the tubular element 1, holes 7, radial tubes 8 and holes 8', into the cryothermal chamber 9 which is thus inflated (Figure 7) so as to cause it to rest circumferentially on the orifice 18" of the pulmonary vein 18, thus performing cryoablation of the tissue at the orifice of said vein.

At this point, both the cryothermal chamber 9 and the positioning cage 11, 13 are deflated again, and the catheter may again be extracted, passing it along the same path in the reverse direction.

The advantages of the present device will be clear: owing to the cage formed by the arms 11 and the toroidal element 13 which can be inserted into the mouth of the pulmonary vein, the device can be stably and precisely positioned in relation to the tissue to

be ablated, also owing to the presence of the radio-opaque markers 14. Moreover, this cage may also be inflated with a radio-opaque liquid so as to facilitate even more precise positioning thereof with respect to the tissue to be ablated.

In particular, although in the description above the use of a cryogenic fluid as ablation element has been described purely by way of an example, it is understood that this ablation element may be an electrically powered ablation element; a thermal ablation element; an ultrasound ablation element; a microwave ablation element; a fluid-type ablation element; a light-emitting ablation element or generally an ablation element which uses any form of energy available.

Therefore the present invention is not limited to the embodiment shown and described, but comprises all those variations and modifications which fall within the wider scope of the inventive idea, substantially as claimed below.

## CLAIMS

- 1) Device for electrically isolating the pulmonary veins in atrial fibrillation for treatment thereof by means of ablation of a circumferential zone of tissue in a position where a pulmonary vein extends from an atrium, comprising:  
a catheter (1) having a terminal part and a distal part and comprising a first tubular element (2); a second tubular element (4) concentric with said first tubular element (2) and an axial rod-like element (6) which extends beyond the distal end of said first and second tubular elements (2; 4); a first tubular toroidal element (13) supported by a plurality of tubular arms (11) which extend from said distal end towards said toroidal element (13) forming a kind of cage which can be opened in umbrella fashion around the distal end of said catheter (1), said tubular arms (11) and said toroidal element (13) being in fluid communication with each other and with said second tubular element (4) of said catheter (1);  
and a second toroidal tubular element (9) in fluid communication by means of the radial arms (8) with said first tubular element (2) of said catheter (1), all of which so that in a first operating condition said first and second toroidal elements (13; 9) with the associated tubular arms (11) are deflated and made to adhere to said distal end of the catheter; in a second operating condition said distal end of the catheter is inserted inside the orifice of a pulmonary vein (18) and a fluid is pumped into said first toroidal element (13) and into said arms (11) so as to position said arms against the orifice of the said pulmonary vein (18); and in the third operating

condition an ablation element is introduced and/or activated inside said second toroidal element (9), inflating it and bringing it into contact with the orifice (18") of the said pulmonary vein (18) for ablation of a circular zone of tissue around the orifice of the said vein.

- 2) Device according to Claim 1, wherein said ablation element comprises a cryoablation element.
- 3) Device according to Claim 1, wherein said ablation element comprises an electrically powered ablation element.
- 4) Device according to Claim 1, wherein said ablation element comprises a thermal ablation element.
- 5) Device according to Claim 1, wherein said ablation element comprises an ultrasound ablation element.
- 6) Device according to Claim 1, wherein said ablation element comprises a microwave ablation element.
- 7) Device according to Claim 1, wherein said ablation element comprises a fluid-type ablation element.
- 8) Device according to Claim 1, wherein said ablation element comprises a light-emitting ablation element.
- 9) Device according to Claim 1, wherein said arms (11) are provided with radio-opaque markers.
- 10) Device according to Claim 1, wherein a radio-opaque fluid is pumped into said arms (11).
- 11) Device according to Claim 1, wherein said first and said second toroidal elements (13, 9) and said arms (11; 8) are made of resilient material.

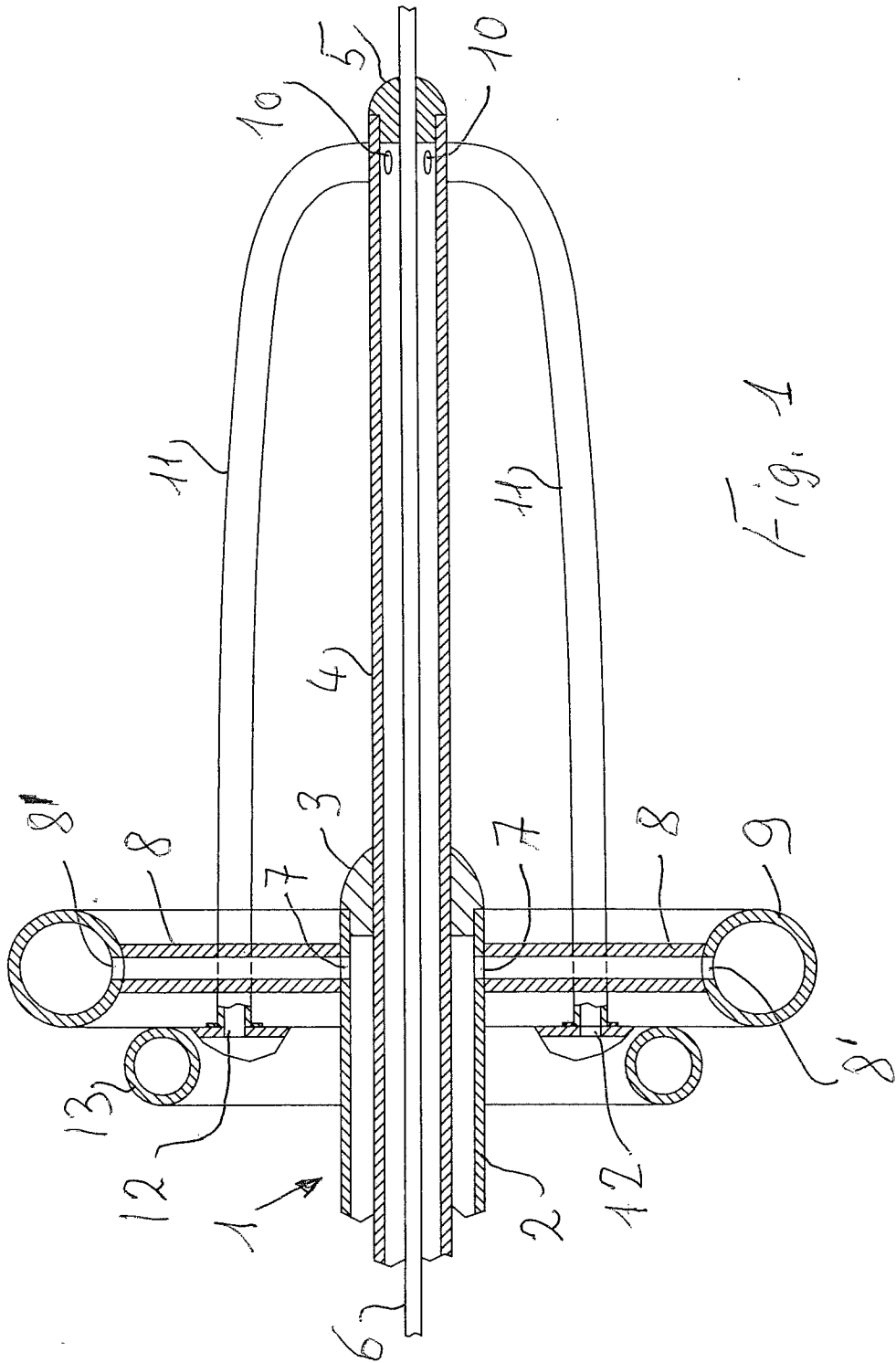

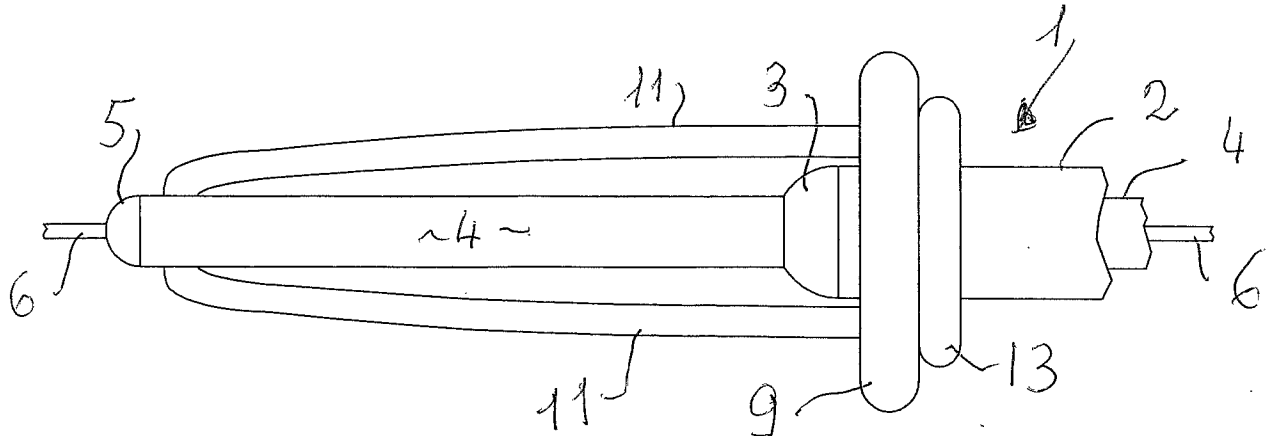

Fig. 2

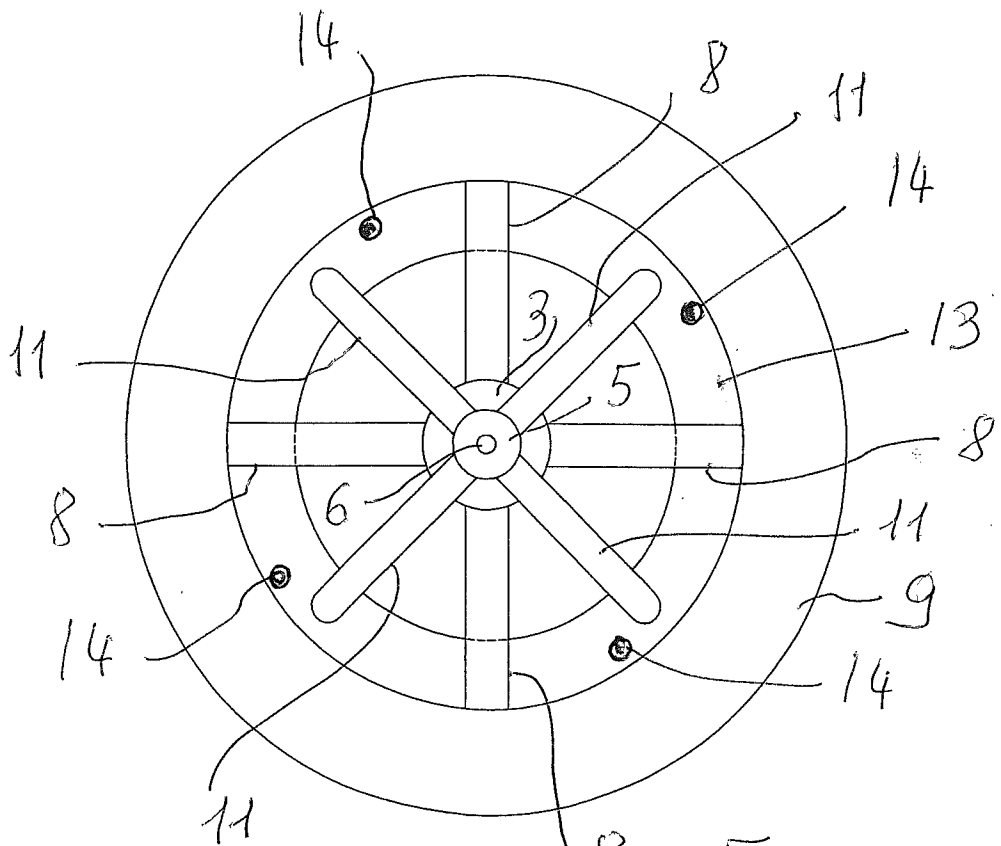

Fig. 3

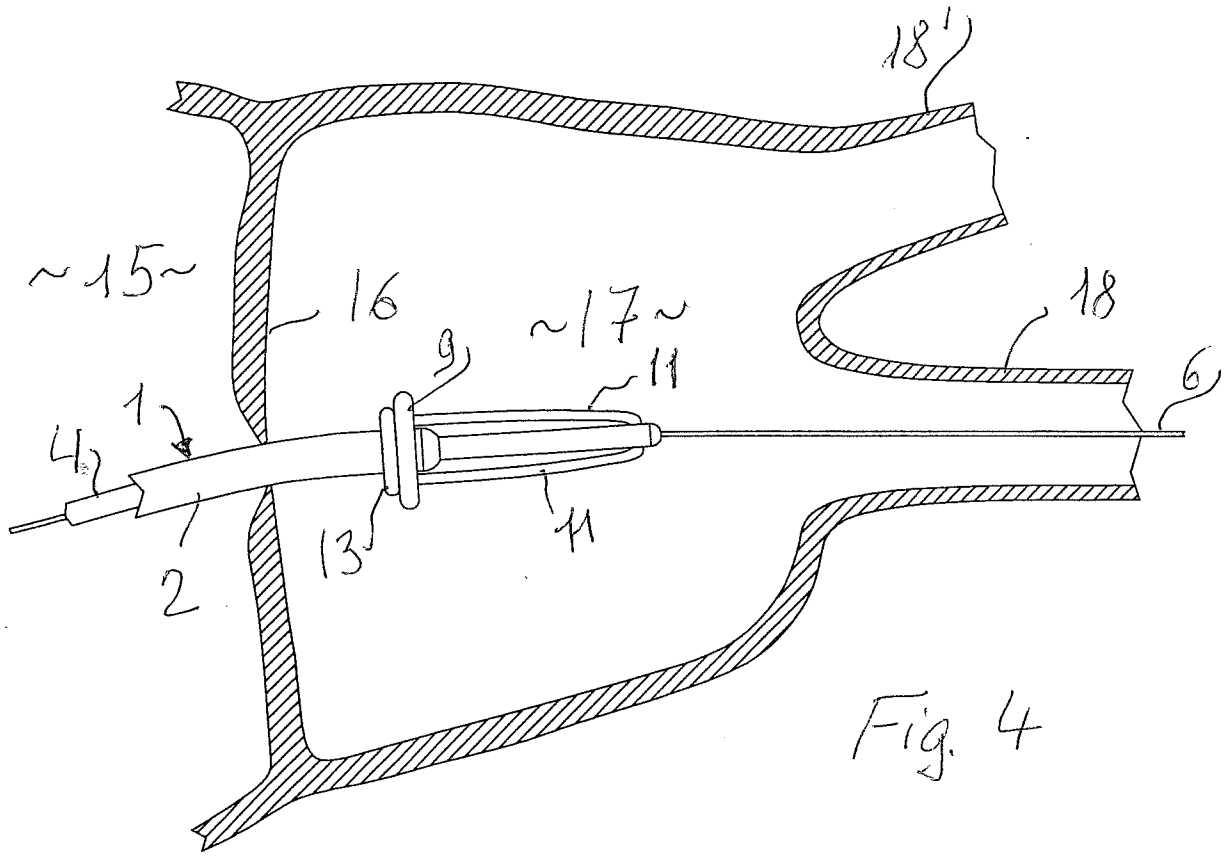

Fig. 4

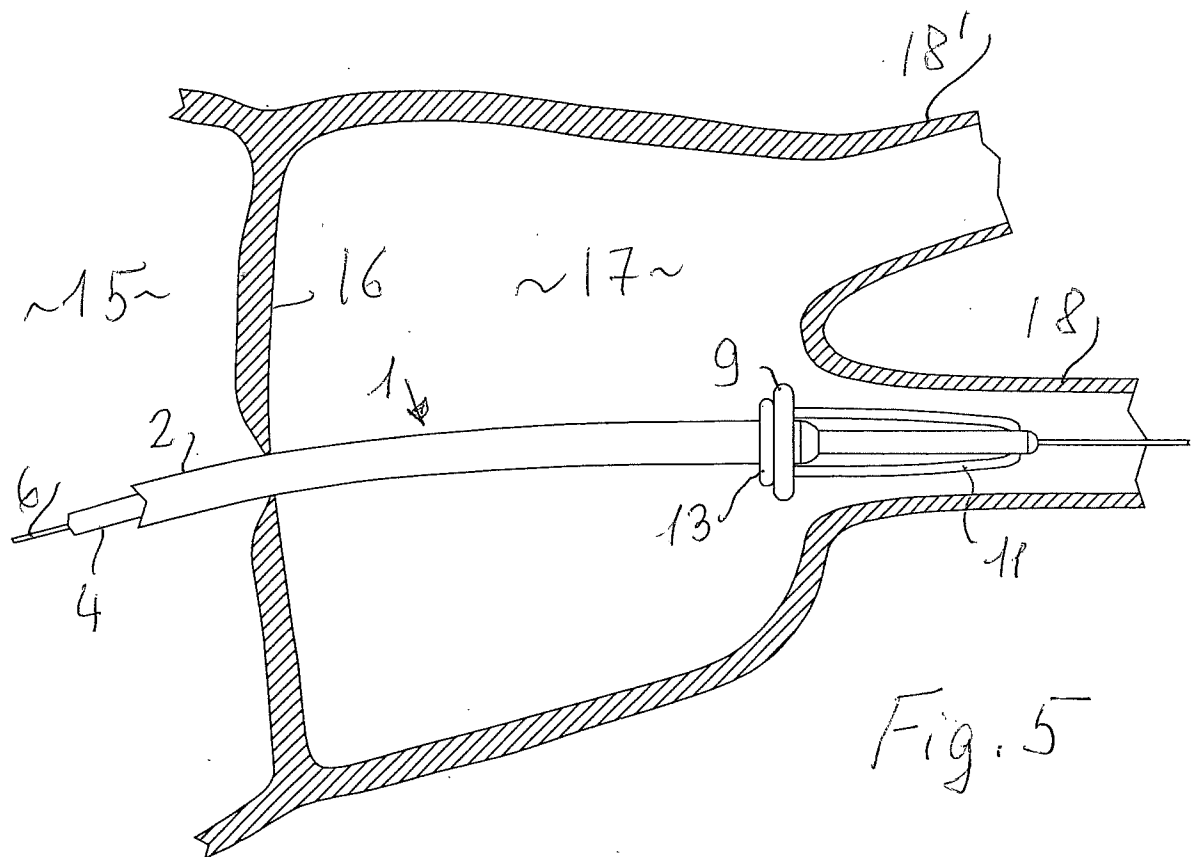

Fig. 5

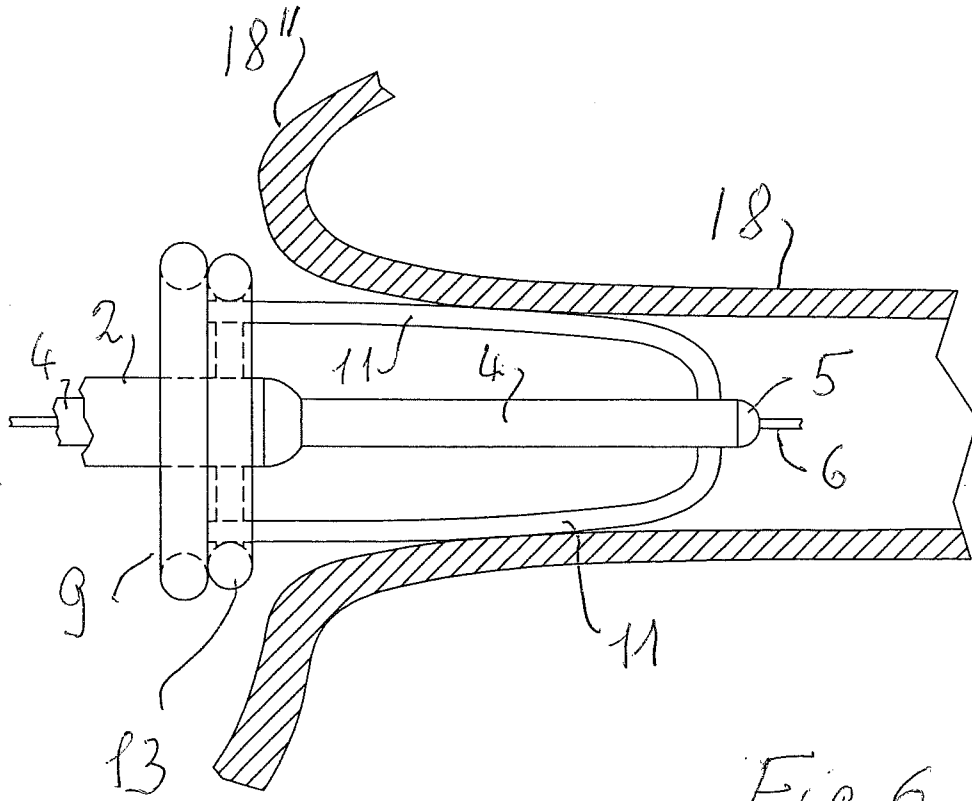

Fig. 6

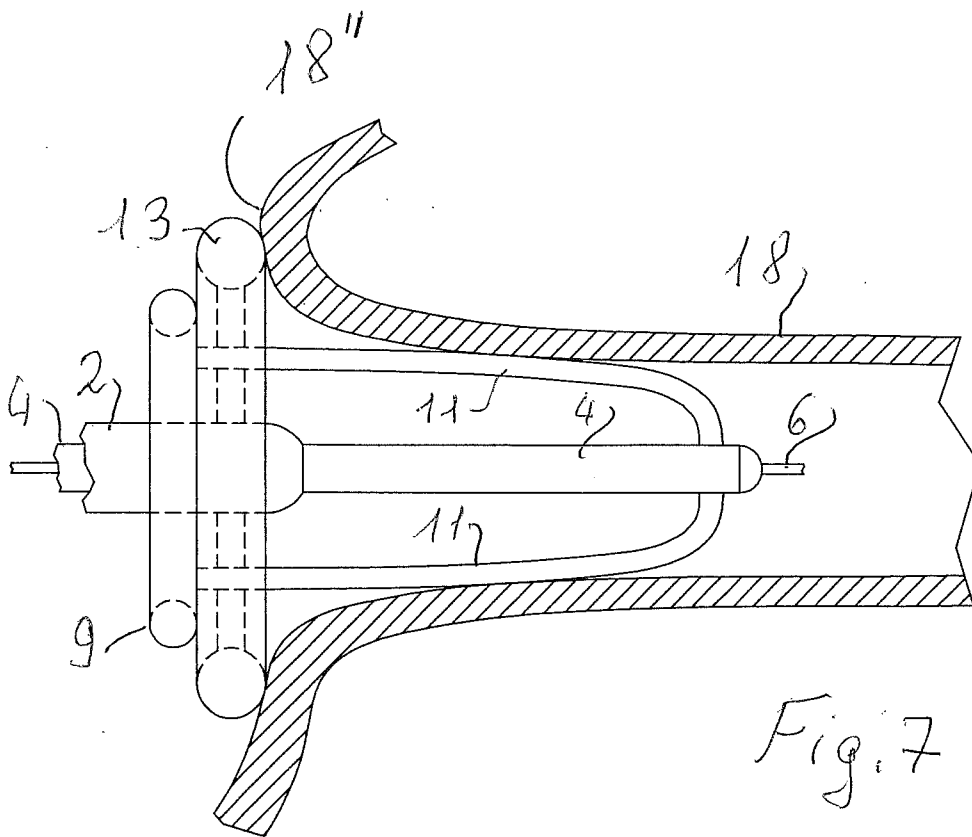

Fig. 7

INTERNATIONAL SEARCH REPORT

International application No  
PCT/EP2012/056626

A. CLASSIFICATION OF SUBJECT MATTER  
INV. A61B18/14  
ADD.  
According to International Patent Classification (IPC) or to both national classification and IPC

B. FIELDS SEARCHED  
Minimum documentation searched (classification system followed by classification symbols)  
A61B  
Documentation searched other than minimum documentation to the extent that such documents are included in the fields searched

Electronic data base consulted during the international search (name of data base and, where practicable, search terms used)  
EPO-Internal, WPI Data

C. DOCUMENTS CONSIDERED TO BE RELEVANT		
Category*	Citation of document, with indication, where appropriate, of the relevant passages	Relevant to claim No.
A	US 2006/224153 A1 (FISCHELL ROBERT E [US] ET AL) 5 October 2006 (2006-10-05) abstract; figures 1-4 paragraphs [0004], [0037] - [0040], [0046] -----	1-11
A	US 6 652 515 B1 (MAGUIRE MARK A [US] ET AL) 25 November 2003 (2003-11-25) the whole document -----	1-11
A	US 2005/165391 A1 (MAGUIRE MARK A [US] ET AL) 28 July 2005 (2005-07-28) cited in the application the whole document -----	1-11
A	US 2006/271032 A1 (CHIN ALBERT K [US] ET AL) 30 November 2006 (2006-11-30) the whole document -----	1-11
	-/--	

Further documents are listed in the continuation of Box C.

See patent family annex.

\* Special categories of cited documents :

- "A" document defining the general state of the art which is not considered to be of particular relevance
- "E" earlier application or patent but published on or after the international filing date
- "L" document which may throw doubts on priority claim(s) or which is cited to establish the publication date of another citation or other special reason (as specified)
- "O" document referring to an oral disclosure, use, exhibition or other means
- "P" document published prior to the international filing date but later than the priority date claimed

- "T" later document published after the international filing date or priority date and not in conflict with the application but cited to understand the principle or theory underlying the invention
- "X" document of particular relevance; the claimed invention cannot be considered novel or cannot be considered to involve an inventive step when the document is taken alone
- "Y" document of particular relevance; the claimed invention cannot be considered to involve an inventive step when the document is combined with one or more other such documents, such combination being obvious to a person skilled in the art
- "&" document member of the same patent family

Date of the actual completion of the international search  24 May 2012	Date of mailing of the international search report  05/06/2012
--	--

Name and mailing address of the ISA/ European Patent Office, P.B. 5818 Patentlaan 2 NL - 2280 HV Rijswijk Tel. (+31-70) 340-2040, Fax: (+31-70) 340-3016	Authorized officer  Pereda Cubián, David
--	--

## INTERNATIONAL SEARCH REPORT

International application No  
PCT/EP2012/056626

C(Continuation). DOCUMENTS CONSIDERED TO BE RELEVANT		
Category*	Citation of document, with indication, where appropriate, of the relevant passages	Relevant to claim No.
A	US 2005/234437 A1 (BAXTER LINCOLN S [US] ET AL) 20 October 2005 (2005-10-20) the whole document -----	1-11
A	US 2007/083195 A1 (WERNETH RANDELL L [US] ET AL) 12 April 2007 (2007-04-12) the whole document -----	1-11
A	US 2005/234436 A1 (BAXTER LINCOLN S [US] ET AL) 20 October 2005 (2005-10-20) the whole document -----	1-11
A	US 2007/066878 A1 (WORLEY SETH J [US] ET AL) 22 March 2007 (2007-03-22) the whole document -----	1-11
A	US 3 874 388 A (KING TERRY D ET AL) 1 April 1975 (1975-04-01) the whole document -----	1-11

# INTERNATIONAL SEARCH REPORT

Information on patent family members

International application No PCT/EP2012/056626
---

Patent document cited in search report	Publication date	Patent family member(s)	Publication date
US 2006224153	A1	05-10-2006	NONE
-----			
US 6652515	B1	25-11-2003	US 6652515 B1 25-11-2003
			US 2003125726 A1 03-07-2003
			US 2006084966 A1 20-04-2006
-----			
US 2005165391	A1	28-07-2005	NONE
-----			
US 2006271032	A1	30-11-2006	US 2006271032 A1 30-11-2006
			WO 2006127241 A2 30-11-2006
-----			
US 2005234437	A1	20-10-2005	US 2005234437 A1 20-10-2005
			US 2009275934 A1 05-11-2009
-----			
US 2007083195	A1	12-04-2007	AU 2006268238 A1 18-01-2007
			CA 2615267 A1 18-01-2007
			EP 1909679 A2 16-04-2008
			US 2007083195 A1 12-04-2007
			US 2009182325 A1 16-07-2009
			WO 2007008954 A2 18-01-2007
-----			
US 2005234436	A1	20-10-2005	NONE
-----			
US 2007066878	A1	22-03-2007	AU 2006292457 A1 29-03-2007
			CA 2622742 A1 29-03-2007
			CN 101304778 A 12-11-2008
			EP 1933922 A1 25-06-2008
			JP 4877847 B2 15-02-2012
			JP 2009508589 A 05-03-2009
			US 2007066878 A1 22-03-2007
			US 2010069734 A1 18-03-2010
			WO 2007035554 A1 29-03-2007
-----			
US 3874388	A	01-04-1975	AU 489252 B2 23-10-1976
			DE 2514142 A1 14-10-1976
			FR 2305165 A1 22-10-1976
			GB 1509023 A 26-04-1978
			US 3874388 A 01-04-1975
-----			