

(19) World Intellectual Property Organization
International Bureau



(43) International Publication Date
25 January 2001 (25.01.2001)

PCT

(10) International Publication Number
WO 01/06751 A1

(51) International Patent Classification⁷: H04M 11/06, H04L 12/28

(21) International Application Number: PCT/IL00/00128

(22) International Filing Date: 2 March 2000 (02.03.2000)

(25) Filing Language: English

(26) Publication Language: English

(30) Priority Data:
09/357,379 20 July 1999 (20.07.1999) US

(71) Applicant (for all designated States except US): SERCONET LTD. [IL/IL]; 16 Ha'Haroshet Street, P.O. Box 2009, 43657 Raanana (IL).

(72) Inventor; and

(75) Inventor/Applicant (for US only): BINDER, Yehuda [IL/IL]; 30 Yeshurun Street, 45200 Hod Hasharon (IL).

(74) Agent: REINHOLD COHN AND PARTNERS; P.O. Box 4060, 61040 Tel Aviv (IL).

(81) Designated States (national): AE, AL, AM, AT, AU, AZ, BA, BB, BG, BR, BY, CA, CH, CN, CR, CU, CZ, DE, DK, DM, EE, ES, FI, GB, GD, GE, GH, GM, HR, HU, ID, IL, IN, IS, JP, KE, KG, KP, KR, KZ, LC, LK, LR, LS, LT, LU, LV, MA, MD, MG, MK, MN, MW, MX, NO, NZ, PL, PT, RO, RU, SD, SE, SG, SI, SK, SL, TJ, TM, TR, TT, TZ, UA, UG, US, UZ, VN, YU, ZA, ZW.

(84) Designated States (regional): ARIPO patent (GH, GM, KE, LS, MW, SD, SL, SZ, TZ, UG, ZW), Eurasian patent (AM, AZ, BY, KG, KZ, MD, RU, TJ, TM), European patent (AT, BE, CH, CY, DE, DK, ES, FI, FR, GB, GR, IE, IT, LU, MC, NL, PT, SE), OAPI patent (BF, BJ, CF, CG, CI, CM, GA, GN, GW, ML, MR, NE, SN, TD, TG).

Published:

— With international search report.

For two-letter codes and other abbreviations, refer to the "Guidance Notes on Codes and Abbreviations" appearing at the beginning of each regular issue of the PCT Gazette.

(54) Title: NETWORK FOR TELEPHONY AND DATA COMMUNICATION

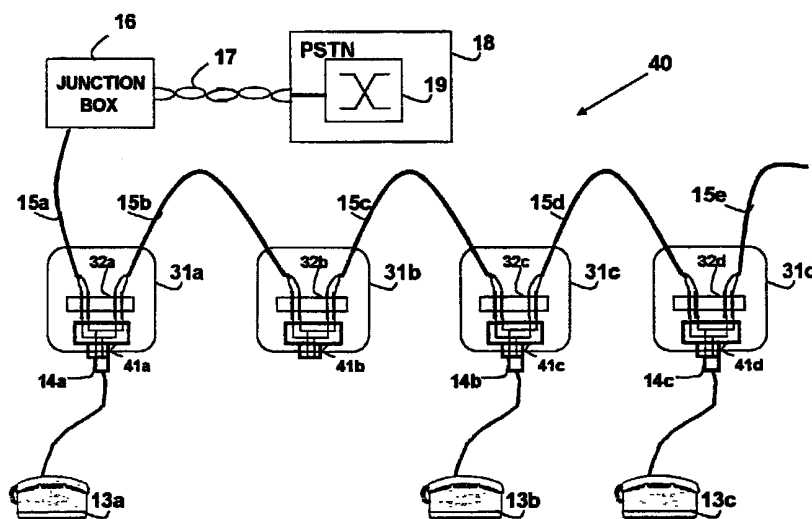

(57) Abstract: A local area network using the telephone wiring within a residence or other building simultaneously with telephony signals. The local area network uses high pass filters to access the high-frequency band across the media, whereas the standard telephone service uses low pass filters to access the low-frequency voice / analog telephony band across the same media. The electrically-conducting media connecting telephone / data outlets are split, or separated at each outlet, and the outlets are modified to provide access to both ends of the resulting segments. The low pass filters at each segment end join the segments together, allowing analog telephony signals to travel throughout the network, thus supporting normal telephone service. The high pass filters at each segment end are connected to modems or other Data Communication Equipment, thus supporting data communication networks of various topologies, including point-to-point topologies.



WO 01/06751 A1

- 1 -

Network for telephony and data communication

FIELD OF THE INVENTION

The present invention relates to the field of wired communication systems, and, more specifically, to the networking of devices using telephone lines.

5

BACKGROUND OF THE INVENTION

Figure 1 shows the wiring configuration for a prior-art telephone system **10** for a residence or other building, wired with a telephone line **5**. Residence telephone line **5** consists of single wire pair which connects to a junction-box **16**, which in turn connects to a Public Switched Telephone Network (PSTN) **18** via a cable **17**, terminating in a public switch **19**, apparatus which establishes and enables telephony from one telephone to another. The term "analog telephony" herein denotes traditional analog low-frequency audio voice signals typically under 3KHz, sometimes referred to as "POTS" ("plain old telephone service"), whereas the term
15 "telephony" in general denotes any kind of telephone service, including digital service such as Integrated Services Digital Network (ISDN). The term "high-frequency" herein denotes any frequency substantially above such analog telephony audio frequencies, such as that used for data. ISDN
20 typically uses frequencies not exceeding 100KHz (typically the energy is concentrated around 40KHz). The term "telephone device" herein denotes, without limitation, any apparatus for telephony (including both analog telephony and ISDN), as well as any device using telephony signals, such as fax, voice-modem, and so forth.

- 2 -

Junction box **16** is used to separate the in-home circuitry from the PSTN and is used as a test facility for troubleshooting as well as for wiring new telephone outlets in the home. A plurality of telephones **13a**, **13b**, and **13c** connects to telephone line **5** via a plurality of outlets **11a**, **11b**, **11c**, and **11d**. Each outlet has a connector (often referred to as a "jack"), denoted in Figure 1 as **12a**, **12b**, **12c**, and **12d**, respectively. Each outlet may be connected to a telephone via a connector (often referred to as a "plug"), denoted in Figure 1 (for the three telephone illustrated) as **14a**, **14b**, and **14c**, respectively. It is also important to note that lines **5a**, **5b**, **5c**, **5d**, and **5e** are electrically the same paired conductors.

There is a requirement for using the existing telephone infrastructure for both telephone and data networking. This would simplify the task of establishing a new local area network in a home or other building, because there would be no additional wires and outlets to install. U.S. Patent 4,766,402 to Crane (hereinafter referred to as "Crane") teaches a way to form a LAN over two wire telephone lines, but without the telephone service.

The concept of frequency domain / division multiplexing (FDM) is well-known in the art, and provides a means of splitting the bandwidth carried by a wire into a low-frequency band capable of carrying an analog telephony signal and a high-frequency band capable of carrying data communication or other signals. Such a mechanism is described for example in U.S. Patent 4,785,448 to Reichert et al (hereinafter referred to as "Reichert"). Also is widely used are xDSL systems, primarily Asymmetric Digital Subscriber Loop (ADSL) systems.

Relevant prior art in this field is also disclosed in U.S. Patent 5,896,443 to Dichter (hereinafter referred to as "Dichter"). Dichter is the first to suggest a method and apparatus for applying such a technique for residence telephone wiring, enabling simultaneously carrying telephone and

- 3 -

data communication signals. The Dichter network is illustrated in Figure 2, which shows a network **20** serving both telephones and a local area network. Data Terminal Equipment (DTE) units **24a**, **24b** and **24c** are connected to the local area network via Data Communication Equipment (DCE) units **23a**, **23b** and **23c**, respectively. Examples of Data Communication Equipment include modems, line drivers, line receivers, and transceivers. DCE units **23a**, **23b** and **23c** are respectively connected to high pass filters (HPF) **22a**, **22b** and **22c**. The HPF's allow the DCE units access to the high-frequency band carried by telephone line **5**. In a first embodiment (not shown in Figure 2), telephones **13a**, **13b** and **13c** are directly connected to telephone line **5** via connectors **14a**, **14b** and **14c**, respectively. However, in order to avoid interference to the data network caused by the telephones, a second embodiment is suggested (shown in Figure 2), wherein low pass filters (LPF's) **21a**, **21b** and **21c** are added to isolate telephones **13a**, **13b** and **13c** from telephone line **5**. Furthermore, a low pass filter must also be connected to Junction-Box **16**, in order to filter noises induced from or to the PSTN wiring **17**. As is the case in Figure 1, it is important to note that lines **5a**, **5b**, **5c**, **5d** and **5e** are electrically the same paired conductors.

The Dichter network suffers from degraded data communication performance, because of the following drawbacks:

1. Induced noise in the band used by the data communication network is distributed throughout the network. The telephone line within a building serves as a long antenna, receiving electromagnetic noise produced from outside the building or by local equipment such as air-conditioning systems, appliances, and so forth. Electrical noise in the frequency band used by the data communication network can be induced in the extremities of the telephone line **5** (line **5e** or **5a** in Figure 2) and propagated via the

- 4 -

telephone line **5** throughout the whole system. This is liable to cause errors in the data transportation.

2. The wiring media consists of a single long wire (telephone line **5**). In order to ensure a proper impedance match to this transmission-line, it is necessary to install terminators at each end of the telephone line **5**. One of the advantages of using the telephone infrastructure for a data network, however, is to avoid replacing the internal wiring. Thus, either such terminators must be installed at additional cost, or suffer the performance problems associated with an impedance mismatch.
3. In the case where LPF **21** is not fitted to the telephones **13**, each connected telephone appears as a non-terminated stub, and this is liable to cause undesirable signal reflections.
4. In one embodiment, an LPF **21** is to be attached to each telephone **13**. In such a configuration, an additional modification to the telephone itself is required. This further makes the implementation of such system complex and costly, and defeats the purpose of using an existing telephone line and telephone sets 'as is' for a data network.
5. The data communication network used in the Dichter network supports only the 'bus' type of data communication network, wherein all devices share the same physical media. Such topology suffers from a number of drawbacks, as described in U.S. Patent 5,841,360 to the present inventor, which is incorporated by reference for all purposes as if fully set forth herein. Dichter also discloses drawbacks of the bus topology, including the need for bus mastering and logic to contend with the data packet collision problem. Topologies that are preferable to the bus topology include the Token-Ring (IEEE 803), the PSIC

- 5 -

network according to U.S. Patent 5,841,360, and other point-to-point networks known in the art (such as a serial point-to-point 'daisy chain' network). Such networks are in most cases superior to 'bus' topology systems.

5 The above drawbacks affect the data communication performance of the Dichter network, and therefore limit the total distance and the maximum data rate such a network can support. In addition, the Dichter network typically requires a complex and therefore costly transceiver to support the data communication system. While the Reichert network relies on a star
10 topology and does not suffer from these drawbacks of the bus topology, the star topology also has disadvantages. First, the star topology requires a complex and costly hub module, whose capacity limits the capacity of the network. Furthermore, the star configuration requires that there exist wiring from every device on the network to a central location, where the hub
15 module is situated. This may be impractical and/or expensive to achieve, especially in the case where the wiring of an existing telephone system is to be utilized. The Reichert network is intended for use only in offices where a central telephone connection point already exists. Moreover, the Reichert network requires a separate telephone line for each separate telephone
20 device, and this, too, may be impractical and/or expensive to achieve.

 There is thus a widely-recognized need for, and it would be highly advantageous to have, a means for implementing a data communication network using existing telephone lines of arbitrary topology, which continues to support analog telephony while also allowing for improved
25 communication characteristics by supporting a point-to-point topology network.

SUMMARY OF THE INVENTION

The present invention provides a method and apparatus for using the telephone line wiring system within residence or other building for both analog telephony service and a local area data network featuring a serial "daisy chained" or other arbitrary topology. First, the regular outlets are modified or substituted to allow splitting of the telephone line having two wires into segments such that each segment connecting two outlets is fully separated from all other segments. Each segment has two ends, to which various devices, other segments, and so forth, may be connected. A low pass filter is connected in series to each end of the segment, thereby forming a low-frequency path between the external ports of the low pass filters, utilizing the low-frequency band. Similarly, a high pass filter is connected in series to each end of the segment, thereby forming a high-frequency path between the external ports of the high pass filters, utilizing the high-frequency band. The bandwidth carried by the segments is thereby split into non-overlapping frequency bands, and the distinct paths can be interconnected via the high pass filters and low pass filters as coupling and isolating devices to form different paths. Depending on how the devices and paths are selectively connected, these paths may be simultaneously different for different frequencies. A low-frequency band is allocated to regular telephone service (analog telephony), while a high-frequency band is allocated to the data communication network. In the low-frequency (analog telephony) band, the wiring composed of the coupled low-frequency paths appears as a normal telephone line, in such a way that the low-frequency (analog telephony) band is coupled among all the segments and is accessible to telephone devices at any outlet, whereas the segments may remain individually isolated in the high-frequency (data) band, so that in this data band the communication media, if desired, can

appear to be point-to-point (such as a serialized "daisy chain") from one outlet to the next. The term "low pass filter" herein denotes any device that passes signals in the low-frequency (analog telephony) band but blocks signals in the high-frequency (data) band. Conversely, the term "high pass filter" herein denotes any device that passes signals in the high-frequency (data) band but blocks signals in the low-frequency (analog telephony) band. The term "data device" herein denotes any apparatus that handles digital data, including without limitation modems, transceivers, Data Communication Equipment, and Data Terminal Equipment.

10 A network according to the present invention allows the telephone devices to be connected as in a normal telephone installation (i.e., in parallel over the telephone lines), but can be configured to virtually any desired topology for data transport and distribution, as determined by the available existing telephone line wiring and without being constrained to
15 any predetermined data network topology. Moreover, such a network offers the potential for the improved data transport and distribution performance of a point-to-point network topology, while still allowing a bus-type data network topology in all or part of the network if desired. This is in contrast to the prior art, which constrains the network topology to a predetermined
20 type.

A network according to the present invention may be used advantageously when connected to external systems and networks, such as xDSL, ADSL, as well as the Internet.

In a first embodiment, the high pass filters are connected in such a way to create a virtual 'bus' topology for the high-frequency band, allowing
25 for a local area network based on DCE units or transceivers connected to the segments via the high pass filters. In a second embodiment, each segment end is connected to a dedicated modem, hence offering a serial point-to-point daisy chain network. In all embodiments of the present

- 8 -

invention, DTE units or other devices connected to the DCE units can communicate over the telephone line without interfering with, or being affected by, simultaneous analog telephony service. Unlike prior-art networks, the topology of a network according to the present invention is not constrained to a particular network topology determined in advance, but can be adapted to the configuration of an existing telephone line installation. Moreover, embodiments of the present invention that feature point-to-point data network topologies exhibit the superior performance characteristics that such topologies offer over the bus network topologies of the prior art, such as the Dichter network and the Crane network.

Therefore, according to the present invention there is provided a network for telephony and data communication including: (a) at least one electrically-conductive segment containing at least two distinct electrical conductors operative to conducting a low-frequency telephony band and at least one high-frequency data band, each of the segments having a respective first end and a respective second end; (b) a first low pass filter connected in series to the respective first end of each of the segments, for establishing a low-frequency path for the low-frequency telephony band; (c) a second low pass filter connected in series to the respective second end of each of the segments, for establishing a low-frequency path for the low-frequency telephony band; (d) a first high pass filter connected in series to the respective first end of each of the segments, for establishing a high-frequency path for the at least one high-frequency data band; (e) a second high pass filter connected in series to the respective second end of each of the segments, for establishing a high-frequency path for the at least one high-frequency data band; and (f) at least two outlets each operative to connecting at least one telephone device to at least one of the low-frequency paths, and at least two of the at least two outlets being operative to connecting at least one data device to at least one of the

– 9 –

high-frequency paths: wherein each of the segments electrically connects two of the outlets: and each of the outlets that is connected to more than one of the segments couples the low-frequency telephony band among each of the connected segments.

5

BRIEF DESCRIPTION OF THE DRAWINGS

In order to understand the invention and to see how the same may be carried out in practice, some preferred embodiments will now be described, by way of non-limiting example only, with reference to the accompanying drawings, wherein:

10

Figure 1 shows a common prior art telephone line wiring configuration for a residence or other building.

Figure 2 shows a prior art local area network based on telephone line wiring for a residence or other building.

15

Figure 3 shows modifications to telephone line wiring according to the present invention for a local area network.

Figure 4 shows modifications to telephone line wiring according to the present invention, to support regular telephone service operation.

Figure 5 shows a splitter according to the present invention.

20

Figure 6 shows a local area network based on telephone lines according to the present invention, wherein the network supports two devices at adjacent outlets.

Figure 7 shows a first embodiment of a local area network based on telephone lines according to the present invention, wherein the network supports two devices at non-adjacent outlets.

25

Figure 8 shows a second embodiment of a local area network based on telephone lines according to the present invention, wherein the network supports three devices at adjacent outlets.

- 10 -

Figure 9 shows third embodiment of a local area network based on telephone lines according to the present invention, wherein the network is a bus type network.

Figure 10 shows a node of local area network based on telephone lines according to the present invention.

Figure 11 shows a fourth embodiment of a local area network based on telephone lines according to the present invention.

DESCRIPTION OF THE PREFERRED EMBODIMENTS

The principles and operation of a network according to the present invention may be understood with reference to the drawings and the accompanying description. The drawings and descriptions are conceptual only. In actual practice, a single component can implement one or more functions; alternatively, each function can be implemented by a plurality of components and circuits. In the drawings and descriptions, identical reference numerals indicate those components which are common to different embodiments or configurations.

The basic concept of the invention is shown in Figure 3. A network **30** is based on modified telephone outlets **31a**, **31b**, **31c** and **31d**. The modification relates to wiring changes at the outlets and substituting the telephone connectors, shown as connectors **32a**, **32b**, **32c** and **32d** in outlets **31a**, **31b**, **31c** and **31d** respectively. No changes are required in the overall telephone line layout or configuration. The wiring is changed by separating the wires at each outlet into distinct segments of electrically-conducting media. Thus, each segment connecting two outlets can be individually accessed from either end. In the prior art Dichter network, the telephone wiring is not changed, and is continuously conductive from junction box **16** throughout the system. According to the present invention, the telephone line is broken into electrically distinct isolated segments **15a**, **15b**, **15c**, **15d**

- 11 -

and **15e**, each of which connects two outlets. In order to fully access the media, each of connectors **32a**, **32b**, **32c** and **32d** must support four connections, two in each segment. This modification to the telephone line can be carried out by replacing each of the outlets **31a**, **31b**, **31c** and **31d**,
5 replacing only the connectors **32a**, **32b**, **32c** and **32d**, or simply by cutting the telephone line wiring at the outlet. As will be explained later, these modifications need be performed only to those outlets which connect to data network devices, but are recommended at all other outlets. A minimum of two outlets must be modified, enabling data communication between
10 those outlets only.

Figure 4 shows how a network **40** of the present invention continues to support the regular telephone service, by the installation of jumpers **41a**, **41b**, **41c** and **41d** in modified outlets **31a**, **31b**, **31c** and **31d** respectively. At each outlet where they are installed, the jumpers connect both segment
15 ends and allow telephone connection to the combined segment. Installation of a jumper effects a re-connection of the split telephone line at the point of installation. Installation of jumpers at all outlets would reconstruct the prior art telephone line configuration as shown in Figure 1. Such jumpers can be add-ons to the outlets, integrated within the outlets, or integrated into a
20 separate module. Alternately, a jumper can be integrated within a telephone set, as part of connector **14**. The term "jumper" herein denotes any device for selectively coupling or isolating the distinct segments in a way that is not specific to the frequency band of the coupled or isolated signals. Jumper **41** can be implemented with a simple electrical connection between the
25 connection points of connector **32** and the external connection of the telephone.

As described above, jumpers **41** are to be installed in all outlets which are not required for connection to the data communication network. Those outlets which are required to support data communication

- 12 -

connections, however, will not use jumper **41** but rather a splitter **50**, shown in Figure 5. Such a splitter connects to both segments in each modified outlet **31** via connector **32**, using a port **54** for a first connection and a port **55** for a second connection. Splitter **50** has two LPF's for maintaining the continuity of the audio / telephone low-frequency band. After low pass filtering by LPF **51a** for the port **54** and LPF **51b** for port **55**, the analog telephony signals are connected together and connected to a telephone connector **53**. Hence, from the point of view of the telephone signal, the splitter **50** provides the same continuity and telephone access provided by the jumper **41**. On the other hand, the data communication network employs the high-frequency band, access to which is made via HPF's **52a** and **52b**. HPF **52a** is connected to port **54** and HPF **52b** is connected to port **55**. The high pass filtered signals are not passed from port **54** to port **55**, but are kept separate, and are routed to a connector **56** and a connector **57**, respectively. The term "splitter" herein denotes any device for selectively coupling or isolating the distinct segments that is specific to the frequency band of the coupled or isolated signals.

Therefore, when installed in an outlet, the splitter **50** serves two functions. With respect to the low-frequency analog telephony band, splitter **50** establishes a coupling to effect the prior-art configuration shown in Figure 1, wherein all telephone devices in the premises are connected virtually in parallel via the telephone line, as if the telephone line were not broken into segments. On the other hand, with respect to the high-frequency data communication network, splitter **50** establishes electrical isolation to effect the configuration shown in Figure 3, wherein the segments are separated, and access to each segment end is provided by the outlets. With the use of splitters, the telephone system and the data communication network are actually decoupled, with each supporting a different topology.

– 13 –

Figure 6 shows a first embodiment of a data communication network **60** between two DTE units **24a** and **24b**, connected to adjacent outlets **31b** and **31c**, which are connected together via a single segment **15c**. Splitters **50a** and **50b** are connected to outlets **31b** and **31c** via connectors **32b** and **32c**, respectively. As explained above, the splitters allow transparent audio / telephone signal connection. Thus, for analog telephony, the telephone line remains virtually unchanged, allowing access to telephone external connection **17** via junction box **16** for telephones **13a** and **13c**. Likewise, telephone **13b** connected via connector **14b** to a connector **53a** on splitter **50a**, is also connected to the telephone line. In a similar way, an additional telephone can be added to outlet **31c** by connecting the telephone to connector **53b** on splitter **50b**. It should be clear that connecting a telephone to an outlet, either via jumper **41** or via splitter **50** does not affect the data communication network.

Network **60** (Figure 6) supports data communication by providing a communication path between port **57a** of splitter **50a** and port **56b** of splitter **50b**. Between these ports there exists a point-to-point connection for the high-frequency portion of the signal spectrum, as determined by HPF **52a** and **52b** within splitters **50** (Figure 5). This path can be used to establish a communication link between DTE units **24a** and **24b**, by means of DCE units **23a** and **23b**, which are respectively connected to ports **57a** and **56b**. The communication between DTE units **24a** and **24b** can be unidirectional, half-duplex, or full-duplex. The only limitation imposed on the communication system is the capability to use the high-frequency portion of the spectrum of segment **15c**. As an example, the implementation of data transmission over a telephone line point-to-point system described in Reichert can also be used in network **60**. Reichert implements both LPF and HPF by means of a transformer with a capacitor connected in the

- 14 -

center-tap, as is well known in the art. Similarly, splitter **50** can be easily implemented by two such circuits, one for each side.

It should also be apparent that HPF **52a** in splitter **50a** and HPF **52b** in splitter **50b** can be omitted, because neither port **56a** in splitter **50a** nor
5 port **57b** in splitter **50b** is connected.

Network **60** provides clear advantages over the networks described in hitherto-proposed networks. First, the communication media supports point-to-point connections, which are known to be superior to multi-tap (bus) connections for communication performance. In addition, terminators
10 can be used within each splitter or DCE unit, providing a superior match to the transmission line characteristics. Furthermore, no taps (drops) exists in the media, thereby avoiding impedance matching problems and the reflections that result therefrom.

Moreover, the data communication system in network **60** is isolated
15 from noises from both the network and the 'left' part of the telephone network (Segments **15a** and **15b**), as well as noises induced from the 'right' portion of the network (Segments **15d** and **15e**). Such isolation is not provided in any prior-art implementation. Dichter suggests installation of a low pass filter in the junction box, which is not a satisfactory solution since
20 the junction box is usually owned by the telephone service provider and cannot always be accessed. Furthermore, safety issues such as isolation, lightning protection, power-cross and other issues are involved in such a modification.

Implementing splitter **50** by passive components only, such as two
25 transformers and two center-tap capacitors, is also advantageous, since the reliability of the telephone service will not be degraded, even in the case of failure in any DCE unit, and furthermore requires no external power. This accommodates a 'life-line' function, which provides for continuous

– 15 –

telephone service even in the event of other system malfunction (e.g. electrical failures).

The splitter **50** can be integrated into outlet **31**. In such a case, outlets equipped with splitter **50** will have two types of connectors: One regular telephone connector based on port **53**, and one or two connectors providing
5 access to ports **56** and **57** (a single quadruple-circuit connector or two double-circuit connectors). Alternatively, splitter **50** can be an independent module attached as an add-on to outlet **31**. In another embodiment, the splitter is included as part of DCE **23**. However, in order for network **60** to
10 operate properly, either jumper **41** or splitter **50** must be employed in outlet **31** as modified in order to split connector **32** according to the present invention, allowing the retaining of regular telephone service.

Figure 7 also shows data communication between two DTE units **24a** and **24b** in a network **70**. However, in the case of network **70**, DTE
15 units **24a** and **24b** are located at outlets **31b** and **31d**, which are not directly connected, but have an additional outlet **31c** interposed therebetween. Outlet **31c** is connected to outlet **31b** via a segment **15c**, and to outlet **31d** via a segment **15d**.

In one embodiment of network **70**, a jumper (not shown, but similar
20 to jumper **41** in Figure 4) is connected to a connector **32c** in outlet **31c**. The previous discussion regarding the splitting of the signal spectrum also applies here, and allows for data transport between DTE units **24a** and **24b** via the high-frequency portion of the spectrum across segments **15c** and **15d**. When only jumper **41** is connected at outlet **31c**, the same
25 point-to-point performance as previously discussed can be expected; the only influence on communication performance is from the addition of segment **15d**, which extends the length of the media and hence leads to increased signal attenuation. Some degradation, however, can also be expected when a telephone is connected to jumper **41** at outlet **31c**. Such

– 16 –

degradation can be the result of noise produced by the telephone in the high-frequency data communication band, as well as the result of the addition of a tap caused by the telephone connection, which usually has a non-matched termination. Those problems can be overcome by installing a
5 low pass filter in the telephone.

In a preferred embodiment of network **70**, a splitter **50b** is installed in outlet **31c**. Splitter **50b** provides the LPF functionality, and allows for connecting a telephone via connector **53b**. However, in order to allow for continuity in data communication, there must be a connection between the
10 circuits in connectors **56b** and **57b**. Such a connection is obtained by a jumper **71**, as shown in Figure 7. Installation of splitter **50b** and jumper **71** provides good communication performance, similar to network **60** (Figure 6). From this discussion of a system wherein there is only one unused outlet between the outlets to which the DTE units are connected, it should be clear
15 that the any number of unused outlets between the outlets to which the DTE units are connected can be handled in the same manner.

For the purpose of the foregoing discussions, only two communicating DTE units have been described. However, the present invention can be easily applied to any number of DTE units. Figure 8
20 illustrates a network **80** supporting three DTE units **24a**, **24b** and **24c**, connected thereto via DCE units **23a**, **23b** and **23c**, respectively. The structure of network **80** is the same as that of network **70** (Figure 7), with the exception of the substitution of jumper **71** with a jumper **81**. Jumper **81** makes a connection between ports **56b** and **57b** in the same way as does
25 jumper **71**. However, in a manner similar to that of jumper **41** (Figure 4), jumper **81** further allows for an external connection to the joined circuits, allowing the connection of external unit, such as a DCE unit **23c**. In this way, segments **15c** and **15d** appear electrically-connected for high-frequency signals, and constitute media for a data communication network

– 17 –

connecting DTE units **24a**, **24b** and **24c**. Obviously, this configuration can be adapted to any number of outlets and DTE units. In fact, any data communication network which supports a 'bus' or multi-point connection over two-conductor media, and which also makes use of the higher-frequency part of the spectrum can be used. In addition, the discussion and techniques explained in the Dichter patent are equally applicable here. Some networks, such as Ethernet IEEE 802.3 interface 10BaseT and 100BaseTX, require a four-conductor connection, two conductors (usually single twisted-wire pair) for transmitting, and two conductors (usually another twisted-wire pair) for receiving. As is known in the art, a four-to-two wires converter (commonly known as hybrid) can be used to convert the four wires required into two, thereby allowing network data transport over telephone lines according to the present invention.

As with jumper **41** (Figure 4), jumper **81** can be an integral part of splitter **50**, an integral part of DCE **23**, or a separate component.

In order to simplify the installation and operation of a network, it is beneficial to use the same equipment in all parts of the network. One such embodiment supporting this approach is shown in for a set of three similar outlets in Figure 8, illustrating network **80**. In network **80**, outlets **31b**, **31c**, and **31d** are similar and are all used as part of the data communication network. Therefore for uniformity, these outlets are all coupled to splitters **50a**, **50b**, and **50c** respectively, to which jumpers are attached, such as a jumper **81** attached to splitter **50b** (the corresponding jumpers attached to splitter **50a** and splitter **50c** have been omitted from Figure 8 for clarity), and thus provide connections to local DCE units **23a**, **23c**, and **23b**, respectively. In a preferred embodiment of the present invention, all outlets in the building will be modified to include both splitter **50** and jumper **81** functionalities. Each such outlet will provide two connectors: one connector

- 18 -

coupled to port **53** for a telephone connection, and the other connector coupled to jumper **81** for a DCE connection.

In yet another embodiment, DCE **23** and splitter **50** are integrated into the housing of outlet **31**, thereby offering a direct DTE connection. In a preferred embodiment, a standard DTE interface is employed.

In most 'bus' type networks, it is occasionally required to split the network into sections, and connect the sections via repeaters (to compensate for long cabling), via bridges (to decouple each section from the others), or via routers. This may also be done according to the present invention, as illustrated in Figure 9 for a network **90**, which employs a repeater / bridge / router unit **91**. Unit **91** can perform repeating, bridging, routing, or any other function associated with a split between two or more networks. As illustrated, a splitter **50b** is coupled to an outlet **31c**, in a manner similar to the other outlets and splitters of network **90**. However, at splitter **50b**, no jumper is employed. Instead, a repeater / bridge/ router unit **91** is connected between port **56b** and port **57b**, thereby providing a connection between separate parts of network **90**. Optionally, unit **91** can also provide an interface to DTE **24c** for access to network **90**.

Figure 9 also demonstrates the capability of connecting to external DTE units or networks, via a high pass filter **92** connected to a line **15a**. Alternatively, HPF **92** can be installed in junction box **16**. HPF **92** allows for additional external units to access network **90**. As shown in Figure 9, HPF **92** is coupled to a DCE unit **93**, which in turn is connected to a network **94**. In this configuration, the local data communication network in the building becomes part of network **94**. In one embodiment, network **94** offers ADSL service, thereby allowing the DTE units **24d**, **24a**, **24c** and **24b** within the building to communicate with the ADSL network. The capability of communicating with external DTE units or networks is equally

applicable to all other embodiments of the present invention, but for clarity is omitted from the other drawings.

While the foregoing relates to data communication networks employing bus topology, the present invention can also support networks where the physical layer is distinct within each communication link. Such a network can be a Token-Passing or Token-Ring network according to IEEE 802, or preferably a PSIC network as described in U.S. Patent 5,841,360 to the present inventor, which details the advantages of such a topology. Figure 10 illustrates a node **100** for implementing such a network. Node **100** employs two modems **103a** and **103b**, which handle the communication physical layer. Modems **103a** and **103b** are independent, and couple to dedicated communication links **104a** and **104b**, respectively. Node **100** also features a DTE interface **101** for connecting to a DTE unit (not shown). A control and logic unit **102** manages the higher OSI layers of the data communication above the physical layer, processing the data to and from a connected DTE and handling the network control. Detailed discussion about such node **100** and the functioning thereof can be found in U.S. Patent 5,841,360 and other sources known in the art.

Figure 11 describes a network **110** containing nodes **100d**, **100a**, **100b** and **100c** coupled directly to splitters **50d**, **50a**, **50b** and **50c**, which in turn are coupled to outlets **31a**, **31b**, **31c** and **31d** respectively. Each node **100** has access to the corresponding splitter **50** via two pairs of contacts, one of which is to connector **56** and the other of which is to connector **57**. In this way, for example, node **100a** has independent access to both segment **15b** and segment **15c**. This arrangement allows building a network connecting DTE units **24d**, **24a**, **24b** and **24c** via nodes **100d**, **100a**, **100b** and **100c**, respectively.

For clarity, telephones are omitted from Figures 9 and 11, but it will be clear that telephones can be connected or removed without affecting the

- 20 -

data communication network. Telephones can be connected as required via connectors **53** of splitters **50**. In general, according to the present invention, a telephone can be connected without any modifications either to a splitter **50** (as in Figure 8) or to a jumper **41** (as in Figure 4).

5 Furthermore, although the present invention has so far been described with a single DTE connected to a single outlet, multiple DTE units can be connected to an outlet, as long as the corresponding node or DCE supports the requisite number of connections. Moreover, access to the communication media can be available for plurality of users using
10 multiplexing techniques known in the art. In the case of time domain / division multiplexing (TDM) the whole bandwidth is dedicated to a specific user during a given time interval. In the case of frequency domain / division multiplexing (FDM), a number of users can share the media simultaneously, each using different non-overlapping portions of the
15 frequency spectrum.

 In addition to the described data communication purposes, a network according to the present invention can be used for control (e.g. home automation), sensing, audio, or video applications, and the communication can also utilize analog signals (herein denoted by the term "analog
20 communication"). For example, a video signal can be transmitted in analog form via the network.

 While the present invention has been described in terms of outlets which have only two connections and therefore can connect only to two other outlets (i.e., in a serial, or "daisy chain" configuration), the concept
25 can also be extended to three or more connections. In such a case, each additional connecting telephone line must be broken at the outlet, with connections made to the conductors thereof, in the same manner as has been described and illustrated for two segments. A splitter for such a multi-

segment application should use one low pass filter and one high pass filter for each segment connection.

The present invention has also been described in terms of media having a single pair of wires, but can also be applied for more conductors. For example, ISDN employs two pairs for communication. Each pair can be used individually for a data communication network as described above.

Also as explained above, an outlet **31** according to the invention (Figure 3) has a connector **32** having at least four connection points. As an option, jumper **41** (Figure 4), splitter **50** (Figure 5), or splitter **50** with jumper **81** (Figure 8), low pass filters, high pass filters, or other additional hardware may also be integrated or housed internally within outlet **31**. Alternatively, these devices may be external to the outlet. Moreover, the outlet may contain standard connectors for devices, such as DTE units. In one embodiment, only passive components are included within the outlet. For example, splitter **50** can have two transformers and two capacitors (or an alternative implementation consisting of passive components). In another embodiment, the outlet may contain active, power-consuming components. Three options can be used for providing power to such circuits:

1. Local powering: In this option, supply power is fed locally to each power-consuming outlet. Such outlets must be modified to support connection for input power.
2. Telephone power: In both POTS and ISDN telephone networks, power is carried in the lines with the telephone signals. This power can also be used for powering the outlet circuits, as long as the total power consumption does not exceed the POTS / ISDN system specifications. Furthermore, in some POTS systems the power consumption is used for OFF-HOOK/ON-HOOK signaling. In such a case, the network power consumption must not interfere with the telephone logic.

- 22 -

3. Dedicated power carried in the media: In this option, power for the data communication related components is carried in the communication media. For example, power can be distributed using 5 kHz signal. This frequency is beyond the telephone signal bandwidth, and thus does not interfere with the telephone service. The data communication bandwidth, however, be above this 5 kHz frequency, again ensuring that there is no interference between power and signals.

While the invention has been described with respect to a limited number of embodiments, it will be appreciated that many variations, modifications and other applications of the invention may be made.

CLAIMS:

1. A network for telephony and data communication comprising:

at least one electrically-conductive segment containing at least two distinct electrical conductors operative to conducting a low-frequency telephony band and at least one high-frequency data band, each of said segments having a respective first end and a respective second end:

a first low pass filter connected in series to the respective first end of each of said segments, for establishing a low-frequency path for said low-frequency telephony band:

10 a second low pass filter connected in series to the respective second end of each of said segments, for establishing a low-frequency path for said low-frequency telephony band:

a first high pass filter connected in series to the respective first end of each of said segments, for establishing a high-frequency path for said at least one high-frequency data band:

15 a second high pass filter connected in series to the respective second end of each of said segments, for establishing a high-frequency path for said at least one high-frequency data band: and

at least two outlets each operative to connecting at least one telephone device to at least one of said low-frequency paths, and at least two of said at least two outlets being operative to connecting at least one data device to at least one of said high-frequency paths:

wherein:

each of said paths electrically connects two of said outlets: and

25 each of said outlets that is coupled to more than one of said segments connects said low-frequency telephony paths among each of said coupled segments.

- 24 -

2. The network as in claim 1 wherein at least one of said segments is a telephone line.
3. The network as in claim 1 wherein the telephony is analog telephony.
- 5 4. The network as in claim 1 wherein:
the telephony is ISDN;
said segments contain at least four separate electrical conductors:
and
at least two of said distinct electrical conductors are operative to
10 carrying data.
5. The network as in claim 1, wherein at least one of said high-frequency band is operative to carrying analog communication.
6. The network as in claim 1, wherein at least one of said low pass filter is internal to one of said outlets.
- 15 7. The network as in claim 1, wherein at least one of said low pass filter is external to all of said outlets.
8. The network as in claim 1, wherein at least one of said high pass filter is internal to one of said outlets.
9. The network as in claim 1, wherein at least one of said
20 high-frequency is external to all of said outlets.
10. The network as in claim 1, comprising a plurality of said segments and at least three of said outlets.

– 25 –

11. The network as in claim 10, wherein said first low pass filter of a first segment is connected to said second low pass filter of a second segment.
12. The network as in claim 10, wherein said segments are connected
5 serially by said outlets.
13. The network as in claim 10, wherein said high-frequency data paths of all of said segments are coupled together.
14. The network as in claim 1, wherein said low pass filter comprises a center-tap transformer and a capacitor.
- 10 15. The network as in claim 1, wherein said high pass filter comprises a center-tap transformer and a capacitor.
16. The network as in claim 1, furthermore connected to an xDSL system.
17. The network as in claim 16, wherein said xDSL system is an ADSL
15 system.
18. The network as in claim 1, furthermore connected to the Internet.
19. An outlet for connecting devices to a telephone line for telephony and data communications, the telephone line having at least one electrically conductive segment containing at least two distinct electrical conductors
20 operative to conducting a low-frequency telephony band and a high-frequency data band, the outlet comprising:
- first connection means for connecting a first port of a low pass filter and a first port of a high pass filter to at least one end of the at least one segment;

– 26 –

second connection means for connecting at least one telephone device to a second port of said low pass filter: and

third connection means for connecting at least one data device to a second port of said high pass filter.

5 **20.** The outlet as in claim 19, wherein said low pass filter is housed internally therein.

21. The outlet as in claim 19, furthermore comprising at least part of at least one DCE unit housed internally therein.

10 **22.** The outlet as in claim 19, furthermore comprising a DTE unit housed internally therein.

23. The outlet as in claim 19, furthermore comprising a DTE standard connector.

24. The outlet as in claim 19, wherein said high pass filter is housed internally therein.

15 **25.** A splitter for a telephone line having at least two distinct segments, for coupling the segments in the low-frequency analog telephony band and isolating the segments in the high-frequency data band and for selectively connecting a data device to the high-frequency data band of at least one of the segments, each segment containing at least two separate electrical
20 conductors operative to conducting a low-frequency analog telephony band and a high-frequency data band, the splitter comprising:

at least one high pass filter connected in series with a segment for selectively connecting a data device to the high-frequency data band of one of the segments;

– 27 –

at least one low pass filter connected in series with a segment for coupling the segments in the low-frequency analog telephony band and isolating the segments in the high-frequency data band; and at least one connector for selectively connecting a data device to one of said high pass filters.

5

26. The splitter as in claim 25 furthermore comprising a connector for selectively connecting a telephone device to one of said low pass filters.

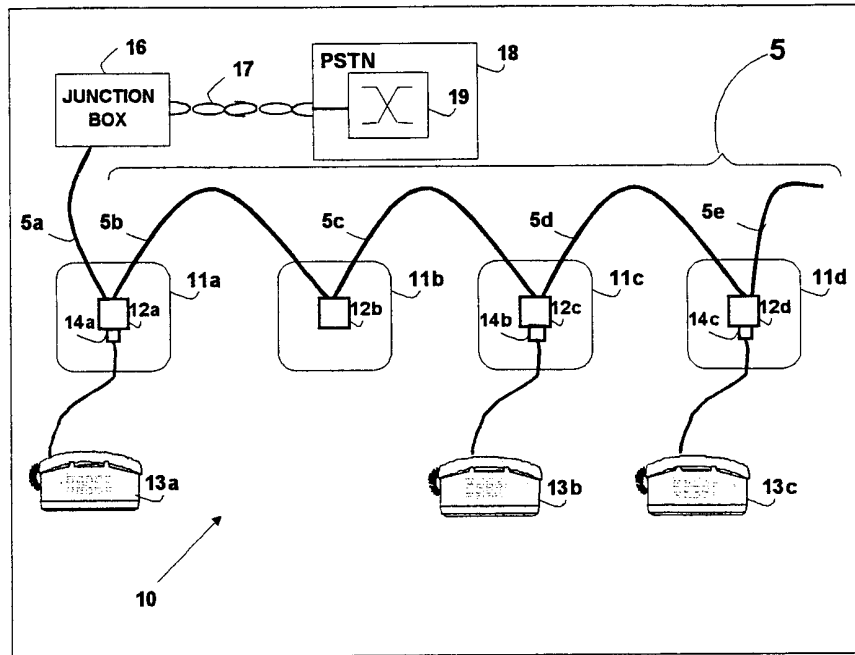

FIG. 1. (PRIOR ART)

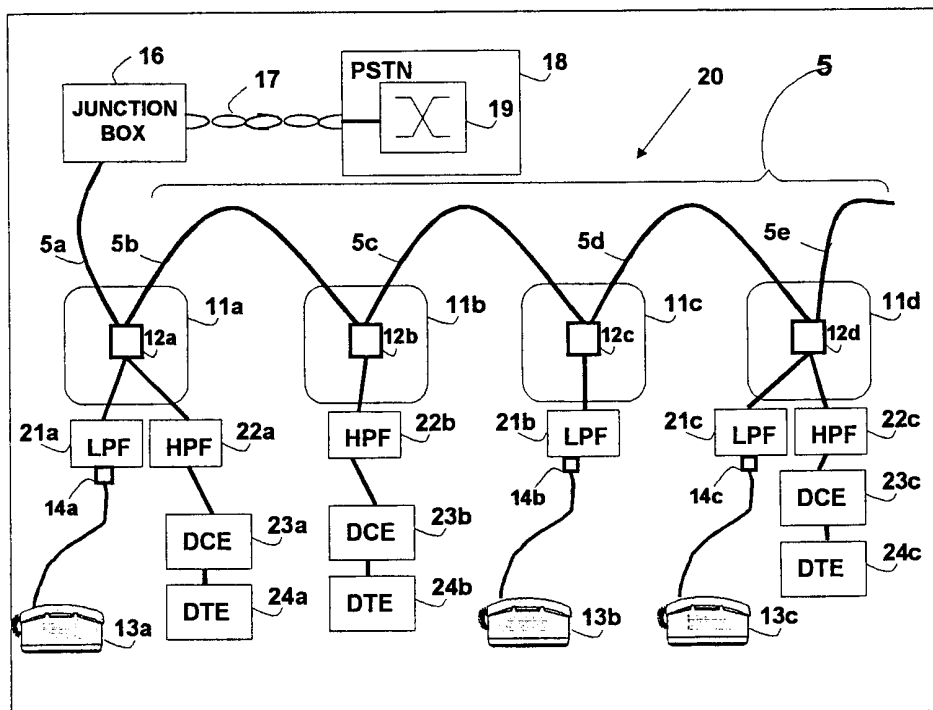

FIG. 2. (PRIOR ART)

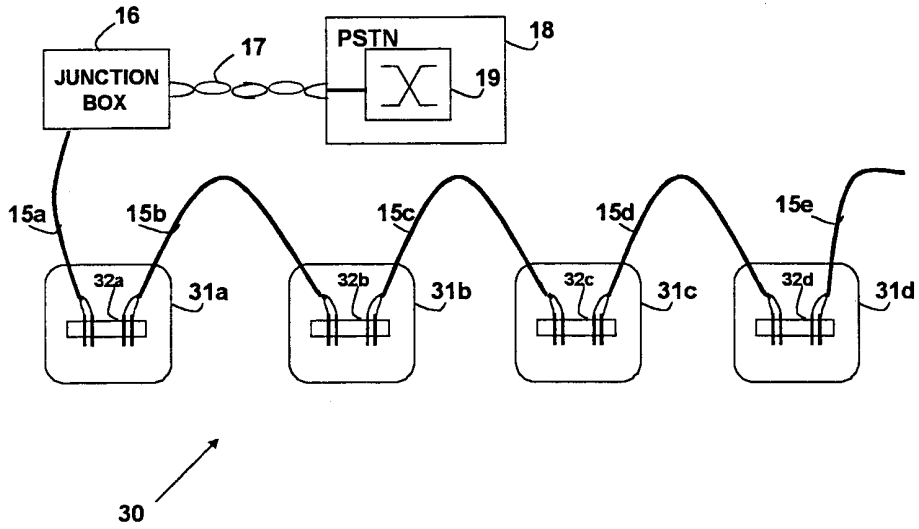

FIG. 3.

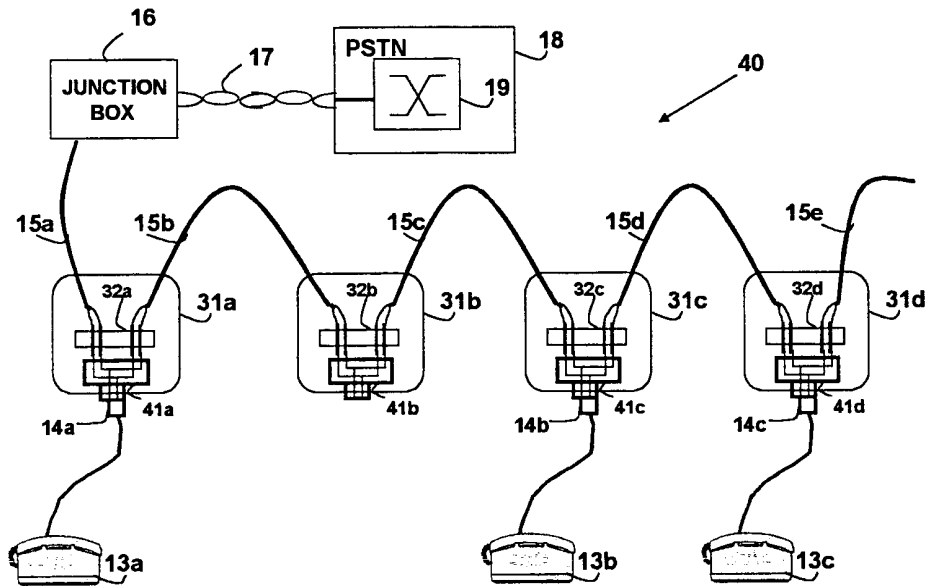

FIG. 4.

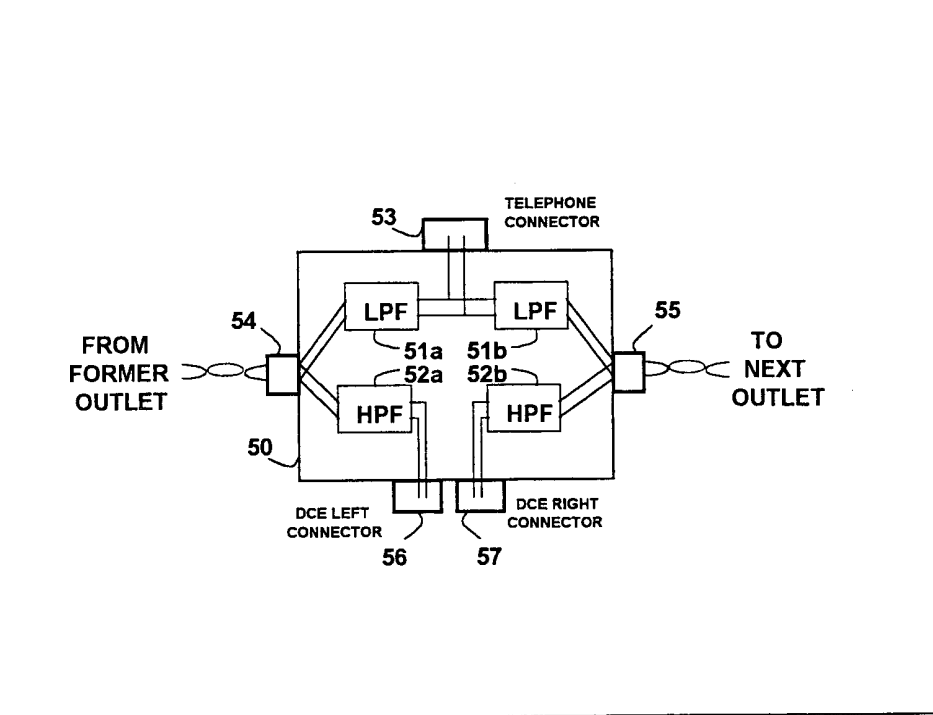

FIG. 5.

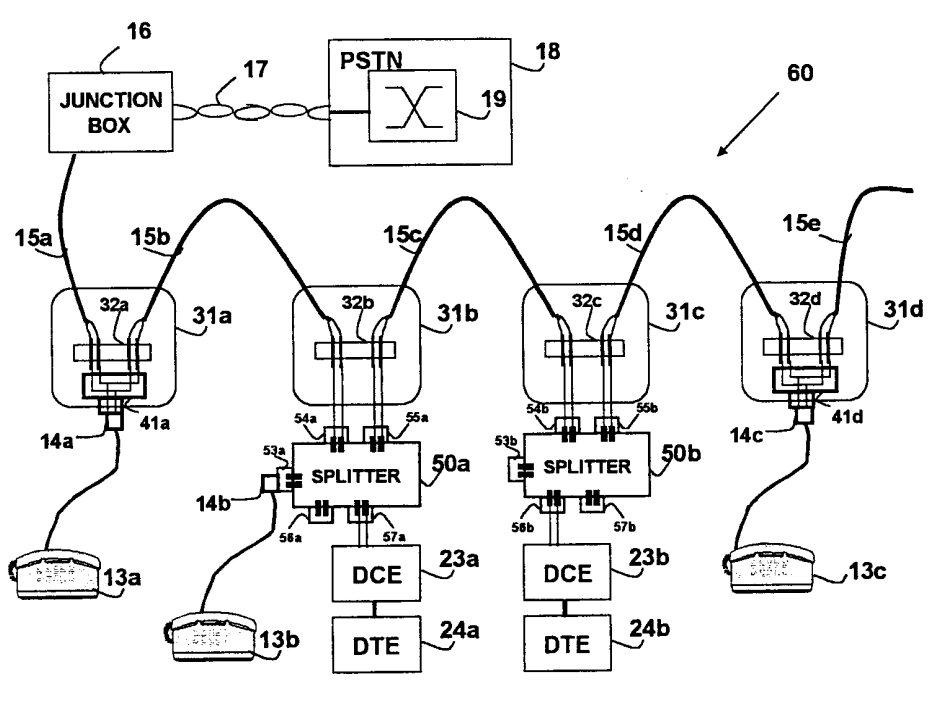

FIG. 6.

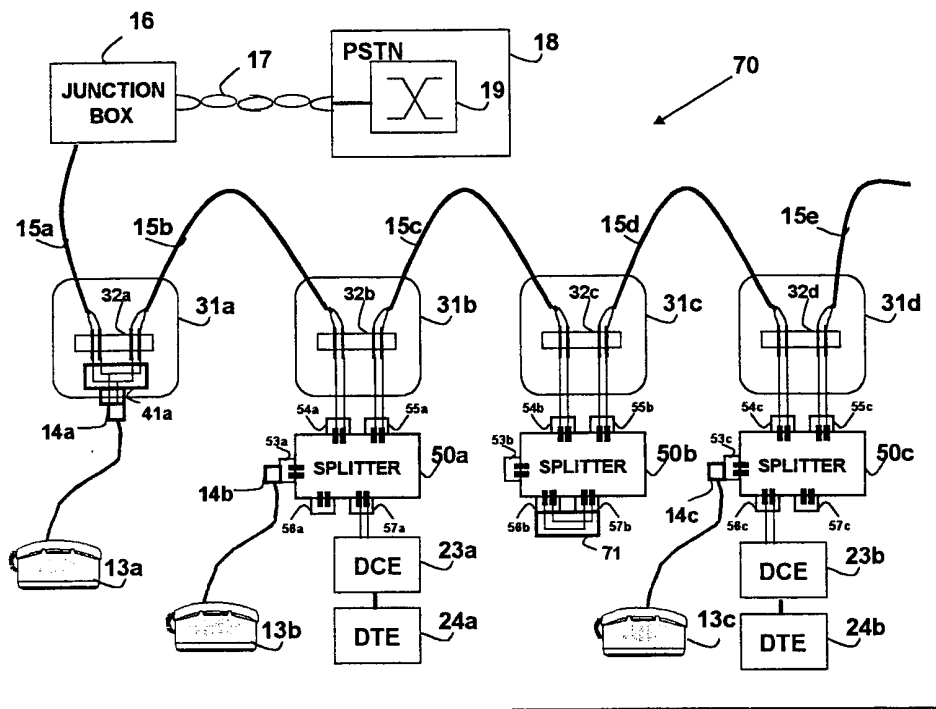

FIG. 7.

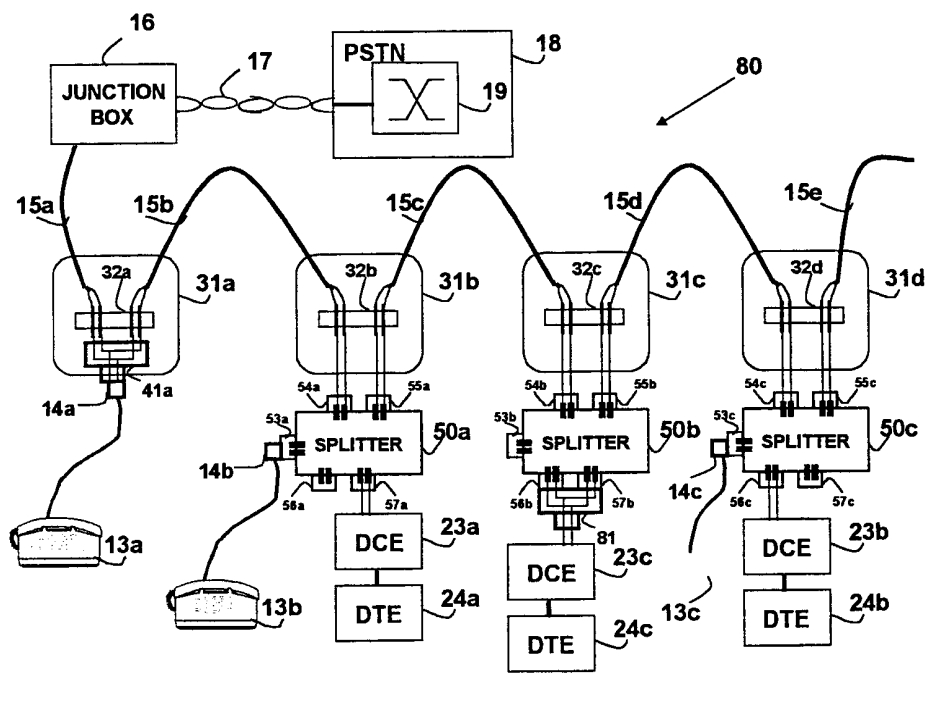

FIG. 8.

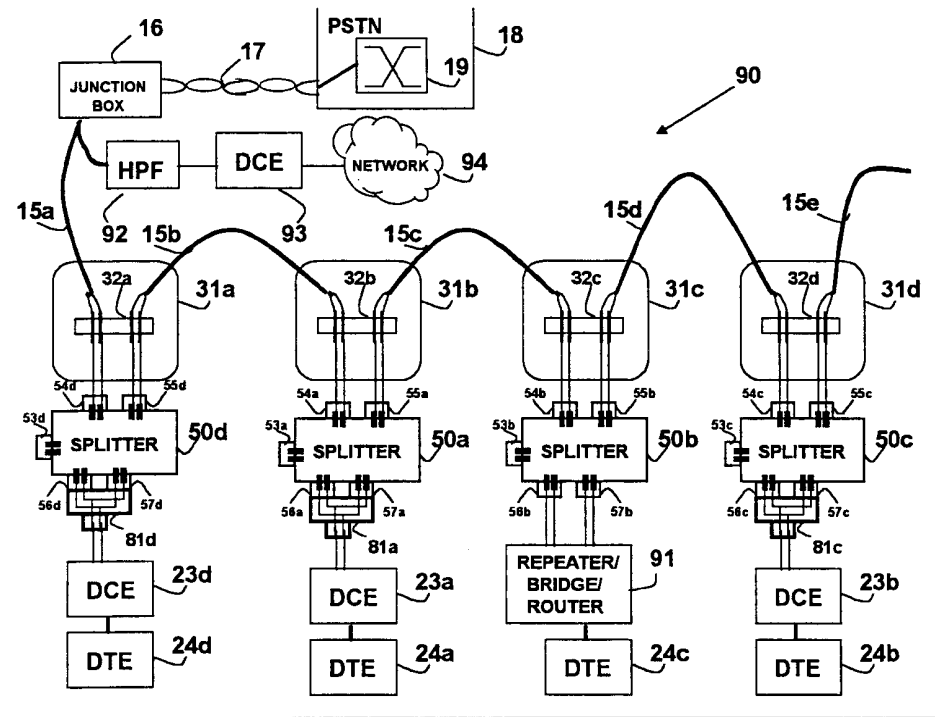

FIG. 9.

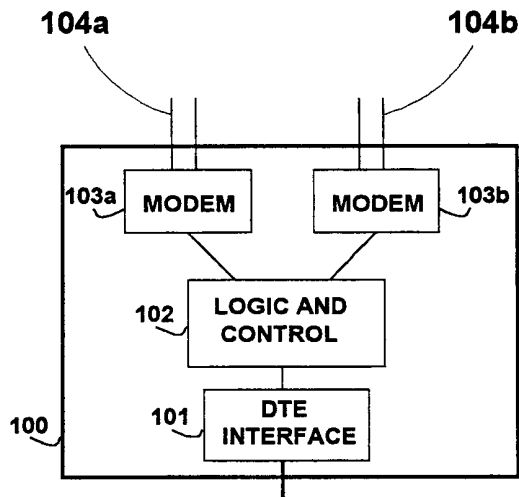

FIG. 10.

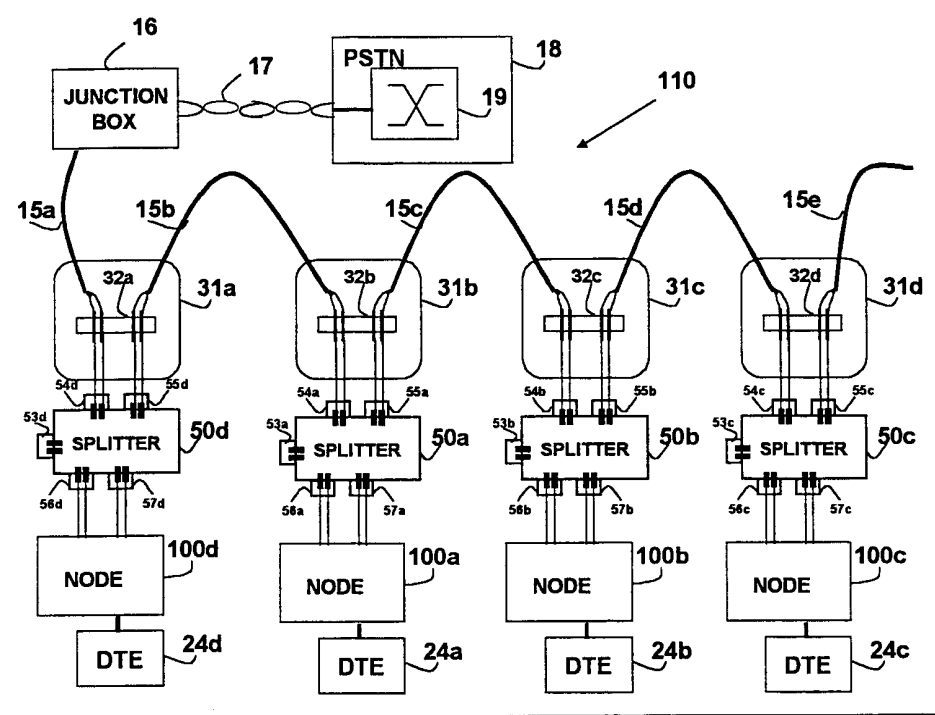

FIG. 11.

INTERNATIONAL SEARCH REPORT

International Application No
PCT/IL 00/00128

A. CLASSIFICATION OF SUBJECT MATTER
IPC 7 H04M11/06 H04L12/28

According to International Patent Classification (IPC) or to both national classification and IPC

B. FIELDS SEARCHED

Minimum documentation searched (classification system followed by classification symbols)
IPC 7 H04M H04L

Documentation searched other than minimum documentation to the extent that such documents are included in the fields searched

Electronic data base consulted during the international search (name of data base and, where practical, search terms used)

EPO-Internal, WPI Data, PAJ, INSPEC

C. DOCUMENTS CONSIDERED TO BE RELEVANT

Category °	Citation of document, with indication, where appropriate, of the relevant passages	Relevant to claim No.
A	WO 99 03255 A (ADVANCED MICRO DEVICES INC) 21 January 1999 (1999-01-21) page 12, line 8 - line 12 page 19, line 6 - line 22 ---	1-26
A	CHOW P S ET AL: "A MULTI-DDROP IN-HOUSE ADSL DISTRIBUTION NETWORK" INTERNATIONAL CONFERENCE ON COMMUNICATIONS (ICC), US, NEW YORK, IEEE, vol. -, 1 May 1994 (1994-05-01), pages 456-460, XP000438957 paragraph '0002! ---	1-26
A	WO 99 12330 A (TRAVERTINE SYSTEMS INC) 11 March 1999 (1999-03-11) page 3, line 23 -page 6, line 26 page 19, line 8 -page 22, line 17 -----	1-26

Further documents are listed in the continuation of box C. Patent family members are listed in annex.

° Special categories of cited documents :

<p>"A" document defining the general state of the art which is not considered to be of particular relevance</p> <p>"E" earlier document but published on or after the international filing date</p> <p>"L" document which may throw doubts on priority claim(s) or which is cited to establish the publication date of another citation or other special reason (as specified)</p> <p>"O" document referring to an oral disclosure, use, exhibition or other means</p> <p>"P" document published prior to the international filing date but later than the priority date claimed</p>	<p>"T" later document published after the international filing date or priority date and not in conflict with the application but cited to understand the principle or theory underlying the invention</p> <p>"X" document of particular relevance; the claimed invention cannot be considered novel or cannot be considered to involve an inventive step when the document is taken alone</p> <p>"Y" document of particular relevance; the claimed invention cannot be considered to involve an inventive step when the document is combined with one or more other such documents, such combination being obvious to a person skilled in the art.</p> <p>"&" document member of the same patent family</p>
--	--

Date of the actual completion of the international search 6 October 2000	Date of mailing of the international search report 13/10/2000
--	---

Name and mailing address of the ISA European Patent Office, P.B. 5818 Patentlaan 2 NL - 2280 HV Rijswijk Tel. (+31-70) 340-2040, Tx. 31 651 epo nl, Fax: (+31-70) 340-3016	Authorized officer Mikkelsen, C
--	---

INTERNATIONAL SEARCH REPORT

Information on patent family members

International Application No

PCT/IL 00/00128

Patent document cited in search report		Publication date		Patent family member(s)		Publication date
WO 9903255	A	21-01-1999	EP	0993734 A		19-04-2000
WO 9912330	A	11-03-1999	US	6069899 A		30-05-2000
			AU	8916798 A		22-03-1999