



- (51) International Patent Classification:
G02B 6/44 (2006.01)
- (21) International Application Number:
PCT/EP2013/052954
- (22) International Filing Date:
14 February 2013 (14.02.2013)
- (25) Filing Language: English
- (26) Publication Language: English
- (30) Priority Data:
61/600,895 20 February 2012 (20.02.2012) US
- (71) Applicant: TYCO ELECTRONICS RAYCHEM BVBA [BE/BE]; Diestsesteenweg 692, B-3010 Kessel-Lo (BE).
- (72) Inventors: GEENS, Johan; Walmersumstraat 32, B-3380 Bunsbeek (BE). VASTMANS, Kristof; Willebringestraat 14, B-3370 Boutersem (BE).
- (74) Agent: HEINZ-SCHAEFER, Marion; c/o Tyco Electronics UK Ltd, European Patent Department, Faraday Road, Dorcan, Swindon Wiltshire SN3 5HH (GB).
- (81) Designated States (unless otherwise indicated, for every kind of national protection available): AE, AG, AL, AM, AO, AT, AU, AZ, BA, BB, BG, BH, BN, BR, BW, BY, BZ, CA, CH, CL, CN, CO, CR, CU, CZ, DE, DK, DM,

DO, DZ, EC, EE, EG, ES, FI, GB, GD, GE, GH, GM, GT, HN, HR, HU, ID, IL, IN, IS, JP, KE, KG, KM, KN, KP, KR, KZ, LA, LC, LK, LR, LS, LT, LU, LY, MA, MD, ME, MG, MK, MN, MW, MX, MY, MZ, NA, NG, NI, NO, NZ, OM, PA, PE, PG, PH, PL, PT, QA, RO, RS, RU, RW, SC, SD, SE, SG, SK, SL, SM, ST, SV, SY, TH, TJ, TM, TN, TR, TT, TZ, UA, UG, US, UZ, VC, VN, ZA, ZM, ZW.

- (84) Designated States (unless otherwise indicated, for every kind of regional protection available): ARIPO (BW, GH, GM, KE, LR, LS, MW, MZ, NA, RW, SD, SL, SZ, TZ, UG, ZM, ZW), Eurasian (AM, AZ, BY, KG, KZ, RU, TJ, TM), European (AL, AT, BE, BG, CH, CY, CZ, DE, DK, EE, ES, FI, FR, GB, GR, HR, HU, IE, IS, IT, LT, LU, LV, MC, MK, MT, NL, NO, PL, PT, RO, RS, SE, SI, SK, SM, TR), OAPI (BF, BJ, CF, CG, CI, CM, GA, GN, GQ, GW, ML, MR, NE, SN, TD, TG).

Declarations under Rule 4.17:

- as to applicant's entitlement to apply for and be granted a patent (Rule 4.17(ii))
- of inventorship (Rule 4.17(iv))

Published:

- with international search report (Art. 21(3))

(54) Title: TELESCOPING CABLE MANAGEMENT DEVICES

FIG. 3

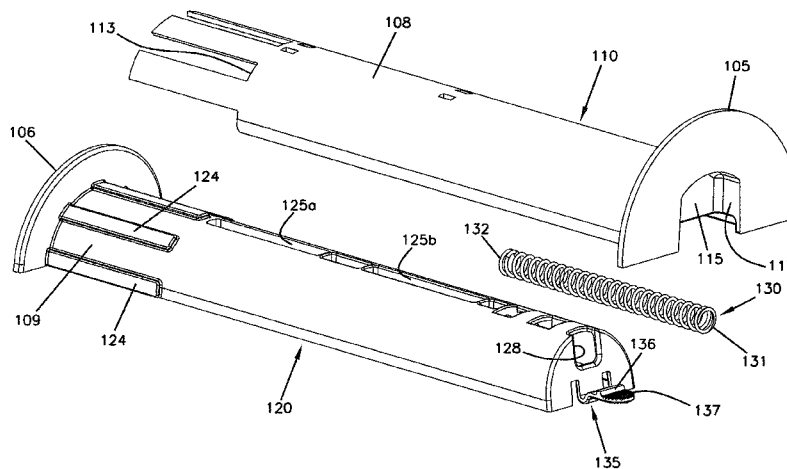

(57) Abstract: To manage slack storage, a first spool member (110) is extended relative to the second spool member (120); a fiber optic cable (150) is added to the first spool member (110) when in the extended position; and the first spool member (110) is pushed relative to the second spool member (120) to a retracted position. The first spool member (110) may be biased towards the extended position. The first spool member (110) may be releasably latched in the retracted position.

WO 2013/124204 A1

TELESCOPING CABLE MANAGEMENT DEVICES

Background

Cable management devices, such as cable spools, may be provided in cabinets, racks, or other structures for managing excess length (i.e., slack length) of fiber optic cables. For example, cable spools may extend from a surface in columns, rows, or other configurations. One or more fiber optic cables may be hung over or wrapped around a curved surface of one or more of these spools to take up the slack length of the fiber optic cable.

Summary

Aspects of the disclosure are directed to a telecommunications cable management device including a first spool member having a curved upper surface and a second spool member having a curved upper surface. The first spool member and the second spool member are telescopingly mounted to one another.

In certain implementations, the first spool member slides axially relative to the second spool member between retracted and extended positions. In certain implementations, the first spool member is biased towards the extended position. In certain implementations, the first spool member is releasably held in the retracted position. In certain implementations, the first and second spool members are shaped and configured so that the storage surface has a generally constant cross-dimension along a length of the storage surface regardless of whether the first spool member is retracted or extended.

Other aspects of the disclosure are directed to a method of using a telecommunications cable management device including providing a first spool member having a curved upper surface; and providing a second spool member having a curved upper surface. The first and second spool members are telescopingly mounted to one another. The method also includes extending the first spool member relative to the second spool member; adding a cable to the first spool member in the extended position; and pushing the first spool member relative to the second spool member to a retracted position.

Drawings

FIG. 1 is a top front schematic view of an example cable management device including a first spool member mounted to a second spool member in a retracted position;

FIG. 2 is a top front schematic view of the example cable management device of FIG. 1 with the first spool member in an extended position;

FIG. 3 is a top front schematic view of the example cable management device of FIG. 1 with the components exploded outward;

FIG. 4 is a top plan view of the first spool member of the cable management device of FIG. 1;

FIG. 5 is a bottom rear perspective view of the first spool member of FIG. 4;

FIG. 6 is a top plan view of the second spool member of the cable management
5 device of FIG. 1;

FIG. 7 is a top perspective view of the second spool member of FIG. 6;

FIG. 8 is a bottom, side perspective view of the second spool member of FIG. 6 with
part of one side removed so that an interior of the second spool member is visible;

FIG. 9 is a side elevational view of the cable management device of FIG. 1;

FIG. 10 is a cross-section taken along the longitudinal axis of the cable management
10 device of FIG. 9; and

FIG. 11 illustrates part of a cable management system including multiple cable
management devices mounted to a panel.

Detailed Description

15 Reference will now be made in detail to the example aspects of the present disclosure that are illustrated in the accompanying drawings. Wherever possible, the same reference numbers will be used throughout the drawings to refer to the same or like structure.

This disclosure is directed to a telecommunications cable management device 100
20 that facilitates adding one or more fiber optic cables 150 or optical fibers to a densely packed fiber storage region (see FIG. 11). Referring to FIGS. 1-3, the cable management device 100 includes a storage surface 108 that extends between a first end 101 and a second end 102. A first flange 105 is positioned at the first end 101 of the cable management device 100 to facilitate maintaining the fiber optic cables 150 on the storage surface 108. A
25 second flange 106 may be positioned at the second end 102 of the device 100. The second flange 106 may define one or more fastening apertures 107 via which the device 100 may be secured to a surface as will be disclosed in more detail herein.

In the example shown, the management device 100 has a semi-circle shaped lateral cross-dimensional profile. In other implementations, however the lateral cross-dimensional
30 profile of the management device 100 may be circular, oblong, obround, kidney-shaped, etc. The cable management device 100 also has at least one cross-dimension. In the example shown, the semi-circular shaped management device 100 has a height H (FIG. 9) extending between a top 103 and a bottom 104 of the device 100 and a diameter extending laterally

across the device 100. In other implementations, the device 100 (e.g., a circular shaped device) may have a constant cross-dimension.

The telecommunications cable management device 100 includes a first spool member 110 and a second spool member 120 that are telescopingly mounted to one another. As the term is used herein, first and second objects are telescopingly mounted to each other if the first object slides axially relative to the second object between a first position, in which the first object at least partially overlaps the second object, and a second position, in which the first object overlaps less of the second object. In certain implementations, the first object overlaps a majority of a length of the second object in the first position and overlaps less than half the length of the second object in the second position. The term “telescopingly mounted” does not imply that one object fully surrounds the other.

In the example shown, the first spool member 110 seats on the second spool member 120. The first spool member 110 is configured to slide axially relative to the second spool member 120 between a retracted position (FIG. 1) and an extended position (FIG. 2). When the first spool member 110 is in the retracted position, the storage surface has a first length L1 (FIG. 1). When the first spool member 110 moves to the extended position, the storage surface 108 of the device 100 expands to a second length L2 that includes an extension surface 109 (see FIG. 2).

In accordance with some aspects of the disclosure, the first spool member 110 may be biased towards the extended position. For example, a spring 130 may be disposed between the first and second spool members 110, 120 (see FIG. 3). For example, the spring 130 may have a first end 131 that abuts part of the first spool member 110 and a second end 132 that abuts parts of the second spool member 120. In the example shown, the spring 130 includes a coil spring. In other implementations, however, other types of springs may be utilized.

In accordance with some aspects of the disclosure, the first spool member 110 may be releasably held in the retracted position (see FIG. 1) as will be disclosed in more detail herein. For example, in certain implementations, the first spool member 110 may be latched to the second spool member 120 against the bias of the spring 130. In other implementations, the first spool member 110 may be releasably held in both the retracted position and the extended position and freely moveable between the two.

In accordance with some aspects of the disclosure, the first and second spool members 110, 120 are configured so that a cross-dimension of the storage surface 108 is generally constant along the length L1, L2 of the storage surface 108, even when the first

spool member 110 is in the extended position. For example, at least a portion of the second spool member 120 may be shaped and configured to have a cross-dimension CD2 that is the same as a cross-dimension CD1 of the first spool member 110.

FIGS. 4 and 5 illustrate one example implementation of a first spool member 110.

5 The first spool member 110 includes an elongated body extending between a first end 111 and a second end 112. The elongated body of the first spool member 110 defines a curved exterior surface. In some implementations, the first spool member 110 has a half-ring shaped lateral cross-sectional profile. In other implementations, the first spool member 110 has a circular lateral cross-sectional profile. In still other implementations, the first spool
10 member 110 has an oblong, obround or otherwise curved cross-sectional profile.

The first flange 105 is disposed at the first end 111 of the first spool member 110. One or more elongated slots 113 are defined at the second end 112 of the first spool member 110. The slots 113 are open-ended and extend inwardly from the second end 112. In some implementations, the slots 113 extend along less than half of a length of the first spool
15 member 110. In certain implementations, the slots 113 extend along less than a third of the length of the first spool member 110. The elongated slots 113 are circumferentially spaced around the curved surface of the first spool member 110. In certain implementations, the slots 113 have a generally rectangular profile. In other implementations, however, the slots 113 may be tapered or contoured. In certain implementations, partial slots 113a or notches
20 are cut into the sides of the elongated body (see FIG. 5).

Guide fingers 114 extend downwardly from an interior surface of the elongated body of the first spool member 110. In certain implementations, the guide fingers 114 define shoulders, hooks, or other lateral protrusions at the distal ends of the guide fingers 114. In some implementations, sets of two or more guide fingers 114 extend downwardly together.
25 In the example shown, each set includes two guide fingers 114 having protrusions extending in opposite directions. In other implementations, the sets may include additional guide fingers 114. In the example shown, a first set of guide fingers 114a is axially spaced from a second set of guide fingers 114b. In other implementations, the first spool member 110 includes a greater or lesser number of sets.

30 A stop flange 115 is disposed towards the first end 111 of the first spool 110. A first spring peg 116 extends inwardly from the stop flange 115. In some implementations, the stop flange 115 is disposed flush with the first end 111 of the first spool 110. In other implementations, the stop flange 115 is offset inwardly from the first end 111 to define a front recess 117. In the example shown, the stop flange 115 is inwardly offset from the

radially extending surface of the first flange 105. In the example shown, the stop flange 115 has a semi-circular shape.

FIGS. 6-8 illustrate one example implementation of a second spool member 120. The second spool member 120 includes an elongated body extending between a first end 121 and a second end 122. The elongated body of the second spool member 133 defines a curved exterior surface. In some implementations, the second spool member 120 has a half-ring shaped lateral cross-sectional profile. In other implementations, the second spool member 120 has a circular lateral cross-sectional profile. In still other implementations, the second spool member 120 has an oblong, obround or otherwise curved cross-sectional profile.

The second flange 106 is disposed at the second end 122 of the second spool member 120. In certain implementations, an alignment key 123 extends outwardly from the second flange 106. In the example shown, the alignment key 123 is generally cylindrical. In other implementations, however, the alignment key 123 may have any desired shape.

One or more raised ribs 124 are defined at the second end 122 of the second spool member 120. The ribs 124 extend from an inner surface of the second flange 106 towards the first end 121 of the second spool member 120. In some implementations, the ribs 124 extend along less than half of a length of the second spool member 120. In certain implementations, the ribs 124 extend along less than a third of the length of the second spool member 120. The elongated ribs 124 are circumferentially spaced around the curved surface of the second spool member 120. In certain implementations, the ribs 124 have a generally rectangular cross-sectional profile. In other implementations, however, the ribs 124 may be tapered along their height and/or length.

One or more elongated openings 125 are defined in the curved upper surface of the second spool member 120. In the example shown, first and second elongated openings 125 are defined in the curved upper surface in axial alignment. In other implementations, the second spool member 120 may include a greater or lesser number of openings 125. In the example shown, a first opening 125a is axially spaced from a second opening 125b by an intermediate opening. In other implementations, a solid surface may extend between the openings 125.

The first and second spool members 110, 120 are configured to fit together. In the example shown, the first spool member 110 is configured to seat on the second spool member 120 so that the first flange 105 is disposed opposite the second flange 106 (see FIG. 9). The ribs 124 of the second spool member 120 are sized and shaped to fit within the slots

113 of the first spool member 110. For example, the ribs 124 may be sized and shaped to slide axially within the slots 113. The guide fingers 114 of the first spool member 110 are sized and shaped to extend into the elongated openings 125 of the second spool member 120. The guide fingers 114 are configured to slide within the elongated openings 125 as the
5 first spool member 110 is moved between the retracted and extended positions.

The second spool member 120 also includes a spring base 126 from which a second spring peg 127 extends towards the first end 121 of the second spool member 120. The spring base 126 is recessed axially inward from the first end 121. The first end of the second spring member 120 also defines an opening 128 that generally aligns with the second
10 spring peg 127. In certain implementations, a support member 129 is disposed between the second spring peg 127 and the opening 128. In the example shown, the support member 129 includes a generally U-shaped flange that defines a tunnel or passage therethrough.

The spring 130 (FIG. 3) mounts between the first and second spool members 110, 120. For example, the first end 131 of the spring 130 may be mounted over the first spring
15 peg 116 and the second end 132 of the spring 130 may be mounted over the second spring peg 127. The body of the spring 130 extends through the opening 128 and the support member 129. The spring 130 biases the first spool member 110 away from the second end 122 of the second spool member 120 so that the slots 113 pull away from the ribs 124 and the guide fingers 114 move within the elongated openings 125 towards the first end 121 of
20 the second spool member 120.

In some implementations, the first and second spool members 110, 120 are configured to releasably secure together in one or more positions. For example, the first spool member 110 may be releasably latched to the second spool member 120 against the bias of the spring 130. As shown in FIGS. 6-8, a flexible tab 135 extends forwardly of the
25 first end 121 of the second spool 120. In some implementations, the flexible tab 135 includes a contoured section (e.g., a C-shaped section, a J-shaped section, an S-shaped section, etc.) forming a spring. A latching member 136 is disposed on the flexible tab 135 so that the latching member 136 may be moved relative to the second spool member 120. A grip surface 137 extends outwardly from the contoured section of the flexible tab 135.

30 As shown in FIG. 10, the flexible tab 135 extends forwardly past the stop flange 115 of the first spool member 110 when the first spool member 110 is seated on the second spool member 120. In some implementations, the flexible tab 135 extends into the front recess 117 of the first spool member 110. In certain implementations, the flexible tab 135 does not extend past the first end 111 of the first spool member 110 (see FIGS. 1 and 10). The

flexible tab 135 extends sufficiently forward so that the latch member 136 is disposed at an opposite side of the stop flange 115 from the spring 130. The latch member 136 abuts the forward side of the stop flange 115 to inhibit movement of the first spool member 110 to the extended position.

5 To extend the first spool member 110, a user depresses the grip surface 137, thereby depressing the latch member 136. When the latch member 136 clears the stop flange 115, the first spool member 110 is free to move under the bias of the spring 130. In some implementations, when the spool member 110 is in the extended position, the guide fingers 114 of the first spool member 110 abut forward ends of the elongated openings 125.

10 Accordingly, the guide fingers 114 inhibit continued movement of the first spool member 110 off the second spool member 120.

As shown in FIGS. 9 and 10, the ribs 124 of the second spool member 120 are sufficiently raised off the curved upper surface of the second spool member 120 to be generally flush with the curved upper surface of the first spool member 110. Accordingly, a

15 cross-dimension taken of the ribbed portion of the storage surface 108 of the cable management device 100 is about the same as a cross-dimension taken through the rest of the storage surface 108 of the cable management device 100. In certain implementations, the ribs 124 of the second spool member 120 are still partially disposed within the slots 113 of the first spool member (see FIG. 2) when the first spool member 110 is extended.

20 Accordingly, the storage surface 108 may be extended (i.e., the length may be increased) without reducing the dimensions of the lateral cross-sectional profile of any location along the storage surface 108. The ribs 124 maintain the same bend radius of the fiber or cable 150 as the management device 100 moves between retracted and extended positions.

25 Accordingly, the first spool member 110 does not crush or otherwise apply force to the fibers or cables 150 when the first spool member 110 is moved from the extended position back to the retracted position.

FIG. 11 illustrates a cable management system in which multiple cable management devices 100 are mounted to a panel 140 or other structure. The panel 140 has a mounting surface 141. The cable management devices 100 are mounted to the panel so that the second

30 flanges 106 are disposed against the mounting surface of the panel 140. In some implementations, the panel 140 defines alignment openings through which the alignment key 123 of the second spool member 120 may extend. One or more fasteners may be inserted through fastening apertures 107 defined in the second flange 106 and fastening apertures defined in the panel 140.

As shown in FIGS. 9 and 11, the second flange 106 of certain types of cable management devices 100 extends non-parallel to the first flange 105. In certain implementations, the first flange 105 extends generally perpendicular to the longitudinal axis of the cable management device 100. The second flange 106 extends at an angle ϕ from a perpendicular plane to the longitudinal axis. In some implementations, the angle ϕ ranges from about 5 degrees to about 20 degrees. In certain implementations, the angle ϕ ranges from about 10 degrees to about 15 degrees. In one example implementation, the angle ϕ is about 10 degrees.

In the example shown, the second flange 106 extends towards the first end 101 of the cable management device 100. Accordingly, the cable management device 100 extends outwardly from the panel 140 at an upward angle when installed to a vertically extending panel 140 (see FIG. 11). This upward angling of the management device 100 facilitates retaining the optical fibers or cables 150 on the management device 100. For example, in some implementations, the upward angling results in a tendency of the fibers or cables 150 to fall/slide/migrate towards the mounting surface 141 of the panel 140.

As shown in FIG. 11, the cable management devices 100 define a storage region 145 between the mounting surface 141 of the panel 140 and the first ends 101 of the cable management devices 100. When the cable management devices 100 are densely installed on the panel 140 (e.g., when the management devices 100 are spaced close to each other), the first flanges 105 and/or the stored fibers or cables 150 may inhibit a user from extending hands or even fingers into the storage region 145. The grip surface 137 of the latching tab 135 is accessible within the recessed area 117 at the first end 101 of the management device 100.

Accordingly, moving one of the management devices 100 to an extended position (e.g., by depressing the latching tab 135) facilitates adding optical fibers or cables 150 to such a densely packed storage region 145 (see FIG. 11). The optical fiber or cables 150 may be added to the first end 101 of the management device 100 at a location outside the densely packed storage region 145 (see FIG. 11). The ribs 124 maintain any fibers or cables 150 already stored on the management device 100 at a position that allows the second end 112 of the first spool member 110 to slide beneath them when the management device 100 is pushed back to the retracted position.

In some implementations, moving one of the management devices 100 to an extended position also facilitates removing one or more optical fibers or cables 150 from a densely packed storage region 145. For example, extending the first spool member 110 may

move the first flange 105 sufficiently to provide a gap at the front of the storage region 145 into which a user may slide their hands or fingers.

The above specification, examples and data provide a complete description of the manufacture and use of the composition of the invention. Since many embodiments of the invention can be made without departing from the spirit and scope of the invention, the
5 invention resides in the claims hereinafter appended.

Parts List

	100	cable management device
	101	first end
5	102	second end
	103	top
	104	bottom
	105	first flange
	106	second flange
10	107	fastening aperture
	108	storage surface
	109	extension surface
	L1	first length
	L2	second length
15	H	height
	110	first spool member
	111	first end
	112	second end
	113	slots
20	114	guide fingers
	115	stop flange
	116	first spring peg
	117	front recess
	CD1	first cross-dimension
25	120	second spool member
	121	first end
	122	second end
	123	alignment key
	124	raised ribs
30	125	elongated opening(s)
	125a	first elongated opening
	125b	second elongated opening
	126	spring base
	127	second spring peg

	128	front opening
	129	support member
	CD2	second cross-dimension
	130	spring
5	131	first end
	132	second end
	135	flexible tab
	136	latching shoulder
	137	grip surface
10	140	panel
	141	mounting surface
	142	key openings
	145	storage region
	150	fiber optic cables

CLAIMS:

1. A telecommunications cable management device (100), comprising:
a first spool member (110) having a curved upper surface;
5 a second spool member (120) having a curved upper surface;
wherein the first spool member (110) and the second spool member (120) are
telescopingly mounted to one another.
2. The telecommunications cable management device (100) of claim 1, wherein the
10 first and second spool members (110, 120) are half spools.
3. The telecommunications cable management device (100) of any of claims 1 and 2,
wherein the first spool member (110) has first and second ends (111, 112), and the second
spool member (120) has first and second ends (121, 122); wherein the second end (112) of
15 the first spool member (110) receives the first end (121) of the second spool member (120),
wherein the second end (122) of the second spool member (120) is mountable to a panel,
and wherein the first end (111) of the first spool member (110) includes a flange (105).
4. The telecommunications cable management device (100) of any of claims 1-3,
20 wherein the first spool member (110) is configured to slide axially relative to the second
spool member (120) between a retracted position and an extended position.
5. The telecommunications cable management device (100) of any of claims 1-4,
wherein the first spool member (110) defines slots (113) at the second end (112) and the
25 second spool member (120) includes raised ribs (124) at the second end (122), the raised
ribs (124) being sized and shaped to fit within the slots (113) when the first spool member
(110) is in the retracted position.
6. The telecommunications cable management device (100) of claim 5, wherein the
30 raised ribs (124) are sufficiently long that the raised ribs (124) extend partially into the slots
(113) when the first spool member (110) is in the extended position.

7. The telecommunications cable management device (100) of any of claims 4-6, wherein the first spool member (110) is configured to releasably lock to the second spool member (120) in the retracted position.

5 8. The telecommunications cable management device (100) of claim 7, wherein the first spool member (110) is configured to releasably latch to the second spool member (120) in the retracted position.

9. The telecommunications cable management device (100) of any of claims 4-8,
10 wherein the first spool member (110) is biased towards the extended position.

10. The telecommunications cable management device (100) of claim 9, wherein the first spool member (110) includes a stop flange (115) and the second spool member (120) includes a flexible tab (135) that is configured to latch to the stop flange (115).

15

11. The telecommunications cable management device (100) of claim 10, wherein a spring (130) extends through the first end (121) of the second spool member (120) and abuts the stop flange (115) of the first spool member (110).

12. The telecommunications cable management device (100) of any of claims 4-11,
20 wherein the first spool member (110) includes at least one guide finger (114) that extends through an elongated opening (125) defined in the curved upper surface of the second spool member (120), wherein the at least one guide finger (114) is configured to slide within the elongated opening (125) as the first spool member (110) moves between the retracted and
25 extended positions.

13. The telecommunications cable management device (100) of claims 1-11, further comprising:

a panel (140); and

30 a plurality of the first and second spool members (110, 120) telescopingly mounted to each other in pairs, each first spool member (110) having first and second ends (111, 112), and each second spool member (120) having first and second ends (121, 122);

wherein the second end (122) of each second spool member (120) is mounted to the panel (140), wherein the second end (112) of each first spool member (110) receives the first

end (121) of the respective second spool member (120), and wherein the first end (111) of the first spool member (110) includes a flange (105).

14. A method of using a telecommunications cable management device (100),
5 comprising:
 providing a first spool member (110) having a curved upper surface;
 providing a second spool member (120) having a curved upper surface; wherein the first spool member (110) and the second spool member (120) are telescopingly mounted to one another;
10 extending the first spool member (110) relative to the second spool member (120);
 adding a cable (150) to the first spool member (110) in the extended position; and
 pushing the first spool member (110) relative to the second spool member (120) to a retracted position.
- 15 15. The method of claim 14, wherein extending the first spool member (110) relative to the second spool member (120) comprises pulling the first spool member (110) axially outwardly from the second spool member (120).
16. The method of claim 14, wherein extending the first spool member (110) relative to
20 the second spool member (120) comprises releasing a latching engagement between the first spool member (110) and the second spool member (120).
17. The method of claim 16, wherein the first spool member (110) is biased towards the extended position, and wherein releasing a latching engagement between the first spool
25 member (110) and the second spool member (120) comprises depressing a grip surface (137) of a flexible tab (135) to move a latching shoulder (136) out of engagement with a stop flange (115).
18. The method of any of claims 14-17, wherein providing the first spool member (110)
30 and providing the second spool member (120) comprises providing a first cable management device (100) including the first and second spool members (110, 120) on a panel (140) along with a plurality of additional cable management devices (100), each of the additional cable management devices (100) including a respective first spool member (110) and a respective second spool member (120).

19. The method of claim 18, wherein extending the first spool member (110) relative to the second spool member (120) comprises extending the first spool member (110) relative to the first spool members (110) of the additional cable management devices (100) so that a
5 first end (101) of the first cable management device (100) extends past respective first ends (101) of the additional cable management devices (100) when the additional cable management devices (100) are in retracted positions.

20. The method of any of claims 14-19, wherein fingers of a user adding the cable (150)
10 to the first spool member (110) do not enter a storage region (145) of the panel (140) defined by the first ends (101) of the cable management devices (100) in the retracted positions.

FIG. 1

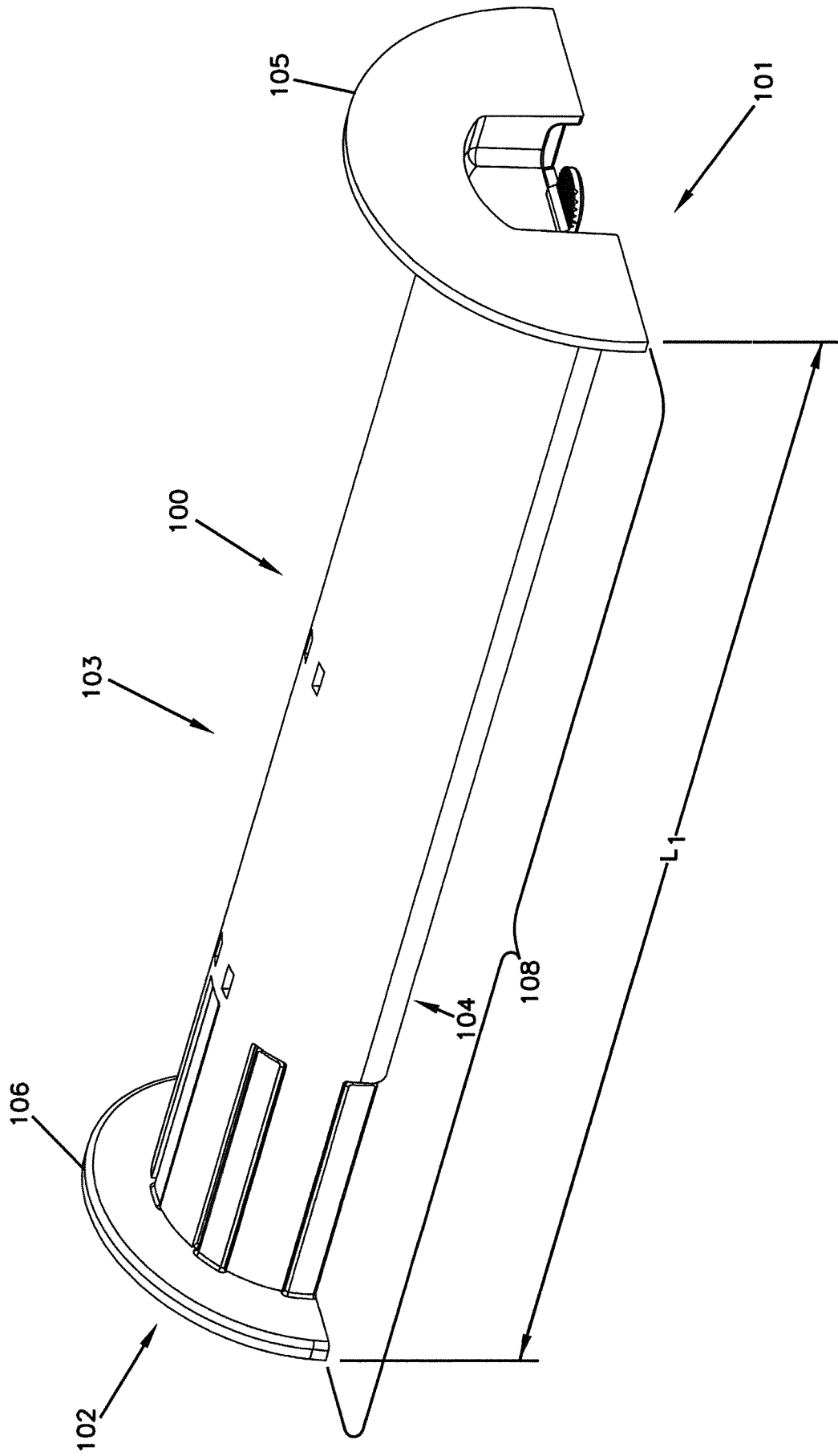

2/10

FIG. 2

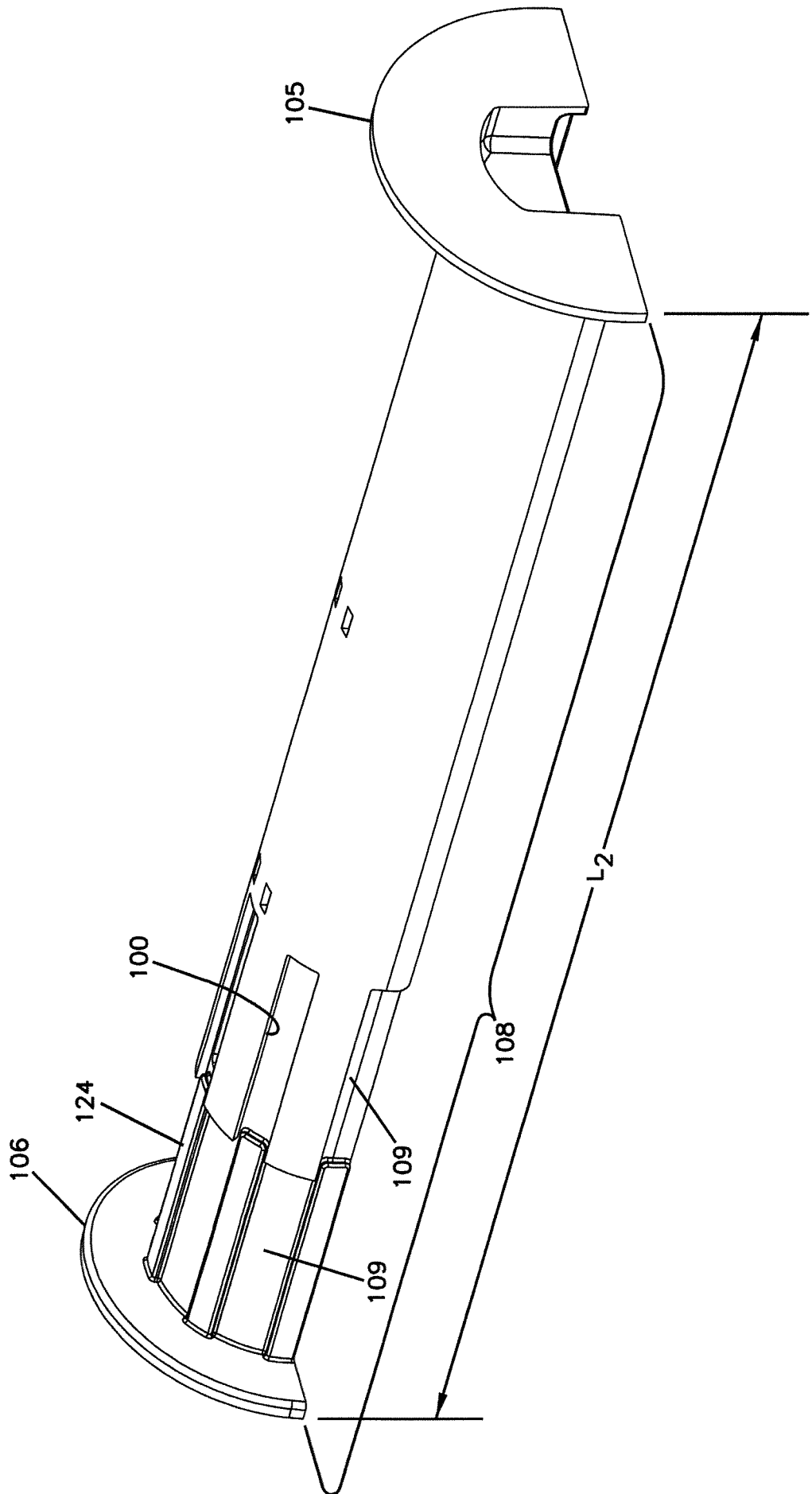
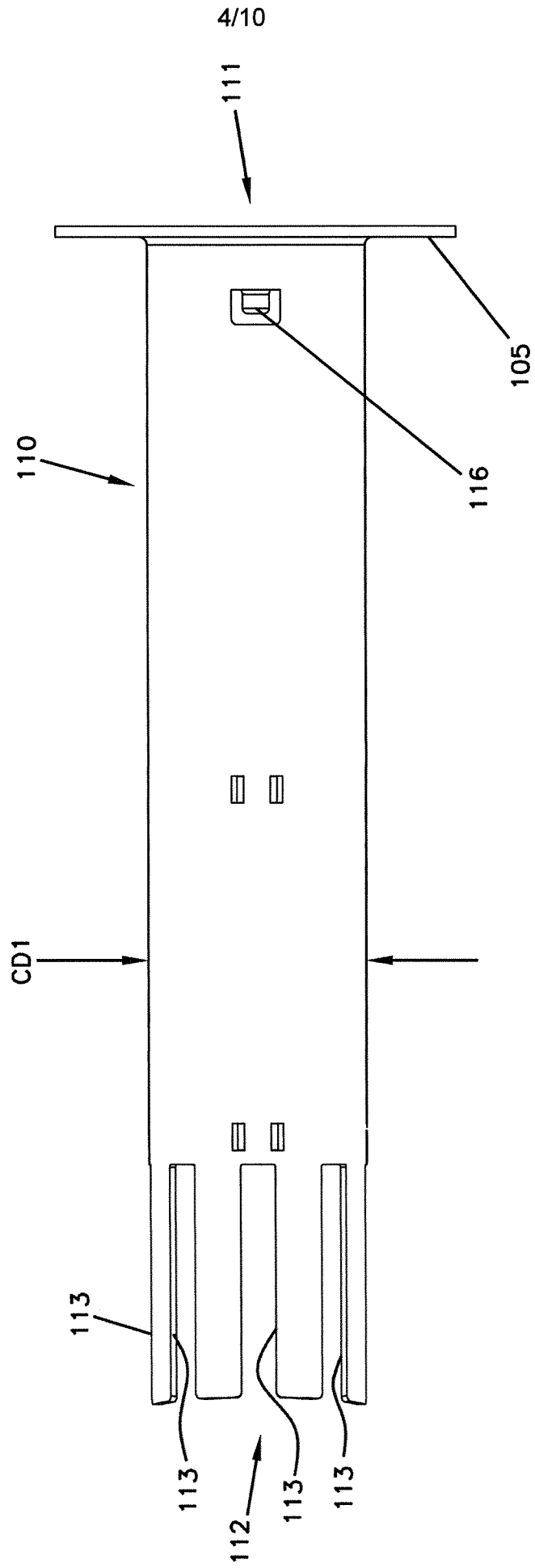

FIG. 4



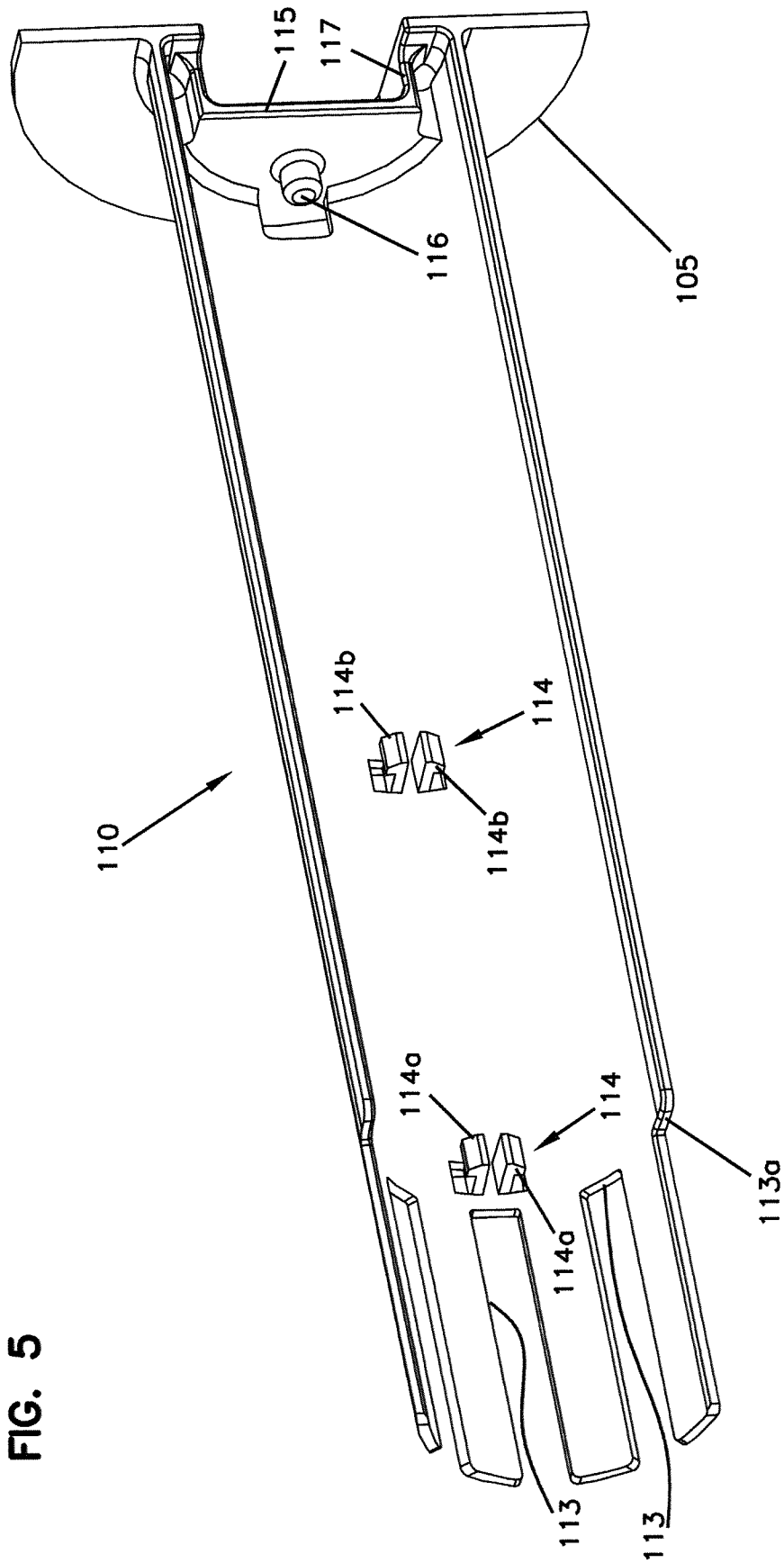
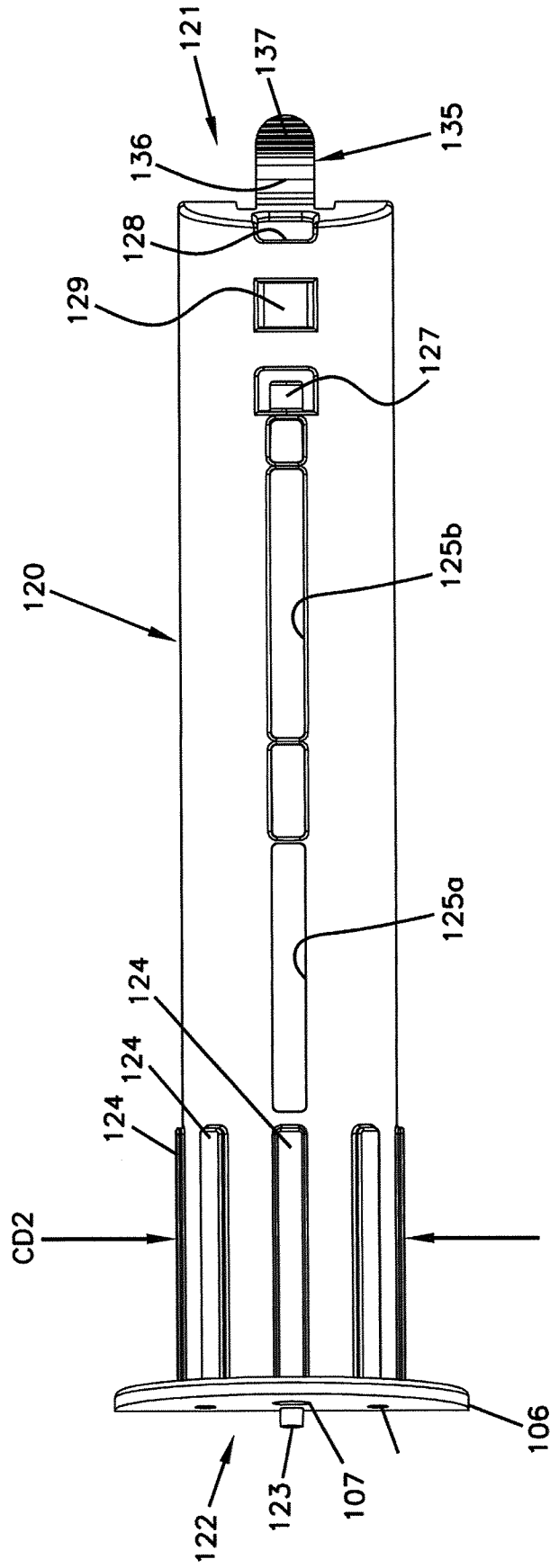

FIG. 5

FIG. 6



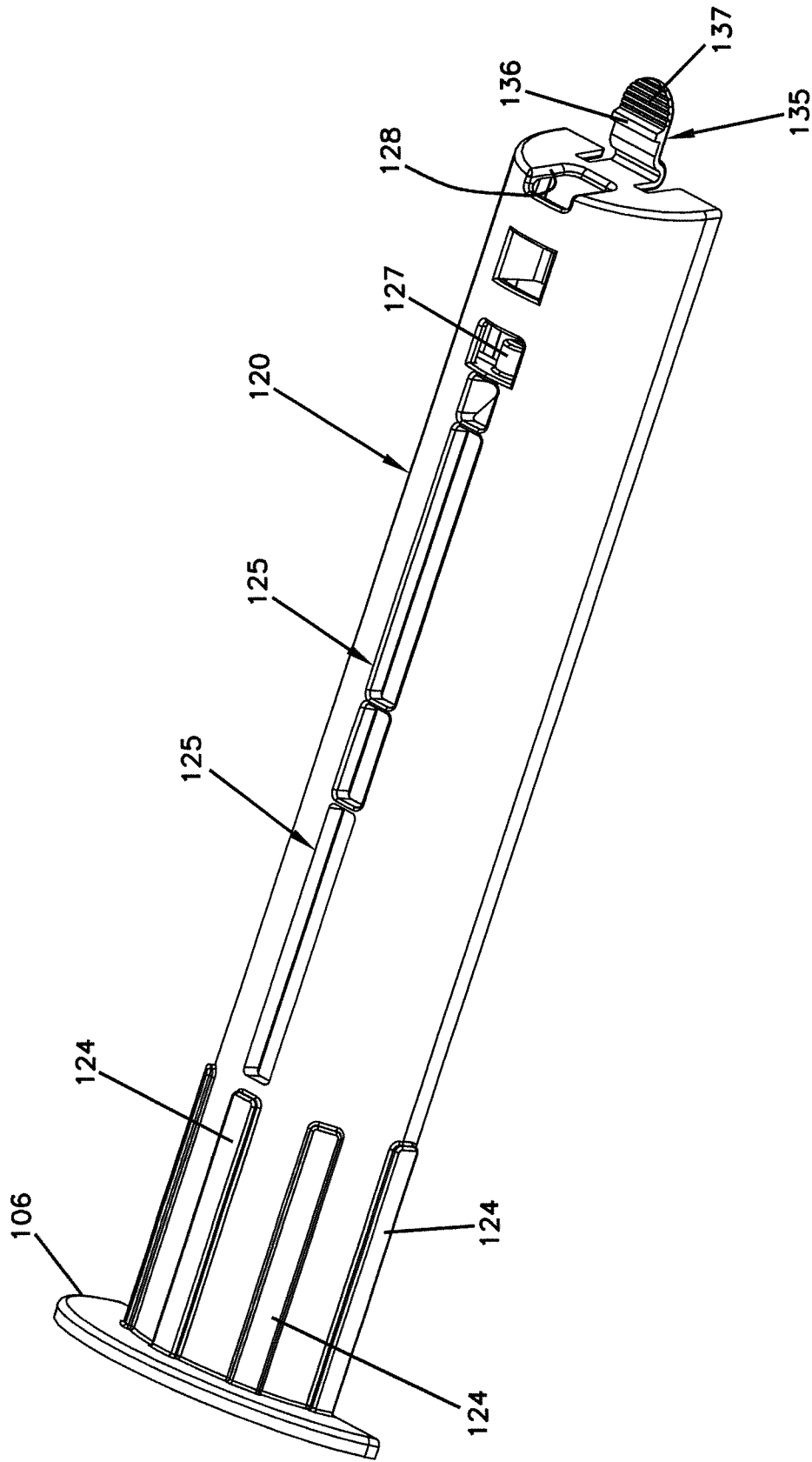
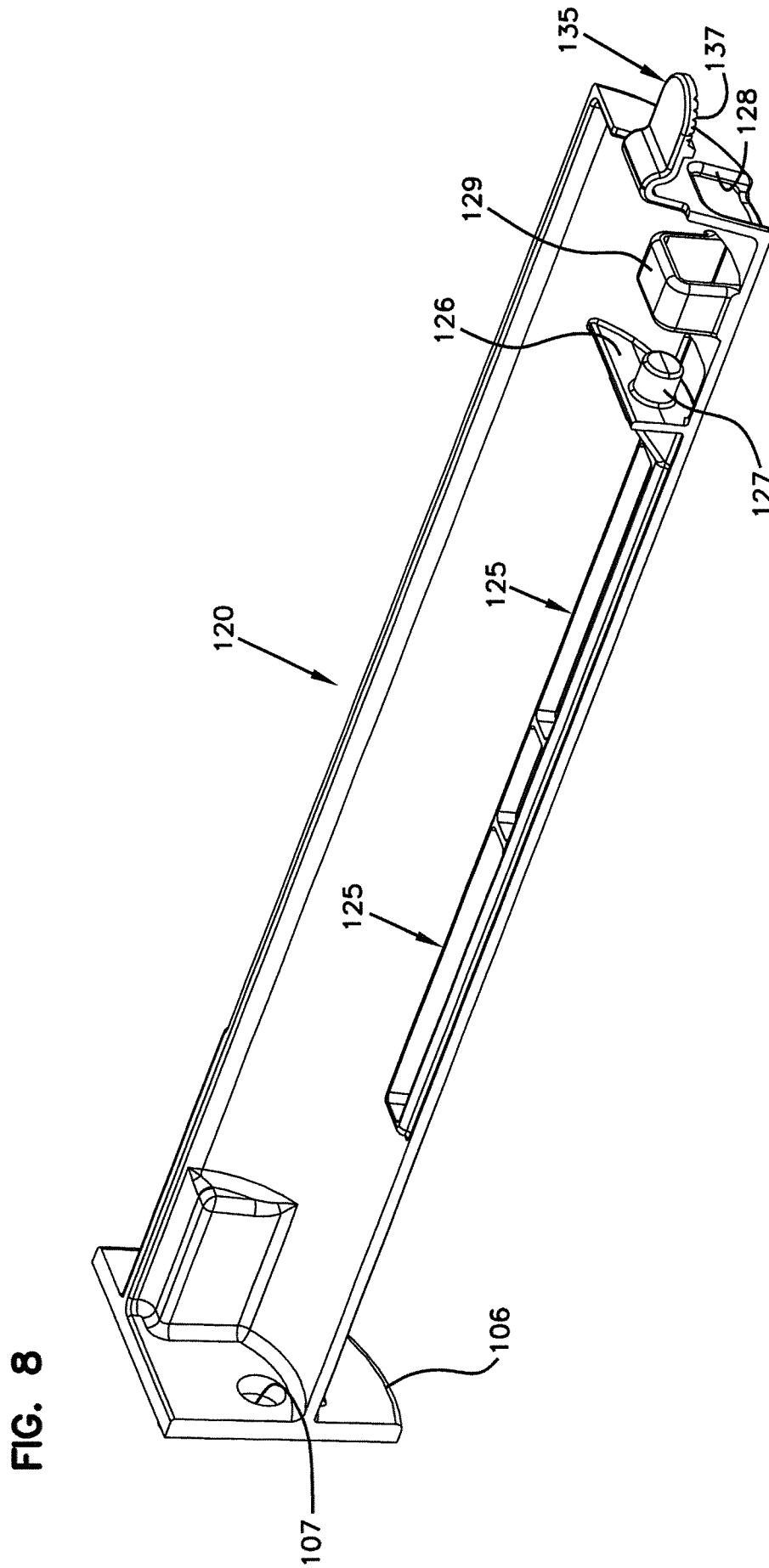
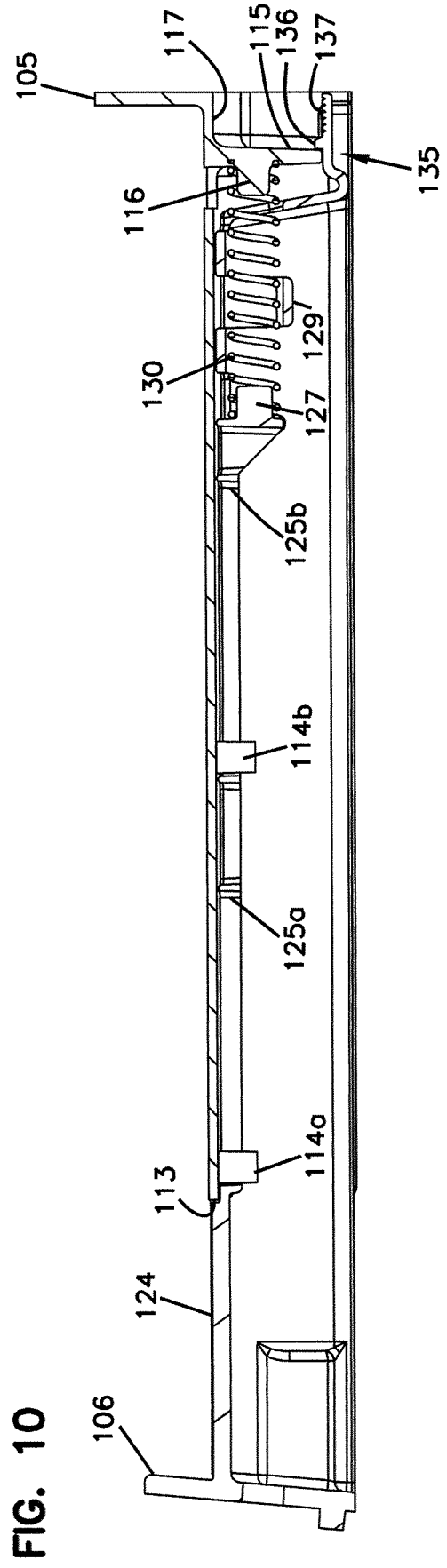
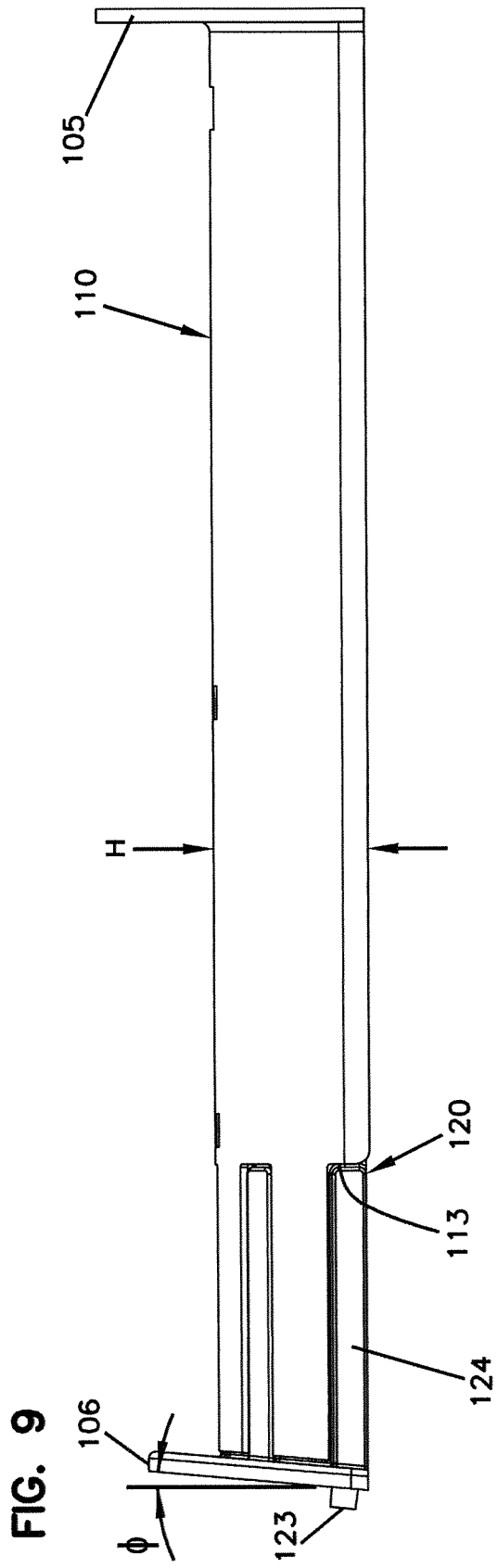

FIG. 7





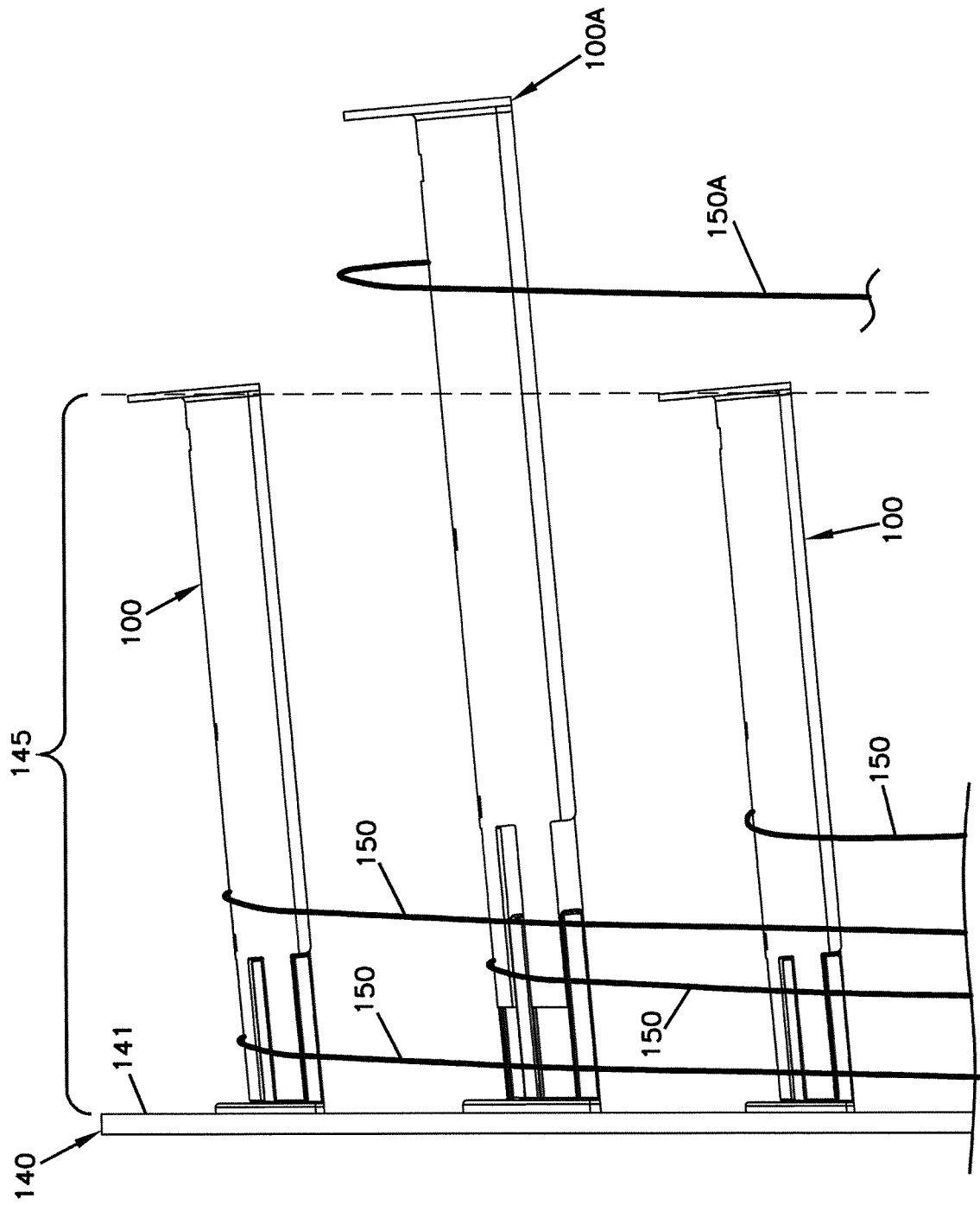

FIG. 11

INTERNATIONAL SEARCH REPORT

International application No
PCT/EP2013/052954

A. CLASSIFICATION OF SUBJECT MATTER
INV. G02B6/44
ADD.

According to International Patent Classification (IPC) or to both national classification and IPC

B. FIELDS SEARCHED
Minimum documentation searched (classification system followed by classification symbols)
G02B H02G

Documentation searched other than minimum documentation to the extent that such documents are included in the fields searched

Electronic data base consulted during the international search (name of data base and, where practicable, search terms used)
EPO-Internal

C. DOCUMENTS CONSIDERED TO BE RELEVANT		
Category*	Citation of document, with indication, where appropriate, of the relevant passages	Relevant to claim No.
X	GB 2 329 889 A (BICC PLC [GB] BICC PLC [GB]; BICC GEN UK CABLES LTD [GB]; PIRELLI CABL) 7 April 1999 (1999-04-07) page 6 figures 7,8 -----	1-20
X	GB 2 469 302 A (TOMLINSON ARTHUR LESLIE [GB]) 13 October 2010 (2010-10-13) abstract figure 6 -----	1-20
X	US 2009/294388 A1 (LEICHTER ERIC [US]) 3 December 2009 (2009-12-03) figure 3 abstract -----	1-20
	-/--	

Further documents are listed in the continuation of Box C.

See patent family annex.

* Special categories of cited documents :

- "A" document defining the general state of the art which is not considered to be of particular relevance
- "E" earlier application or patent but published on or after the international filing date
- "L" document which may throw doubts on priority claim(s) or which is cited to establish the publication date of another citation or other special reason (as specified)
- "O" document referring to an oral disclosure, use, exhibition or other means
- "P" document published prior to the international filing date but later than the priority date claimed

"T" later document published after the international filing date or priority date and not in conflict with the application but cited to understand the principle or theory underlying the invention

"X" document of particular relevance; the claimed invention cannot be considered novel or cannot be considered to involve an inventive step when the document is taken alone

"Y" document of particular relevance; the claimed invention cannot be considered to involve an inventive step when the document is combined with one or more other such documents, such combination being obvious to a person skilled in the art

"&" document member of the same patent family

Date of the actual completion of the international search 7 May 2013	Date of mailing of the international search report 15/05/2013
Name and mailing address of the ISA/ European Patent Office, P.B. 5818 Patentlaan 2 NL - 2280 HV Rijswijk Tel. (+31-70) 340-2040, Fax: (+31-70) 340-3016	Authorized officer Luck, Wulf

INTERNATIONAL SEARCH REPORT

International application No
PCT/EP2013/052954

C(Continuation). DOCUMENTS CONSIDERED TO BE RELEVANT		
Category*	Citation of document, with indication, where appropriate, of the relevant passages	Relevant to claim No.
X	GB 2 355 313 A (RAYCHEM SA NV [BE]; TYCO ELECTRONICS RAYCHEM NV [BE]) 18 April 2001 (2001-04-18) abstract	1-20
X	----- GB 2 356 062 A (RAYCHEM SA NV [BE]; TYCO ELECTRONICS RAYCHEM NV [BE]) 9 May 2001 (2001-05-09) abstract -----	1-20

INTERNATIONAL SEARCH REPORT

Information on patent family members

International application No

PCT/EP2013/052954

Patent document cited in search report	Publication date	Patent family member(s)	Publication date
GB 2329889	A	07-04-1999	ES 2157744 A1 16-08-2001 GB 2329889 A 07-04-1999
GB 2469302	A	13-10-2010	NONE
US 2009294388	A1	03-12-2009	NONE
GB 2355313	A	18-04-2001	NONE
GB 2356062	A	09-05-2001	NONE