

(19) AUSTRALIAN PATENT OFFICE

- (54) Title
In vivo detection of biomolecule concentrations using
fluorescent tags
- (51)⁶ International Patent Classification(s)
G01N 33/53 A61K 49/00
(2006.01) 20060101ALI20
A61K 49/00 060408BMEP
(2006.01) G01N 21/64
G01N 21/64 20060101ALI20
(2006.01) 060408BMEP
G01N 33/53 PCT/US01/4737
20060101AFI20 3
060101BHAU
- (21) Application No: 2002236590 (22) Application Date: 2001.11.07
- (87) WIPO No: W002/39112
- (30) Priority Data
- | | | |
|-------------|------------|--------------|
| (31) Number | (32) Date | (33) Country |
| 60/247,574 | 2000.11.09 | US |
- (43) Publication Date : 2002.05.21
(43) Publication Journal Date : 2002.07.25
- (71) Applicant(s)
Sicel Technologies, Inc.
- (72) Inventor(s)
Black, Robert D.
- (74) Agent/Attorney
Davies Collison Cave, Level 15 1 Nicholson Street, MELBOURNE,
VIC, 3000
- (56) Related Art
US 6070096 (HAYASHI KATSUMI) 30 May 2000
US 5833603 (KOVACS ET AL) 10 November 1998
US 6551838 B2 (SANTINI ET AL) 13 March 2003 (au equiv
AU2001252890 A 12 September 2001)

(12) INTERNATIONAL APPLICATION PUBLISHED UNDER THE PATENT COOPERATION TREATY (PCT)

(19) World Intellectual Property Organization
International Bureau



(43) International Publication Date
16 May 2002 (16.05.2002)

PCT

(10) International Publication Number
WO 02/039112 A3

- (51) International Patent Classification⁷: **A61B 5/00**
- (21) International Application Number: PCT/US01/47373
- (22) International Filing Date:
7 November 2001 (07.11.2001)
- (25) Filing Language: English
- (26) Publication Language: English
- (30) Priority Data:
60/247,574 9 November 2000 (09.11.2000) US
- (71) Applicant (for all designated States except US): **SICEL TECHNOLOGIES, INC.** [US/US]; 3800 Gateway Center Blvd., Suite 308, Morrisville, NC 27560 (US).
- (72) Inventor; and
- (75) Inventor/Applicant (for US only): **BLACK, Robert, D.** [US/US]; 203-8 Connor Drive, Chapel Hill, NC 27514 (US).
- (74) Agent: **CROUSE, Robert, N.**; Myers Bigel Sibley & Sajovec, P.O. Box 37428, Raleigh, NC 27627 (US).
- (81) Designated States (national): AE, AG, AL, AM, AT, AU, AZ, BA, BB, BG, BR, BY, BZ, CA, CH, CN, CO, CR, CU, CZ, DE, DK, DM, DZ, EC, EE, ES, FI, GB, GD, GE, GH, GM, HR, HU, ID, IL, IN, IS, JP, KE, KG, KP, KR, KZ, LC, LK, LR, LS, LT, LU, LV, MA, MD, MG, MK, MN, MW, MX, MZ, NO, NZ, OM, PH, PL, PT, RO, RU, SD, SE, SG, SI, SK, SL, TJ, TM, TR, TT, TZ, UA, UG, US, UZ, VN, YU, ZA, ZW.
- (84) Designated States (regional): ARIPO patent (GH, GM, KE, LS, MW, MZ, SD, SL, SZ, TZ, UG, ZW), Eurasian patent (AM, AZ, BY, KG, KZ, MD, RU, TJ, TM), European patent (AT, BE, CH, CY, DE, DK, ES, FI, FR, GB, GR, IE, IT, LU, MC, NL, PT, SE, TR), OAPI patent (BF, BJ, CF, CG, CI, CM, GA, GN, GQ, GW, ML, MR, NE, SN, TD, TG).
- Published:
with international search report
- (88) Date of publication of the international search report:
6 February 2003
- For two-letter codes and other abbreviations, refer to the "Guidance Notes on Codes and Abbreviations" appearing at the beginning of each regular issue of the PCT Gazette.

(54) Title: IN VIVO DETECTION OF BIOMOLECULE CONCENTRATIONS USING FLUORESCENT TAGS

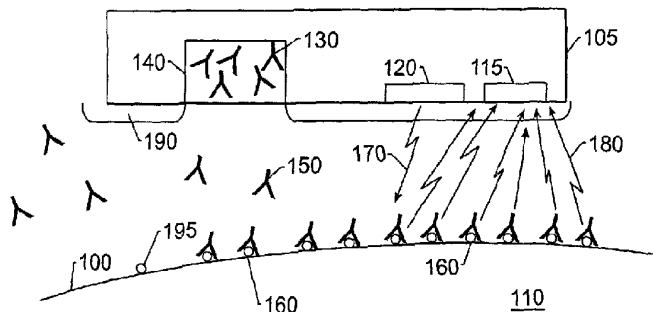

(57) Abstract: Methods are disclosed wherein labeled antibodies can be provided *in vivo* to tissue having antigens that specifically bind the labeled antibody. A first optical radiation is emitted into the tissue *in vivo* to excite the labeled antibody bound to the antigen *in vivo*. A second optical radiation that is emitted by the excited labeled antibody, in response to the excitation thereof, can be detected *in vivo*. Related telemetric circuits and compositions of matter are also disclosed.

WO 02/039112 A3

**METHODS, CIRCUITS AND COMPOSITIONS OF MATTER FOR IN VIVO
DETECTION OF BIOMOLECULE CONCENTRATIONS USING FLUORESCENT TAGS**

Claim for Priority and Cross-Reference to Related Applications

The present application claims priority to U.S. Provisional Application No. 60/247,574 filed November 9, 2000, entitled *Methods, Circuits, and Compositions of Matter for In Vivo Detection of Biomolecule Concentrations Using Fluorescent Tags*, the entire disclosure of which is hereby incorporated herein by reference.

Field of the Invention

5 The present invention relates to the field of sensors, and more particularly, to biomolecular sensors.

Background of the Invention

10 The *ex vivo* study of malignant cell populations has established some general principles by which clinical treatment protocols are developed. These principles have established differences between malignant and normal cell populations and have been employed in the treatment of malignant disease. There have been attempts to exploit these differences, both in pre-clinical and clinical studies, to obtain total tumor cell kills and improved cure rates.

15 One of the major obstacles in achieving this goal has been the difficulty in minimizing normal tissue toxicity while increasing tumor cell kill (therapeutic index). Thus, some treatment strategies employ an empirical approach in the treatment of malignant disease. In particular, the time of delivery and dose of cytotoxic agents can be guided more by the response and toxicity to normal tissue than by the effects on the malignant cell population.

20 Unfortunately, this approach may not provide accurate information on the changes during treatment of a malignant cell population. Making this information available may allow clinicians to exploit the differences between malignant and normal cells, and hence improve the treatment procedures.

25 There have been a number of attempts to study changes that occur within a cell population. However, these attempts have not shown the ability to monitor the changes on a real time basis. Indeed, these methods typically provide information at one point in time and most are designed to provide information on one particular function or parameter. In addition, most of the conventional methods can be expensive as well as time consuming.

This can be problematic for patients undergoing extended treatment periods typical of radiation and chemotherapy, especially when it is desirable to follow changes both during an active treatment and subsequent to the active treatment.

In addition, tumors may have periods in which they are more susceptible to treatment
5 by radiation or drug therapy. Providing a monitoring system which can continuously or semi-continuously monitor and potentially identify such a susceptible condition could provide increases in tumor destruction rates.

Numerous tumor specific antigens (TSA) have been identified and antibodies specific for a number of these TSA's are known. For example, it has been demonstrated that sigma-2
10 receptors found on the surface of cells of the 9L rat brain tumor cell line, the mouse mammary adenocarcinoma lines 66 (diploid) and 67 (aneuploid), and the MCF-7 human breast tumor cell line may be markers of tumor cell proliferation. See Mach RH et al., Sigma 2 receptors as potential biomarkers of proliferation in breast cancer. Cancer Res 1997 Jan
1;57(1):156-61; Al-Nabulsi I et al., Effect of ploidy, recruitment, environmental factors, and
15 tamoxifen treatment on the expression of sigma-2 receptors in proliferating and quiescent tumour cells. Br J Cancer 1999 Nov;81(6):925-33. Such markers may be amenable to detection by non-invasive imaging procedures. Accordingly, ligands that selectively bind sigma-2 receptors may be used to assess the proliferative status of tumors, although *in vivo* techniques utilizing such ligands have heretofore not been known. Although the field of
20 tumor-specific treatment is still relatively unsettled, various researchers have proposed several potentially important techniques useful in such treatment. For example, the *ex vivo* detection of biomolecules can be useful in predicting the timing for advantageous treatment of tumors. Many of these techniques use a "hybridization event" to alter the physical or chemical properties associated with the biomolecules. The biomolecules having the altered
25 property can be detected, for example, by optical or chemical means.

One known technique for the detection of biomolecules, called Enzyme-Linked Immunosorbent Assay (ELISA), involves the detection of binding between a biomolecule and an enzyme-labeled antibody specific for the biomolecule. Other methods of detecting biomolecules utilize immunofluorescence, involving the use of a fluorescently labeled
30 antibody to indicate the presence of the biomolecule. The *in vivo* use of these techniques may involve an invasive introduction of a sensor into the *in vivo* site to be analyzed. Moreover, these techniques may not be reliable if the surface where the sensor and the tissue interact is not clean. In particular, *in vivo* use can cause a sensor to become "bio-fouled" over time such that the operational properties of the sensor may change. In particular, proteins may

Attorney Docket No.: 9099-4

begin to develop on the sensor within minutes of insertion of the sensor into the tissue, which may cause the sensor to operate improperly. In view of the foregoing, there remains a need for circuits, compositions of matter, and methods which can be used to, *inter alia*, detect biomolecular concentrations *in vivo*.

5 U.S. Patent No. 5,833,603 to Kovacs et al. relates to a biosensing transponder for implantation in an organism including a human which includes a biosensor for sensing one or more physical properties related to the organism after the device has been implanted. U.S. Patent No. 5,939,4532 to Heller et al. relates to PEG-POE, PEG-POE-PEG, and POE-PEG-POE block copolymers have both hydrophilic and
10 hydrophobic blocks.

Summary of the Invention

Methods according to embodiments of the present invention can include providing labeled antibodies *in vivo* to tissue having antigens that specifically bind the
15 labeled antibody. A first optical radiation is emitted into the tissue *in vivo* to provide excite the labeled antibody bound to the antigen *in vivo*. A second optical radiation that is emitted by the excited labeled antibody in response to the excitation thereof can be detected *in vivo*. In some embodiments, the labeled antibodies are fluorescently labeled antibodies.

20 In other embodiments, the step of providing can include releasing the labeled antibodies *in vivo* from a matrix material over time. In other embodiments, the step of providing can include releasing the labeled antibodies *in vivo* from a matrix material responsive to a control circuit located *in vivo*.

25 In some embodiments, the step of exciting can include emitting the first optical radiation through a bio-fouling tissue. In other embodiments, the step of detecting can include detecting the second optical radiation through a bio-fouling tissue.

Accordingly, labeled antibodies can bind antigens associated with tumor cells. A radiation source can be used to excite the labeled antibodies bound to the antigens.
30 The labeled antibodies emit a second optical radiation in response to the excitation. A sensor can be used to detect a level of the optical radiation emitted by the labeled antibodies. The level of the second optical radiation can be used to determine the concentration of antigens present. The growth or proliferation of the tumor cells

2002236590 03 May 2006

- 3/1 -

may be approximated from the concentration of antigen. Embodiments of the invention advantageously integrate the ability to probe fluorescently tagged entities with an implantable sensor platform, thus allowing accurate, real time determinations of antigen concentration *in vivo*.

5

Brief Description of the Drawings

FIG. 1 is a schematic illustration of embodiments according to the present invention.

10 **FIG. 2** is a schematic illustration of embodiments according to the present invention.

FIG. 3 is a schematic illustration of matrix compositions of matter according to the present invention.

FIG. 4 is a schematic illustration of matrix compositions of matter according to the present invention.

FIG. 5 is a circuit diagram that illustrates embodiments according to the present invention.

5

Description of Embodiments of the Invention

The present invention now will be described more fully hereinafter with reference to the accompanying drawings, in which preferred embodiments of the invention are shown. This invention may, however, be embodied in many different forms and should not be
10 construed as limited to the embodiments set forth herein; rather, these embodiments are provided so that this disclosure will be thorough and complete, and will fully convey the scope of the invention to those skilled in the art. Like numbers refer to like elements throughout. In the figures, certain layers, regions, or components may be exaggerated or enlarged for clarity.

15 The terminology used in the description of the invention herein is for the purpose of describing particular embodiments only and is not intended to be limiting of the invention. As used in the description of the invention and the appended claims, the singular forms "a", "an" and "the" are intended to include the plural forms as well, unless the context clearly indicates otherwise.

20 Unless otherwise defined, all technical and scientific terms used herein have the same meaning as commonly understood by one of ordinary skill in the art to which this invention belongs. All publications, patent applications, patents, and other references mentioned herein are incorporated by reference in their entirety. The term "tissue," as used herein, can include cells, organs, bodily fluids, and other biological matter in a biological sample or the body of a
25 subject. For example, the term tissue can be used to describe cells, organs and/or other biological matter in a human body. The term "biomolecule" can include tumor specific antigens (TSA), such as proteins associated with particular types of tumor cells. It will be understood that the present invention may be used for *in vivo* use or for *ex vivo* use. It will also be understood that the term "*in vivo*" is specifically intended to encompass *in situ*
30 applications.

In a preferred embodiment of the present invention, biomolecules (e.g., antigens) associated with hyperproliferative cells (including tumors, cancers, and neoplastic tissue, along with pre-malignant and non-neoplastic or non-malignant hyperproliferative cells) are detected. The term "tumor" is generally understood in the art to mean an abnormal mass of

undifferentiated cells within a multicellular organism. Tumors can be malignant or benign. Preferably, embodiments of the inventions disclosed herein are used to detect biomolecules associated with malignant tumors. Examples of tumors, cancers, and neoplastic tissue associated with the biomolecules that can be detected by embodiments of the present invention include but are not limited to malignant tumors such as breast cancers; osteosarcomas; angiosarcomas; fibrosarcomas and other sarcomas; sinus tumors; ovarian, ureteral, bladder, prostate and other genitourinary cancers; colon esophageal and stomach cancers and other gastrointestinal cancers; lung cancers; myelomas; pancreatic cancers; liver cancers; kidney cancers; endocrine cancers; skin cancers; and brain or central and peripheral nervous (CNS) system tumors, malignant or benign, including gliomas and neuroblastomas. Biomolecules associated with premalignant and non-neoplastic or non-malignant hyperproliferative tissue include but are not limited to biomolecules associated with myelodysplastic disorders; cervical carcinoma-in-situ; familial intestinal polyposes such as Gardner syndrome; oral leukoplakias; histiocytoses; keloids; hemangiomas; psoriasis; and cells made hyperproliferative by viral infections (e.g., warts).

Although the present invention is described herein with reference to the detection of antigens associated with tumor and other hyperproliferative cells, the present invention may also be utilized for the measurement of glucose, cell necrosis byproducts, cell signaling proteins, and the like.

The embodiments of the present invention are primarily concerned with use in human subjects, but the embodiments of the invention may also be used with animal subjects, particularly mammalian subjects such as primates, mice, rats, dogs, cats, livestock and horses for veterinary purposes, and for drug screening and drug development purposes.

As used herein, the term "optical radiation" can include radiation that can be used to transmit signals in tissue, such as radiation in the visible, ultraviolet, infrared and/or other portions of the electromagnetic radiation spectrum.

Although the embodiments described herein refer to fluorescently labeled binding molecules (i.e., antibodies), it will be understood that the present invention may be used with any type label, including fluorescent labels (e.g., fluorescein, rhodamine), radioactive labels (e.g., ³⁵S, ¹²⁵I, ¹³¹I), bioluminescent labels (e.g., biotin-streptavidin, green fluorescent protein (GFP)), and enzyme labels (e.g., horseradish peroxidase, alkaline phosphatase).

It will also be understood that while embodiments described herein refer specifically to antibodies, the present invention may also be used with other molecules that bind the biomolecules to be detected. Furthermore, although the present invention is described with

reference to detecting concentrations of antigens, the present invention may also be used to detect the concentration of any biomolecules whose detection is desired, including but not limited to proteins, polypeptides, nucleic acids, polysaccharides, and the like.

As used herein, the term "antibody" is understood to encompass all antibodies as that term is understood in the art, including but not limited to polyclonal, monoclonal, chimeric, and single chain antibodies, Fab fragments, and fragments produced by a Fab expression library. Monoclonal antibodies may be prepared using any technique which provides for the production of antibody molecules by continuous cell lines in culture. These include, but are not limited to, the hybridoma technique, the human B-cell hybridoma technique, and the EBV-hybridoma technique. See, e.g., G. Kohler et al. (1975) *Nature* **256**, 495-497; D. Kozbor et al. (1985) *J. Immunol. Methods* **81**, 31-42; R. J. Cote et al. (1983) *Proc. Natl. Acad. Sci. USA* **80**, 2026-2030; and S. P. Cole et al. (1984) *Mol. Cell Biol.* **62**, 109-120.

Chimeric antibodies may be produced according to methods set forth in, for example, S. L. Morrison et al. (1984) *Proc. Natl. Acad. Sci.* **81**, 6851-6855; M. S. Neuberger et al. (1984) *Nature* **312**, 604-608; and S. Takeda et al. (1985) *Nature* **314**, 452-454). Alternatively, techniques described for the production of single chain antibodies may be adapted, using methods known in the art, to produce antigen-specific single chain antibodies. Antibodies may also be produced by inducing in vivo production in the lymphocyte population or by screening immunoglobulin libraries or panels of highly specific binding reagents as disclosed in the literature. See, e.g., R. Orlandi et al. (1989) *Proc. Natl. Acad. Sci.* **86**, 3833-3837; and G. Winter et al. (1991) *Nature* **349**, 293-299. Antibodies with related specificity, but of distinct idiotypic composition, may be generated by chain shuffling from random combinatorial immunoglobulin libraries. See e.g., D. R. Burton (1991) *Proc. Natl. Acad. Sci.* **88**, 11120-11123).

Antibody fragments which contain specific binding sites for antigens can also be used. For example, such fragments include, but are not limited to, the F(ab')₂ fragments which can be produced by pepsin digestion of the antibody molecule and the Fab fragments which can be generated by reducing the disulfide bridges of the F(ab')₂ fragments. Alternatively, Fab expression libraries may be constructed to allow rapid and easy identification of monoclonal Fab fragments with the desired specificity. See W. D. Huse et al. (1989) *Science* **254**, 1275-1281.

Fluorescence-based assays are well established for *ex vivo* studies and a number of fluorophores and tagged antibody systems are commercially available. An extensive list of commercially available pH-dependent fluorophores useful in the practice of the present

invention can be found in R. P. Haugland, Chapter 23 ("pH Indicators") of *Handbook of Fluorescent Probes and Research Chemicals, Sixth Edition* (Molecular Probes, Inc. Eugene, Oregon, (1996), and HTML version located at www.probes.com).

According to embodiments of the present invention, fluorescently labeled binding molecules, such as antibodies, can be bound to biomolecules, such as antigens, associated with tumor cells. An optical radiation source can be used to excite the fluorescently labeled antibodies bound to the antigens. The fluorescently labeled antibodies emit a second optical radiation in response to the excitation. A sensor can be used to detect a level of the optical radiation emitted by the fluorescently labeled antibodies. The level of emitted optical radiation can be used to determine the concentration of antigens present. The concentration of antigen may then be correlated to the amount, or the presence, or the growth or proliferation behavior of the tumor cells based on known relationships between concentration of tumor specific antigen and these parameters, or according to relationships that may be determined by the skilled artisan.

FIG. 1 is a schematic illustration of embodiments according to the present invention that can be used to determine antigen levels of *in vivo* tumor tissue **110**. The tumor tissue **110** may be characterized by a type of tumor specific antigen (TSA) **195** located at the surface **100** of the tumor tissue **110**. For example, a TSA **195** may be found on the surface of cell tissue **110**. In general, suitable biomolecules (*i.e.*, TSAs) indicative of tumor cell proliferation are essentially independent of many of the biological, physiological, and/or environmental properties that are found in solid tumors. Although only a single surface of tissue **110** is shown, it will be understood that embodiments according to the present invention may be utilized to detect biomolecule concentrations for a plurality of tissue **110**.

The phase of the tumor tissue **110** may be detected based on a concentration level of the TSA **195** at the surface **100**. For example, a "growth" phase of the tumor may be characterized by relatively high concentrations of the TSA **195** and a "remission" phase may be characterized by relatively low concentrations of TSA **195**.

A platform **105** is located *in vivo* proximate to the tumor tissue **110** and may or may not become bio-fouled with a bio-fouling tissue **190** over time. The platform **105** carries a matrix material **140** that can include fluorescently labeled antibodies **130** that are suspended in the matrix material **140**. The matrix material **140** can be soluble so that the fluorescently labeled antibodies **130** can be released from the matrix material **140** over time. The matrix material **140** can be in the shape of a cylinder as shown, for example, in **FIGS. 3** and **4**.

Other shapes may be used. The platform 105 can also include a telemetry system that transmits and receive signals to and from systems which are *ex vivo*.

The fluorescently labeled antibodies 130 are selected to specifically interact or bind with the TSA 195 that characterizes the tumor tissue 110, but is not associated with normal tissue. More than one TSA 195 may characterize a the tumor tissue 110. When the
5 fluorescently labeled antibodies 130 are released from the matrix material 140, some of the fluorescently labeled antibodies 130 bind with the TSA 195 on the surface 100 proximate to the platform 105 to form a binding complex 160. The unbound fluorescently labeled antibodies 150 may dissipate over time to become remote from the platform 105.

10 An optical radiation source 120 emits a first optical radiation 170 that excites the fluorescent labels of the binding complexes 160 to a higher energy state. In one embodiment of the invention, the first optical radiation is emitted through a biofouling tissue 190. Once excited, the fluorescent labels of the bound complexes emit a second optical radiation 180. The respective wavelengths of the first optical radiation 170 and the second optical 180 may
15 be selected to promote penetration of the bio-fouling tissue 190. The optical radiation source can be, for example, a laser diode, a high power Light Emitting Diode (LED), or the like, as described further herein.

An optical radiation detector 115 can detect the second optical radiation 180 through bio-fouling tissue 190 thereby avoiding some of the drawbacks associated with conventional
20 techniques. A time interval between the emission of the first optical radiation 170 and detection of the second optical radiation 180 can be selected to allow the fluorescently labeled antibodies 130 to bind with the TSA 195 on the surface 100. The optical radiation detector 115 can be a photodiode or a phototransistor. Other devices as described further herein and/or known to those skilled in the art and may be also be used.

25 The optical radiation detector 115 can include an optical absorption filter to reduce the effects of background noise. The optical radiation source 120 and the optical radiation detector 115 can be separated by a shield that reduces the amount of the first optical radiation 170 that reaches the optical radiation detector 115. In some embodiments, the optical
30 radiation detector 115 is located about 500 micrometers from the bound complexes 160. In other embodiments, the optical radiation detector 115 includes a lens that collects and focuses the second optical radiation 180 so that the separation between the optical radiation detector 115 and the bound complexes 160 may be increased.

The intensity of the second optical radiation 180 can be used to determine the concentration of the TSA 195. In particular, the TSA 195 that is proximate to the platform

105 may have fluorescently labeled antibodies 130 bound thereto. Accordingly, the fluorescent labels may emit the second optical radiation 180 after the excitation of the first optical radiation 170.

FIG. 2 is a schematic illustration of embodiments according to the present invention.

5 According to FIG. 2, a platform 200 can be located *in vivo* proximate to tissue 290 that includes antigens 205. A bio-fouling tissue 225 may develop on portions of the platform 200 over time. The platform 200 can include first and second matrix materials 240 and 215, respectively. The first matrix material 240 can include unlabeled antibodies 220. The second matrix material 215 can include fluorescently labeled antibodies 210. In some embodiments, 10 additional matrix materials can be used. As described herein, the matrix materials may include different concentrations of antibodies and/or mixtures of antibodies wherein some antibodies may be labeled and others may not be labeled.

The unlabeled and fluorescently labeled antibodies 220, 210 can be released continuously over time or in phases as described herein. The release of the respective 15 antibodies may be out of phase with respect to each other. For example, unlabeled antibodies 220 may be released during a first time interval and the fluorescently labeled antibodies 210 may be released during a second time interval. The antibodies may also be released using an apparatus 270 coupled to the respective matrix material, as described further herein. The apparatus 270 coupled to each matrix material may be different. In some embodiments, the 20 apparatus 270 may be used to control the rate of release of the unlabeled and/or labeled antibodies. The use of a controlled release strategy can be employed to provide a continuous source of fluorescently-labeled antibody 230, which can be advantageous in the dynamic biological environment in which the platform 200 must function.

The unlabeled antibodies 220 are released into the tissue 290 to provide free 25 unlabeled antibodies 235. The fluorescently labeled antibodies 210 are released to provide free fluorescently labeled antibodies 230. Some of the free fluorescently labeled antibodies 230 bind to the antigens 205 to provide bound antigens 231. Some of the bound antigens 231 become bound to the unlabeled antibodies 220 at the surface of the second matrix material 240 to provide bound structures 290 at the surface of the second matrix material 240. An 30 optical radiation emitter/detector 285 is adjacent to the second matrix material 285 and can be used to excite the bound structures 290 and detect a signal as discussed above.

FIG. 3 is a schematic illustration of compositions of matter according to the present invention. According to FIG. 3, fluorescently labeled antibodies 330 are released from a matrix material 335 over time. The matrix material can be selected based on factors such as

biocompatibility, time release characteristics, degradation, interaction with the fluorescently labeled antibodies 330 suspended therein, lack of autofluorescence, etc.

It will be understood that other fluorescently labeled antibodies may be included in the matrix material 335 to provide a mixture of different types of antibodies. The term
5 "different types of antibodies" will be understood to mean that one type of antibody may have more than kind of label, *i.e.*, label A and label B. Alternatively, more than one type of antibody (*i.e.*, antibody A and antibody B) may have the same label. For example, the matrix material 335 can include type A and type B fluorescently labeled antibodies 330. Moreover, the A and B type fluorescently labeled antibodies 330 may have different concentrations. For
10 example, the A type fluorescently labeled antibodies 330 can comprise 20% of the fluorescently labeled antibodies 330 and the type B fluorescently labeled antibodies 330 can comprise 80% of the fluorescently labeled antibodies 330. Additional types of fluorescently labeled antibodies 330 may also be included in varying concentrations.

It is preferable that the matrix material 335 not react with or damage the fluorescently
15 labeled antibodies 330 suspended therein. It is also preferable that the matrix material 335 not promote bio-fouling at the interaction surface 340 so that the fluorescently labeled antibodies 330 may be released over time without undue interference. The matrix material 335 may comprise one or more of several polymers. The choice of polymer can be determined empirically as encapsulation, degradation and release characteristics of polymers
20 in tissue may vary from subject to subject, or from cell type to cell type, or from sample to sample, and the like. Suitable biodegradable polymers can be based on hydrolysis of ester linkages in the polymer, and a variety of polymers of this type are commercially available and well characterized. Many of these polymers degrade into small, non-toxic molecules. Some of the most common biodegradable polymers are poly(lactic acid) and poly(glycolic
25 acid). Fried, Joel R. Polymer Science and Technology, Englewood Cliffs, NJ, Prentice Hall, 1995, pp. 246-249. In some embodiments according to the present invention, the matrix material 335 is a mixture of different materials such as a combination of polylactic acid and polyglycolic acid. The different materials can occur in a range of concentrations. For example, the matrix material 335 can comprise between about 0 and about 50% polylactic
30 acid and/or between about 10 and about 50% polyglycolic acid.

In some embodiments, time release of the fluorescently labeled antibodies 330 may be controlled by selecting the matrix material 335 based on the biocompatibility of the material 335 with the antibody or biomolecule to be detected, polymer type, polymer structure (*e.g.*,

the physical size and porosity of the polymer release bead), the molecular weight of the matrix material 335, the porosity of the matrix material 335, and/or other material parameters.

In other embodiments, the matrix material 335 may be coupled to an apparatus 350 that can affect the rate at which the matrix material 335 releases the fluorescently labeled antibodies 330. For example, the apparatus 350 can be a piezoelectric circuit that vibrates the matrix material 335, thereby causing the fluorescently labeled antibodies 330 to be released at varying rates. Although several parameters (*e.g.*, polymer structure, molecular weight, porosity, etc.) are available to control the rate and time course of release, other techniques for controlling release may be used. For example, the polymer may be mounted on top of a piezoelectric element, whereby the actuation of the element (*e.g.*, mechanically shaking the polymer with a sinusoidal input to the piezoelectric) increases the rate of release. Another option for modulating release rate is to blend the matrix material 335 with an electrically conducting polymer (*e.g.*, polypyrrole) and, by oxidizing and reducing the polymer electrochemically, modulate the porosity of the blend (Kontturi et al., "Polypyrrole as a model membrane for drug delivery", *Journal of Electroanalytical Chemistry*, 1998, 453(1-2), 231-238, Hepel, M. et al., "Application of the electrochemical quartz crystal microbalance for electrochemically controlled binding and release of chlorpromazine from conductive polymer matrix", *Microchemical Journal*, 1997, 56, 54-64, Yano, S. et al., "Extracellular release of a recombinant gene product by osmotic shock from immobilized microalga in electroconductive membrane" *Bioelectrochemistry and Bioenergetics*, 1996, 39, 89-93, Bidan et al., "Incorporation of Sulfonated Cyclodextrins into Polypyrrole – An Approach for the Electro-controlled delivering of Neutral-Drugs", *Biosensors & Bioelectronics*, 1995, 10, 219-229, Hepel, M. et al., "Electrorelease of Drugs from Composite Polymer-Films" *ACS Symposium Series*, 1994, 545, 79-97.

FIG. 4 is a schematic illustration of compositions of matter according to the present invention. According to **FIG. 4**, fluorescently labeled antibodies 430 are released within the first, second, and third matrix material sections 435,440,445. The first and second matrix material sections 435,440 are separated by a first separator material 450 that can be devoid of the fluorescently labeled antibodies 430. The second and third matrix material sections 440,445 are separated by a second separator material 455 that can be devoid of the fluorescently labeled antibodies 430. The different matrix material sections can provide for "pulses" of labeled material to be released at different times. In particular, after a barrier dissolves, the underlying matrix section can provide for a pulsed release of the labeled antibody. This could be used, for example, to measure a level of antigen expression over

time. Moreover, the first, second, and third matrix materials sections 435,440,445 can each have different compositions of fluorescently labeled antibodies 430 to provide different rates of release over time.

5 **FIG. 5** is a diagram that illustrates embodiments of *in vivo* circuits and systems according to the present invention. A matrix material 530 includes the fluorescently labeled antibodies that are released in a tissue 500 as described, for example, in reference to **FIGs. 3** and 4. The matrix material 530 can be coupled to an apparatus 580 that can vary the rate of release of the fluorescently labeled antibodies as described, for example, in reference to **FIGs. 3** and 4.

10 An optical radiation source 505 can include an amplifier that responds to a control input A to provide an output current that passes through a high power light emitting diode that emits optical radiation 515. The optical radiation 515 can pass through a bio-fouling tissue 570 and excite the fluorescent labels on the fluorescently labeled antibodies.

15 The excited fluorescent labels can emit an optical radiation 520 that can pass through the bio-fouling tissue 570 to reach an optical radiation detector 510. For example, the optical radiation 520 impinges a photodetector. In response, the photodetector can generate a current that can be converted to a voltage level that represents the level of the optical radiation 520. In some embodiments according to the present invention, the photodetector is a photomultiplier. The optical radiation detector 510 can include an absorption filter to reduce background noise.

20 The optical radiation source 505, the optical radiation detector 510, and the matrix material 530 can operate in conjunction with a processor circuit 525. The processor circuit 525 can control the release of the fluorescently labeled antibodies from the matrix material 530 by controlling the apparatus 580 that, for example, vibrates the matrix material 530 to vary the rate of release of the fluorescently labeled antibodies.

The processor circuit 525 can provide an input to the optical radiation source 505. The processor circuit 525 can monitor an output signal C from the optical radiation source 505 to determine, for example, the power output thereof. Other functions may be monitored and/or controlled.

30 The processor circuit 525 can receive a voltage level B from the optical radiation detector 510 to determine, for example, the intensity of the optical radiation 520. The processor can provide an output E to a telemetry system (526). The telemetry system 526 can transmit/receive data to/from an *ex vivo* system (not shown). The *ex vivo* system can control the release of the fluorescently labeled antibodies by transmitting a signal into the

body for reception by the *in vivo* system. The *in vivo* system can release fluorescently labeled antibodies in response to the signal from the *ex vivo* system. Other signals can be transmitted from the *ex vivo* system. In some embodiments, the transmitted/received data is digitally encoded. Other types of data transmission may be used.

5 The *in vivo* system can transmit data to the *ex vivo* system. For example, the *in vivo* system can transmit data associated with the intensity of the optical radiation 520. The *in vivo* system can transmit other data to the *ex vivo* system. Accordingly, the *in vivo* system can be implanted for *in vivo* use whereby the *ex vivo* system can control operations of the *in vivo* system including receiving data from the *in vivo* system without an associated invasive
10 procedure.

In some embodiments, the *in vivo* system is powered remotely through the tissue in which it is implanted. For example, the *in vivo* system can include an inductor that provides power to the *in vivo* system via an inductively coupled power signal from the *ex vivo* system. In some embodiments, the *in vivo* system has a diameter of approximately 2 mm.

15 In the embodiments of the invention described above, a light emitting diode (LED) or laser diode (for greater excitation intensity) can be used as the excitation source and a photodiode can be used to detect the corresponding emission signal. Integral emission and absorption filters can be introduced as needed in the form of dielectric coatings on the diode elements. Light emitting diodes, and photodetectors are now commonly available. These
20 devices can be extremely compact, with a laser diode being typically less than 100 μm . Thin film deposition and fiber optic technologies known to the skilled artisan permit the construction of extremely sharp optical filters.

An external sensor package for the optical implant apparatus described above may be about 2 mm x 10 mm in the form of a rounded cylinder. This configuration may ease
25 insertion into a subject when used in conjunction with a device similar to a biopsy needle. The standardization of package size and geometry may enable a diverse range of coatings such as diamond like carbon (DLC) or glasses of various compositions and plastics. The inner portion of the package can be used to provide a hermetic seal isolating the device from the effects of moisture and attack by the body.

30 In some embodiments, laser diodes are mounted on a heat sink and emit light from front and rear facets perpendicular to the circuit board. The optical power from the rear facet can be measured by a photodetector mounted on the opposite side of the circuit board. This permits feed back control of the optical power. On one side of the optical barrier dividing the

cylinder, a signal photodiode receives the return fluorescence or the absorption signal to be ratioed, as in the case of oxygen measurements. An optical rejection filter can be deposited on the photodetector to reduce background noise. The telemetry coil, drivers and other electronics can be distributed on either side of the circuit board.

5 The embodiments of the invention described herein may afford effective baseline correction, a potentially important consideration in the practice of the present invention. Changes in diode laser output as a function of time can be accommodated through the use of standard photodiode feedback techniques. Measurements before and after insertion can be used to provide an initial baseline. This may be helpful in assessing background fluorescence
10 and the degree of non-specific binding. The influence of external lighting as a parameter may also be assessed. The lifetime of the implant may be as long as six months or even more in some cases.

 One advantage of this detection scheme is that it may be relatively resistant to the accretion of material on the outer surface of the sensor ("biofouling"). One aspect of the
15 invention provides for emission and absorption wavelengths through whatever over layer covers the sensor surface. Although close proximity of the target fluorophore to the sensor is desirable, significant leeway is obtained for detection of signals away from the site of sensor implantation. As discussed herein, one embodiment includes a time-released, tagged
20 antibody or event-activated hybridization reaction. Continuous monitoring of the implanted sensor is possible so that kinetics of the reaction can also be assessed.

 In embodiments of the present invention, a lens system may or may not be present, but the detector is preferably placed in close proximity (*e.g.*, about 500 micrometers) to the source of fluorescence. In this way, the detector may become the image plane. The sensor
25 may alternatively be non-imaging and accordingly may be used as a binary-state detector for the presence or absence of fluorescent signal.

 As disclosed above, according to embodiments of the present invention, fluorescently labeled antibodies can be coupled to antigens associated with tumor cells. An optical radiation source can be used to excite the fluorescently labeled antibodies coupled to the antigens. The fluorescently labeled antibodies emit optical radiation in response to the
30 excitation. A sensor can be used to detect a level of the optical radiation emitted by the fluorescently labeled antibodies. The level of optical radiation can be used to determine the concentration of antigens present on the surface of the tissue. The concentration of antigens may then be correlated to the proliferative state or growth behavior of the tissue. In the drawings and specification, typical preferred embodiments and methods according to the

2002236590 03 May 2006

- 15 -

present invention have been disclosed. Although specific terms have been used, they are used in a generic and descriptive sense only and not for purposes of limitation, the scope of the present invention being set forth in the following claims.

5 The reference in this specification to any prior publication (or information derived from it), or to any matter which is known, is not, and should not be taken as an acknowledgment or admission or any form of suggestion that that prior publication (or information derived from it) or known matter forms part of the common general knowledge in the field of endeavour to which this specification relates.

10 Throughout this specification and the claims which follow, unless the context requires otherwise, the word "comprise", and variations such as "comprises" and "comprising", will be understood to imply the inclusion of a stated integer or step or group of integers or steps but not the exclusion of any other integer or step or group of integers or steps.

2002236590 03 May 2006

- 16 -

THE CLAIMS DEFINING THE INVENTION ARE AS FOLLOWS:

1. An implantable apparatus comprising:
an optical radiation source configured for *in vivo* use to emit first optical radiation
5 to excite local fluorescently labeled binding molecules *in vivo* which are selectively bound
to target biomolecules;
an optical radiation detector configured for *in vivo* use to detect second optical
radiation emitted by fluorescence of the labeled binding molecules bound to the target
biomolecules *in vivo* in response to excitation exposure to the first optical radiation; and
10 a processor circuit, coupled to the optical radiation source and the optical radiation
detector, that controls the emission of the first optical radiation and that receives an
intensity signal associated with the intensity of the second optical radiation and transmits a
signal associated with the intensity of the second optical radiation to an *ex vivo* system.
- 15 2. An apparatus according to Claim 1 wherein the fluorescently labeled
binding molecules comprise fluorescently labeled antibodies.
3. An apparatus according to Claim 1 further comprising:
a supply of the fluorescently labeled binding molecules configured to be excited by
20 the first optical radiation, the supply being encapsulated by a material that dissolves over
time to release the fluorescently labeled binding molecules *in vivo* proximate to the target
biomolecules to which the fluorescently labeled binding molecules are configured to bind.
4. An apparatus according to Claims 1 or 3, wherein the targeted biomolecule
25 is a tumor-associated antigen and wherein the fluorescently labeled binding molecules
comprise fluorescently labeled antibodies selected to bind to the tumor-associated antigen
and not bind to other types of biomolecules.
5. An apparatus according to Claim 1, wherein the biomolecule is a sigma-2
30 receptor.

2002236590 03 May 2006

- 17 -

6. An apparatus according to Claim 1, wherein the optical radiation source emits the first optical radiation through a bio-fouling tissue.
7. An apparatus according to Claim 1, wherein the optical radiation sensor
5 detects the second optical radiation through a bio-fouling tissue.
8. An apparatus according to Claim 1, wherein the optical radiation source is selected from a group consisting of a high powered LED and a laser.
- 10 9. An apparatus according to Claim 1, wherein the optical radiation detector is selected from a group consisting of a phototransistor, a photodiode, and a photomultiplier.
10. An apparatus according to Claim 1, wherein the first optical radiation has a first frequency and the second optical radiation has a second frequency.
15
11. An apparatus according to Claim 10, wherein the first frequency is greater than the second frequency.
12. An apparatus according to Claim 1 further comprising:
20 an emission filter coupled to the optical radiation source; and
an absorption filter couple to the optical radiation detector.
13. An apparatus according to Claim 1, further comprising:
25 an inductor coupled to the processor, wherein the inductor provides power to the circuit in response to a power signal received from the *ex vivo* system.
14. An apparatus according to Claim 1, further comprising a platform having a diameter of about 2.0 mm on which the processor circuit, the optical radiation source, and the optical radiation detector are mounted.
30
15. An apparatus according to Claim 13, wherein the signal is digitally encoded

via the inductor.

16. An apparatus according to Claim 1, wherein the optical radiation source and the optical radiation detector are coated with a biocompatible optical translucent layer.
- 5 17. An apparatus according to Claim 3, wherein the supply of the fluorescently labeled binding molecules comprises:
first and second portions that include the fluorescently labeled binding molecules;
and
10 a separator portion that separates the first portion from the second portion.
18. An apparatus according to Claim 17, wherein the separator portion is less soluble in tissue than the first and second portions.
- 15 19. An apparatus according to Claim 17, wherein the first and second portions include first and second fluorescently labeled binding molecules that are different from one another.
- 20 20. An apparatus according to Claim 3, wherein the supply of the fluorescently labeled binding molecules is located on a platform with the optical radiation source, the optical radiation detector, and the processor circuit.
- 25 21. A method of monitoring/diagnosing changes in the tissue of a mammal comprising insertion of an implantable apparatus according to any one of Claims 1-20, excitation with first optical radiation of local fluorescently labeled binding molecules which are selectively bound to target biomolecules; detection of second optical radiation emitted by the fluorescence of the labeled binding molecules bound to the target biomolecules in response to excitation exposure to the first optical radiation.
- 30 22. A method according to Claim 21 wherein said mammal is a human.

2002236590 03 May 2006

- 19 -

23. A method according to Claim 21 or 22 wherein said tissue is hyperproliferative cells.

24. A method according to Claim 23 wherein said hyperproliferative cells are selected from the group consisting of tumors, cancers, neoplastic tissue, pre-malignant cells, non-neoplastic cells or non-malignant cells.

25. A method according to Claim 23 wherein said hyperproliferative cells are malignant or benign tumor cells.

26. A method according to Claim 23 wherein said hyperproliferative cells are malignant tumor cells.

27. Use of an implantable apparatus according to any one of Claims 1-20 for monitoring/diagnosing changes in the tissue of a mammal.

28. Use of Claim 26 wherein said mammal is a human.

29. Use according to any one of Claims 27-28 wherein said tissue is hyperproliferative cells.

30. Use according to Claim 29 wherein said hyperproliferative cells are selected from the group consisting of tumours, cancers, neoplastic tissue, pre-malignant cells, non-neoplastic cells or non-malignant cells.

31. Use according to Claim 29 wherein said hyperproliferative cells are malignant or benign tumor cells.

32. Use according to Claim 29 wherein said hyperproliferative cells are malignant tumor cells.

33. An implantable apparatus according to any one of Claims 1-20 or a method according to any one of Claims 21-26 or use according to any one of Claims 27-32 substantially as herein before described with reference to the Figures and/or Examples.

5 DATED this 3rd day of May, 2006

Sincel Technologies, Inc.
By its Patent Attorneys
DAVIES COLLISON CAVE

2002236590 03 May 2006

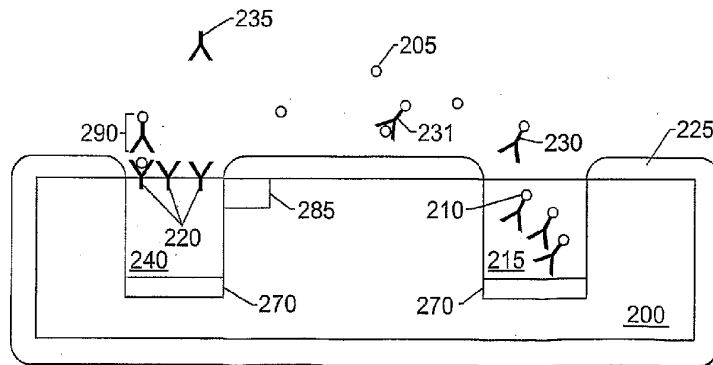
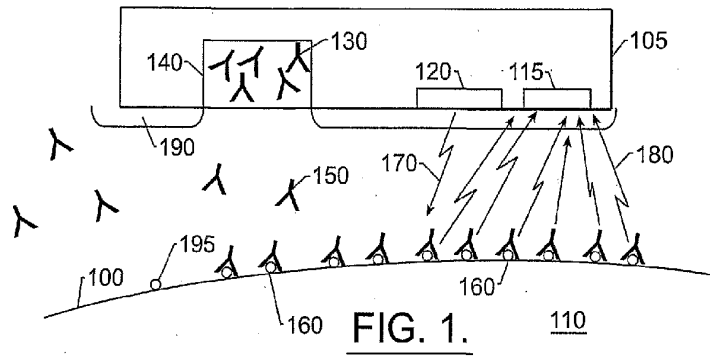

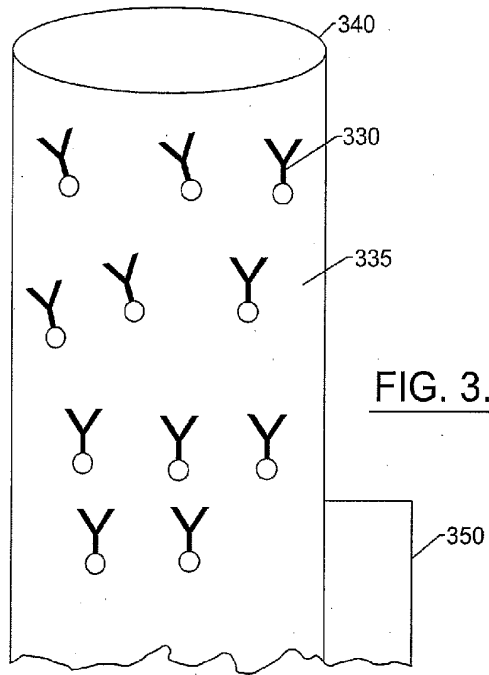

FIG. 3.

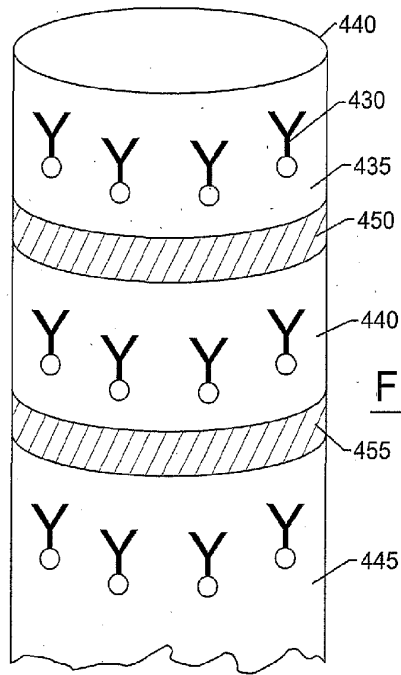

FIG. 4.

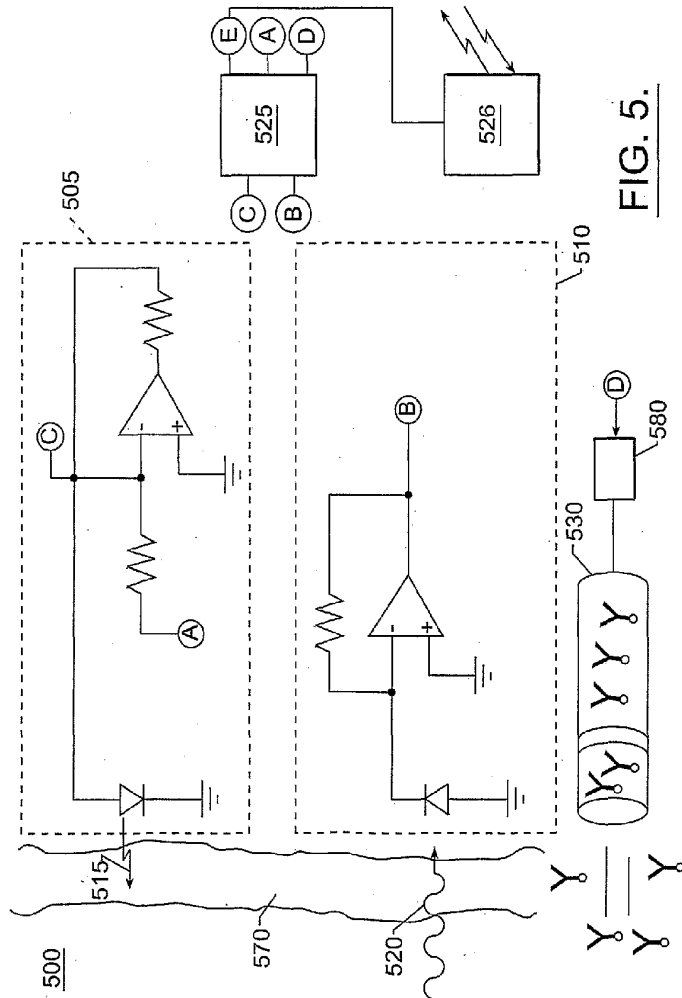

FIG. 5.