



(12) PATENT

(11) 343965

(13) B1

NORWAY

(19) NO

(51) Int Cl.

E21B 47/00 (2012.01)

E21B 47/10 (2012.01)

E21B 47/12 (2012.01)

G01V 8/02 (2006.01)

Norwegian Industrial Property Office

(21)	Application nr.	20151570	(86)	International Filing Date and Application Number	2014.07.10 PCT/US2014/046093
(22)	Date of Filing	2015.11.17	(85)	Date of Entry into National Phase	2015.11.17
(24)	Date of Effect	2014.07.10	(30)	Priority	2013.07.19, US, 13/946,341
(41)	Publicly Available	2015.11.17			
(45)	Granted	2019.07.29			
(73)	Proprietor	Halliburton Energy Services, Inc., 3000 N. Sam Houston Parkway East, TX77032 HOUSTON, USA			
(72)	Inventor	Neal G Skinner, 1219 Indian Paint Trail, TX75067 LEWISVILLE, USA			
(74)	Agent or Attorney	BRYN AARFLOT AS, Stortingsgata 8, 0161 OSLO, Norge			

(54)	Title	Modulated opto-acoustic converter
(56)	References Cited:	US 6137621 A
(57)	Abstract	

An opto-acoustic subsystem is provided. The subsystem includes an optical transmitter and an actuator device. The optical transmitter can be positioned at a surface of a wellbore. The actuator device can be positioned in the wellbore and can respond to a modulated electrical signal generated from a modulated optical signal received from the optical transmitter by outputting a modulated acoustical signal into an environment of the wellbore.

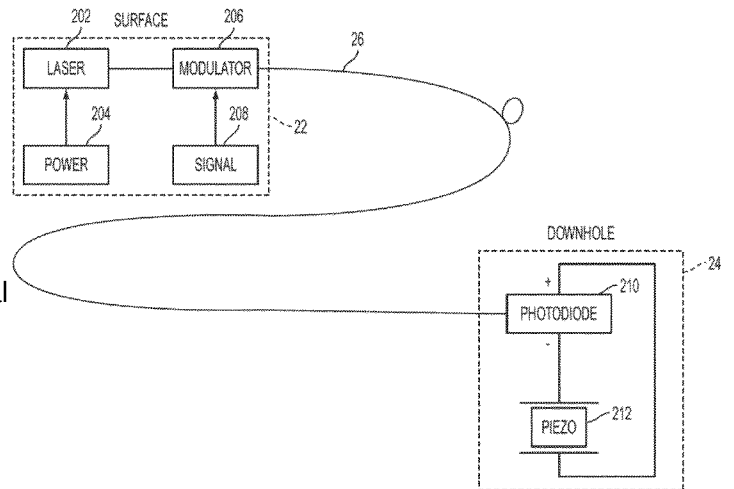

Modulated Opto-Acoustic Converter

Technical Field

[0001] The present disclosure relates generally to optically powered and controlled systems for use in a wellbore and, more particularly (although not necessarily exclusively), to downhole actuator devices for producing acoustic signals and being controlled by optical signals from surface devices.

Background

[0002] Hydrocarbons can be produced from wellbores drilled from the surface through a variety of subsurface formations. A wellbore may be substantially vertical or may be deviated. Conditions and other parameters in the wellbore can be sensed using powered devices downhole. For example, many parameters, such as pressure, temperature, fluid density, and fluid flow rate, may be sensed downhole and their values reported to the surface. Powering these devices electrically can be challenging in view of, among other things, temperature limitations of complex electronic sensors.

[0003] US 6137621 A disclose an acoustic logging system having a sonde for arranging in a borehole of a well such as an oil well. The sonde has at least one transmitter for providing at least one transmitter acoustic signal, and has receivers for responding to the at least one transmitter acoustic signal, for providing receiver signals containing information about properties of earth formations in the

borehole. The acoustic logging system features one or more transducers, a light source, an optical fiber and a detection and management unit. The detection and management unit has a signal processor, responds to the transduced optical signal, and provides a detection and management unit signal containing information about the properties of earth formations in the borehole.

[0004] The present invention comprises a downhole device, comprising:

a photodiode; and

an actuator that is responsive to a modulated electrical signal generated by the photodiode from a modulated optical signal received from an optical transmitter at a surface of a wellbore by outputting a modulated acoustical signal into an environment of the wellbore, wherein

a blocking diode (314) is disposed between the photodiode (210, 310, 410) and the actuator (212, 312, 412).

[0005] The present invention comprises further an opto-acoustic subsystem, comprising:

an optical transmitter positioned at a surface of a wellbore; and

an actuator device positioned in the wellbore and responsive to a modulated electrical signal generated from a modulated optical signal received from the optical transmitter by outputting a modulated acoustical signal into an environment of the wellbore, wherein

the actuator device includes a photodiode and a piezoelectric actuator, wherein

the actuator device further comprises a blocking diode between the photodiode and the piezoelectric actuator.

Brief Description of the Drawings

[0006] FIG. 1 is a cross-sectional schematic view of a wellbore that includes an opto-acoustic subsystem according to one aspect.

[0007] FIG. 2 is a cross-sectional schematic view of a wellbore that includes an opto-acoustic subsystem according to another aspect.

[0008] FIG. 3 is a schematic view of an opto-acoustic subsystem according to one aspect.

[0009] FIG. 4 is a schematic view of an actuator device of an opto-acoustic subsystem according to one aspect.

[0010] FIG. 5 is a schematic view of an actuator device of an opto-acoustic subsystem according to another aspect.

Detailed Description

[0011] Certain aspects and features relate to a controlled or modulated acoustic source that is downhole and that is optically powered by optical signals from the surface of a wellbore. Acoustical energy from the acoustic source can be detected and analyzed for determining downhole parameters or conditions. For example, the acoustic source may be in fluid or attached to a pipe or other tubular. Parameters of the fluid or pipe movement can be determined using a modulated acoustical signal from the acoustic source.

[0012] In some aspects, an acoustic source is a downhole actuator that can respond to a modulated optical signal received by optical fiber from an optical transmitter at the surface of the wellbore by outputting a modulated acoustical signal. For example, the downhole actuator can include a photodiode and a piezoelectric actuator. The photodiode can detect the modulated optical signal and transform it into a modulated electrical signal. The piezoelectric actuator can respond to the modulated electrical signal by outputting a modulated acoustical signal that can travel through the environment in the wellbore and be detected by a sensor in the wellbore. The sensed signal can be analyzed to determine downhole conditions or parameters.

[0013] An acoustic source according to some aspects can provide a modulated acoustical signal without requiring externally applied electric power or copper or other electrical conductors to be run from an electrical power source to the acoustic source. In some aspects, the acoustic source can be used as a component for optical downhole flow measurement, data transmission, and monitoring of the state of cure of cement, for example.

[0014] These illustrative aspects and examples are given to introduce the reader to the general subject matter discussed here and are not intended to limit the scope of the disclosed concepts. The following sections describe various additional features and examples with reference to the drawings in which like numerals indicate like elements, and directional descriptions are used to describe the

illustrative aspects but, like the illustrative aspects, should not be used to limit the present disclosure.

[0015] FIG. 1 depicts an example of a wellbore system 10 that includes an acoustic source according to one aspect. The system 10 includes a wellbore 12 that penetrates a subterranean formation 14 for the purpose of recovering hydrocarbons, storing hydrocarbons, disposing of carbon dioxide, or pumping fluid into the well for stimulation (e.g., fracturing, acidizing, etc.) of producing zones or for storage or disposal. The wellbore 12 may be drilled into the subterranean formation 14 using any suitable drilling technique. While shown as extending vertically from the surface 16 in FIG. 1, in other examples the wellbore 12 may be deviated, horizontal, or curved over at least some portions of the wellbore 12. The wellbore 12 may be cased, open hole, contain tubing, and may include a hole in the ground having a variety of shapes or geometries.

[0016] The wellbore system 10 includes a casing 18 extending through the wellbore 12 in the subterranean formation 14. A tubular 20 extends from the surface 16 in an inner area defined by the casing 18. The tubular 20 may be production tubing through which hydrocarbons or other fluid can enter and be produced. In other aspects, the tubular 20 is another type of tubing.

[0017] Some items that may be included in the wellbore system 10 have been omitted for simplification. For example, the wellbore system 10 may include a servicing rig, such as a drilling rig, a completion rig, a workover rig or other mast structure, or a

combination of these. In some aspects, the servicing rig may include a derrick with a rig floor. Piers extending downwards to a seabed in some offshore implementations may support the servicing rig. Alternatively, the servicing rig may be supported by columns sitting on hulls or pontoons (or both) that are ballasted below the water surface, which may be referred to as a semi-submersible platform, rig, or drillship. In an off-shore location, a casing or riser may extend from the servicing rig to the sea floor to exclude sea water and contain drilling fluid returns. Other mechanical mechanisms that are not shown may control the run-in and withdrawal of a workstring in the wellbore 12. Examples of these other mechanical mechanisms include a draw works coupled to a hoisting apparatus, a slickline unit or a wireline unit including a winching apparatus, another servicing vehicle, and a coiled tubing unit.

[0018] The wellbore system 10 includes an opto-acoustic subsystem that can output a modulated acoustical signal in the wellbore 12. The opto-acoustic subsystem includes an optical transmitter 22 at the surface, an actuator device 24 in the wellbore 12, and a cable 26 between the optical transmitter 22 and the actuator device 24. The cable 26 can include one or more optical fibers. In other aspects, the cable 26 is one or more optical fibers. The cable 26 may also include other types of conductors, such as electrical conductors. The cable 26 is located exterior to the tubular 20. The optical fibers may be single mode or multi-mode fiber, or multiple optical fibers can be run in parallel to supply higher optical

power than may be supplied by a single optical fiber. The optical transmitter 22 can transmit a modulated optical signal through the optical fibers in the cable 26 to the actuator device 24. The actuator device 24 can transform the modulated optical signal into a modulated electrical signal, and then output a modulated acoustical signal into an environment of the wellbore 12 using the modulated electrical signal.

[0019] The opto-acoustic subsystem can also include a receiver 30 and a line 32. The line 32 may be exterior to the tubular 20. The line 32 can include one or more sensors (not shown) that can detect the modulated acoustical signal after the modulated acoustical signal has traveled through the environment of the wellbore 12. The detected acoustical signal can be provided to the receiver 30 by the line 32. The receiver 30 can analyze the detected acoustical signal and determine a parameter or characteristics of the environment of the wellbore 12. For example, the receiver 30 may detect a fluid flow rate or the density of a fluid flowing in the wellbore 12, and the information may be used to control production in a zone of the wellbore 12. The line 32 may be any type of suitable signal conveyance. Examples of the line 32 include an optical fiber, an electrical cable, or both. The line 32 itself may detect modulated acoustical signals or it can be coupled to devices in the wellbore 12 that can detect modulated acoustical signals. The devices may convert the detected modulated acoustical signals to electrical signals, optical signals, or both, prior to transmitting signals to the receiver

30. The line 32 may contain an optical fiber, which may be itself the detector by being connected to a suitable receiver. For example, the line 32 may be connected to a receiver 30 which is a distributed acoustic sensor (DAS) unit.

[0020] In other aspects, the opto-acoustic subsystem does not include the separate line 32. The cable 26 can be used to convey signals from the wellbore 12 to components at the surface 16. Furthermore, the optical transmitter 22 and the receiver 30 can be connected to the same cable, such as to the same or different optical fibers or conductors in the cable.

[0021] Optical fibers and actuator devices according to other aspects can be positioned in wellbore locations other than the exterior of tubing. FIG. 2 depicts a wellbore system 100 according to another aspect. The wellbore system 100 is similar to the wellbore system 10 in FIG. 1. It includes a wellbore 112 through a subterranean formation 114. Extending from the surface 116 of the wellbore 112 is a casing 118 and tubular 120 in an inner area defined by the casing 118. The opto-acoustic subsystem includes an optical transmitter 122 at the surface 116 and an actuator device 124 in the wellbore 112. The actuator device 124 is communicatively coupled to the optical transmitter 122 by a cable 126. The cable 126 can include one or more optical fibers.

[0022] The cable 126 and the actuator device 124 are in an inner area defined by the tubular 120. In other aspects, the cable 126 may be hung inside the tubular 120 or spooled win and out with a winch.

The opto-acoustic subsystem also includes a receiver 130 at the surface 116 and a line 132 in an inner area defined by the tubular 120. The actuator device 124 in the inner area defined by the tubular 120 can output modulated acoustical signals according to modulated electrical signals created in the actuator device 124 from modulated optical signals received from the optical transmitter via the cable 126. The line 132 may include one or more sensors that can detect the modulated acoustical signals after the modulated acoustical signals have traveled through part of a wellbore environment. The detected signals can be conveyed to the receiver 130 for analysis.

[0023] Actuator devices according to various aspects may be located in any position in a wellbore. For example, an actuator device may be integrated in tubing. In some aspects, a wellbore includes multiple actuator devices located in multiple production zones separated by packers or other wellbore components.

[0024] FIG. 3 is a schematic diagram of the optical transmitter 22 and the actuator device 24 of FIG. 1 according to one aspect. The optical transmitter 22 is at a surface of the wellbore. The actuator device 24 is a downhole device in the wellbore.

[0025] The optical transmitter 22 includes a laser 202, a power source 204, a modulator 206, and a signal source 208. The power source 204 can provide electrical power to the laser 202. Light from the laser 202 can be modulated by the modulator 206 according to a modulation signal from the signal source 208. For example, the signal source 208 can provide a continuous wave signal and the modulator

206 can vary the output of the optical transmitter 22 according to the continuous wave signal. In other aspects, the power from the power source 204 is modulated. Any type of optical modulation technique can be used. The output of the optical transmitter 22 can be a modulated optical signal that is coupled to the cable 26. The laser output may be modulated by varying the electrical power supplied to the laser 202. Modulation may include turning power to the laser 202 on and off with a predetermined frequency or in a particular pattern such that modulator 206 may be omitted. The actuator device 24 includes a photodiode 210 and a piezoelectric actuator 212. The photodiode 210 can receive the modulated optical signal from the cable 26, which may be or include an optical fiber, and generate a modulated electrical signal from the modulated optical signal. The modulated electrical signal can cause the piezoelectric actuator 212 to generate a modulated acoustical signal in response to the modulated electrical signal that has been generated in response to the modulated optical signal received from the optical transmitter 22. For example, the piezoelectric actuator 212 can expand and contract based on a frequency of the modulated electrical signal to create a sound that is a modulated acoustical signal. The frequency of the modulated acoustical signal can correspond to the frequency of the modulated optical signal from the optical transmitter 22. In some aspects, the photodiode 210 is a stack of photodiodes and the piezoelectric actuator 212 is a stack of piezoelectric actuators, in one component. Examples of the component include a 6 volt or 12 volt photovoltaic

power converter (i.e., PPC-6 or PPC-12) from JDS Uniphase Corporation.

[0026] An actuator device according to some aspects may include additional components. FIG. 4 schematically depicts an actuator device 324 according to another aspect. The actuator device 324, which can be positioned downhole in a wellbore, includes a photodiode 310, a piezoelectric actuator 312, and a blocking diode 314. Photodiodes can be damaged by reverse bias and piezoelectric actuators can generate a voltage when deformed. The blocking diode 314 can prevent voltages, such as voltage spikes, that may be generated by the piezoelectric actuator 312 from damaging the photodiode 310.

[0027] FIG. 5 schematically depicts an actuator device 424 according to another aspect. The actuator device 424, which can be positioned downhole in a wellbore, includes a photodiode 410, a piezoelectric actuator 412, a blocking diode 414, and a resistor 416. The resistor 416 is in series with the piezoelectric actuator 412. The resistor 416 can limit the amount of current that is provided to the piezoelectric actuator. In some aspects, an actuator device can include the current-limiting resistor 416 without including the blocking diode 414.

Claims

1. A downhole device, comprising:
 - a photodiode (210, 310, 410); and
 - an actuator (212, 312, 412) that is responsive to a modulated electrical signal generated by the photodiode (210, 310, 410) from a modulated optical signal received from an optical transmitter at a surface (16) of a wellbore (12) by outputting a modulated acoustical signal into an environment of the wellbore (12),

characterized in that

 - a blocking diode (314) is disposed between the photodiode (210, 310, 410) and the actuator (212, 312, 412).

2. The downhole device of claim 1, wherein the downhole device is communicatively coupled to the optical transmitter by an optical fiber (26).

3. The downhole device of claim 1 or 2, wherein the actuator (212, 312, 412) is a piezoelectric actuator.

4. The downhole device of any of claims 1 to 3, further comprising a current limiting resistor (416) between the photodiode (210, 310, 410)

and the actuator (212, 312, 412).

5. The downhole device of any of claims 1 to 4, wherein the downhole device (24) is not supplied with electric power.

6. An opto-acoustic subsystem, comprising:

an optical transmitter (22) positioned at a surface (16) of a wellbore (12); and

an actuator device (24) positioned in the wellbore (12) and responsive to a modulated electrical signal generated from a modulated optical signal received from the optical transmitter (22) by outputting a modulated acoustical signal into an environment of the wellbore (12),

wherein

the actuator device (24) includes a photodiode (210, 310, 410) and a piezoelectric actuator (212, 312, 412),

characterized in that

the actuator device (24) further comprises a blocking diode (314) between the photodiode (210, 310, 410) and the piezoelectric actuator (212, 312, 412).

7. The opto-acoustic subsystem of claim 6, further comprising an optical fiber coupling the optical transmitter (22) and the actuator

device (24).

8. The opto-acoustic subsystem of Claim 6 or 7, wherein the opto-acoustic subsystem, further comprises a current limiting resistor (416) between the photodiode (210, 310, 410) and the piezoelectric actuator (212, 312, 412).

9. The opto-acoustic subsystem of claim 6, 7 or 8, wherein the optical transmitter includes:

a laser (202);

a power source (204) for supplying power to the laser (202);

a signal source (208); and

a modulator (206) for generating the modulated optical signal using light from the laser (202) and a signal from the signal source (208).

10. The opto-acoustic subsystem of claim 6, 7 or 8, wherein the optical transmitter includes:

a signal source (208);

a laser (202); and

a power source (204) for supplying modulated power to the laser for modulating a signal from the signal source to produce the modulated optical signal.

11. The opto-acoustic subsystem of claim 6, 7, 8, 9 or 10, further comprising:
a line extending into the wellbore (12) and coupled to a receiver that is responsive to a detected modulated acoustical signal from a sensor on the line by determining a parameter of the environment of the wellbore (12).

12. The downhole device or opto-acoustic subsystem of any preceding claim, wherein the modulated acoustical signal corresponds in frequency to the modulated optical signal.

PATENTKRAV

1. Nedihullsinnretning, omfattende:

en fotodiode (210, 310, 410); og
en aktuator (212, 312, 412) som er reagerende på et modulert elektrisk signal generert av fotodioden (210, 310, 410) fra et modulert optisk signal mottatt fra en optisk sender på en overflate (16) ved et borehull (12) ved å sende ut et modulert akustisk signal inn i en omgivelse til et borehull (12), karakterisert ved at
en blokkeringsdiode (314) er anordnet mellom fotodioden (210, 310, 410) og aktuatoren (212, 312, 412).

2. Nedihullsinnretning ifølge krav 1, hvor nedihulssinnretningen er kommunikasjonsbart koblet til den optiske senderen med en optisk fiber (26).

3. Nedihullsinnretning ifølge krav 1 eller 2, hvor aktuatoren (212, 312, 412) er en piezoelektrisk aktuator.

4. Nedihullsinnretning ifølge et hvilket som helst av kravene 1 til 3, videre omfattende en strømbegrensningsmotstand (416) mellom fotodioden (210, 310, 410) og aktuatoren (212, 312, 412).

5. Nedihullsinnretning ifølge et hvilket som helst av kravene 1 til 4, hvor nedihullsinnretningen (24) ikke er forsynt med elektrisk kraft.

6. Opto-akustisk delsystem omfattende:

en optisk sender (22) plassert ved en overflate (16) til et borehull (12); og

en aktuatoranordning (24) som er anbragt i borehullet (12) og reagerer på et modulert elektrisk signal generert fra et modulert optisk signal mottatt fra den optiske senderen (22) ved å sende ut et modulert akustisk signal in i en omgivelse til borehullet (12)

hvor

aktuatoranordningen (24) innbefatter en fotodiode (210, 310, 410) og en piezoelektrisk aktuator (212, 312, 412),

karakterisert ved at

aktuatoranordningen (24) videre omfatter en blokkeringsdiode (314) mellom fotodioden (210, 310, 410) og den piezoelektriske aktuatoren (212, 312, 412).

7. Opto-akustisk delsystem ifølge krav 6, hvor den videre omfatter en optisk fiber som kobler sammen den optiske sender (22) og aktuatoranordningen (24).

8. Opto-akustisk delsystem ifølge krav 6 eller 7, hvor det opto-akustiske delsystemet ytterligere omfatter en

strømbegrensningsmotstand (416) mellom fotodioden (210, 310, 410) og den piezoelektriske aktuatoren (212, 312, 412).

9. Opto-akustisk delsystem ifølge krav 6, 7 eller 8, hvor den optiske senderen omfatter:

en laser (202);

en strømkilde (204) for tilførsel av strøm til laseren (202);

en signalkilde (208); og

en modulator (206) for generering av det modulerte optiske signal ved bruk av lys fra laseren (202) og et signal fra signalkilden (208).

10. Opto-akustisk delsystem ifølge krav 6, 7 eller 8, hvor den optiske senderen omfatter:

en signalkilde (208);

en laser (202); og

en strømkilde (204) for tilførsel av modulert strøm til laseren for å modulere et signal fra signalkilden for å produsere det modulerte optiske signalet.

11. Opto-akustisk delsystem ifølge krav 6, 7, 8, 9 eller 10, videre omfattende:

en ledning som strekker seg inn i borehullet (12) og koplet til en mottaker som er reagerende på et detektert modulert akustisk signal fra en sensor på ledningen ved å bestemme en parameter fra

omgivelsen til borehullet (12).

12. Nedihullsinnretning eller opto-akustisk delsystem ifølge et hvilket som helst av de foregående krav, hvor det modulerte akustiske signalet korresponderer i frekvensen med det modulerte optiske signalet.

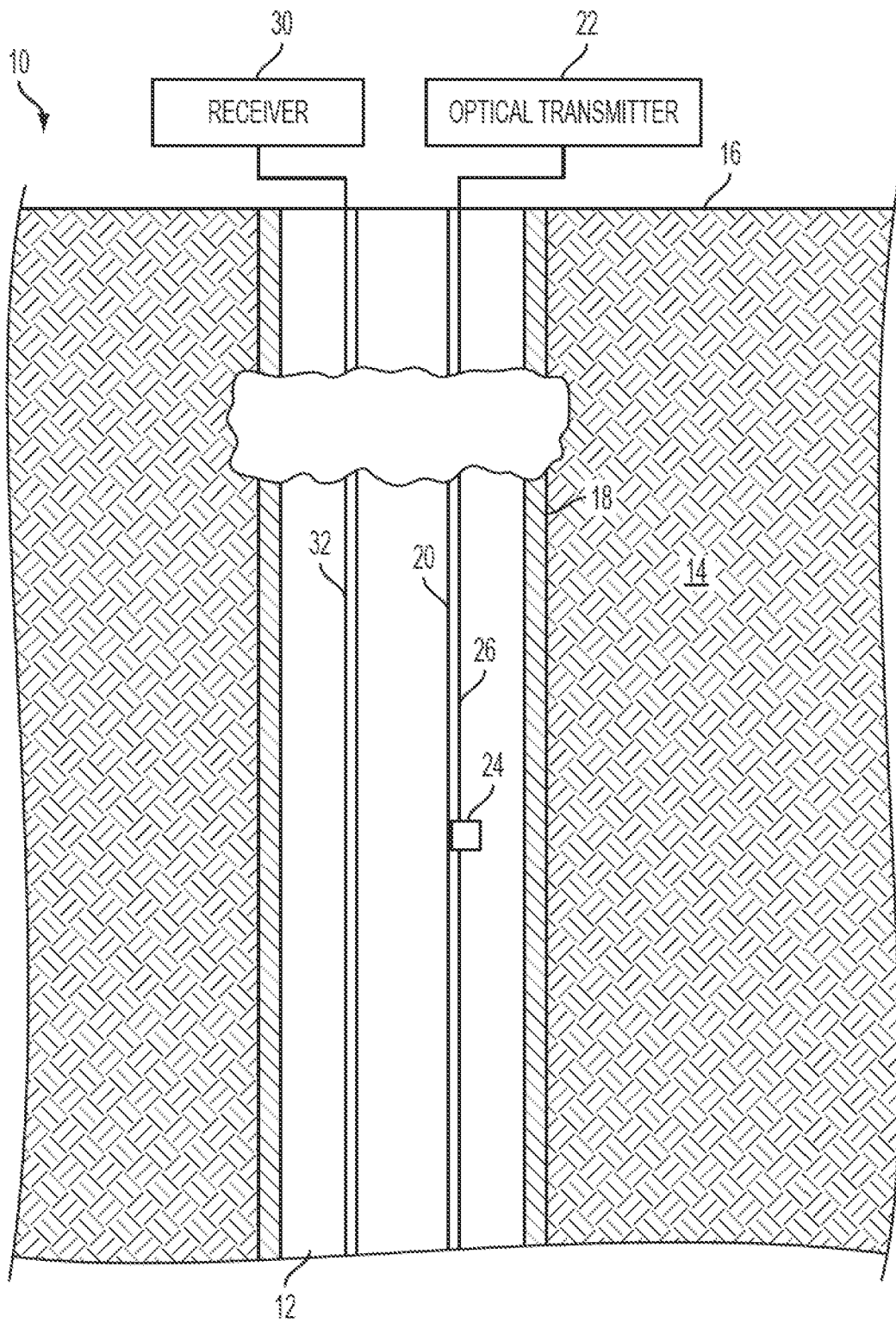

FIG. 1

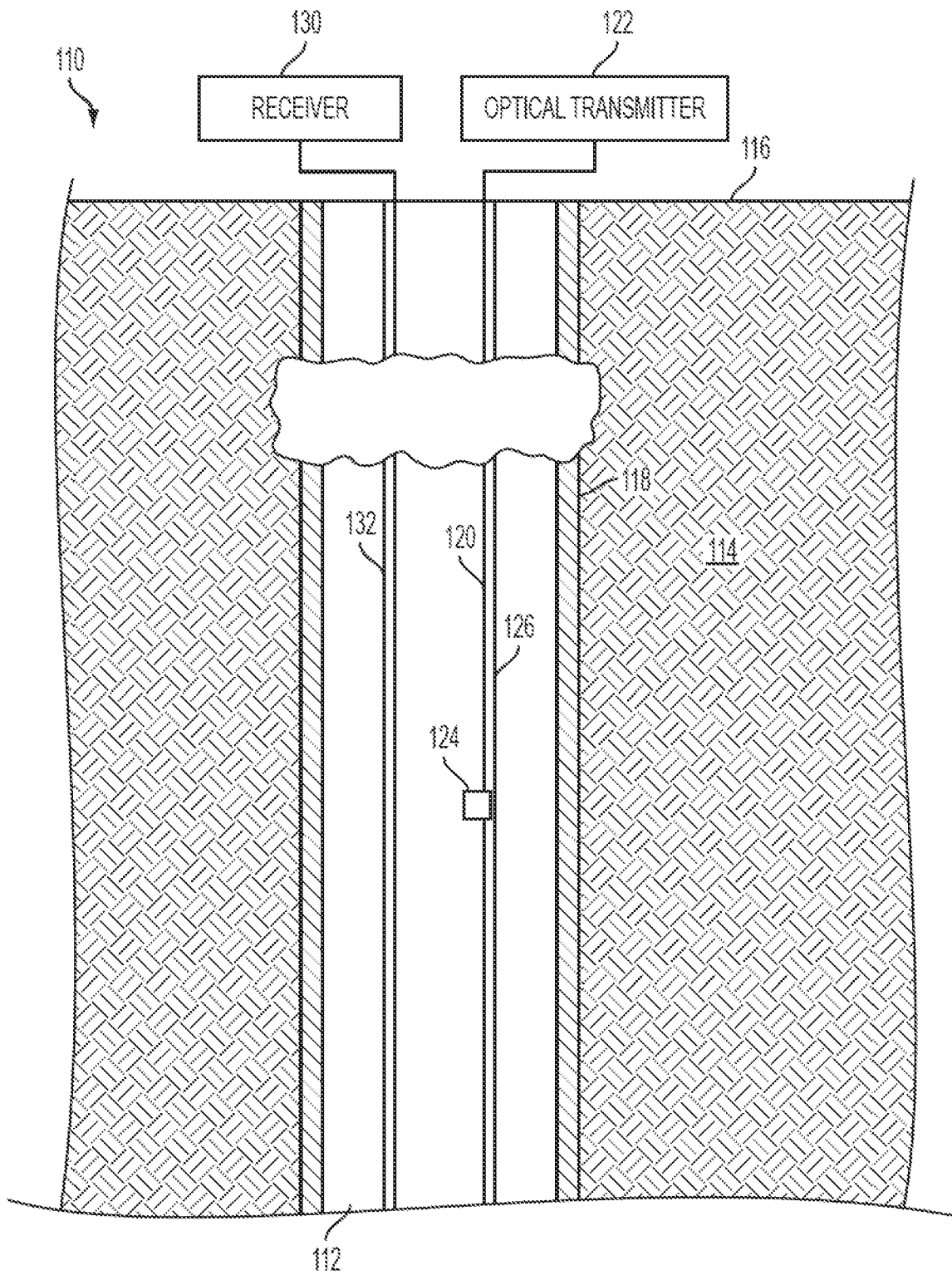

FIG. 2

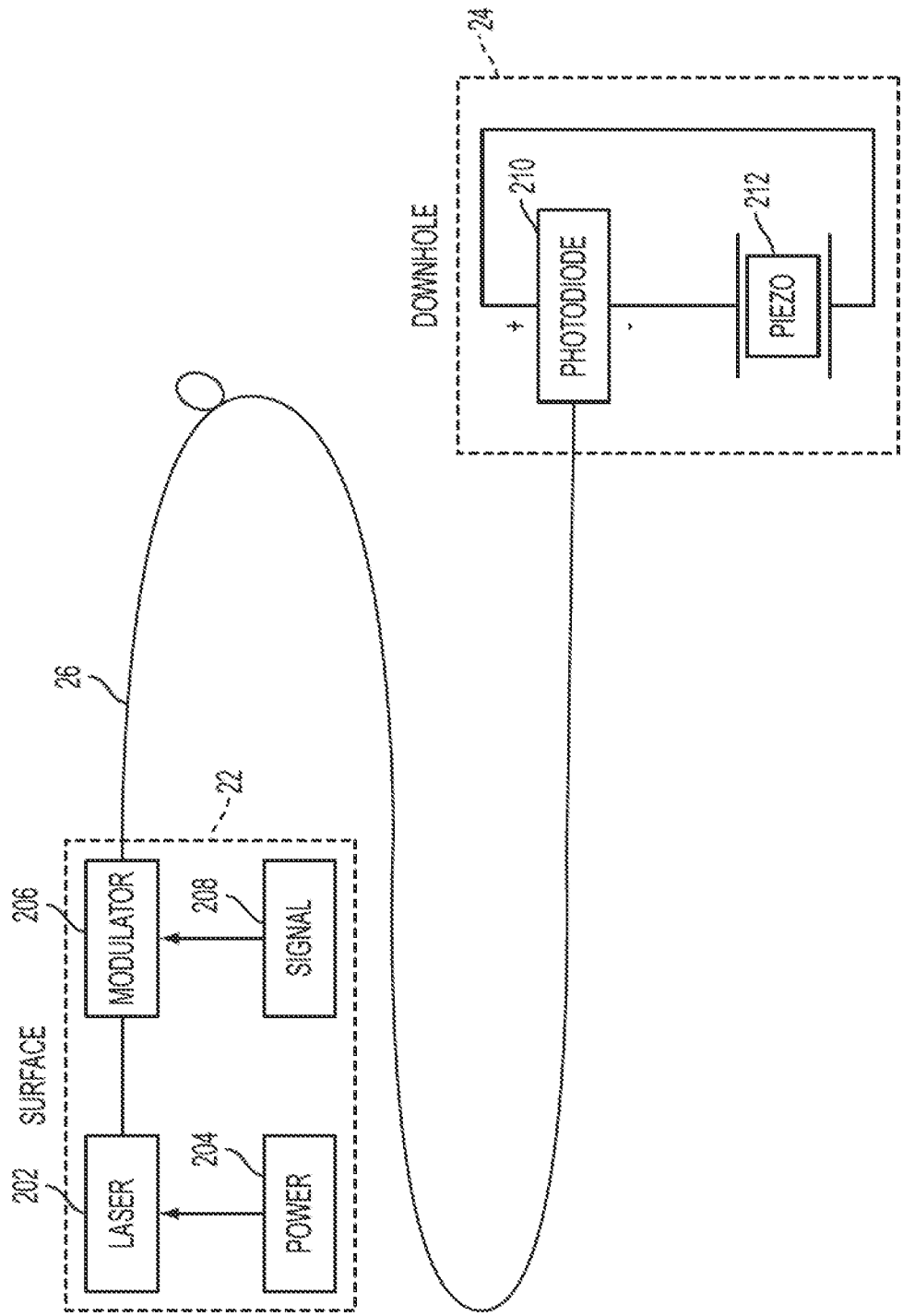

FIG. 3

4/5

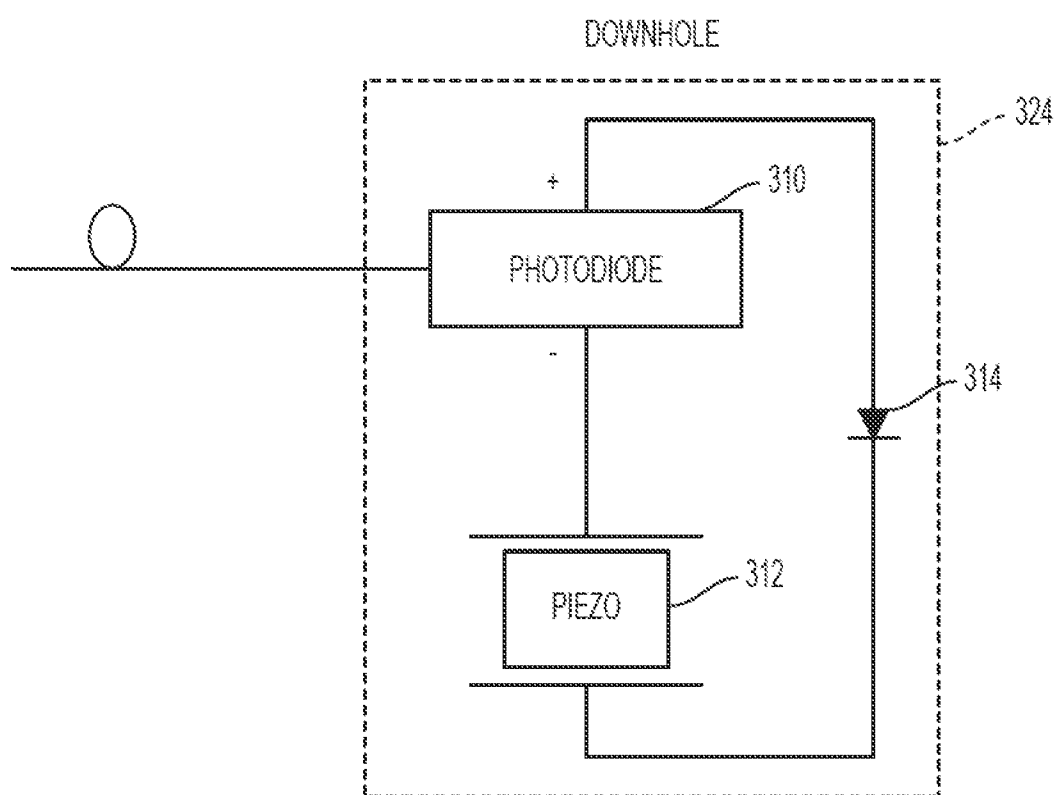

FIG. 4

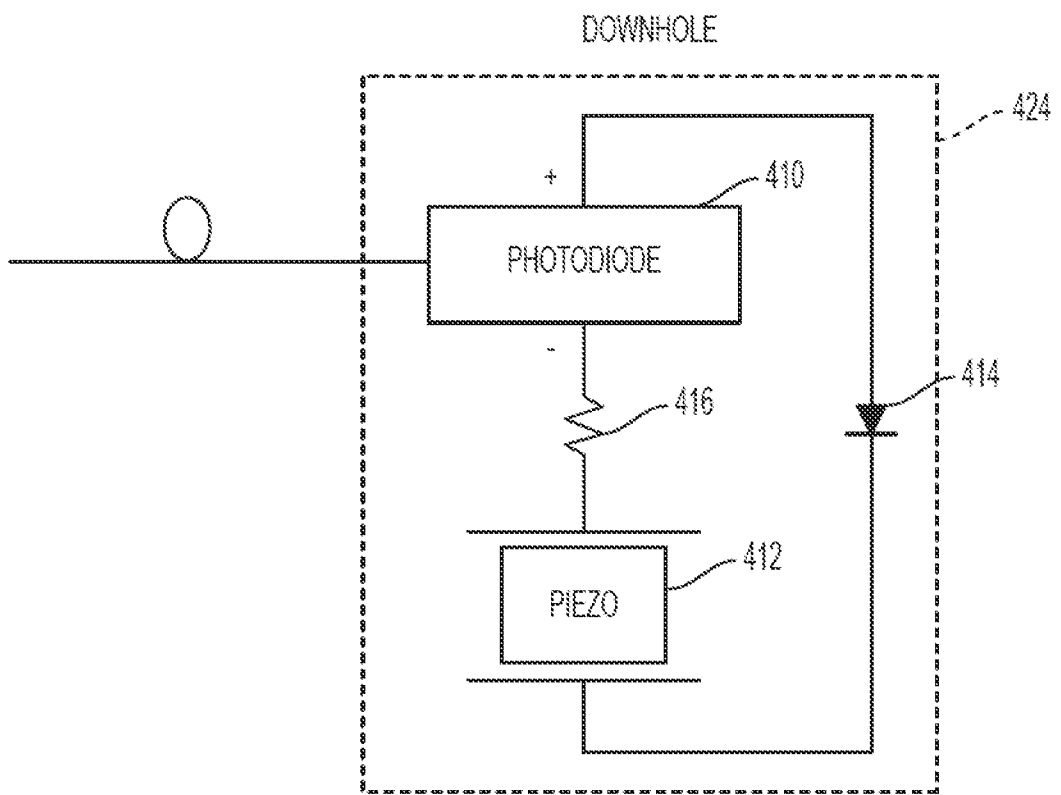

FIG. 5

INTERNATIONAL SEARCH REPORT

International application No.
PCT/US2014/046093**A. CLASSIFICATION OF SUBJECT MATTER****E21B 47/12(2006.01)i, G01V 8/02(2006.01)i**

According to International Patent Classification (IPC) or to both national classification and IPC

B. FIELDS SEARCHED

Minimum documentation searched (classification system followed by classification symbols)

E21B 47/12; G01S 13/00; E21B 43/00; G01V 1/40; G01V 1/52; G02F 2/00; H02H 3/38; G01V 8/02

Documentation searched other than minimum documentation to the extent that such documents are included in the fields searched

Korean utility models and applications for utility models

Japanese utility models and applications for utility models

Electronic data base consulted during the international search (name of data base and, where practicable, search terms used)

eKOMPASS(KIPO internal) & keywords: modulated opto-acoustic converter, optical transmitter, photodiode, piezoelectric actuator, blocking diode, and current limiting resistor

C. DOCUMENTS CONSIDERED TO BE RELEVANT

Category*	Citation of document, with indication, where appropriate, of the relevant passages	Relevant to claim No.
Y	US 2010-0025032 A1 (SMITH et al.) 04 February 2010 See paragraphs [0022], [0024]-[0026], [0033], [0043]-[0044], [0046]-[0047] and figures 1-2, 12, 15, 17-18.	1-20
Y	US 2009-0213690 A1 (STEINSIEK et al.) 27 August 2009 See paragraphs [0019], [0021]-[0023], claims 1-2, and figures 1, 3A-4.	1-20
Y	US 4375073 A (GLOGOLJA et al.) 22 February 1983 See column 3, lines 16 - column 5, line 62 and figure 3.	4-5, 12-13, 19-20
A	US 5675674 A (WEIS, R. STEPHENS) 07 October 1997 See column 8, line 12 - column 9, line 29 and figure 1.	1-20
A	US 2008-0062036 A1 (FUNK et al.) 13 March 2008 See paragraphs [0044]-[0045] and figure 3A.	1-20

 Further documents are listed in the continuation of Box C. See patent family annex.

* Special categories of cited documents:

"A" document defining the general state of the art which is not considered to be of particular relevance

"E" earlier application or patent but published on or after the international filing date

"L" document which may throw doubts on priority claim(s) or which is cited to establish the publication date of another citation or other special reason (as specified)

"O" document referring to an oral disclosure, use, exhibition or other means

"P" document published prior to the international filing date but later than the priority date claimed

"T" later document published after the international filing date or priority date and not in conflict with the application but cited to understand the principle or theory underlying the invention

"X" document of particular relevance; the claimed invention cannot be considered novel or cannot be considered to involve an inventive step when the document is taken alone

"Y" document of particular relevance; the claimed invention cannot be considered to involve an inventive step when the document is combined with one or more other such documents, such combination being obvious to a person skilled in the art

"&" document member of the same patent family

Date of the actual completion of the international search

23 October 2014 (23.10.2014)

Date of mailing of the international search report

23 October 2014 (23.10.2014)

Name and mailing address of the ISA/KR

 International Application Division
 Korean Intellectual Property Office
 189 Cheongsu-ro, Seo-gu, Daejeon Metropolitan City, 302-701,
 Republic of Korea

Facsimile No. +82-42-472-7140

Authorized officer

LEE, Jong Kyung

Telephone No. +82-42-481-3360



INTERNATIONAL SEARCH REPORT

Information on patent family members

International application No.

PCT/US2014/046093

Patent document cited in search report	Publication date	Patent family member(s)	Publication date		
US 2010-0025032 A1	04/02/2010	AU 2003-267553 A1	19/03/2004		
		AU 2003-269101 A1	19/03/2004		
		CA 2497269 A1	11/03/2004		
		CA 2497269 C	20/09/2011		
		GB 0504121 D0	06/04/2005		
		GB 0609937 D0	28/06/2006		
		GB 2409479 A	29/06/2005		
		GB 2409479 B	06/12/2006		
		GB 2426024 A	15/11/2006		
		GB 2426024 B	30/05/2007		
		US 2006-0102347 A1	18/05/2006		
		US 2007-0044672 A1	01/03/2007		
		US 7854267 B2	21/12/2010		
		WO 2004-020774 A2	11/03/2004		
		WO 2004-020774 A3	22/04/2004		
		WO 2004-020790 A2	11/03/2004		
		WO 2004-020790 A3	22/04/2004		
		US 2009-0213690 A1	27/08/2009	GB 201015088 D0	27/10/2010
				GB 2470159 A	10/11/2010
				GB 2470159 B	18/07/2012
NO 20101244 A	20/09/2010				
WO 2009-108889 A2	03/09/2009				
WO 2009-108889 A3	12/11/2009				
US 4375073 A	22/02/1983	JP 57-031229 A	19/02/1982		
US 5675674 A	07/10/1997	US 5808779 A	15/09/1998		
		US 5898517 A	27/04/1999		
US 2008-0062036 A1	13/03/2008	CA 2656647 A1	20/03/2008		
		CA 2656647 C	03/05/2011		
		US 7450053 B2	11/11/2008		
		US 7598898 B1	06/10/2009		
		WO 2008-033225 A2	20/03/2008		
		WO 2008-033225 A3	12/09/2008		
		WO 2008-033226 A2	20/03/2008		
		WO 2008-033226 A3	26/06/2008		