

(19) World Intellectual Property Organization
International Bureau



(43) International Publication Date
24 May 2007 (24.05.2007)

PCT

(10) International Publication Number
WO 2007/057331 A1

(51) International Patent Classification:
B65B 25/06 (2006.01) **B65B 35/44** (2006.01)
B65G 69/04 (2006.01)

(74) Agent: **MELLUL-BENDELAC, Sylvie**; L'AIR LIQUIDE S.A., DPI, 75, Quai d'Orsay, F-75321 Paris Cedex 07 (FR).

(21) International Application Number:
PCT/EP2006/068213

(81) Designated States (unless otherwise indicated, for every kind of national protection available): AE, AG, AL, AM, AT, AU, AZ, BA, BB, BG, BR, BW, BY, BZ, CA, CH, CN, CO, CR, CU, CZ, DE, DK, DM, DZ, EC, EE, EG, ES, FI, GB, GD, GE, GH, GM, GT, HN, HR, HU, ID, IL, IN, IS, JP, KE, KG, KM, KN, KP, KR, KZ, LA, LC, LK, LR, LS, LT, LU, LV, LY, MA, MD, MG, MK, MN, MW, MX, MY, MZ, NA, NG, NI, NO, NZ, OM, PG, PH, PL, PT, RO, RS, RU, SC, SD, SE, SG, SK, SL, SM, SV, SY, TJ, TM, TN, TR, TT, TZ, UA, UG, US, UZ, VC, VN, ZA, ZM, ZW.

(22) International Filing Date:
8 November 2006 (08.11.2006)

(25) Filing Language: English

(26) Publication Language: English

(30) Priority Data:
05300924.7 15 November 2005 (15.11.2005) EP

(84) Designated States (unless otherwise indicated, for every kind of regional protection available): ARIPO (BW, GH, GM, KE, LS, MW, MZ, NA, SD, SL, SZ, TZ, UG, ZM, ZW), Eurasian (AM, AZ, BY, KG, KZ, MD, RU, TJ, TM), European (AT, BE, BG, CH, CY, CZ, DE, DK, EE, ES, FI, FR, GB, GR, HU, IE, IS, IT, LT, LU, LV, MC, NL, PL, PT, RO, SE, SI, SK, TR), OAPI (BF, BJ, CF, CG, CI, CM, GA, GN, GQ, GW, ML, MR, NE, SN, TD, TG).

(71) Applicant (for all designated States except US): **L'AIR LIQUIDE SOCIETE ANONYME POUR L'ETUDE ET L'EXPLOITATION DES PROCEDES GEORGES CLAUDE** [FR/FR]; 75, Quai D'Orsay, F-75007 Paris (FR).

Published:
— with international search report

(71) Applicant (for DE only): **AIR LIQUIDE DEUTSCHLAND GmbH** [DE/DE]; Hans-Günther-Sohl-Strasse 5, 40235 Düsseldorf (DE).

For two-letter codes and other abbreviations, refer to the "Guidance Notes on Codes and Abbreviations" appearing at the beginning of each regular issue of the PCT Gazette.

(72) Inventor; and
(75) Inventor/Applicant (for US only): **TAYLOR, Robert** [GB/BE]; Venelle des Platanes 7, B-1300 Wavre (BE).

(54) Title: PROCESS AND APPARATUS FOR FILLING A CONTAINER WITH FOOD ARTICLES

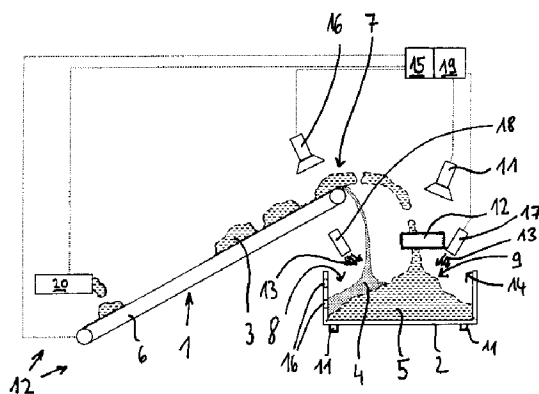

(57) Abstract: The invention concerns a process respectively an apparatus for filling a container (2) with articles (3) such as food, in particular meat, and a process respectively an apparatus for cooling articles (3) and is characterised by repeating the following steps: (A) a first portion (4) of the articles (3) is conveyed with a conveying means (6), in particular a conveyor belt, having a conveyor outlet (7) and is discharged into a container (2) at a lower conveying speed such that a first portion (4) accumulates in the container (2) at the first location (8) closer to the conveyor outlet (7); and (B) thereafter, a second portion (5) of the articles (3) is conveyed by the conveying means (6) and is discharged into a container (2) at a higher conveying speed, such that the second portion (5) accumulates in the container (2) at the second location (9) further away from the conveyor outlet (7); as well as a process respectively an apparatus for cooling articles (3) using said process and said apparatus for filling; as well as the articles processed by said processes respectively said apparatus. The control of the conveying speed allows for reducing the number of necessary surfaces of machinery with which the articles 3 come into contact. The invention effects that the articles (3) may be handled more easily in a clean way without the expense of non-uniform filling of the container. The process and the apparatus is particularly suited for homogeneously and efficiently cooling articles using carbon dioxide particles.



WO 2007/057331 A1

Process and apparatus for filling a container with food articles

The invention concerns a process respectively an apparatus for filling a container with articles such as food, in particular meat.

5

In the food industry it is frequently necessary to temporarily store food materials as an intermediate stage in the processing such as for transfer from one processing station to another or to create a buffer storage for food material to ensure that the material is continuously available at processing sites in order to achieve a smooth operation of the process.

10

In some cases it is advantageous or necessary to use this storage period to effect additional cooling of the material. Specifically for meat processing when meat is de-boned prior to further processing, during the de-boning process the meat reaches a temperature that is warmer than the optimum temperature for storage and it is stored in large transport boxes or bins in which the product can not be effectively cooled by storing the bin in a chilled environment as the heat transfer within the material is much too slow and ineffective.

15

It is well established to mix a food grade cooling medium with the product to be cooled such as to use solid carbon dioxide particles in form of preformed pellets or as carbon dioxide snow. The cooling medium is brought into contact with the product in order to achieve sufficient or additional cooling of the material. This may be effected by the manual addition of the carbon dioxide by means of adding pellets or by depositing carbon dioxide snow onto the product using "snow horns" in which the carbon dioxide snow is generated on site.

20

The cooling process may also be automated by means of a cooling device such as the one described in WO 93/14358. According to WO 93/14358 the food article is

frozen by contacting the article with a surface of a porous support which is impregnated with a cryogenic liquid, wherein the porous support may be formed as conveyor which is insulated by means of an enclosure.

5 In the food industry it is highly desirable to minimize the contact of the food products with machinery. For example, any food particles trapped in a mechanism of the machinery may lead to microbiological spoilage and contamination of the food product. It is thus desirable to design food processing equipment to have as few food contact surfaces as possible and to ensure that these are as simple and
10 easy to clean as possible.

EP 0 632 966 A1 discloses an apparatus and method for chilling a food product which includes a food distribution device having a pair of circular members including at least one spaced-apart partition defining a food receiving area; the cir-
15 cular members rotate to cause food delivered to the food product proceeding area to fall into a food storage compartment in a uniform manner; and a cryogen releasing device is connected to one of the circular members which uniformly distributes a cryogenic substance to the food product within the food storage com-
20 partment.

It is an object of the present invention to provide a process respectively an apparatus for filling a container with articles such as food, wherein the articles come into contact with surfaces of the machinery as little as possible in order to provide for easy cleanability of the machinery at the condition that full flexibility for efficient
25 cooling of the articles is maintained. It is a further object to provide for articles that have been cooled efficiently, homogenously and in an inexpensive way.

These problems are solved according to the invention by the process respectively apparatus for filling a container with articles and by the articles as defined in the

main claims. Further advantageous embodiments and favourable developments, which can be applied individually or in any desired suitable combination, are subject of the respective depending claims.

5 According to the invention, the process for filling a container with articles such as food, in particular meat, is characterized by repeating the following steps: (A) a first portion of the articles is conveyed with a conveying means, in particular a conveyor belt, having a conveyor outlet and is discharged into a container at a lower conveying speed, such that the first portion accumulates in the container at
10 a first location closer to the conveyor outlet; and (B) thereafter, a second portion of the articles is conveyed on the conveying means and is discharged into the container at a higher conveying speed, such that the second portion accumulates in the container at a second location further away from the conveyor outlet.

15 By using at least two different conveying speeds the articles are thrown respectively dropped to corresponding different locations within the container such that the container may be filled in a uniform manner. The trajectory of articles is determined by the discharge velocity vector of the respective articles at the conveyor outlet. Further contact surfaces for distributing the articles in the container such as
20 the surfaces of a rotating fan as described in the prior art are unnecessary.

In a modification of the invention the articles may be conveyed by a pivoting conveying means. The conveyor outlet of the conveying means may be movable sideways in order to deliver the articles into the container in a uniform manner. In
25 this case the conveyor outlet reciprocates from one side to the other of the container. A pivoting conveying means uses a hinge and at least two electro-motors.

The articles are supplied to the container by means of the variable speed conveyor which is normally set to operate at two speeds. At low speeds the articles are

dropped into the container in an area proximate to the conveyor outlet, i.e. at the first location. At high speeds the articles follow a trajectory and are thrown into the container in an area distal to the conveyor outlet, i.e. at the second location.

5 Once a first pile accumulating at the first location rises above a certain level, the lower conveying speed is increased to the higher conveying speed such that the articles accumulate in a second pile at the second location. Thereafter the second gradually becomes larger and larger. When the second pile exceeds a certain pre-determined limit the conveying speeds is changed to the lower conveying speed
10 again. The conveying speeds respectively the locations where the articles accumulate are repeatedly changed such that the container is filled in a uniform manner.

Uniform filling is also possible for the case that the articles enter the conveying means in an irregular way or in batches, which is common in food production,
15 where a quasi continuous product flow may be interrupted sometimes for a couple of minutes.

The conveying means may be a conveyor belt onto which the articles may be delivered using a vibrating trough.

20

The articles may be bulk goods such as ground meat or non bulk goods such as meat pieces. The process for filling the container according to the invention applies in particular to filling food articles, for which purpose special care needs to be taken with respect to the machinery and process conditions in order not to
25 introduce sources of contaminations.

Advantageously, the temperature of the articles ranges in between +0° C and +14° C, preferably between +0° C and +4° C. The temperatures also may be below

freezing point, in particular in between -30°C and -2°C , in particular in between -25°C and -18°C .

According to an embodiment of the invention the conveying speed is repeatedly
5 adjusted between at least three different speed levels in particular the conveying
speed is repeatedly varied continuously within a range of speed levels. By using
more than two speed levels it is possible to define more than two locations within
the container at which the articles accumulate. With the help of a suitable convey-
ing speed temporal profile, in particular large containers may be filled in a uni-
10 form manner.

Advantageously, the conveying speed is controlled in response to the amount of
articles being conveyed and / or being accumulated in the container. This feed-
back allows for uniform filling of the container.

15 A mass distribution of the articles within the container may be quantified using at
least two individual sensors at the container and the conveying speed may be con-
trolled in response to the quantified estimated mass distribution, in particular an
asymmetric weight profile of the container is used for controlling the conveying
20 speed. For example the container that rests on the ground with at least three, in
particular four, legs respectively wheels, is put on (at least) two weight sensors
that measure the different weights of the legs. The weight difference is used as
information about how the container is filled with articles and an asymmetry of
the filling of the container may be detected. This information may be used for
25 driving the conveying means for choosing a suitable conveying speed such that
the container is filled uniformly respectively an asymmetry of the filling is re-
duced. The mass distribution may also be quantified using a single, more complex
sensor, such as a camera (CCD) or (possibly in conjunction with the use of a cam-
era) using angled laser beams.

At least one supply port for supplying cooling medium may be controllable such that the cooling medium is repeatedly added to the first location and the second location, in particular together with the articles. The cooling medium may also be
5 added anti-cyclically that means in an alternating way to a location different to where the articles accumulate in order to create layers of cooling medium and layers of articles.

The articles may be dispersed in the container, in particular may be dispersed
10 sideways, using a deflection surface in particular a deflection surface at or above the container. The deflection surface divides the flow of articles into two parts or spreads the flow of articles such that uniform filling of the contained is achieved. The deflection surface may be fixed to the container or may be fixed to the machine frame which carries the conveying means.

15 According to the invention, the process for cooling articles such as food, in particular meat, is characterised by the process for filling according to the invention, wherein repeatedly, (A) a first portion of the articles is conveyed with a conveying means, in particular a conveyor belt, having a conveyor outlet and is discharged
20 into a container at a lower conveying speed, such that the first portion accumulates in the container at the first location closer to the conveyor outlet, and (B) thereafter a second portion of the articles is conveyed with the conveying means and discharged into the container at a higher conveying speed such that the second portion accumulates in the container in the second location further away from the
25 conveyor outlet, wherein a cooling medium, in particular liquid nitrogen or carbon dioxide particles, is added into the container. The use of carbon dioxide particles is preferred.

With help of this process the articles may be cooled uniformly in an efficient and comparatively inexpensive way without much contact to surfaces of the machinery. The cooling medium may be cold air, liquid nitrogen or carbon dioxide particles. For the case that cold air or liquid nitrogen is used a means of creating convective heat transfer, in particular a fan, is advantageous. The carbon dioxide particles may be in form of snow or in form of pellets having a diameter ranging from 1 mm to 10 mm, in particular ranging from 2 mm to 5 mm.

The cooling medium may be added into the container to come into close contact with the articles, they may also be added to the articles by means of the conveying means, in particular by discharge onto the conveyor belt.

The cooling medium is preferably food grade.

The cooling medium may be repeatedly added at the first and the second location, in particular together and simultaneously with the articles. By adding the cooling medium anti-cyclically, i. e. the cooling medium is added at the one location while the articles accumulate at the other location, the cooling medium and the articles are formed in layers.

The amount of added cooling medium may be controlled in response to the amount and/or the temperature of the articles being conveyed. For example if the articles are too warm, more cooling medium may be added, in order to cool the articles down to the desired temperature.

The amount of added cooling medium may be controlled in response to the temperature of the articles and/or respectively temperature distribution of the articles within the container. For example whenever a temperature sensor notices that the temperature somewhere in the container exceeds a predetermined level, a suitable

amount of cooling medium is added to this location. The temperature sensors may operate mechanically, electronically or optically.

According to the invention the apparatus for filling a container with articles such as food, in particular meat, comprises: the container with a receiving opening for receiving the articles, a conveying means, in particular a conveyor belt, for conveying the articles, the conveying means having a conveyor outlet and a conveyor outlet being arranged in relation to the receiving opening such that the articles discharged from the conveyor outlet enter into the container, wherein for uniformly filling the container, the conveying means is operable at at least two different conveying speeds such that, at a lower conveying speed, a first portion of the articles accumulates in the container at a first location closer to the conveyor outlet and, at a higher conveying speed, a second portion of the articles accumulates in the container at a second location further away from the conveyor outlet.

By choosing a suitable conveying speed the container may be filled in a uniform manner without the use of complicated distributing or dispersing means or complicated mechanical drives. The articles come into contact with only a few surfaces of the machinery such that the machinery may be cleaned more easily. The surfaces with which the articles come into contact may be designed to be smooth with as few gaps as possible, simple and easy to clean.

The conveying means may be operable at more than two conveying speeds, in particular the conveying speed is repeatedly available continuously within a range of different speed levels. Continuously in this respect means that the conveying speed is varied smoothly without abrupt changes, wherein the time base of the term "abrupt" is the general periodicity with which the conveying speed is changed within the range of different speed levels. The temporal profile of the conveying speed may be chosen such that the articles, which may arrive in a dis-

continuous or intermittent manner at the outlet of the conveying means, are nevertheless filled into the container such that a uniform mass distribution within the container is achieved.

- 5 Preferably a control unit for controlling uniform filling in the container is provided. The conveying means may be controlled in response to the amount of articles arriving at the conveyor outlet respectively the amount of the articles that are already discharged into the container.
- 10 Preferably, at least two sensors are provided in, at or below the container in particular separately from the container, in order to estimate the mass distribution of the articles within the container and that the conveying speed is controllable in response to the estimated mass distribution.
- 15 The mass distribution of the articles within the container may be quantified using two weight sensors that measure an asymmetric load of the container e. g. by measuring the difference in weight of the respective support feet or support wheels of the container. An asymmetric weight profile of the container may be used for controlling the conveying speed. For instance if the container comprises
- 20 four wheels (the wheels for rolling the container over ground) the weight of the two wheels close to the conveyor outlet, i.e. the weight of the proximate wheels, is compared with the weight of the two wheels opposite to the conveyor outlet, i.e. the weight of the distal wheels, and the difference is used as measure for driving the conveying means. By choosing suitable conveying speeds uniform filling of
- 25 the container is achieved.

The sensor for quantifying a mass distribution may work mechanically, electronically or optically. For example strain gauges or a CCD camera may be used.

The apparatus may comprise a deflection surface at the receiving opening of the container, in particular a deflection surface separate from the container, for dispersing the articles, in particular sideways, in the container. The deflection surface has a simple geometry in order to be cleaned easily. It may be fixed to the container.

According to the invention, the apparatus for cooling articles such as food, in particular meat, is characterised in that the apparatus for filling a container according to the invention is provided, wherein the apparatus for cooling articles further comprises a container with a receiving opening for receiving the articles, a conveying means, in particular an conveyor belt, for conveying the articles, the conveying means having a conveying outlet and the conveyor outlet being arranged in relation to the receiving opening such that the articles having been discharged from the conveyor outlet accumulate in the container, wherein for uniformly filling the container, the conveying means is operable at at least two different conveying speeds such that, at a lower conveying speed, a first portion of the articles accumulates in the container at the first location closer to the conveyor outlet and, at a higher conveying speed, a second portion of the articles accumulates in the container at a second location further way for the conveyor outlet, and further comprises at least one supply port, preferably at least two supply ports, for supplying a cooling medium into the container, in particular carbon dioxide particles. In special cases liquid nitrogen may be supplied instead of carbon dioxide particles.

By suitably varying respectively adjusting the conveying speed, the container may be filled uniformly even for the case that the articles are not supplied continuously and smoothly to the conveying means. The apparatus may comprise control means for controlling the supply of cooling medium.

Depending on the temperature and / or the amount of the articles to be cooled, the amount of cooling medium may be precisely metered and adjusted.

5 Furthermore, the cooling medium may be added at locations within the container in response to the temperature profile within the container. The amount of added cooling medium may be controllable in response to the amount of articles being conveyed.

10 Preferably at least one temperature sensor, preferably multiple temperature sensors, are provided for the determining the temperature respectively the temperature distribution of the articles. The Temperature respectively the temperature distribution may be determined of the articles on or in the conveying means and/or of the articles in the container. The amount of the cooling medium may be controllable in response to the temperature respectively temperature distribution.

15 The amount of cooling medium to be added may be controllable in response to the temperature of the articles, in particular in temperature of the articles being conveyed, and/or the respectively temperature distribution of the articles with the container.

20 The articles according to the invention are cooled with the process for cooling according to the invention and/or are cooled with the apparatus for cooling according to the invention. The articles may be chilled or at least partially frozen goods. The advantages and technical effects of the invention as described above
25 provide for articles with particular properties with respect to their quality and product homogeneity, which result from the achievable high purity level and the well defined cooling conditions of the system.

Further advantages and details, which may be applied individually or may be combined in any desired and suitable form, will be explained with respect to the following drawings, which shall not restrict but only exemplarily illustrate the invention:

5

Fig. 1 schematically shows the apparatus for cooling according to the invention from a lateral view; and

Fig. 2 shows the container according to Fig. 1 in a view from above.

10

Fig. 1 schematically shows the apparatus 10 for cooling articles 3 according to the invention from a lateral view. Articles supplied by a vibrating trough 20 of a production line (not shown) are supplied onto a conveying means 6 which is provided as conveying belt. The articles 3 are pieces of meat such as de-boned chicken meat, which enter the conveying means 6 in a discontinuous manner and with interruptions. The interruptions may last up to a couple of minutes. The temperature of the articles 3 on the conveying belt may be about 8 ° C.

The articles 3 are conveyed at a conveying speed and are discharged at a conveyor outlet 7 into a container 2 such that the articles 3 accumulate at a first location 8. If the articles 3 are conveyed with a higher conveying speed, the articles 3 follow a trajectory and pile up at a second location 9 in the container 2 which is further away from the conveyor outlet 7 than the first location 8. Thus the lower conveying speed leads to a first pile proximate at the conveyor outlet 7 and the higher conveying speed leads to a second pile distal to the conveyor outlet 7. A first portion 4 of the articles 3 accumulate at the first location 8, and a second portion 5 of the articles 3 accumulate at the second location 9. The portions 4, 5 accumulate in piles within the container 2 wherein the natural angle of the respective piles de-

25

depends on the kind of articles 3. For meat above freezing point this natural angle is approximately 30° to 40°.

Weight sensors 11 measure the weight of the container 2. As the weight sensors
5 11 are located at different places at the container 2, it is possible to estimate the mass distribution of the articles 3 in the container 2 and it is possible to estimate the degree of asymmetry of the filling. If the measured weight difference exceeds a predetermined value, the conveying speed of the conveying means 6 is suitably changed by a control unit 15. Articles 3 are piled up at a location within the con-
10 tainer 2 where too few articles are present. This helps to remove the asymmetry of the mass distribution within the container. The sensors 11 may be fixed to the container 2 but may as well be provided at the machine frame (not shown). For quantifying the mass distribution within the container 2 the sensors 11 may operate mechanically, electronically or optically.

15 A first supply port 17 and a second supply port 18 which are provided as “snow horns” supply cooling medium 13 in form of carbon dioxide pellets into the container 2. The supply ports 17, 18 are fixed to the machine frame (not shown). The amount of cooling medium 13 supplied by the two supply ports 17, 18 is controlled by a control means 19 which may take into account the amount of articles
20 3 being conveyed by the conveying means 6 or the amount of articles 3 in the container 2. The control means 19 controls the supply of cooling medium 13 in response to the temperature either of the articles 3 on the conveying means 6 or of the articles 3 within the container 2 for which purpose temperature sensors 16 are
25 used. The temperature sensors 16 either work mechanically, electronically or optically either by contact or contact-free. The articles 3 are cooled to a temperature of approximately 2°C to 3°C.

The articles 3 are discharged into the container 2 through a receiving opening 14. In order to disperse the articles 3 within the container 2 a simple deflection surface 12 is fixed to the container 2 in order to distribute the articles 3 sideways and to facilitate uniform filling within the container 2. The conveying means 6 in
5 combination with the container 2 and the control unit 15 for controlling the conveying speed forms an apparatus for filling 1 which allows for uniformly filling the container 2 even for the case that the articles 3 enter the apparatus 1 discontinuously or with considerable fluctuations. By means of the apparatus 1 for filling respectively the apparatus 10 for cooling the articles 3 can be treated in a gentle and clean way as the articles 3 come into contact with only a few surfaces such
10 that the risk of contaminations due to difficulties of cleaning the apparatus is reduced.

Fig. 2 shows the container 2 according to Fig. 1 in the top view where the distribution of the articles 3 is illustrated using contour lines 21. As can be clearly seen
15 the first portion 4 corresponding to the lower conveying speed accumulates as a first pile at the first location 8 and the second portion 5 accumulates as a second pile at the second location 9. The second pile at the second location 9 is split up into a double pile due to the use of the deflection surface 12. The deflection surface 12 helps to transfer the articles 3 into the remote corners of the container 2.
20

The invention concerns a process respectively an apparatus for filling a container 2 with articles 3 such as food, in particular meat, and a process respectively an apparatus for cooling articles 3 and is characterised by repeating the following
25 steps: (A) a first portion 4 of the articles 3 is conveyed with a conveying means 6, in particular a conveyor belt, having a conveyor outlet 7 and is discharged into a container 2 at a lower conveying speed such that a first portion 4 accumulates in the container 2 at the first location 8 closer to the conveyor outlet 7; and (B) thereafter, a second portion 5 of the articles 3 is conveyed by the conveying

means 6 and is discharged into a container 2 at a higher conveying speed, such that the second portion 5 accumulates in the container 2 at the second location 9 further away from the conveyor outlet 7; as well as a process respectively an apparatus for cooling articles 3 using said process and said apparatus for filling; as well as the articles processed by said processes respectively said apparatus. The control of the conveying speed allows for reducing the number of necessary surfaces of machinery with which the articles 3 come into contact. The invention effects that the articles 3 may be handled more easily in a clean way without the expense of non-uniform filling of the container. The process and the apparatus is particularly suited for homogenously and efficiently cooling articles using carbon dioxide particles.

Reference numerals

| | | |
|----|----|-----------------------|
| | 1 | apparatus for filling |
| | 2 | container |
| | 3 | articles |
| 5 | 4 | first portion |
| | 5 | second portion |
| | 6 | conveying means |
| | 7 | conveyor outlet |
| | 8 | first location |
| 10 | 9 | second location |
| | 10 | apparatus for cooling |
| | 11 | sensors |
| | 12 | deflection surface |
| | 13 | cooling medium |
| 15 | 14 | receiving opening |
| | 15 | control unit |
| | 16 | temperature sensor |
| | 17 | first supply port |
| | 18 | second supply port |
| 20 | 19 | control means |
| | 20 | vibrating trough |
| | 21 | contour lines |

Patent Claims

1. Process for filling a container (2) with articles (3) such as food, in particular meat, characterized by repeating the following steps:
 - 5 (A) a first portion (4) of the articles (3) is conveyed with a conveying means (6), in particular a conveyor belt, having a conveyor outlet (7) and is discharged into the container (2) at a lower conveying speed, such that the first portion (4) accumulates in the container (2) at a first location (8) closer to the conveyor outlet (7); and
 - 10 (B) thereafter, a second portion (5) of the articles (3) is conveyed on the conveying means (6) and is discharged into the container (2) at a higher conveying speed, such that the second portion (5) accumulates in the container (2) at a second location (9) further away from the conveyor outlet (7).
- 15 2. Process according to claim 1, characterized in that the conveying speed is repeatedly adjusted between at least 3 different speed levels, in particular the conveying speed is repeatedly varied continuously within a range of speed levels.
- 20 3. Process according to claim 1 or 2, characterized in that the conveying speed is controlled in response to the amount of articles (3) being conveyed and/or being accumulated in the container (2).
- 25 4. Process according to one of claims 1 to 3, characterized in that a mass distribution of the articles (3) within the container (2) is quantified using at

least two sensors (11) at the container (2) and the conveying speed is controlled in response to the quantified estimated mass distribution, in particular an asymmetric weight profile of the container is used for controlling the conveying speed.

5

5. Process according to one of claims 1 to 4, characterized in that the articles (3) are dispersed in the container (2), in particular is dispersed sideways, using a deflection surface (12), in particular a deflection surface at or above the container (2).

10

6. Process for cooling articles (3) such as food, in particular meat, characterized by a process for filling as defined in one of claims 1 to 5, wherein repeatedly,

15

(A) a first portion (4) of the articles (3) is conveyed with a conveying means (6), in particular a conveyor belt, having a conveyor outlet (7) and is discharged into a container (2) at a lower conveying speed, such that the first portion (4) accumulates in the container (2) at a first location (8) closer to the conveyor outlet (7), and

20

(B) thereafter a second portion (5) of the articles (3) is conveyed with the conveying means (6) and is discharged into the container (2) at a higher conveying speed, such that the second portion (5) accumulates in the container (2) at a second location (9) further away from the conveyor outlet (7);

25

wherein a cooling medium (13), in particular liquid nitrogen or carbon dioxide particles, is added into the container (2).

7. Process according to claim 6, characterized in that the cooling medium (13) is repeatedly added at the first and the second location (9), in particular together with the articles (3).
- 5 8. Process according to claim 6 or 7, characterized in that the amount of added cooling medium (13) is controlled in response to the amount and/or the temperature of the articles (3) being conveyed.
9. Process according to one of the preceding claims 6 to 8, characterized in
10 that the amount of added cooling medium (13) is controlled in response to the temperature of the articles (3) and/or respectively temperature distribution of the articles (3) within the container (2).
10. Apparatus for filling (1) a container (2) with articles (3) such as food, in
15 particular meat, comprising:
the container (2) with a receiving opening (14) for receiving the articles (3);
a conveying means (6), in particular a conveyor belt, for conveying the articles (3), the conveying means (6) having a conveyor outlet (7)
20 and the conveyor outlet (7) being arranged in relation to the receiving opening (14) such that the articles (3) discharged from the conveyor outlet (7) enter into the container (2);
wherein for uniformly filling the container (2), the conveying means (6) is operable at at least two different conveying speeds such that,

at a lower conveying speed, a first portion (4) of the articles (3) accumulates in the container (2) at a first location (8) closer to the conveyor outlet (7) and,

5 at a higher conveying speed, a second portion (5) of the articles (3) accumulates in the container (2) at a second location (9) further away from the conveyor outlet (7).

11. Apparatus (1) according to claim 9, characterized in that the conveying means (6) is operable at more than 2 conveying speeds, in particular the conveying speed is repeatedly variable continuously within a range of speed levels.
- 10
12. Apparatus (1) according to claim 9 or 10, characterized by a control unit (15) for controlling uniform filling of the container (2).
- 15
13. Apparatus (1) according to claim 11, characterized in that at least two sensors (11) are provided in, at or below the container (2), in particular separately from the container (2), in order to quantify the mass distribution of the articles (3) within the container (2) and/or in order to gather information on an asymmetric weight profile within the container (2), wherein the conveying speed is controllable in response to the estimated mass distribution.
- 20
14. Apparatus (1) according to one of claims 9 to 12, characterized by a deflection surface (12) at the receiving opening (14) of the container (2), in particular a deflection surface separate from the container (2), for dispersing the articles (3), in particular sideways, in the container (2).
- 25

15. Apparatus for cooling (10) articles (3) such as food, in particular meat, characterized in that an apparatus for filling (1) as defined in one of claims 10 to 13 is provided, further comprising
- 5 a container (2) with a receiving opening (14) for receiving the articles (3);
- a conveying means (6), in particular a conveyor belt, for conveying the articles (3), the conveying means (6) having a conveyor outlet (7) and the conveyor outlet (7) being arranged in relation to the receiving opening (14) such that the articles (3) having been discharged from the conveyor outlet (7) accumulate in the container (2);
- 10 wherein for uniformly filling the container (2), the conveying means (6) is operable at at least two different conveying speeds such that,
- at a lower conveying speed, a first portion (4) of the articles (3) accumulates in the container (2) at a first location (8) closer to the conveyor outlet (7) and,
- 15 at a higher conveying speed, a second portion (5) of the articles (3) accumulates in the container (2) at a second location (9) further away from the conveyor outlet (7);
- 20 further comprising at least one supply port (17, 18), preferably at least two supply ports (17, 18), for supplying a cooling medium (13) into the container (2), in particular liquid nitrogen or carbon dioxide particles.
- 25 16. Apparatus (10) according to claim 14, characterized in that a control means (19) is provided for controlling the supply of cooling medium (13).

17. Apparatus (10) according to claim 15, characterized in that the at least one supply port (17, 18) is controllable such that the cooling medium (13) is repeatedly added to the first location (8) and the second location (9), in particular together with the articles (3).
18. Apparatus (10) according to claim 15 or 16, characterized in that the amount of added cooling medium (13) is controllable in response to the amount of articles (3) being conveyed.
19. Apparatus (1) according to one of claims 14 to 17, characterized in that at least one temperature sensor (16), preferably multiple temperature sensors, is provided for determining the temperature respectively the temperature distribution of the articles (3) conveyed by the conveying means (6) and/or in the container (2).
20. Apparatus (1) according to one of the preceding claims 16 to 18, characterized in that the amount of added cooling medium (13) is controllable in response to the temperature of the articles (3), in particular the temperature of the articles (3) being conveyed, and/or the temperature respectively temperature distribution of the articles (3) within the container (2).
21. Articles (3), in particular chilled or frozen goods, in particular food such as meat, cooled with a process according to one of claims 6 to 9 and/or cooled with a apparatus for cooling (10) according to one of claims 14 to 19.

Fig. 1

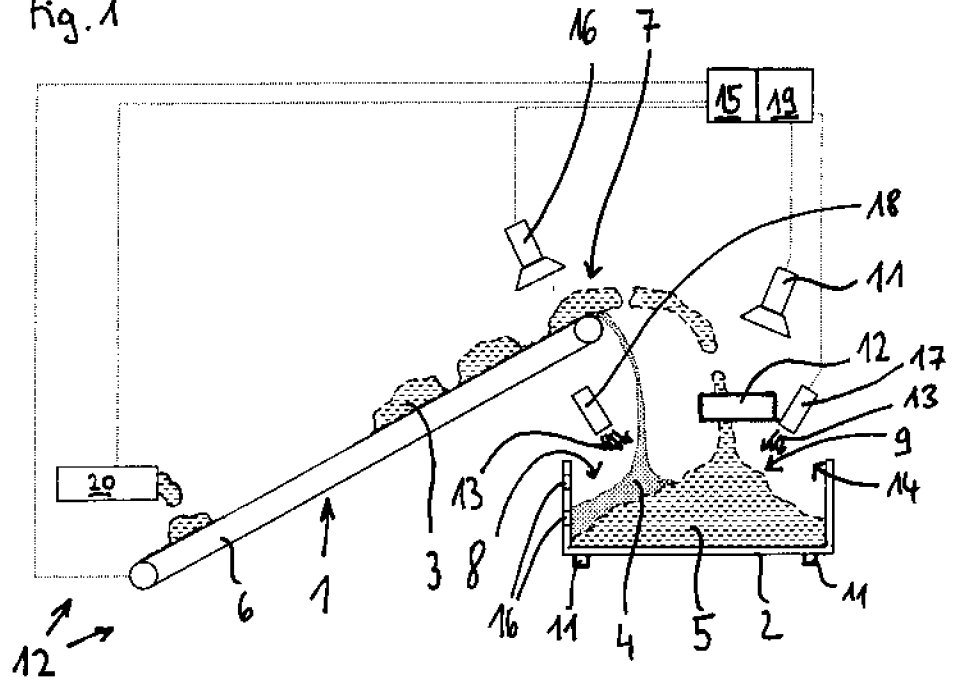
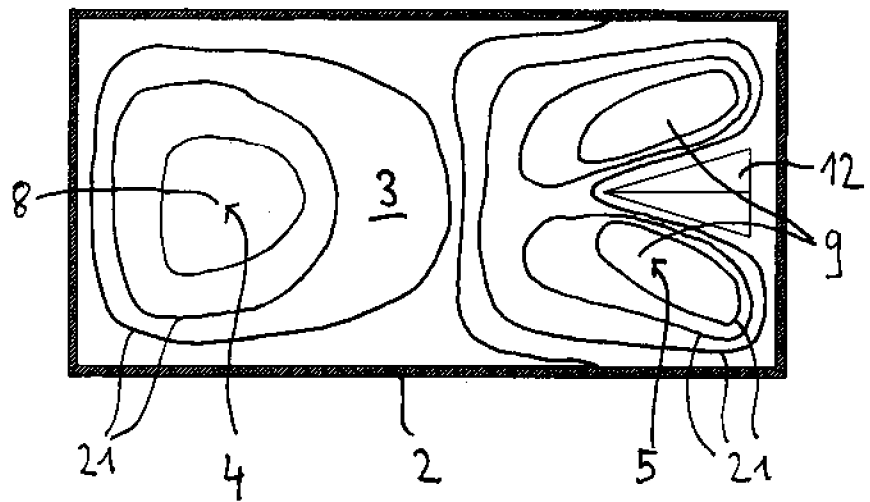

Fig. 2



INTERNATIONAL SEARCH REPORT

International application No
PCT/EP2006/068213

A. CLASSIFICATION OF SUBJECT MATTER
INV. B65B25/06 B65G69/04 B65B35/44

According to International Patent Classification (IPC) or to both national classification and IPC

B. FIELDS SEARCHED

Minimum documentation searched (classification system followed by classification symbols)
B65B B65G

Documentation searched other than minimum documentation to the extent that such documents are included in the fields searched

Electronic data base consulted during the international search (name of data base and, where practical, search terms used)

EPO-Internal, WPI Data, PAJ

C. DOCUMENTS CONSIDERED TO BE RELEVANT

| Category* | Citation of document, with indication, where appropriate, of the relevant passages | Relevant to claim No. |
|-----------|---|-----------------------|
| X | US 4 820 108 A (KNEER ET AL) 11 April 1989 (1989-04-11) | 1, 10 |
| Y | the whole document | 6, 14 |
| Y | EP 0 632 966 A (THE BOC GROUP, INC) 11 January 1995 (1995-01-11) cited in the application the whole document | 6, 14 |
| A | US 5 588 285 A (ODENTHAL ET AL) 31 December 1996 (1996-12-31) abstract; figure 1 | 1-20 |
| A | WO 93/14358 A (L'AIR LIQUIDE, SOCIETE ANONYME POUR L'ETUDE ET L'E) 22 July 1993 (1993-07-22) cited in the application the whole document | |
| | -/-- | |

Further documents are listed in the continuation of Box C.

See patent family annex.

* Special categories of cited documents :

- *A* document defining the general state of the art which is not considered to be of particular relevance
- *E* earlier document but published on or after the international filing date
- *L* document which may throw doubts on priority claim(s) or which is cited to establish the publication date of another citation or other special reason (as specified)
- *O* document referring to an oral disclosure, use, exhibition or other means
- *P* document published prior to the international filing date but later than the priority date claimed

- *T* later document published after the international filing date or priority date and not in conflict with the application but cited to understand the principle or theory underlying the invention
- *X* document of particular relevance; the claimed invention cannot be considered novel or cannot be considered to involve an inventive step when the document is taken alone
- *Y* document of particular relevance; the claimed invention cannot be considered to involve an inventive step when the document is combined with one or more other such documents, such combination being obvious to a person skilled in the art.
- * & * document member of the same patent family

Date of the actual completion of the international search

9 February 2007

Date of mailing of the international search report

22/02/2007

Name and mailing address of the ISA/
European Patent Office, P.B. 5818 Patentlaan 2
NL - 2280 HV Rijswijk
Tel. (+31-70) 340-2040, Tx. 31 651 epo nl,
Fax: (+31-70) 340-3016

Authorized officer

Ungureanu, Mirela

INTERNATIONAL SEARCH REPORT

International application No

PCT/EP2006/068213

C(Continuation). DOCUMENTS CONSIDERED TO BE RELEVANT

| Category* | Citation of document, with indication, where appropriate, of the relevant passages | Relevant to claim No. |
|-----------|--|-----------------------|
| A | DE 89 09 823 U1 (WILHELM STOLL MASCHINENFABRIK GMBH, 3325 LENGEDE, DE) 12 October 1989 (1989-10-12) abstract; figure 1 ----- | |
| A | US 3 996 723 A (GREENWELL ET AL) 14 December 1976 (1976-12-14) figure 1 ----- | |

INTERNATIONAL SEARCH REPORT

Information on patent family members

International application No

PCT/EP2006/068213

| Patent document cited in search report | | Publication date | | Patent family member(s) | Publication date |
|--|----|------------------|------|-------------------------|------------------|
| US 4820108 | A | 11-04-1989 | DE | 3611785 A1 | 15-10-1987 |
| EP 0632966 | A | 11-01-1995 | CA | 2123384 A1 | 10-01-1995 |
| | | | DE | 69406504 D1 | 04-12-1997 |
| | | | DE | 69406504 T2 | 26-02-1998 |
| | | | ID | 1030 B | 22-10-1996 |
| | | | US | 5363658 A | 15-11-1994 |
| | | | ZA | 9404209 A | 13-06-1995 |
| US 5588285 | A | 31-12-1996 | AT | 174854 T | 15-01-1999 |
| | | | DE | 9410970 U1 | 27-10-1994 |
| | | | EP | 0696538 A1 | 14-02-1996 |
| WO 9314358 | A | 22-07-1993 | AU | 3503193 A | 03-08-1993 |
| | | | BR | 9303962 A | 02-08-1994 |
| | | | CA | 2106576 A1 | 22-07-1993 |
| | | | DE | 69322695 D1 | 04-02-1999 |
| | | | DE | 69322695 T2 | 17-06-1999 |
| | | | DK | 576665 T3 | 23-08-1999 |
| | | | EP | 0576665 A1 | 05-01-1994 |
| | | | ES | 2125328 T3 | 01-03-1999 |
| | | | FR | 2686403 A1 | 23-07-1993 |
| | | | JP | 2854978 B2 | 10-02-1999 |
| | | | JP | 6505792 T | 30-06-1994 |
| | | | NZ | 249150 A | 24-02-1995 |
| | | | US | 5351495 A | 04-10-1994 |
| | | | ZA | 9300398 A | 15-11-1993 |
| DE 8909823 | U1 | 12-10-1989 | NONE | | |
| US 3996723 | A | 14-12-1976 | NONE | | |