

[54] **HOLSTER PRODUCTION BLANK**

[76] Inventors: Michael T. Merritt; James M. Kelly, both of 692 S. Main St., Moab, Utah 84532

[**] Term: 14 Years

[21] Appl. No.: 702,796

[22] Filed: Feb. 19, 1985

[52] U.S. Cl. D3/101

[58] Field of Search D3/101; 224/94

[56] **References Cited**

U.S. PATENT DOCUMENTS

3,902,639 9/1975 Rogers D3/101

OTHER PUBLICATIONS

Blue Steel & Gunleather by John Bianchi, c. 1978, p. 202, FIG. 8, holster illustration.

Primary Examiner—A. Hugo Word

Attorney, Agent, or Firm—Norvell E. Von Behren

[57] **CLAIM**

The ornamental design for a holster production blank, substantially as shown and described.

DESCRIPTION

FIG. 1 is a front view of the holster production blank showing our new design.

FIG. 2 is a rear view of the holster production blank showing our new design.

FIG. 3 is a side view, taken along line 3—3 of FIG. 1. FIG. 4 is another side view, taken along line 4—4 of FIG. 1.

FIG. 5 is a cross-sectional view, taken along line 5—5 of FIG. 1.

FIG. 6 is a cross-sectional view, taken along line 6—6 of FIG. 1.

FIG. 7 is a top view, taken along line 7—7 of FIG. 1.

FIG. 8 is a bottom view, taken along line 8—8 of FIG. 1.

FIG. 9 is a front view of a modification of the applicant's design.

FIG. 10 is a rear view of the modification shown in FIG. 9.

FIG. 11 is a side view, taken along line 11—11 of the modification shown in FIG. 9.

FIG. 12 is another side view, taken along line 12—12 of the modification shown in FIG. 9.

FIG. 13 is a cross-sectional view, taken along line 13—13 of the modification shown in FIG. 9.

FIG. 14 is a cross-sectional view, taken along line 14—14 of the modification shown in FIG. 9.

FIG. 15 is a top view, taken along line 15—15 of the modification shown in FIG. 9.

FIG. 16 is a bottom view, taken along line 16—16 of the modification shown in FIG. 9.

The dashed lines shown in the drawing figures represent sewing lines for the applicant's design.

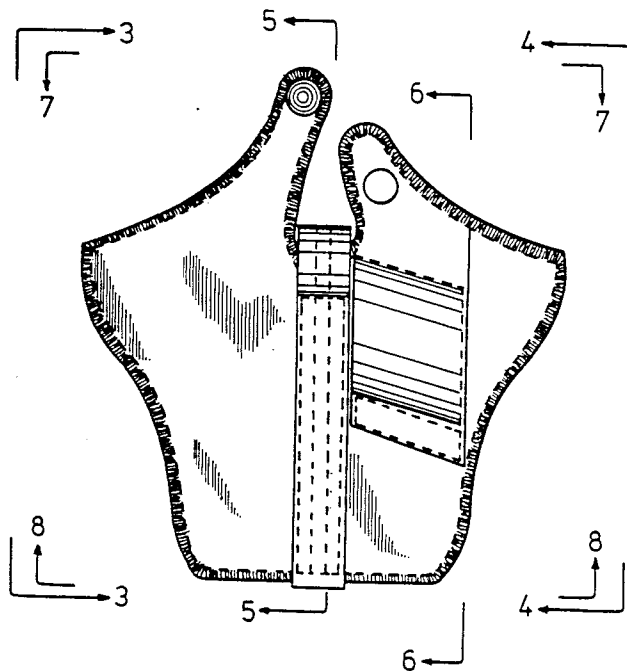

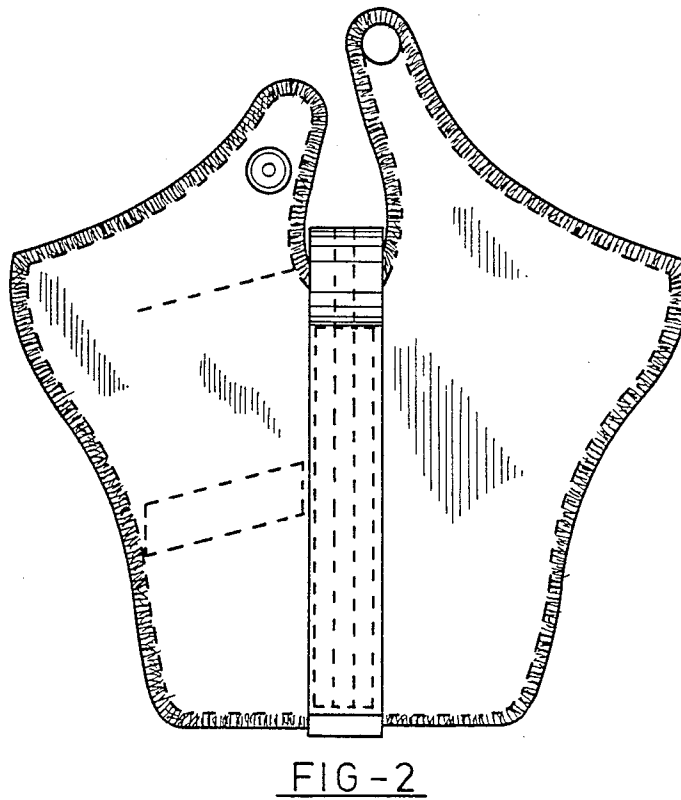
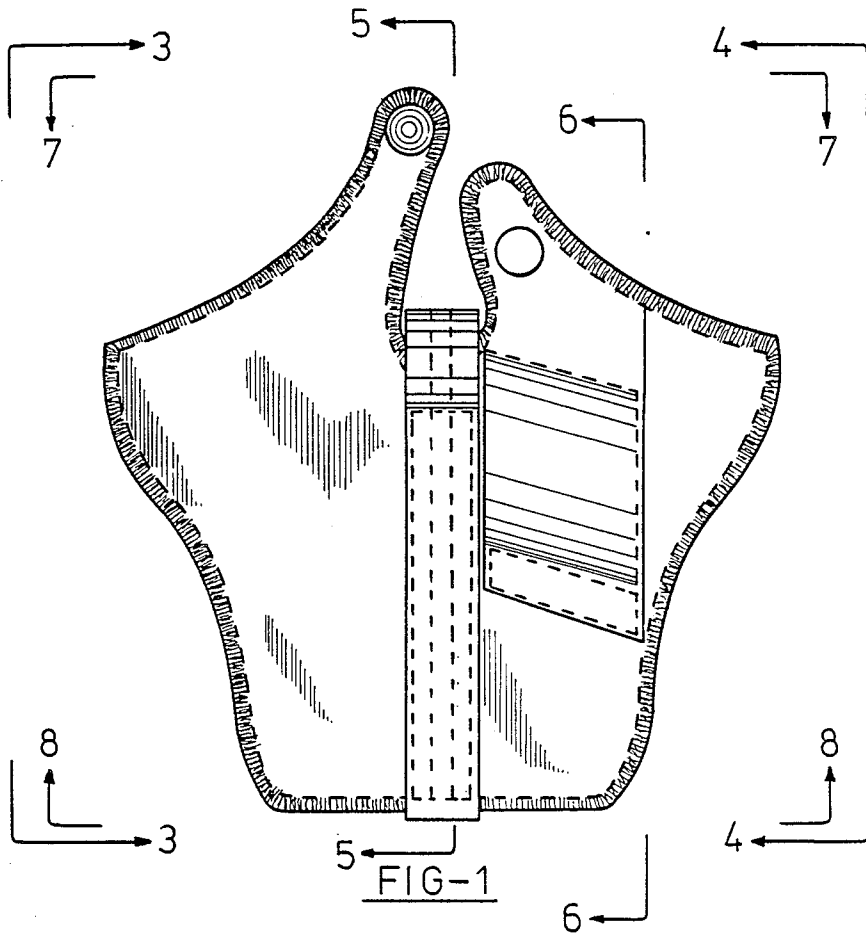



FIG-3



FIG-4



FIG-5



FIG-6

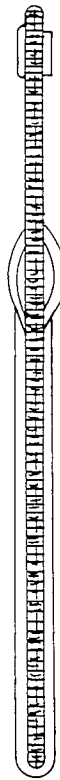

FIG-11

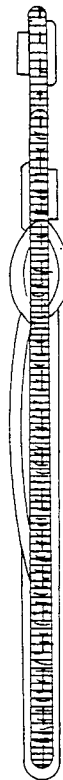

FIG-12



FIG-13



FIG-14

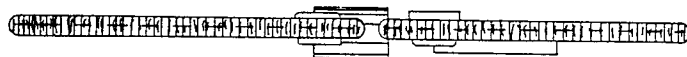

FIG-7

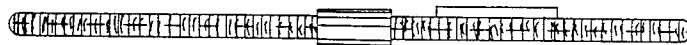

FIG-8

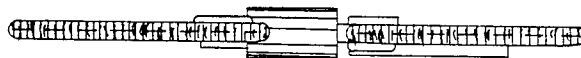

FIG-15

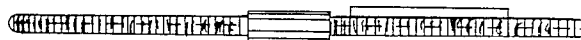

FIG-16

