



(51) International Patent Classification:

G02B 1/04 (2006.01) G02C 7/04 (2006.01)
G02C 7/02 (2006.01)

(21) International Application Number:

PCT/US2019/047058

(22) International Filing Date:

19 August 2019 (19.08.2019)

(25) Filing Language:

English

(26) Publication Language:

English

(30) Priority Data:

62/765,088 17 August 2018 (17.08.2018) US

(71) Applicant: **STAAR SURGICAL COMPANY** [US/US];
1911 Walker Avenue, Monrovia, CA 91016 (US).

(72) Inventors: **OSSIPOV, Alexei, V.**; 1911 Walker Avenue,
Monrovia, CA 91016 (US). **HOLLIDAY, Keith**; 1911
Walker Avenue, Monrovia, CA 91016 (US).

(74) Agent: **ZLOGAR, Thomas, M.** et al.; Shay Glenn LLP,
2755 Campus Drive, Suite 210, San Mateo, CA 94403 (US).

(81) Designated States (unless otherwise indicated, for every

kind of national protection available): AE, AG, AL, AM, AO, AT, AU, AZ, BA, BB, BG, BH, BN, BR, BW, BY, BZ, CA, CH, CL, CN, CO, CR, CU, CZ, DE, DJ, DK, DM, DO, DZ, EC, EE, EG, ES, FI, GB, GD, GE, GH, GM, GT, HN, HR, HU, ID, IL, IN, IR, IS, JO, JP, KE, KG, KH, KN, KP, KR, KW, KZ, LA, LC, LK, LR, LS, LU, LY, MA, MD, ME, MG, MK, MN, MW, MX, MY, MZ, NA, NG, NI, NO, NZ, OM, PA, PE, PG, PH, PL, PT, QA, RO, RS, RU, RW, SA, SC, SD, SE, SG, SK, SL, SM, ST, SV, SY, TH, TJ, TM, TN, TR, TT, TZ, UA, UG, US, UZ, VC, VN, ZA, ZM, ZW.

(84) Designated States (unless otherwise indicated, for every

kind of regional protection available): ARIPO (BW, GH, GM, KE, LR, LS, MW, MZ, NA, RW, SD, SL, ST, SZ, TZ, UG, ZM, ZW), Eurasian (AM, AZ, BY, KG, KZ, RU, TJ, TM), European (AL, AT, BE, BG, CH, CY, CZ, DE, DK, EE, ES, FI, FR, GB, GR, HR, HU, IE, IS, IT, LT, LU, LV, MC, MK, MT, NL, NO, PL, PT, RO, RS, SE, SI, SK, SM, TR), OAPI (BF, BJ, CF, CG, CI, CM, GA, GN, GQ, GW, KM, ML, MR, NE, SN, TD, TG).

(54) Title: POLYMERIC COMPOSITION EXHIBITING NANOGRAIDENT OF REFRACTIVE INDEX

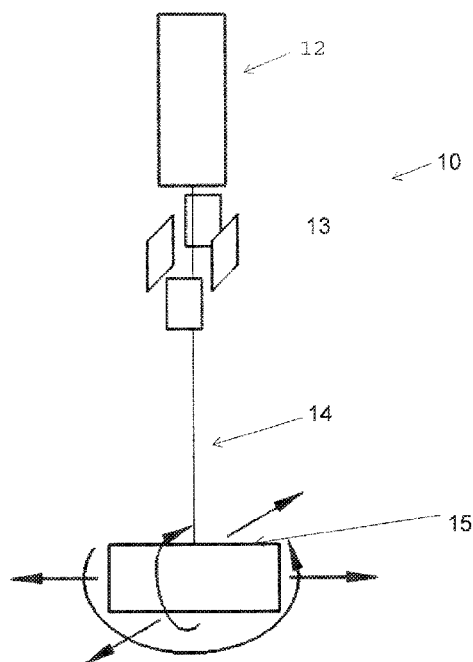

Fig. 1

(57) Abstract: Ionized radiation-absorbed, dose sensitive, highly flexible polymeric compositions are provided that exhibits multidirectional changes in refractive index. Also provided are methods of producing a precision multi-directional nanogradient of refractive index in a polymeric composition.



Published:

- *with international search report (Art. 21(3))*
- *before the expiration of the time limit for amending the claims and to be republished in the event of receipt of amendments (Rule 48.2(h))*

**POLYMERIC COMPOSITION EXHIBITING
NANOGRADIENT OF REFRACTIVE INDEX**

CROSS REFERENCE TO RELATED APPLICATIONS

- 5 **[0001]** This application claims the benefit of U.S. Provisional Application No. 62/765,088, filed August 17, 2018, which is incorporated by reference herein for all purposes.

FIELD OF THE INVENTION

- 10 **[0002]** An ionized radiation-absorbed, dose sensitive, highly flexible polymeric composition is provided that exhibits multidirectional changes in refractive index. Also provided is a method of producing a precision multi-directional gradient of refractive index in a polymeric composition.

BACKGROUND OF THE DISCLOSURE

- 15 **[0003]** A lens that has a refractive index that varies in a controlled way throughout its body is referred to as a gradient refractive index (GRIN) lens. The refractive index typically changes as a gradient, in that it varies gradually throughout the body of the lens. The naturally occurring human crystalline lens is an example of a lens having a gradient of refractive index.
- 20 **[0004]** Production of a single piece foldable multifocal gradient intraocular lens (IOL) has been reported wherein the IOL was manufactured with step-by-step polymerization technology in transfer molds of photohardening material (ultraviolet light) with various refraction indices (oligourethan-methacrylate). See Malyugin et al., Middle East Afr. J. Ophthalmol. 2014 Jan-Mar; 21(1): 32–39. This technology can produce multifocal artificial lenses with gradient optics.
- 25 However, the manufacturing process combines stages of material polymerization with lens manufacturing concurrently.

Summary of the Disclosure

- 30 **[0005]** Methodology for forming GRIN IOLs is desirable, in that optical parameters, such as image quality, focal length, and depth of focus, can be defined for the manufactured lens by controlling the variation in refractive index. This methodology enables ophthalmic lenses (e.g., IOLs) to be manufactured to specification for a particular patient's vision correction requirements. Methodology that enables refractive index modification of a previously

manufactured ophthalmic lens would be desirable, as would methodology for preparation of GRIN lenses for applications other than intraocular use.

5 [0006] One aspect of the disclosure is a lens, optionally an ophthalmic lens, including an optic body made from a copolymer having a three-dimensional polymeric matrix, wherein the three dimensional polymeric matrix of the copolymer has a non-uniform cross-link density.

[0007] The three dimensional polymeric matrix may include a first region with fewer cross links than a second region.

10 [0008] The first region and the second region may be within a gradient of cross-link density. The three dimensional polymeric matrix may further include a third region that is not within the gradient, the third region including a layer having a uniform cross-link density. The first region may be closer to a periphery of the optic body than the second region.

[0009] The first region may be a first layer with a first cross-link density, and the second region may be a second layer with a second cross-link density. The first region may be a surface layer of the optic body, the first region having fewer cross-links than the second region.

15 [0010] The first region may be closer to a periphery of the optic body.

[0011] The entire optic body may have a gradient cross-link density.

[0012] The three-dimensional polymeric matrix may have a refractive index distribution substantially the same as a refractive index distribution of a natural crystalline lens.

20 [0013] A shape of the optic body may be substantially the same as a shape of a natural crystalline lens.

[0014] The entire optic body may not have a gradient cross-link density.

[0015] The optic body may be a toric lens.

25 [0016] The copolymer may include at least one non-ionic acrylic monomer and at least one ionic monomer. The copolymer may further comprise a collagen material. The ionic monomer may be an organic acid. A weight ratio of the non-ionic acrylic monomer to the ionic monomer may be 10:1 to 10,000:1, such as 50:1 to 200:1, such as 75:1 to 175:1, such as 75:1, 100:1, 125:1, 150:1, or 175:1. The non-ionic acrylic monomer may be hydroxyethylmethacrylate.

[0017] The non-uniform crosslink density of the matrix may be adapted to create an anti-reflection surface layer in the optic body when the optic body is exposed to aqueous in an eye.

30 An anti-reflection layer may comprise a region of the matrix that is 50 nm to 400 nm thick. The anti-reflection layer may comprise a region of the matrix that is .1 micron to 10 microns thick. The anti-reflection layer may comprise a region of the matrix that is 1 micron to 100 microns thick. The anti-reflection surface layer may be at least partially disposed around a central aperture formed in the optic body.

35 [0018] The optic body may be an optic body of an IOL.

[0019] The three-dimensional matrix may be dimensionally stable through steam sterilization as part of a "wet pack" and is hydrolytically stable during long term use.

[0020] The non-uniform cross-link density may adapt the optic body, when placed in an eye and exposed to aqueous, to focus light from a wide range of distances without moving or changing shape, optionally with a vergence of 0 to 3 D, optionally 0 to 2.5 D, optionally 0 to 2 D, optionally 0 to 1.5 D, optionally 0 to 1.0 D.

[0021] The non-uniform cross-link density may adapt the optic body, when placed in an eye and exposed to aqueous, to correct for astigmatism.

[0022] The three dimensional polymeric matrix may have a lower cross-link density near a surface of the optic body than in a region further inward relative to the surface.

[0023] The lens may further comprise a non-optic body portion (e.g., one or more haptics), and wherein the non-optic body portion includes a non-optic three-dimensional polymeric matrix, wherein the non-optic three dimensional polymeric matrix has a non-uniform cross-link density.

[0024] The lens may further comprise a hydrating solution to which the optic body has been exposed, wherein the non-uniform cross-link density causes the three-dimensional polymeric matrix to swell in a non-uniform manner when hydrated in the solution, thereby creating a non-uniform refractive index within the optic body.

[0025] The hydrating solution may be a balanced salt solution.

[0026] The hydrating solution may include constituent parts such that when the lens is exposed to aqueous humor in an eye, the amount of swelling in the three-dimensional polymeric matrix will not substantially change. The hydrating solution may be a balanced salt solution.

[0027] The hydrating solution may include constituent parts such that when the lens is exposed to aqueous humor in an eye, the amount of swelling in the three-dimensional polymeric matrix increases. The hydrating solution may be a sodium chloride solution.

[0028] The hydrating solution may include constituent parts such that when the lens is exposed to aqueous humor in an eye, the amount of swelling in the three-dimensional polymeric matrix decreases.

[0029] The hydrating solution may include at least one of magnesium ions or calcium ions.

[0030] The non-uniform refractive index may include first and second discrete layers having first and second refractive indices, respectively. The non-uniform cross-link density may further include a gradient cross-link density.

[0031] One aspect of the disclosure is a method of placing any of the lenses herein in a hydrating solution, wherein placing the lens in the hydrating solution causes a non-uniform

swelling of the matrix, thereby creating a non-uniform refractive index in the optic body. The method may include placing the lens in a balanced salt solution.

[0032] One aspect of the disclosure is a method of implanting any of the lenses herein, wherein the method of implanting causes a change in the swelling in the matrix.

5 Implanting may cause the matrix to swell more in at least a portion of the matrix. Implanting may cause a decrease in swelling in at least a portion of the matrix. Implanting the lens may cause the lens to increase in overall volume to an implanted configuration.

[0033] One aspect of the disclosure is a method of implanting any of the lenses herein, wherein the method of implanting does not causes a substantial change in the swelling in
10 the matrix.

[0034] One aspect of the disclosure is a method of implanting any of the lenses herein, wherein implanting the lens comprises inserting the lens through a delivery device in a state in which the lens has a smaller volume than a lens volume in a fully hydrated, implanted state.

15 **[0035]** One aspect of the disclosure is a method for inducing a refractive index gradient in a three-dimensional polymeric matrix, the method including providing a formed body (e.g., already cured) having a three-dimensional polymeric matrix comprising a copolymer system prepared from at least one non-ionic acrylic monomer and at least one ionic monomer; and irradiating the three-dimensional polymeric matrix with ionizing energy in a pattern
20 configured to thereby create a non-uniform cross-link density within the matrix.

[0036] The method can be used in combination with any of the lenses herein.

[0037] The ionizing energy may be electron beams. The ionizing energy may be x-rays.

[0038] The method may further include maintaining the body in a stationary position,
25 and wherein irradiating comprises moving an ionizing energy source in at least one direction. The method may include maintaining an ionizing energy source in a stationary position, and moving the body in at least one direction during the irradiating step. The method may include moving both the body and the energy source, simultaneously or serially, or any combination thereof.

30 **[0039]** The irradiating step may create a gradient of cross-link density in at least a portion of the matrix.

[0040] The irradiating step may create a gradient of cross-link density in substantially the entire matrix.

- [0041] The irradiating step may create a first layer with a first cross-link density less than a cross-link density of a second region the matrix. The first layer may be a surface layer of the body.
- [0042] The copolymer system may further comprise a collagen material.
- 5 [0043] The ionic monomer may be an organic acid.
- [0044] The at least one non-ionic acrylic monomer may be hydroxyethylmethacrylate, and wherein the at least one ionic monomer may be an acrylic monomer.
- [0045] The body may be an optic body of an intraocular lens.
- 10 [0046] The irradiated three-dimensional polymeric matrix may be dimensionally stable through steam sterilization as part of a "wet pack" and may be hydrolytically stable during long term use.
- [0047] The irradiating step may create a surface anti-reflective layer, optionally from 50 nm to 400 nm thick, optionally from .1 microns to 10 microns thick, or optionally from 15 micron to 100 microns thick.
- [0048] The irradiating step may create a non-uniform cross-link density such that, when the body is hydrated in aqueous in an eye, the body is adapted to focus light from a wide range of distances without moving or changing shape, optionally with a vergence of 0 to 3 D, optionally 0 to 2.5D, optionally 0 to 2D, optionally 0 to 1.5 D.
- 20 [0049] The irradiating step can be initiated after one or more peripheral support (e.g., haptics) have already been formed integrally with the formed body.
- [0050] The ionizing energy may be X-rays.

25

BRIEF DESCRIPTION OF THE DRAWINGS

- [0051] Figure 1 is an exemplary system for applying ionizing energy to a polymeric body.
- [0052] Figure 2 illustrates an exemplary technique when applying ionizing energy to a lens body.
- [0053] Figure 3A illustrates a formed (e.g., cured) polymeric material with crosslinks.
- 30 [0054] Figure 3B illustrates the formed polymeric material from figure 3A after being hydrated in solution, which causes swelling.
- [0055] Figure 4A illustrates a formed polymeric material after exposure to ionizing energy.
- [0056] Figure 4B illustrates the polymeric material from figure 4A after being hydrated in solution, which causes swelling. More swelling has occurred in figure 4B than in figure 3B.
- 35 [0057] Figure 5 illustrates in additional detail a manner in which swelling herein may occur.

[0058] Figure 6 illustrates an exemplary lens with a thin anti-reflection layer formed therein, including a main lens body portion.

[0059] Figure 7 illustrates how the thickness of a modified surface layer is influenced by the electron energy.

5 [0060] Figure 8 illustrates the relatively higher energy range for beta radiation, compared to figure 7.

[0061] Figure 9 shows the percentage change in refractive index, wherein 100% refers to a surface RI unchanged from the bulk and 0% refers to the surface RI being reduced to the RI of the solution in which it is held.

10 [0062] Figure 10 is an exemplary lens that can have a refractive index distribution substantially the same as a native crystalline lens.

[0063] Figure 11 illustrates an exemplary optic body with a varying RI in the optic body that can be created using the methods herein.

15 [0064] Figure 12 shows a portion of a polymer chain with the acrylic acid side group (left) and methacrylate side group (right).

[0065] Figure 13A illustrates an exemplary lens that may be irradiated using the methods herein, the lens including one or more apertures in the optic.

20 [0066] Figure 13B illustrates a central aperture of an optic body and a region around the aperture that may be irradiated using methods herein to create an anti-reflection layer at the location of the aperture.

Detailed Description of the Disclosure

25 [0067] One aspect of the disclosure includes lenses (e.g., ophthalmic lenses) that have been manufactured with a refractive index ("RI") that varies in a controlled way throughout their lens bodies. In some instances the RI varies in only a portion of the lens body. In some instances the varying RI may be a gradient RI, while in some examples it may refer generally to one or more layers of the body each having a different RI. The lenses herein may include one or more body regions having a gradient RI, as well as one or more body regions having a uniform RI, and any
30 combination thereof.

[0068] One aspect of this disclosure is related to methods of creating the varying RI in the lens.

[0069] In general, the methods of creating the variable RI in the lens body (which may be referred to herein as an optic body) occur after the body of the material has been formed, i.e., after curing one or more monomers to form a cured body of polymeric material. This is in

contrast to alternative approaches that may create a varying RI during the process of forming the body.

[0070] The methods herein that create the varying RI may take place after one or more optic surfaces have already been formed in an optic body (e.g., via lathing to create the one or more optic surfaces). Alternatively, the methods that create the varying RI may occur prior to forming one or more optic surfaces of an optic body. For example, the methods may occur prior to an anterior and/or a posterior surface of an optic body being formed (e.g., lathing). In these alternative examples, the methods may be performed on, for example, a cured body of polymeric material (e.g., a cylindrical button), after which one or more optical surfaces may then be formed thereon.

[0071] An exemplary advantage of the methods described herein is it can be used on a wide variety of optic bodies that have been formed using known curing techniques. This allows for existing techniques to be used to form a body of material (e.g., curing), after which the methods herein can be utilized to modify the RI in one or more regions of the lens in a very controlled manner to treat a wide variety of optical disorders (e.g., astigmatism) or to modify the lens in other ways to create a desired optical effect (e.g., creating an anti-reflective surface layer in an outermost region of the lens).

[0072] The term "refractive index" ("RI") herein encompasses a measurement of the degree of refraction in translucent/transparent substances, especially the ocular media. The RI is measured as the relative velocity of light in another medium (such as a polymeric material) as compared to the velocity of light in vacuum. For example, the RI (n) of water is 1.33.

[0073] Any of the lenses herein may have one or more regions that have a gradient RI. Any of the lenses herein may have one or more regions that interface where there is an abrupt change in RI between the regions. Any of the lenses herein may have one or more regions that have a constant RI. Any of the lenses herein may include any combination of the exemplary regions set forth in this paragraph. Any of the methods of use herein may be utilized to create any of the lenses set forth in this paragraph.

[0074] The natural human crystalline lens is a gradient refractive index lens (GRIN) and the RI typically changes as a gradient, in that it varies gradually throughout the body of the lens. As an example, the methods herein can facilitate the manufacture of lenses that have similar performance to the crystalline lens of the eye by defining optical parameters, such as image quality, focal length, and depth of focus, by controlling the variation in refractive index, and the manufactured lenses are GRIN lenses. However, in some lenses, it may be advantageous to provide an artificial lens that has one or more abrupt changes in RI instead, or in addition to, a gradient. Portions of the lens may also have a constant RI.

[0075] The disclosure herein includes methods of creating desired RI profiles within an already-formed lens. The techniques herein apply ionizing energy in a particular pattern or manner to a formed polymeric material, and in some instances the ionizing energy may be electron beams. The electron beams (or other ionizing energy) cause bonds to break in the formed polymeric material. Subsequently, when the polymeric material is hydrated in solution (e.g., balanced salt solution (“BSS”) or other solvents (e.g., water)), the polymeric material swells. The swelling of the polymeric material causes a reduction in the RI. In this manner, the applied energy can be used to vary the RI in the lens in a controlled and predictable manner to create a desired RI profile for the lens.

[0076] To form the polymeric body, cross-linking first takes place. This may be referred to herein as “curing,” and this can be performed using known techniques. In some embodiments, first and second components are cross-linked to produce a three-dimensional structural random copolymer. Chemical crosslinking can be conducted using a combination of initiators and/or crosslinkers and/or catalysts. Alternatively, crosslinking can be initiated by using Compton electrons indirectly generated in a nuclear irradiator. For example, a cesium 137 or cobalt 60 source can be employed that provides gamma radiation that penetrates into the material of the lens, ionizes the material and generates Compton electrons (i.e., the electrons that are detached during ionization). Both the chemical crosslinking method and the nuclear irradiator crosslinking method provide an environment that results in a uniform crosslinking rate within the reaction region, and thus a homogeneous polymer can be produced.

[0077] The copolymer can take the form of a tangled coil in BSS instead of being linear. The random three-dimensional crosslinked coils only form when the intermolecular forces between the copolymer and the solvent molecules are equal to the forces between the solvent molecules, and also equal to the forces between copolymer chain segments. The random three-dimensional crosslinked coils form if, during the polymerization/crosslinking process, a destructive process occurs during the end gelation equilibrating point so that construction and destruction rates become equal. Again, this can be possible with either chemical crosslinking or a radiation process. In the chemical crosslinking process, a combination of initiators and/or crosslinkers and/or catalysts that are promoting crosslinking are matched by the action of an inhibitor. In a radiation process, crosslinking and bond breakage begin to take place at the same rate when the crosslinking density reaches a critical level.

[0078] After the polymeric body is formed, ionizing energy is applied to the polymeric body, resulting in the breaking of cross-linked bonds. Figure 1 conceptually illustrates system 10, which includes ionizing energy source 12, ionizing energy 14, and already-formed (cured) polymeric body 15. Polymeric body 15 may or may not yet have optic surfaces

formed thereon. The polymeric body 15 may be mounted in a stable manner and then irradiated using ionizing energy 14. If electron beams are the ionizing energy, electron beam technology as is employed in electron beam lithography for semiconductor manufacture can readily be adapted for use in the methods of the embodiments herein. Electron beam technology enables one to draw custom patterns (direct-write) with sub-10 nm resolution. See, e.g., Altissimo, M., E-beam lithography for micro-/nanofabrication *Biomicrofluidics* 4, 026503 (2010). Deflection plates 13 are also shown, which are used to create a potential that deflects the beam onto the body 15.

[0079] Different system configurations are contemplated. For example, a static lens can be provided, and an electron beam can be provided that can move relative to the static lens to produce a pattern of irradiation. Alternatively, a stationary source may be used and the polymeric body may be adapted to be moved, such as is shown in the optional degrees of freedom illustrated as arrows in figure 1. Alternatively, both the source and the lens may be moved.

[0080] The pattern of irradiation is defined by electron energy and the direction and position at which electrons hit the lens, and the time for which any position in space is being irradiated. Conversely, a lens adapted to be moved, (e.g., in 6 degrees of freedom as illustrated in figure 1) can be provided that is placed in the path of a static electron beam, and moved accordingly with respect to the beam to produce a pattern of irradiation. A configuration in which both the lens and the electron beam are moved can also be employed.

[0081] An exemplary aspect of the method that can be varied to control the resulting RI profile of the lens is the angle of incidence of the electrons. In certain embodiments it is desirable that the electrons hit the lens at glancing angle (e.g., across the whole surface of the lens). This permits a higher energy to advantageously be employed, e.g., in preparing a surface layer. This can be viewed as controlling the amount of absorbed energy or the strength of the electron beam by controlling the angle of incidence. Figure 2 illustrates this concept, showing lens 20 and energy 22 hitting the lens at glancing (shallow) angles. Lens 20 may be moved relative to the energy source (now shown for simplicity), the energy source may be moved relative to the lens, or both the lens and energy source may be moved.

[0082] This application of ionizing energy (e.g., electron beams) differs from the irradiator described above for crosslinking (for forming the polymeric body) in that the ionizing energy in this step is directed in a specific pattern across the lens. Where the beam interacts with the polymeric material, bonds in the polymer backbone are broken, and the refractive index is changed when the polymeric body swells when placed in solution (e.g., BSS, aqueous). The resulting combinations of selected parameters can produce a GRIN in a material that is capable of withstanding steam sterilization (with water inside the material). Different absorbed doses of

radiation have a directly proportional effect on the swelling index, and the resulting effect on the polymer system provides the mechanism to form the GRIN.

[0083] Figures 3A, 3B, 4A and 4B illustrate generally how ionizing energy applied to a polymeric material can increase the amount of swelling when hydrated, and thus result in a greater reduction in RI. Figure 3A illustrates a formed polymeric material with crosslinks 30 generally indicated as squares (only three are labeled). This may be referred to as a “dry” state. Figure 3B illustrates the polymeric material when hydrated in solution (e.g., in BSS, magnesium, calcium, etc.). In figure 3B the polymeric material has swelled relative to its dry state in figure 3A. The positive charges 32 (only three labeled for clarity) repel each other.

[0084] Figure 4A illustrate a polymeric material after exposure to ionizing energy 40. As can be seen, some crosslinks 42 have been broken due to the exposure to the ionizing energy 41. Figure 4A, like figure 3A, can be referred to as dry state of the polymeric material.

[0085] Figure 4B illustrates the polymer after being hydrated in solution (e.g., in BSS, magnesium, calcium, etc.). As can be seen when comparing figure 3B and 4B, the polymeric material (at least where it was exposed to ionizing energy) swells to a greater extent after ionizing energy absorption compared to no exposure to ionizing energy.

[0086] Figure 5 illustrates in additional detail the manner in which swelling occurs. In the case of an IOL, the optical properties of the lens when the lens is positioned in the eye are of concern. The copolymer will increase its swell in solution in the presence of calcium and magnesium cations. As Ca^{2+} and Mg^{2+} ions are present inside the material due to diffusion from the solution in which the lens is positioned (e.g., aqueous humor), the swelling variation can be controlled in the lens. Greater swelling indicates more water in the matrix, and therefore a lower refractive index. Figure 5 illustrates the chemical processes involved for polymethylmethacrylate (PMMA), and can be modified for use with acrylates.

[0087] In the top left of the diagram, a pair of hydrogen bonds is shown between two methacrylate groups to indicate a weak crosslink. In the presence of Ca^{2+} and Mg^{2+} ions, there is the potential for stronger complexes to build as the cations bond with the oxygen atoms at the end of the methacrylate groups and create bundles of four or more weakly bonded units. These species are hydrophilic, and thus draw water into the matrix and cause swelling, in turn reducing the refractive index. When high energy electrons are incident upon the polymer, they may break polymer backbone bonds and, according to Flory-Huggins solution theory, cause additional swelling and thus a further decrease in the refractive index. In summary, the initial polymerization produces a hydrophilic polymer that swells in the presence of Ca^{2+} and Mg^{2+} ions. Irradiation with an electron beam (an example of which is shown in figure 4A) breaks

bonds in this synthetic polymer chain, and allows a change in RI (e.g., RI gradient) to be created. This technique can be used in any of the methods herein (e.g., creating an anti-reflective layer).

5 [0088] The lenses herein, after cross-linking, are generally referred to as being in a dry state. When placed in solution (e.g., BSS, aqueous of the eye), the polymeric material will swell relative to the dry state. The amount of swelling depends on the solution in which the lens is placed. Generally, a lens is packaged for shipping and/or storage, and is then implanted in an eye when ready for use. In some instances the lenses herein can be packaged in BSS (exposure to which causes some degree of swelling of the dry polymeric material), and once implanted they are exposed to aqueous, which may cause slight additional swelling.

10 [0089] Any of the lenses herein can be stored/packaged in a solution such that after implantation, the lenses undergo substantially no additional swelling. This may be beneficial if it is desired that the lens when implanted be as close to the final size as possible. For example, it may be desirable that a lens be implanted in a “full” size so that it is properly stabilized immediately when implanted.

15 [0090] Alternatively, it may be desired to implant a lens in a size that is smaller (i.e., less swelled) than in its final fully implanted size. For example, it may be desirable that an implanted lens be smaller so that it is easier to advance through a delivery tool, after which it expands to a greater extent to its final, implanted, size.

20 [0091] In this manner the degree of swelling post-implantation can be controlled as desired based on the application.

[0092] The general methods herein that utilize an electron beam to create a gradient refractive index profile in at least a portion of a lens can also be used to customize a lens to an individual patient. This approach provides a wide variety of possibilities, in that many patient needs can be met by using the techniques herein. A particular patient may benefit from a particular RI profile in the lens. The techniques herein can be tailored as needed to create the particular RI profile in the lens. These properties and others can be provided using the methods of the embodiments, contrary to single refractive index materials where optical properties are determined solely by the morphology of the lens.

25 [0093] While electron beams can advantageously be employed for surface or bulk modification, other energy may also be used, such as X-rays, leptons, protons, positrons, or ionizing radiation from radioactive sources such as from α or β sources.

30 [0094] There are a wide variety of specific applications of the general methods described herein. While some specific examples are provided herein, it is understood that the general methods can be used in other applications to create a desired RI profile for a wide variety of lenses.

35

[0095] One aspect of the disclosure is methods of manufacturing that fabricate lenses, such as intraocular lenses (e.g., IOLs, artificial replacement for the crystalline lens of the eye) with a multi-directional gradient of refractive index (GRIN) that can be controlled in magnitude and in a continuously varying multitude of ways. The GRIN lens material is dimensionally stable through steam sterilization as part of a "wet pack," and is hydrolytically stable during long term use. Since the GRIN of the lens is due to the lens material, with a narrow three-dimensional crosslinking distribution, it is unchanged during long term use. These methods of manufacturing enable lenses to be designed to solve many problems.

[0096] For example without limitation, an exemplary application of these methods is the creation of an anti-reflection layer in the lens by producing a thin layer of base material that has had its refractive index lowered. Figure 6 illustrates an exemplary lens with a thin anti-reflection layer formed therein, with main lens body portion.

[0097] An anti-reflection layer (i.e., a surface layer) may be useful because it reduces stray light within the eye that can cause dysphotopsia, and it also reduces unwanted reflections in lens applications other than IOLs.

[0098] Figures 13A and 13B illustrate an additional exemplary lens 100, including optic portion 102 and peripheral support 104. Optic portion 102 includes an aperture 106 (in this embodiment is a central aperture) extending through the optic portion 102. Figure 13B illustrates region 108 of the optic that forms the aperture that may be irradiated using methods herein to create an anti-reflection layer at the location of the aperture. This may help reduce the scattering of light at the location of the aperture.

[0099] The manufacturing processes described herein can be manipulated to form an anti-reflection layer. Generally, electrons having low energy (e.g., 500 eV up to 10 keV) and, optionally, high flux (high rate of flow of electrons through the surface), can be employed for surface modification of a lens. For example, an antireflective layer can be created by, for example, breaking chemical bonds at the surface whereby RI and/or reflectivity is reduced.

[0100] To create an antireflective layer, electrons in the range of 0.5 keV to 2 keV can be employed, with an absorbed radiation dose in the range of 4-8 Mrad. The dose may be higher or lower, and can also be dependent on the composition of the irradiated substrate chemical.

Alternatively, electrons with an energy of about 0.3 to 1 keV can be used with a high flux. Once the absorbed dose reaches about 8 Mrad, the change in refractive index through the irradiated depth will become substantially uniform and a layer (e.g., layer 52) that has approximately the same refractive index will be created at a 75% relative reduction. By selecting the energy and dose of the electrons appropriately, an interference antireflective layer can be created in the lens material.

[0101] The thickness of a modified surface layer is influenced primarily by the electron energy. This is illustrated in Figure 7, and is calculated according to the theoretical formula taken from Anderson, C. A., ed., 1973, *Microprobe Analysis*, John Wiley & Sons, 571 pp.

$$5 \quad R = \frac{0.064}{\rho E_0}$$

where R is the maximum penetration depth of the electrons in microns, ρ is the density of the material in g/ml and E_0 is the energy of electrons upon impact with the surface in keV.

[0102] If the change in refractive index is a step, then the desired thickness is one quarter of the wavelength of light in the modified surface layer, which is reduced from the wavelength in air by a factor equal to the RI. Accordingly, the layer will be about 100 to 200 nm in thickness. Using a single electron energy, the actual RI change is an exponential decay. As such, the thickness in some embodiments may be somewhat smaller or larger than from about 100 to 200 nm, e.g., from about 50 to 400 nm, wherein the thickness is defined as $1/e$ of the maximum RI change. In some embodiments the thickness is 0.1 microns to 10 microns. In some
15
embodiments the thickness is 1 micron to 10 micron. A more step-like layer can be created by varying the electron energy during exposure. Moreover, the angle of incidence of light onto the lens's curved surface can be taken into consideration by varying the thickness of the surface layer as a function of the distance from the center of the lens.

[0103] While the disclosure herein mainly describes electron beams as the ionizing energy, other types of ionizing energy, such as beta radiation, may be used. However, beta radiation is typically of higher energy (e.g., $^{90}\text{Sr} \rightarrow ^{90}\text{Y}$ at 546 keV) and its use can be limited by the thickness of the layer desired or, for applications other than anti-reflection layers, by the thickness of the lens itself. For an IOL, this thickness is between 0.05 mm and 5 mm. Also, the energy of beta radiation cannot be tuned, unlike electron radiation. When compared to the electron radiation graph shown in figure 7, figure 8 illustrates the relatively higher energy range for beta radiation.
20
25

[0104] An additional exemplary application is to create lenses that focus light from a wide range of distances without moving or changing shape whereby light entering the lens from different directions and incident on different surface positions on the lens will experience optical pathways through the lens that differ due to RI variations throughout the lens. Focusing light from a wide range of distances is useful to patients fitted with the lens, as IOLs do not typically provide accommodation similar to that provided by the native crystalline lens. Additionally, the technology can be useful in other lens applications, such as camera lenses designed with a large depth of field.
30

[0105] The change in refractive index for the surface lens material relative to the bulk lens material depends on the absorbed radiation dose. Figure 9 shows the percentage change in refractive index, wherein 100% refers to a surface RI unchanged from the bulk and 0% refers to the surface RI being reduced to the RI of the solution in which it is held (e.g., a balanced salt solution in packaging, aqueous humor in the eye).

[0106] Another exemplary application of the general technique described herein is creating an extended surface layer over a thickness of several wavelengths that does not cause destructive interference of light reflected from both surfaces. This can be represented by figure 6, but region 52 would be a gradient RI rather than a layer with a uniform RI. In this exemplary method, the RI of the outer surface of the material is reduced to match as closely as possible (e.g., 10% or less variance, such as 5% or less variance) the RI of aqueous humor. The small change in RI between the lens and aqueous humor results in less reflection. According to Fresnel's equations the proportion of reflected power for normal incidence light = $\frac{(n_l - n_a)^2}{(n_l + n_a)^2}$

where n_l is the refractive index of the lens and n_a is the refractive index of aqueous humor. This method utilizes a surface dose of about 8 Mrad or more but layers directly below the surface receive less radiation thus creating a gradual variation in refractive index. The time required to create such a gradient must therefore be selected to prevent saturation as described above.

Achieving the thicker surface layer requires higher energy electrons in the range of 1 keV to 10 keV, but still in the range of "low" energy as defined herein.

[0107] Multiple directional incidence angles of irradiation can be used to create different three-dimensional (3D) patterns of the gradient refractive index in the bulk of the lens, or on the surface of the lens, or both. Regardless of orientation, the change in RI is determined by electron energy (penetration) and absorbed dose (magnitude of effect), such that different patterns can be achieved by varying the lens-beam orientation. Predictions of the effect can be made by calculating, for all the positions in the 3D matrix, how deep the position is within the lens relative to the direction of the electron beam and the absorbed dose at that position, and integrating over time as the beam is moved.

[0108] The aforementioned methodology is particularly useful in the surface modification of a lens, examples of which have been described herein. When modification of the bulk of the lens (i.e., more than just the surface) is desired, however, high energy (e.g., from 10 keV to 700 keV, inclusive) electrons can be employed for penetration deeper into the bulk of the lens. The energy of the beam can thus be modified as needed to penetrate to the depth(s) desired for a particular application. By adjusting the energy profile and flux of the electrons, as well as the angle of incidence and location of irradiation, a desired RI profile throughout any portion of the lens can be achieved.

[0109] Generally, retinal images that are similar to those provided by the natural crystalline lens may be advantageous to the lens recipient, as the brain has grown accustomed to such images and the brain's neural networks may better be able to process such images. An additional exemplary application of the methods herein is to create a lens that produces images that are more similar to those produced by the natural crystalline lens. Figure 10 illustrates exemplary lens 60 that can be created using methods herein. Lens 60 is created to function like the natural crystalline lens, with a gradually changing RI as indicated by the internal lines that represent refractive index contours in the figure. Lens 60 may be implanted in a capsular bag to replace a removed native crystalline lens. In figure 10, anterior is towards the bottom of the page, and posterior is towards the top of the page. The RI varies in the lens body, with the RI being greater in central region 62 than in outer region 64. Lens 60 is an example of an optic body that has a three-dimensional polymeric matrix with a refractive index distribution substantially the same as a refractive index distribution of a natural crystalline lens. Lens 60 is also an example of an optic body that has a shape that is substantially the same as a shape of a natural crystalline lens. One of skill in the art will understand that the comparison to a native crystalline lens (for which there may be some subject to subject variability) does not render this description indefinite or vague, since one of ordinary skill in the art will understand what is meant by a refractive index distribution substantially the same as a refractive index distribution of a natural crystalline lens, as well as a shape that is substantially the same as a natural crystalline lens.

[0110] The lens 60 in figure 10 is an example of a lens that can be adapted so that it swells to a final implanted state (size) after implantation. For example, it may be desirable that lens 60 have a smaller delivery size to ease the delivery through a lens inserter, then swell (expand) to a greater state once inserted so that it is better secured within the eye (e.g., within a capsular bag).

[0111] Figure 11 illustrates an alternative optic body 70 with a varying RI in the optic body that can be created using the methods herein. Optic body 70 can be incorporated into any suitable ophthalmic lens (e.g., an IOL with one or more haptics). Ionizing energy can be applied to a polymeric body to create optic body 70. Region 74 may be considered a lower RI region compared to regions 72. The RI may vary continuously (gradient) through the lens 70. Lens 70 is an example of a lens that is configured to treat ametropia (via a spherical component of the lens shape) and astigmatism (via a cylindrical component of the lens shape). The degree of change in RI between regions 72 and 74 can be any suitable degree.

[0112] A further embodiment of the methods described herein is the creation of an embedded Fresnel lens within a conventionally shaped lens, e.g., a bi-convex lens or a bi-concave lens. To create optical power, lens surfaces need to be curved. In the case of a biconvex lens this means

that the center has to have a central thickness that increases with optical power and for a biconcave lens the edge thickness that increases with optical power. A Fresnel lens has a shape that segments the curvatures into different sectors thus reducing the thickness of the lens. One disadvantage of a Fresnel lens is that it can have sharply changing curvatures that can scatter light. By producing the Fresnel lens within a conventionally shaped lens, some of the power can come from the outer shape of the conventional lens and more power can be obtained by replicating a Fresnel lens within the conventional lens by creating curved zones of increased power. Furthermore, Fresnel lenses can be designed to have more than one focus to provide simultaneously, for instance, good focus at far distance and near, or good focus at far distance and near and an intermediate distance. Furthermore, the interaction between the different refractive zones of the Fresnel lens can create beneficial diffractive effects and control of the exact shape of the refractive zones can reduce scatter and create better images.

[0113] One aspect of this disclosure is a copolymer material or a combination of copolymer materials that can be used to make a GRIN lens. The lens can be incorporated into, e.g., an IOL. Properties of IOL materials include high elasticity to allow ease of insertion into the eye, low reflectivity to avoid dysphotopsia, good biocompatibility (e.g., does not leech toxic materials into the eye), and be mechanically capable of accurately holding a stable shape that is composed of a lens and supporting elements without disturbing or irritating the existing structure of the eye.

[0114] Some ophthalmic devices may include one or more peripheral supports (e.g., one or more haptics, such as plate haptics or arm haptics) that extend radially outward from an optic, and provide support to the optic when placed in an eye. Any of the methods of irradiating herein may occur after the optic and any peripheral support(s) have been formed into an integral structure (e.g. via lathing, molding, machining, or any combination thereof).

[0115] The methods of creating non-uniform cross-link densities herein may also be used on non-optic body portions (e.g., one or more haptics) of a lens. At least a portion of the non-optic body portion may also be irradiated to create a varying refractive index. This may be helpful to reduce light scattering in some subjects who have relatively larger pupils, where more light passes through the non-optic portion due to the larger pupil size. All of the methods of irradiating and swelling described herein may thus also be used on a non-optic portion of a lens, as well as on an optic body.

Exemplary Method of Preparing a Gradient Refractive Index in a Three-Dimensional Copolymer

[0116] The copolymer system of certain embodiments is composed of a large proportion of a non-ionic acrylic monomer and a small proportion of an ionic monomer such as an organic acid. The term "organic acid" encompasses acids made up of molecules containing

organic radicals ((hydro)carbon containing moieties). Such acids include, for example, acrylic acid, formic acid (H-COOH), acetic acid (CH₃COOH) and citric acid (C₆H₈O₇), each of which contain the ionizable -COOH group. The term “acrylic” as applied to monomers includes synthetic plastic resins derived from acrylic acids. The present hydrophilic monomers and hydrophobic monomers must be selected such that the hydrophobic monomer(s) is soluble in the hydrophilic monomer(s). The hydrophilic monomer acts as a solvent for the hydrophobic monomer. Suitable monomers can be readily selected by those of ordinary skill in the art to which the present disclosure pertains. Examples of suitable acrylic monomers, include 4-methacryloxy-2-hydroxybenzophenone, ethyl-3-benzoil acrylate, N-propyl methacrylate) N-propyl methacrylate (acrylic), ethyl-methacrylate, methyl methacrylate, n-heptyl methacrylate, 2-hydroxyethyl methacrylate (HEMA), hydroxypropyl methacrylate, 2-hydroxyethyl methacrylate, hydroxypropyl methacrylate poly(ethylene glycol)n monomethacrylate, 4-hydroxybutyl methacrylate, and other monomers as are known in the art. It is generally observed that swelling in water is reduced when sodium chloride or other salts are present in the copolymer system.

The targeted amount of swelling can therefore be modified by manipulating salt content within the copolymer system when the lens is outside of the eye. The lens can expand more or less once implanted in the eye when exposed to aqueous, depending on the solution in which it is placed prior to implantation.

Gradient Refractive Index in a Three-Dimensional Collagen-Containing Copolymer

[0117] Copolymers can be modified by adding collagen or a similar biological molecule to the polymer, in which case the radiation method can be employed. This formulation method provides the structural and dimensional characteristics of the resulting material from which an IOL with GRIN can be produced. Any type of collagen from any source can be employed. Suitable collagen materials include, but are not limited to, collagen obtained from pig's eye sclera or cornea, or fibroblasts (e.g., artificially produced or cultured from genetically modified yeast, etc.). The collagen is a naturally stable polyenic, which comprises hydrophobic, hydroxylic and polarized amino-acids, e.g., telo-collagen. Copolymeric materials comprising collagen materials are described in U.S. Pat. No. 5,654,349, U.S. Pat. No. 5,910,537, U.S. Pat. No. 5,661,218. Collamer can be desirable in certain embodiments due to its stability to radiation.

Hydrogels are associated with calcification (hydroxyapatite deposition). Biological molecules such as denatured collagen, when incorporated into the lens, can attract fibronectin, forming a protective layer. This protective layer of fibronectin (unique to an individual patient) is not recognized as a foreign body, thereby reducing the susceptibility of the lens to calcification. Accordingly, providing materials that are radiologically resistant and biologically active as

components of the lens can yield a lens having superior stability, in particular to optical degradation, and biocompatibility.

[0118] Forming a polymeric body may include mixing a nonionic acrylic monomer with the ionic monomer (e.g., an acid such as formic acid). The weight ratio of nonionic acrylic monomer to ionic monomer can be in the range of about 10:1 to about 10,000:1, e.g., 50:1 to 200:1, e.g., 75:1, 100:1, 125:1, 150:1, or 175:1. Additional steps in an exemplary method of preparing an exemplary material may be described in U.S. App. No. 62/765,088, whose priority is claimed herein, and the disclosure of which is incorporated by reference herein for all purposes.

10 [0119] Accordingly, once the polymer is formed, an IOL (or other lens) can be manufactured in a traditional manner using, for example, a lathe and mill or with a mold, and can then be modified using a second irradiation process.

[0120] The change in RI as a function of radiation absorbed is influenced by factors, such as the concentration of anionic components, such as methacrylic acid and acrylic acid, which are crosslinked into the copolymer. The concentration of the anionic components influence the swell factor, which in turn influences RI. More swelling correlates with a lower RI, and a higher concentration of the anionic components results in more swelling (and thus lower RI). The concentration of bi-cations in physiological and BSS ranges are as follows: magnesium 0.7-2.0 mmol/L and calcium 1-3.5 mmol/L. The propensity for the material to swell is determined by anionic components, such as methacrylic acid and acrylic acid, that are crosslinked into the copolymer. Excess monomers are typically removed during the extraction process.

[0121] The ratios of the two different monomers within the copolymer structure, the absorbed dose, and the electron energy can be varied within moderate ranges to achieve different balances of properties within the resulting GRIN lens. In this way, a desired RI profile can be created in the lens. As an example, the optical aberrations of a patient's visual system can be measured using a device such as a wavefront aberrometer and the required lens correcting for the aberrations can be calculated. Thereafter, a three-dimensional irradiation plan can be developed whereby the dose at any point in the lens, as a function of electron energy, can be calculated and an irradiation plan, consisting of beam position and angle, electron flux and electron energy, can be produced. Lenses for different patients can be produced from one single design of a single refractive index lens or the geometrical properties of the lens can be used as additional degrees of freedom (design parameters). There is thus great flexibility in how the methods herein can be used to create a wide variety of lenses based on the desired refractive index profile.

[0122] The following references relate to use of lasers to modify refractive index of lenses: U.S. Patent No. 9,545,340; U.S. Patent No. 9,492,323; U.S. Patent No. 9,144,491; U.S.

Patent No. 9,060,847; U.S. Patent No. 8,932,352; U.S. Patent No. 8,901,190; U.S. Patent No. 8,617,147; U.S. Patent No. 8,512,320; U.S. Patent No. 8,486,055; U.S. Patent No. 8,337,553; and U.S. Patent No. 7,789,910, all of which are incorporated by reference herein.

5 Examples

[0123] An exemplary polymer may be a structural copolymer produced from hydroxyethylmethacrylate monomers as a major component and acrylic acid as a minor component. The weight ratio may be as indicated above. Figure 12 shows such a portion of a polymer chain with the acrylic acid side group (left) and methacrylate side group (right). The copolymer is produced either chemically or during nuclear irradiation (described above), and then amended using the electron beam irradiation methods (or other ionizing energy source) described herein to create the GRIN lens.

[0124] Following the generalized formula presented above, other copolymer combinations can be used to achieve the same final properties. An absorbed dose radiation sensitive refractive index changing copolymer composition comprising a methacrylic ionic monomer and a methacrylic nonionic monomer that is sensitive to electron beam bombardment can be employed in preparing materials with varying refractive index that are also compatible with use in the eye.

[0125] The term “low energy” as used herein is a broad term, and refers without limitation to 500 eV to 10 keV, inclusive.

[0126] The term “high energy” as used herein is a broad term, and refers without limitation to 10 keV to 700 keV, inclusive.

[0127] The description herein and examples illustrate exemplary embodiments of the present disclosure in detail. Those of skill in the art will recognize that there are numerous variations and modifications of the inventions herein that are encompassed by its scope. Accordingly, the description of exemplary embodiments should not be deemed to limit the scope of the inventions herein.

[0128] The illustrative embodiments described in the detailed description, drawings, and claims are not meant to be limiting. The teachings herein can be applied in a multitude of different ways, including for example, as defined and covered by the claims. It should be apparent that the aspects herein may be embodied in a wide variety of forms and that any specific structure, function, or both being disclosed herein is merely representative. Based on the teachings herein one skilled in the art should appreciate that an aspect disclosed herein may be implemented independently of any other aspect and that two or more of these aspects may be combined in various ways. For example, a system or apparatus may be implemented or a

method may be practiced by one of skill in the art using any reasonable number or combination of the aspects set forth herein. In addition, such a system or apparatus may be implemented, or such a method may be practiced using other structure, functionality, or structure and functionality in addition to or other than one or more of the aspects set forth herein. Other
5 embodiments may be utilized, and other changes may be made, without departing from the spirit or scope of the subject matter presented herein. It will be readily understood that the aspects of the present disclosure, as generally described herein, and illustrated in the Figures, can be arranged, substituted, combined, and designed in a wide variety of different configurations, all of which are explicitly contemplated and made part of this disclosure. It is to be understood that
10 the disclosed embodiments are not limited to the examples described below, as other embodiments may fall within the disclosure and the claims.

[0129] While the disclosure has been illustrated and described in detail in the drawings and foregoing description, such illustration and description are to be considered illustrative or exemplary and not restrictive. The disclosure is not limited to the disclosed embodiments.
15 Variations to the disclosed embodiments can be understood and effected by those skilled in the art in practicing the claimed disclosure, from a study of the drawings, the disclosure and the appended claims.

[0130] All references cited herein are incorporated herein by reference in their entirety. To the extent publications and patents or patent applications incorporated by reference contradict
20 the disclosure contained in the specification, the specification is intended to supersede and/or take precedence over any such contradictory material.

[0131] Where a range of values is provided, it is understood that the upper and lower limit, and each intervening value between the upper and lower limit of the range is encompassed within the embodiments.

[0132] Furthermore, in those instances where a convention analogous to “at least one of A, B, and C, etc.” is used, in general such a construction is intended in the sense one having skill in the art would understand the convention (e.g., “a system having at least one of A, B, and C” would include but not be limited to systems that have A alone, B alone, C alone, A and B together, A and C together, B and C together, and/or A, B, and C together, etc.). In those instances
30 where a convention analogous to “at least one of A, B, or C, etc.” is used, in general such a construction is intended in the sense one having skill in the art would understand the convention (e.g., “a system having at least one of A, B, or C” would include but not be limited to systems that have A alone, B alone, C alone, A and B together, A and C together, B and C together, and/or A, B, and C together, etc.). .

What is claimed is:

1. An ophthalmic lens, comprising:
an optic body made from a copolymer having a three-dimensional polymeric matrix,
5 wherein the three dimensional polymeric matrix of the copolymer has a non-uniform
cross-link density.
2. The lens of Claim 1, wherein the three dimensional polymeric matrix includes a first
region with fewer cross links than a second region.
- 10 3. The lens of Claim 2, wherein the first region and the second region are within a gradient
of cross-link density.
4. The lens of Claim 2, wherein the three dimensional polymeric matrix includes further
15 includes a third region that is not within the gradient, the third region including a layer having a
uniform cross-link density.
5. The lens of Claim 3, wherein the first region is closer to a periphery of the optic body
than the second region.
- 20 6. The lens of Claim 2, wherein the first region is in a first layer with a first cross-link
density, and the second region is in a second layer with a second cross-link density.
7. The lens of Claim 6, wherein the first region is a surface layer of the optic body, the first
25 region having fewer cross-links than the second region.
8. The lens of Claim 2, wherein the first region is closer to a periphery of the optic body.
9. The lens of Claim 2, wherein the entire optic body has a gradient cross-link density.
- 30 10. The lens of Claim 2, wherein the three-dimensional polymeric matrix has a refractive
index distribution substantially the same as a refractive index distribution of a natural crystalline
lens.

11. The lens of Claim 2 or Claim 10, wherein a shape of the optic body is substantially the same as a shape of a natural crystalline lens.
12. The lens of Claim 2, wherein the entire optic body does not have a gradient cross-link
5 density.
13. The lens of Claim 2, wherein the optic body is a toric lens.
14. The lens of claim 2, wherein the copolymer includes at least one non-ionic acrylic
10 monomer and at least one ionic monomer.
15. The lens of claim 14, wherein the copolymer further comprises a collagen material.
- 15 16. The lens of claim 14, wherein the ionic monomer is an organic acid.
17. The lens of claim 14, wherein the weight ratio of the non-ionic acrylic monomer to the ionic monomer is 10:1 to 10,000:1, such as 50:1 to 200:1, such as 75:1 to 175:1, such as 75:1, 100:1, 125:1, 150:1, or 175:1.
20
18. The lens of claim 14, wherein the non-ionic acrylic monomer is hydroxyethylmethacrylate.
19. The lens of claim 1, wherein the non-uniform crosslink density of the matrix is adapted to
25 create an anti-reflection surface layer in the optic body when the optic body is exposed to aqueous in an eye.
20. The lens of claim 19, wherein the anti-reflection layer comprises a region of the matrix that is 50 nm to 400 nm thick.
30
21. The lens of claim 19, wherein the anti-reflection layer comprises a region of the matrix that is .1 micron to 10 microns thick.
22. The lens of claim 19, wherein the anti-reflection layer comprises a region of the matrix that
35 is 1 micron to 100 microns thick.

23. The lens of claim 19, wherein the anti-reflection surface layer is at least partially disposed around a central aperture formed in the optic body.
- 5 24. The lens of claim 2, wherein the optic body is an optic body of an IOL.
25. The lens of claim 2, wherein the three-dimensional matrix is dimensionally stable through steam sterilization as part of a "wet pack" and is hydrolytically stable during long term use.
- 10 26. The lens of claim 2, wherein the non-uniform cross-link density adapts the optic body, when placed in an eye and exposed to aqueous, to focus light from a wide range of distances without moving or changing shape, optionally with a vergence of 0 to 3 D, optionally 0 to 2.5 D, optionally 0 to 2 D, optionally 0 to 1.5 D, optionally 0 to 1.0 D.
- 15 27. The lens of claim 2, wherein the non-uniform cross-link density adapts the optic body, when placed in an eye and exposed to aqueous, to correct for astigmatism.
- 20 28. The lens of claim 2, wherein the three dimensional polymeric matrix has a lower cross-link density near a surface of the optic body than in a region further inward relative to the surface.
- 25 29. The lens of claim 2, wherein the lens further comprises a non-optic body portion (e.g., one or more haptics), and wherein the non-optic body portion includes a non-optic three-dimensional polymeric matrix, wherein the non-optic three dimensional polymeric matrix has a non-uniform cross-link density.
- 30 30. The ophthalmic lens of claim 1, further comprising a hydrating solution to which the optic body is exposed, wherein the non-uniform cross-link density causes the three-dimensional polymeric matrix to swell in a non-uniform manner when hydrated in the solution, thereby creating a non-uniform refractive index within the optic body.
31. The lens of Claim 30, wherein the hydrating solution is a balanced salt solution.

32. The lens of Claim 30, wherein hydrating solution includes constituent parts such that when the lens is exposed to aqueous humor in an eye, the amount of swelling in the three-dimensional polymeric matrix will not substantially change.
- 5 33. The lens of Claim 32, wherein the hydrating solution is a balanced salt solution.
34. The lens of Claim 30, wherein hydrating solution includes constituent parts such that when the lens is exposed to aqueous humor in an eye, the amount of swelling in the three-dimensional polymeric matrix increases.
- 10 35. The lens of claim 34, wherein the hydrating solution is a sodium chloride solution.
36. The lens of Claim 30, wherein hydrating solution includes constituent parts such that when the lens is exposed to aqueous humor in an eye, the amount of swelling in the three-dimensional polymeric matrix decreases.
- 15 37. The lens of Claim 30, wherein the hydrating solution includes at least one of magnesium ions or calcium ions.
- 20 38. The lens of Claim 30, wherein the non-uniform refractive index includes first and second discrete layers having first and second refractive indices, respectively.
39. The lens of Claim 30, wherein the non-uniform cross-link density includes a gradient cross-link density.
- 25 40. A method of placing any of the lenses in Claims 1-39 in a hydrating solution, wherein placing the lens in the hydrating solution causes a non-uniform swelling of the matrix, thereby creating a non-uniform refractive index in the optic body.
- 30 41. The method of claim 40, wherein the hydrating solution is a balanced salt solution.
42. A method of implanting any of the lenses of claims 1-39, wherein the method of implanting causes a change in the swelling in the matrix.

43. The method of Claim 42, wherein implanting causes the matrix to swell more in at least a portion of the matrix.
44. The method of Claim 42, wherein implanting causes a decrease in swelling in at least a portion of the matrix.
45. The method of Claim 42, wherein implanting the lens causes the lens to increase in overall volume to an implanted configuration.
46. A method of implanting any of the lenses of claims 1-39, wherein the method of implanting does not causes a substantial change in the swelling in the matrix.
47. A method of implanting any of the lenses of claims 1-39, wherein implanting the lens comprises inserting the lens through a delivery device in a state in which the lens has a smaller volume than a volume in a fully hydrated, implanted state.
48. A method for inducing a refractive index gradient in a three-dimensional polymeric matrix, the method comprising:
providing a formed body having a three-dimensional polymeric matrix comprising a copolymer system prepared from at least one non-ionic acrylic monomer and at least one ionic monomer;
irradiating the three-dimensional polymeric matrix with ionizing energy in a pattern configured to thereby create a non-uniform cross-link density within the matrix.
49. The method of Claim 48, wherein the matrix is any of the matrices in claims 1-39.
50. The method of Claim 48, wherein the ionizing energy is electron beams.
51. The method of Claim 48, further comprising maintaining the body in a stationary position, and wherein irradiating comprises moving an ionizing energy source in at least one direction.
52. The method of Claim 48, further comprising:
maintaining an ionizing energy source in a stationary position; and
moving the body in at least one direction during the irradiating step.

53. The method of claim 48, wherein the irradiating step creates a gradient of cross-link density in at least a portion of the matrix.
54. The method of claim 53, wherein the irradiating step creates a gradient of cross-link density in substantially the entire matrix.
55. The method of Claim 48, wherein the irradiating step creates a first layer with a first cross-link density less than a cross-link density of a second region the matrix.
56. The method of claim 55, where the first layer is a surface layer of the body.
57. The method of Claim 48, wherein the copolymer system further comprises a collagen material.
58. The method of Claim 48, wherein the ionic monomer is an organic acid.
59. The method of Claim 48, wherein the at least one non-ionic acrylic monomer is hydroxyethylmethacrylate and wherein the at least one ionic monomer is an acrylic monomer.
60. The method of Claim 48, wherein the body is an optic body of an intraocular lens.
61. The method of Claim 48, wherein the irradiated three-dimensional polymeric matrix is dimensionally stable through steam sterilization as part of a "wet pack" and is hydrolytically stable during long term use.
62. The method of Claim 48, wherein the irradiating step creates a surface anti-reflective layer, optionally from 50 nm to 400 nm thick, optionally from .1 microns to 10 microns thick, or optionally from 1 micron to 100 microns thick.
63. The method of Claim 48, wherein the irradiating step creates a non-uniform cross-link density such that, when the body is hydrated in aqueous in an eye, the body is adapted to focus light from a wide range of distances without moving or changing shape, optionally with a vergence of 0 to 3 D, optionally 0 to 2.5D, optionally 0 to 2D, optionally 0 to 1.5 D.

64. The method of claim 48, wherein the irradiating step is initiated after one or more peripheral support (e.g., haptics) have already been formed integrally with the formed body.

65. The method of Claim 48, wherein the ionizing energy is X-rays.

5

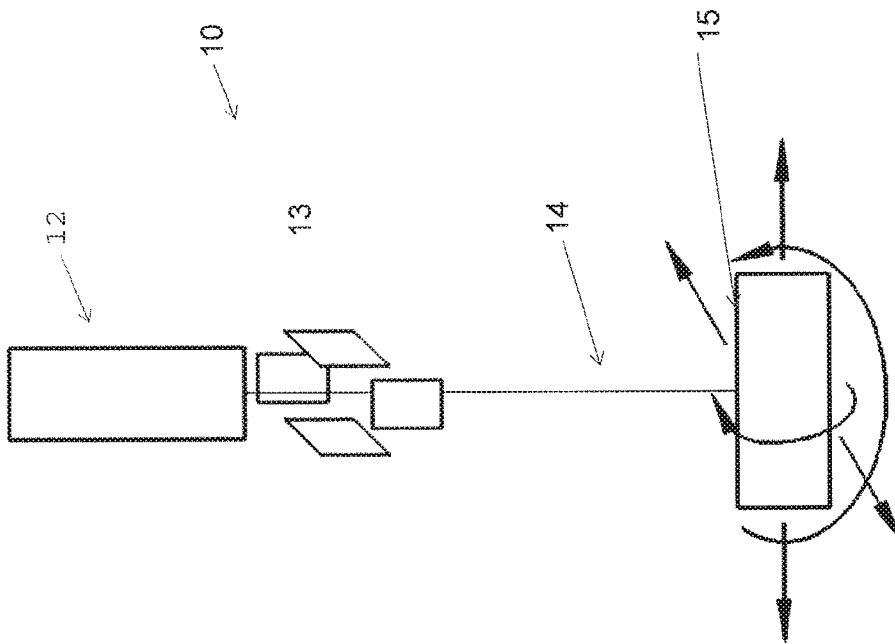

Fig. 1

Fig. 2

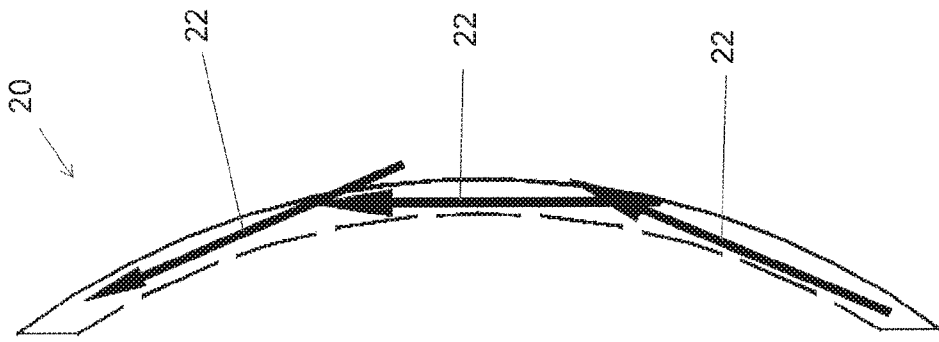

Fig. 3A

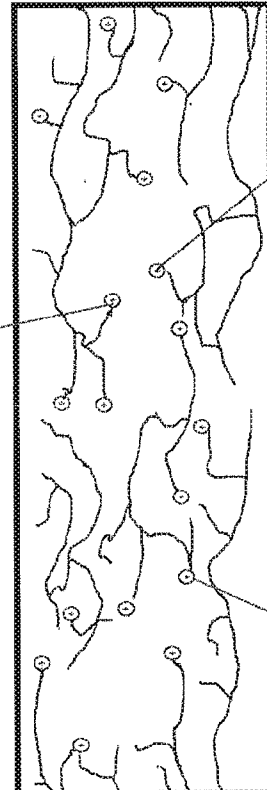
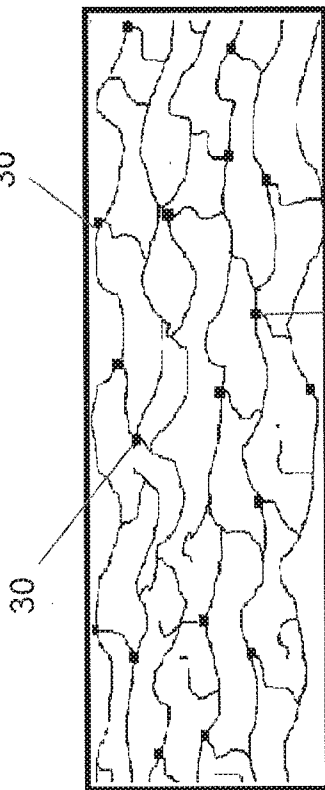
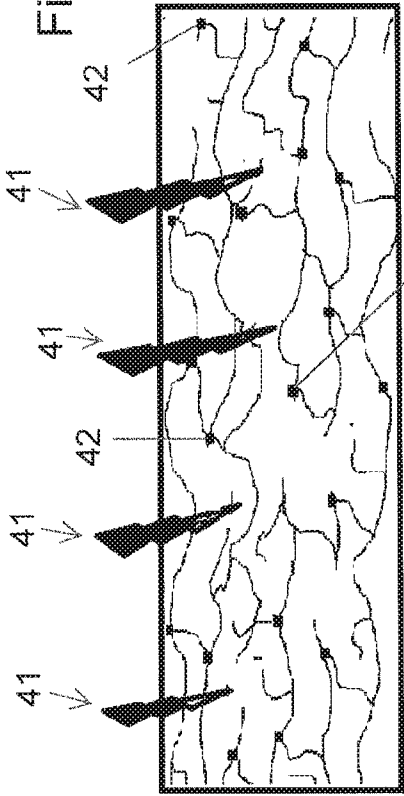

Fig. 3B

Fig. 4A



3 / 10

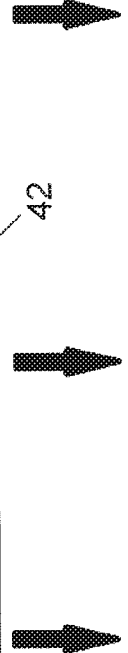
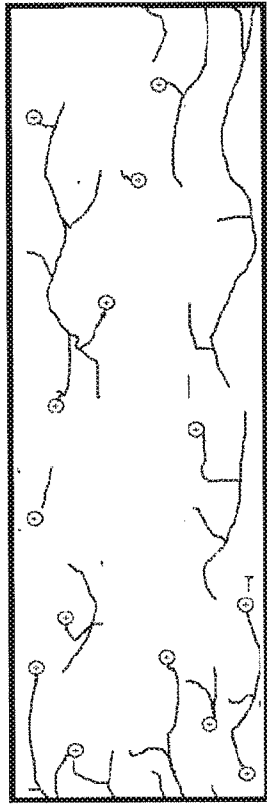
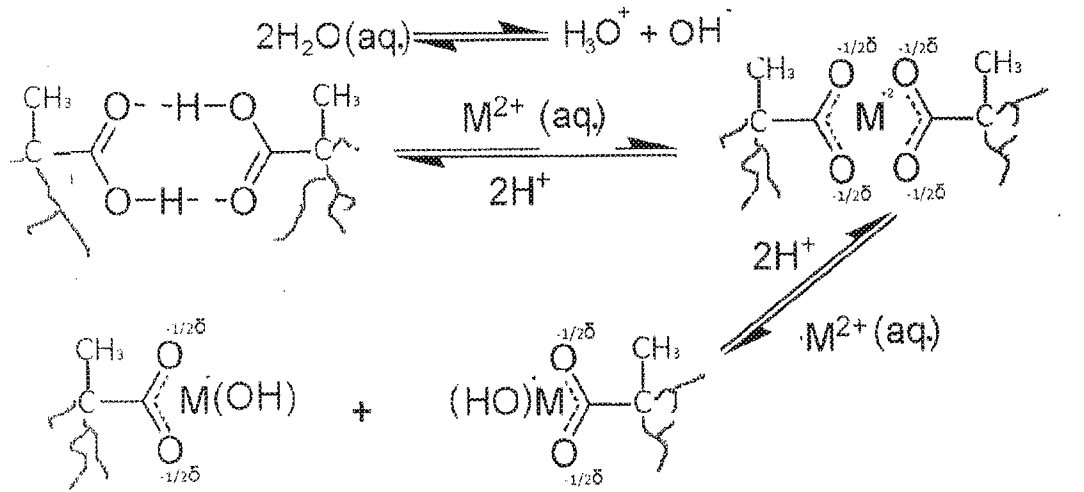

Fig. 4B





Decrease in chain intermolecular forces (due to repulsion) = increase in swelling



{ = random fragments of copolymer chains

Figure 5

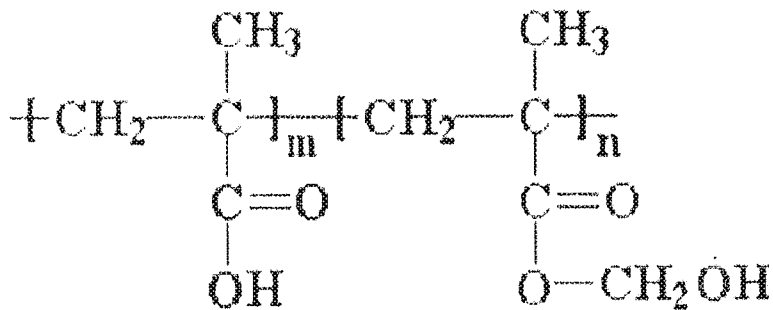

Figure 12

Figure 6

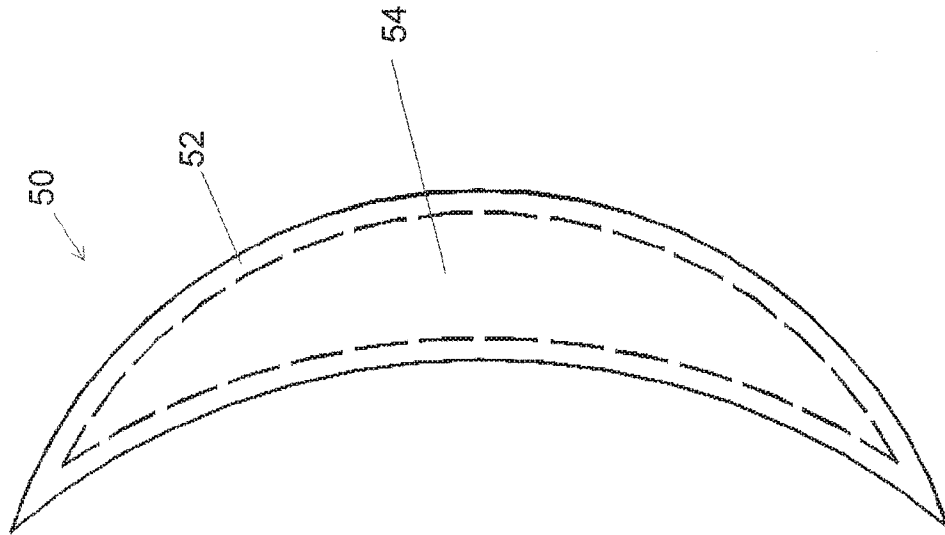

Figure 7

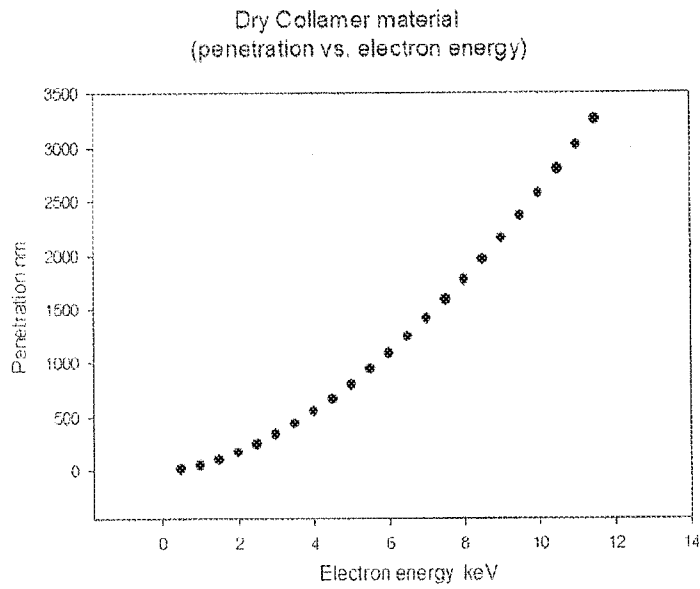

Figure 8

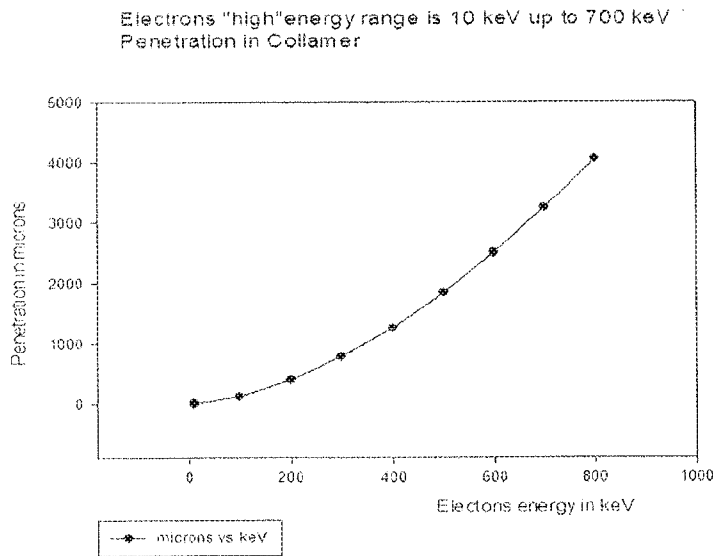
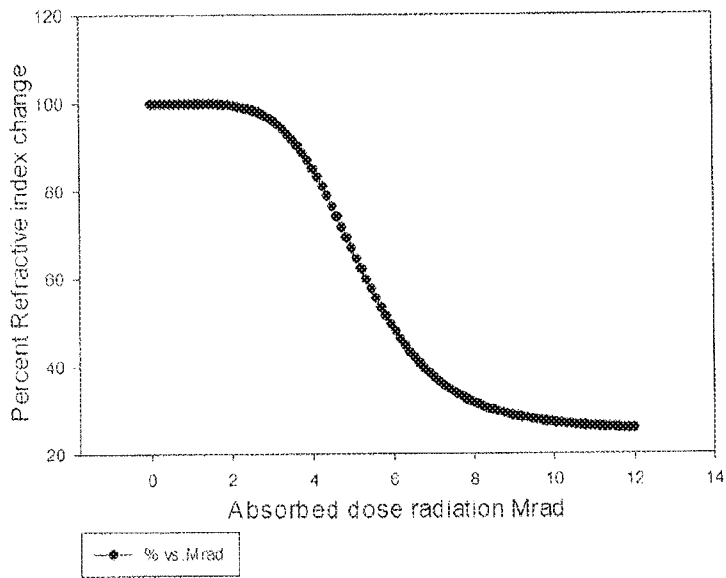

Figure 9

Percent Refractive index change in media RI = 1.336 vs. Absorbed dose radiation Mrad



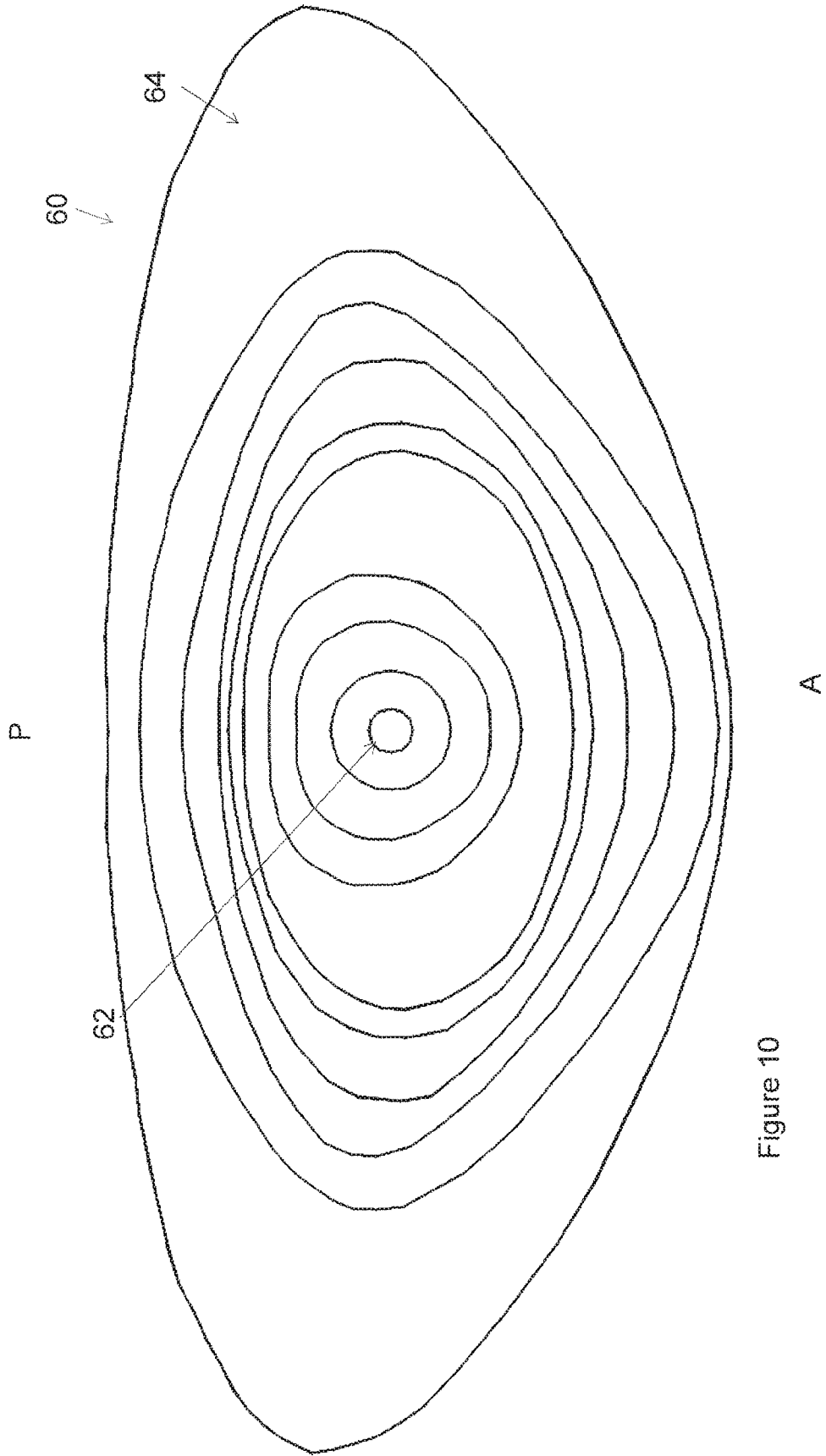

Figure 10

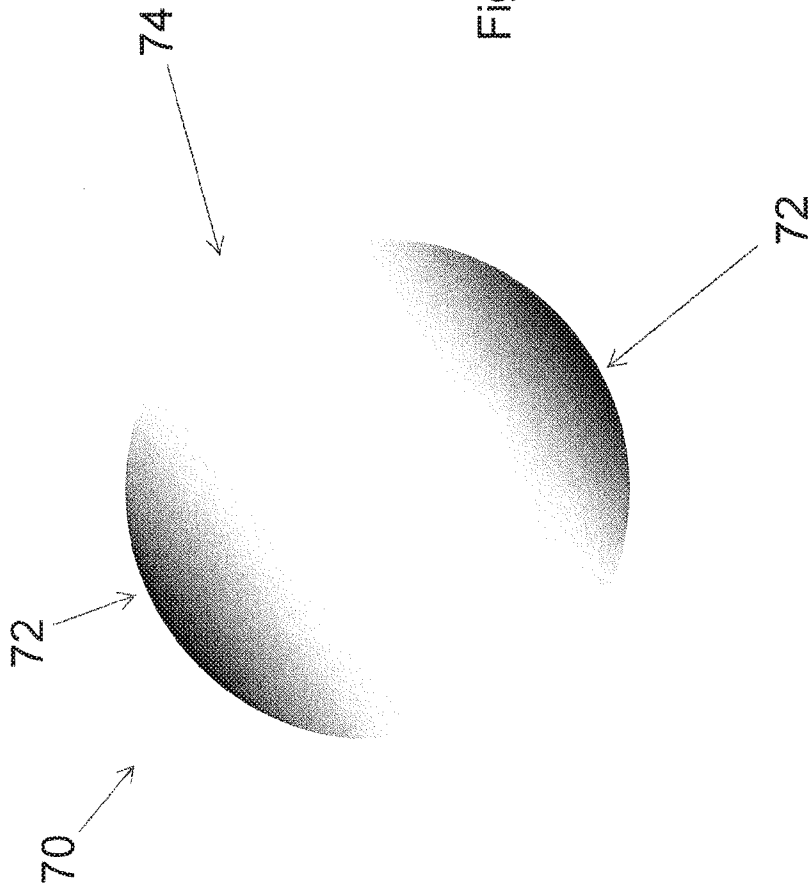

Figure 11

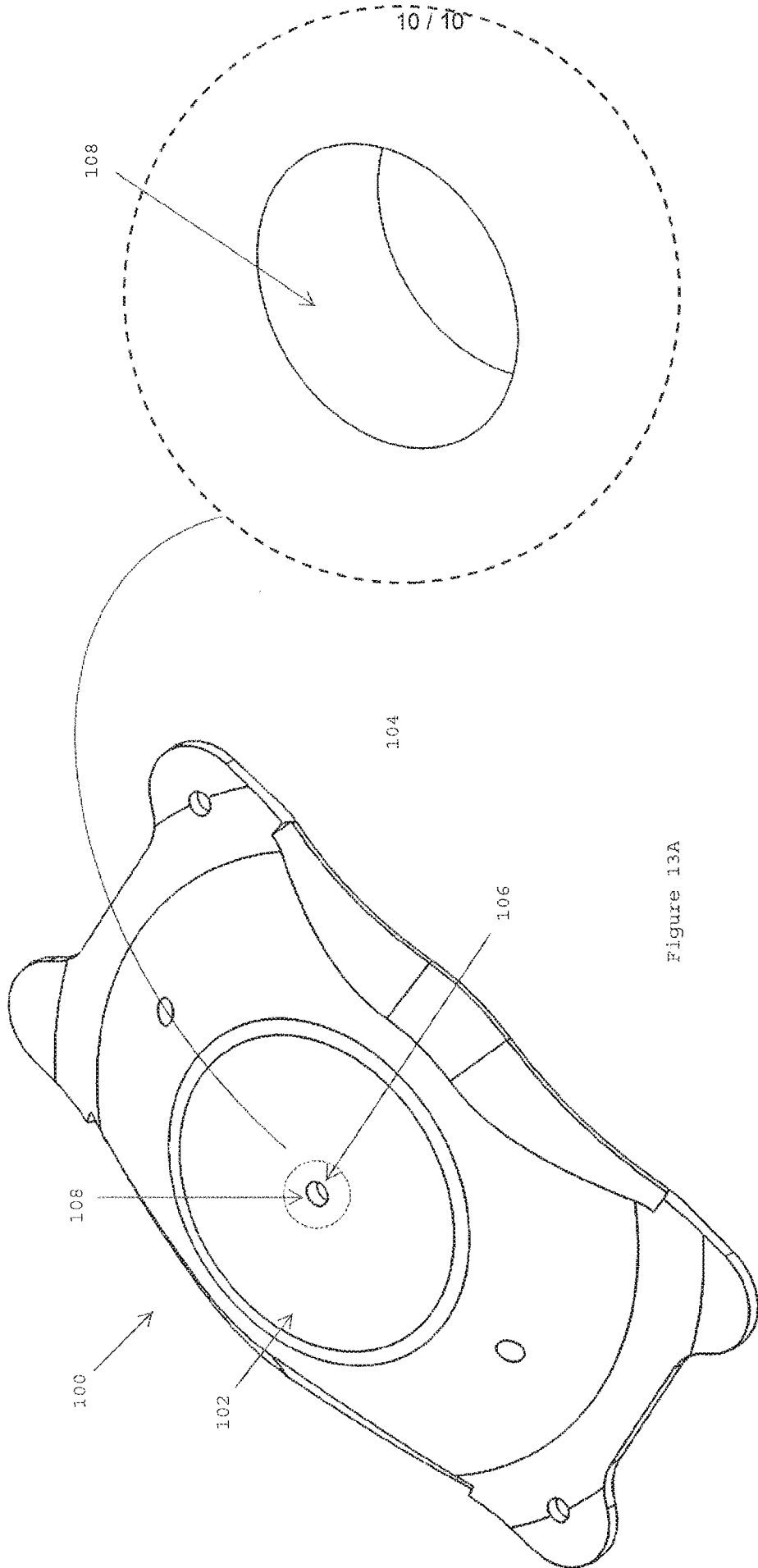

Figure 13A

Figure 13B

INTERNATIONAL SEARCH REPORT

International application No.
PCT/US2019/047058

A. CLASSIFICATION OF SUBJECT MATTER
IPC(8) - G02B 1/04; G02C 7/02; G02C 7/04 (2019.01)
CPC - G02B 1/043; G02C 7/022; G02C 7/04; G02C 7/049 (2019.08)

According to International Patent Classification (IPC) or to both national classification and IPC

B. FIELDS SEARCHED

Minimum documentation searched (classification system followed by classification symbols)
See Search History document

Documentation searched other than minimum documentation to the extent that such documents are included in the fields searched
USPC - 351/159.07; 351/159.1; 351/159.21; 351/159.22; 351/159.38 (keyword delimited)

Electronic data base consulted during the international search (name of data base and, where practicable, search terms used)
See Search History document

C. DOCUMENTS CONSIDERED TO BE RELEVANT

Category*	Citation of document, with indication, where appropriate, of the relevant passages	Relevant to claim No.
X	US 6,150,472 A (ENGBERS) 21 November 2000 (21.11.2000) entire document	1
---		---
Y		2-19, 24-29, 48, 50-65
Y	US 8,485,662 B2 (COLLINS et al) 16 July 2013 (16.07.2013) entire document	2-18, 24-29
Y	US 2018/0231696 A1 (UNIVERSITY OF ROCHESTER) 16 August 2018 (16.08.2018) entire document	10, 48, 50-65
Y	US 7,828,431 B2 (HO et al) 09 November 2010 (09.11.2010) entire document	15, 24, 57
Y	US 7,057,816 B1 (ALLEN et al) 06 June 2006 (06.06.2006) entire document	19, 62
Y	US 9,329,408 B2 (MATSUNAGA et al) 03 May 2016 (03.05.2016) entire document	25, 61
Y	US 4,990,582 A (SALAMONE) 05 February 1991 (05.02.1991) entire document	50, 65
A	US 9,823,493 B2 (CALDARISE et al) 21 November 2017 (21.11.2017) entire document	1-39, 48, 50-65
A	US 5,523,316 A (GAN et al) 04 June 1996 (04.06.1996) entire document	1-39, 48, 50-65
A	US 2016/0116764 A1 (MENICON SINGAPORE PTE LTD) 28 April 2016 (28.04.2016) entire document	1-39, 48, 50-65

Further documents are listed in the continuation of Box C. See patent family annex.

* Special categories of cited documents:	"T" later document published after the international filing date or priority date and not in conflict with the application but cited to understand the principle or theory underlying the invention
"A" document defining the general state of the art which is not considered to be of particular relevance	"X" document of particular relevance; the claimed invention cannot be considered novel or cannot be considered to involve an inventive step when the document is taken alone
"E" earlier application or patent but published on or after the international filing date	"Y" document of particular relevance; the claimed invention cannot be considered to involve an inventive step when the document is combined with one or more other such documents, such combination being obvious to a person skilled in the art
"L" document which may throw doubts on priority claim(s) or which is cited to establish the publication date of another citation or other special reason (as specified)	"&" document member of the same patent family
"O" document referring to an oral disclosure, use, exhibition or other means	
"P" document published prior to the international filing date but later than the priority date claimed	

Date of the actual completion of the international search
27 November 2019

Date of mailing of the international search report

13 DEC 2019

Name and mailing address of the ISA/US
Mail Stop PCT, Attn: ISA/US, Commissioner for Patents
P.O. Box 1450, Alexandria, VA 22313-1450
Facsimile No. 571-273-8300

Authorized officer
Blaine R. Copenheaver

PCT Helpdesk: 571-272-4300
PCT OSP: 571-272-7774

INTERNATIONAL SEARCH REPORT

International application No.

PCT/US2019/047058

Box No. II Observations where certain claims were found unsearchable (Continuation of item 2 of first sheet)

This international search report has not been established in respect of certain claims under Article 17(2)(a) for the following reasons:

1. Claims Nos.:
because they relate to subject matter not required to be searched by this Authority, namely:

2. Claims Nos.:
because they relate to parts of the international application that do not comply with the prescribed requirements to such an extent that no meaningful international search can be carried out, specifically:

3. Claims Nos.: 40-47, 49
because they are dependent claims and are not drafted in accordance with the second and third sentences of Rule 6.4(a).

Box No. III Observations where unity of invention is lacking (Continuation of item 3 of first sheet)

This International Searching Authority found multiple inventions in this international application, as follows:
See extra sheet(s).

1. As all required additional search fees were timely paid by the applicant, this international search report covers all searchable claims.
2. As all searchable claims could be searched without effort justifying additional fees, this Authority did not invite payment of additional fees.
3. As only some of the required additional search fees were timely paid by the applicant, this international search report covers only those claims for which fees were paid, specifically claims Nos.:

4. No required additional search fees were timely paid by the applicant. Consequently, this international search report is restricted to the invention first mentioned in the claims; it is covered by claims Nos.:

Remark on Protest

- The additional search fees were accompanied by the applicant's protest and, where applicable, the payment of a protest fee.
- The additional search fees were accompanied by the applicant's protest but the applicable protest fee was not paid within the time limit specified in the invitation.
- No protest accompanied the payment of additional search fees.

Continued from Box No. III Observations where unity of invention is lacking

This application contains the following inventions or groups of inventions which are not so linked as to form a single general inventive concept under PCT Rule 13.1. In order for all inventions to be examined, the appropriate additional examination fees need to be paid.

Group I: Claims 1-39 are drawn to ophthalmic lenses.

Group II: Claims 48 and 50-65 are drawn to methods for inducing a refractive index gradient in a three-dimensional polymeric matrix.

The inventions listed in Groups I and II do not relate to a single general inventive concept under PCT Rule 13.1, because under PCT Rule 13.2 they lack the same or corresponding special technical features for the following reasons:

The special technical features of Group I, ophthalmic lenses, are not present in Group II; and the special technical features of Group II, methods for inducing a refractive index gradient in a three-dimensional polymeric matrix, are not present in Group I.

Groups I and II share the technical features of a body made from a copolymer having a three-dimensional polymeric matrix, wherein the three dimensional polymeric matrix has a non-uniform cross-link density. However, these shared technical features do not represent a contribution over the prior art.

US 6,150,472 A to Engbers teaches a body (Col. 1, Lns. 6-12, The present invention relates to multi-functional site containing polymers and applications thereof, in particular gels. Gels have a wide variety of applications ... in contact lenses; Col. 9, Lns. 13-20, applications of gels according to the present invention include ... intra-ocular and contact lenses) made from a copolymer having a three-dimensional polymeric matrix (Col. 1, Lns. 12-20, A hydrogel has been defined ... as a water swollen network (cross-linked structure) of hydrophilic homo-polymers or copolymers with a three dimensional appearance of which the cross-links can be formed by covalent and/or ionic bonds, and/or by van der Waals and/or hydrogen bonds.), wherein the three dimensional polymeric matrix has a non-uniform cross-link density (Col. 1, Lns. 34-55, Typical monomers that are used in the latter approach are methacrylates like hydroxyethyl methacrylate (mono-functional) and ethylene glycol dimethacrylate (bi-functional/multi-functional). Characteristics of the obtained gel are determined by the choice of polymer/monomer(s) used for its preparation, the degree and positioning of cross-linking and the solvent used for swelling of the network. ... Cross-linking occurring randomly along the polymer chain causes that a polymer network is obtained with a non-uniform length between cross-links.; Col. 3, Lns. 15-19, control over the degree and positioning of cross-linking is achieved, whereby a gel with a pre-determined network structure is yielded whereby control over the gel's characteristics, such as permeability, swelling and strength, is achieved).

The inventions listed in Groups I and II therefore lack unity under Rule 13 because they do not share a same or corresponding special technical feature.