

R. WEISS.
EMBROIDERING MACHINE.

No. 521,197.

Patented June 12, 1894.

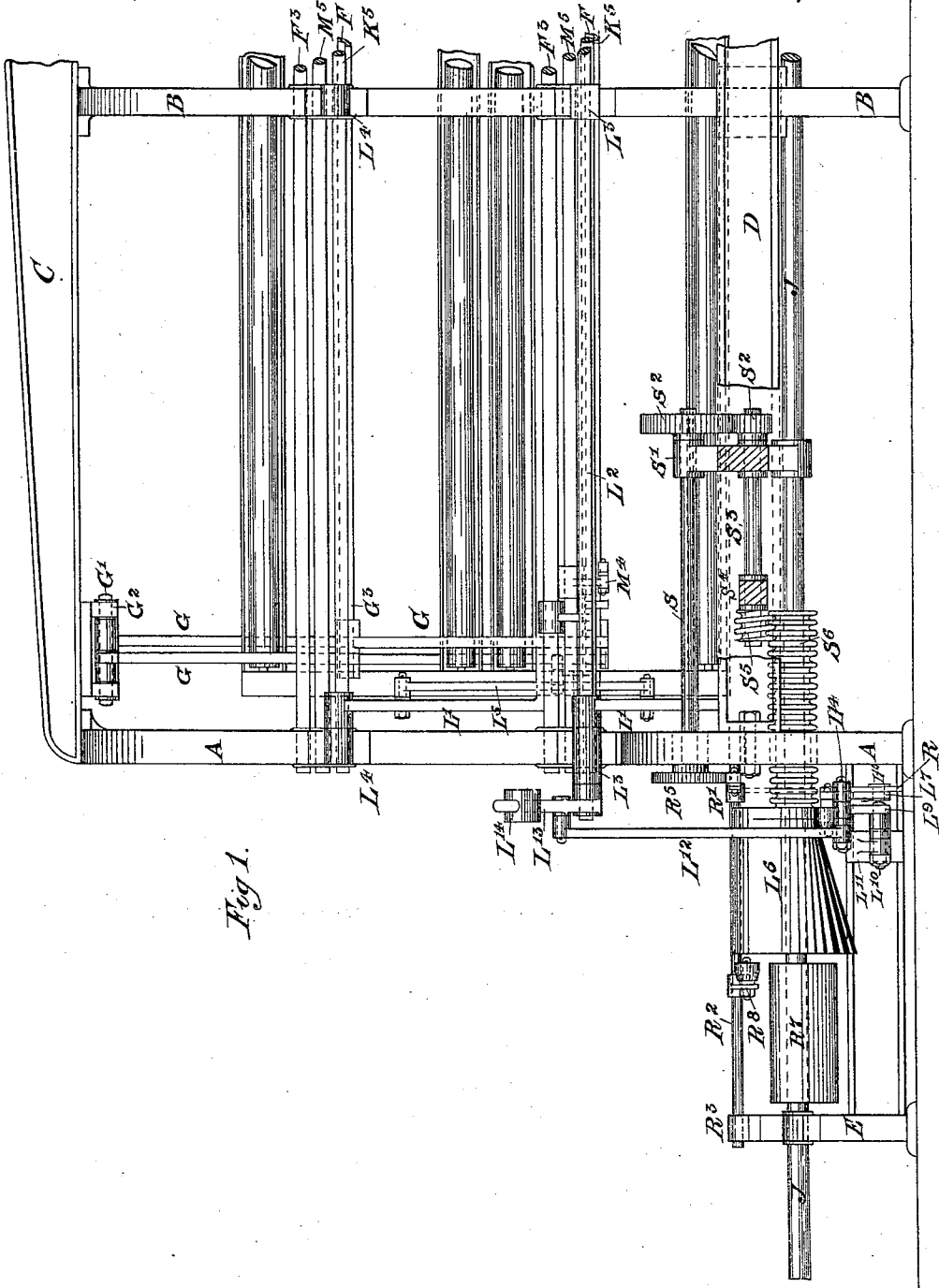

Fig 1.

Witnesses:
Alvan Macaulay
E. D. Smith

Inventor
Rudolph Weiss
 By *Church & Church*
 His Atty's

R. WEISS.
EMBROIDERING MACHINE.

No. 521,197.

Patented June 12, 1894.

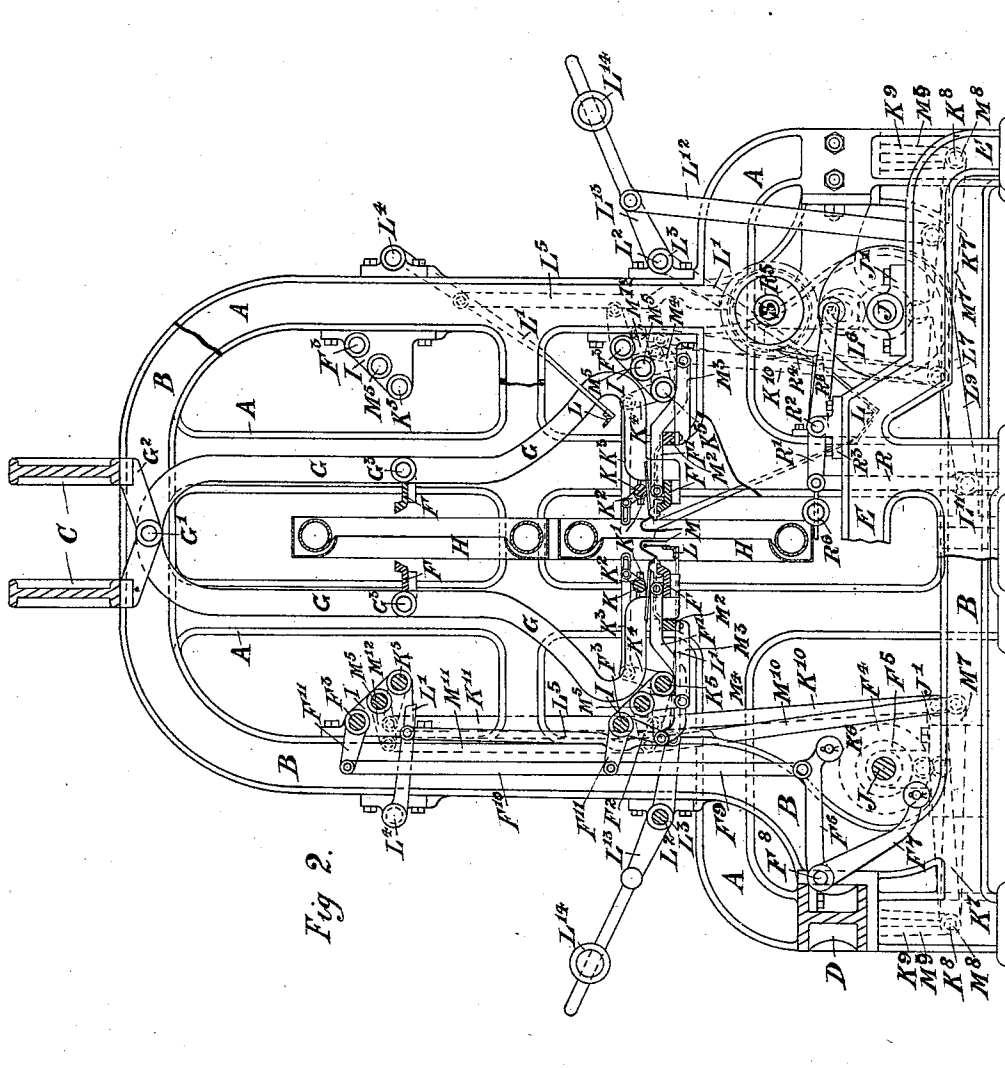

Fig 2.

Witnesses
Alvan Macauley
O B Smith

Inventor
Rudolph Weiss,
 By *Church & Church*
Attys

R. WEISS.
EMBROIDERING MACHINE.

No. 521,197.

Patented June 12, 1894.

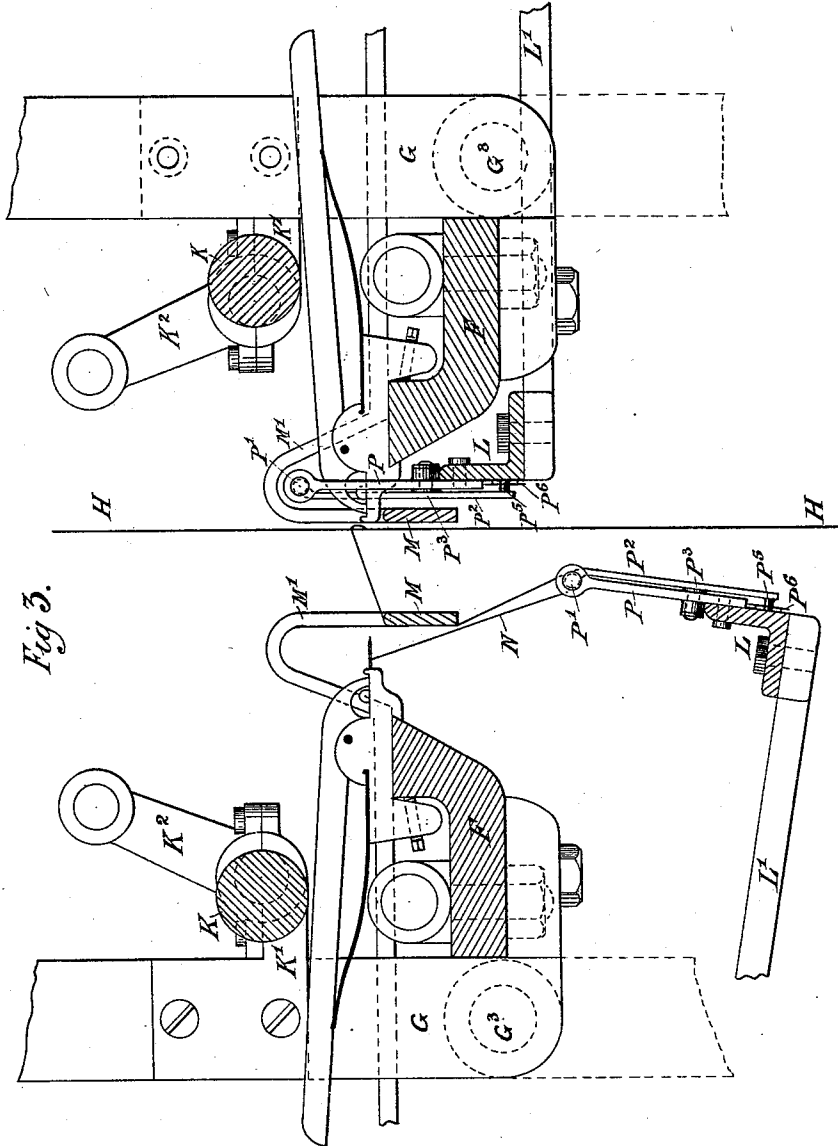

Witnesses
 Alvan Macauley
 J. B. Smith

Inventor
 Rudolph Weiss,
 By Church & Church,
 His Attys.

R. WEISS.
EMBROIDERING MACHINE.

No. 521,197

Patented June 12, 1894.

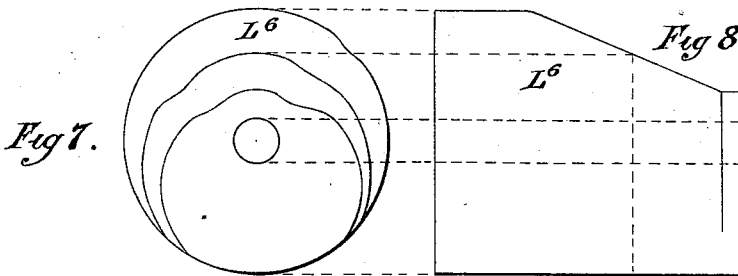
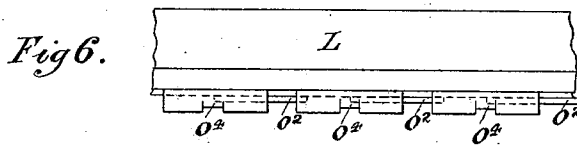
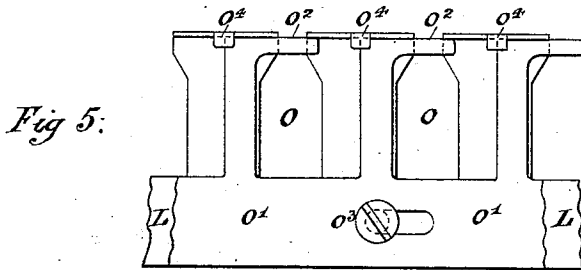
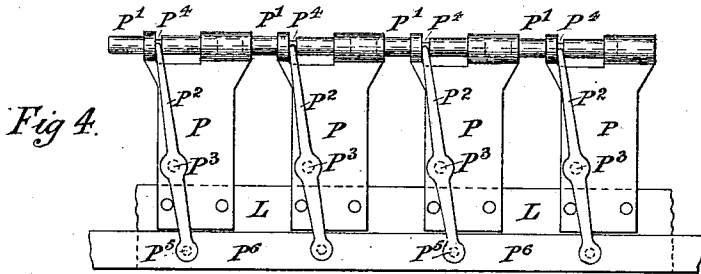

Witnesses
Alvan Macaulay
E. B. Smith

Inventor
Rudolph Weiss,
 By *Church & Church.*
his Atty

R. WEISS.
EMBROIDERING MACHINE.

No. 521,197.

Patented June 12, 1894.

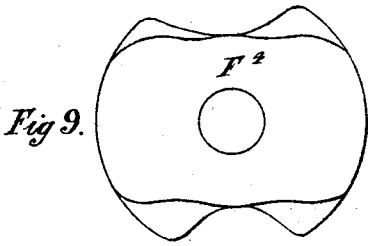

Fig 10.

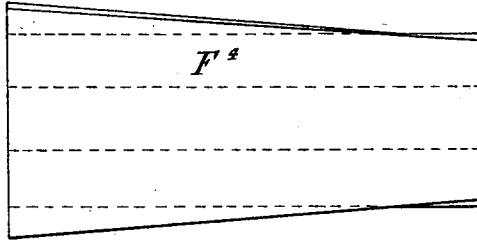

Fig 14.

Fig 15.

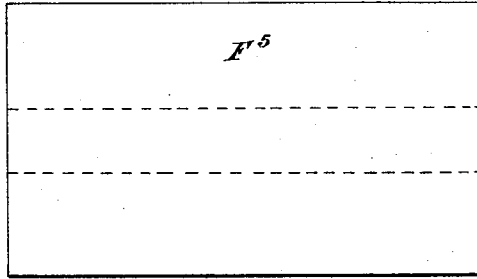
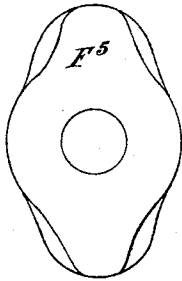

Fig 16.

Fig 17.

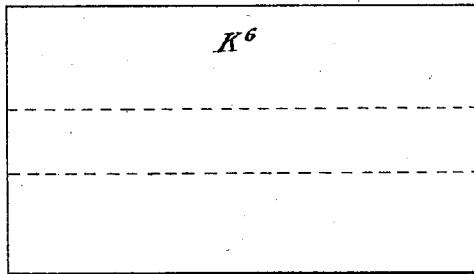
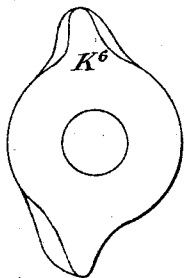
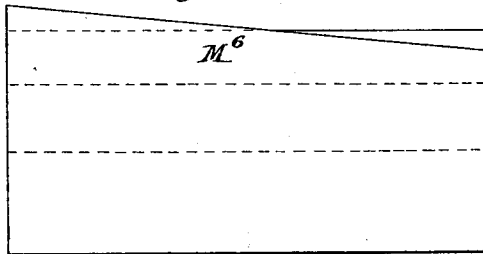
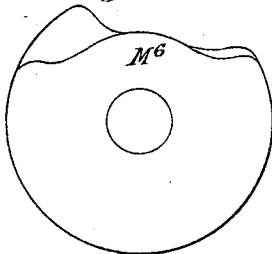

Fig 20.

Fig 21.



Witnesses
Otho Maenley
E. J. Smith.

Inventor
Rudolph Weiss,
By Church & Church,

his Atty.

R. WEISS.
EMBROIDERING MACHINE.

No. 521,197.

Patented June 12, 1894.

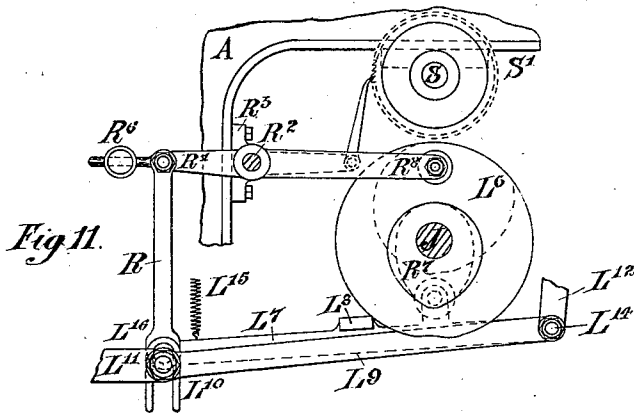

Fig. 11.

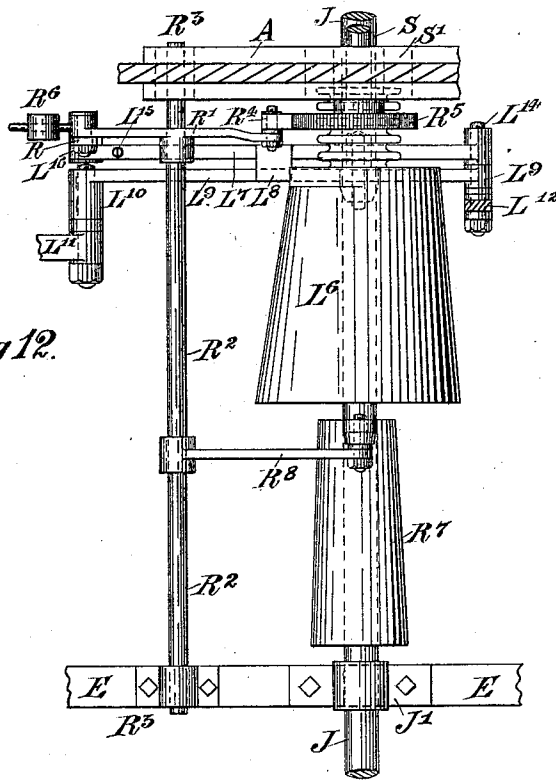

Fig. 12.

Witnesses
 Alvan Macaulay
 E. D. Smith

Inventor
 Rudolph Weiss.
 By Church & Church,
 his Attys

(No Model.)

8 Sheets—Sheet 7.

R. WEISS.
EMBROIDERING MACHINE.

No. 521,197.

Patented June 12, 1894.

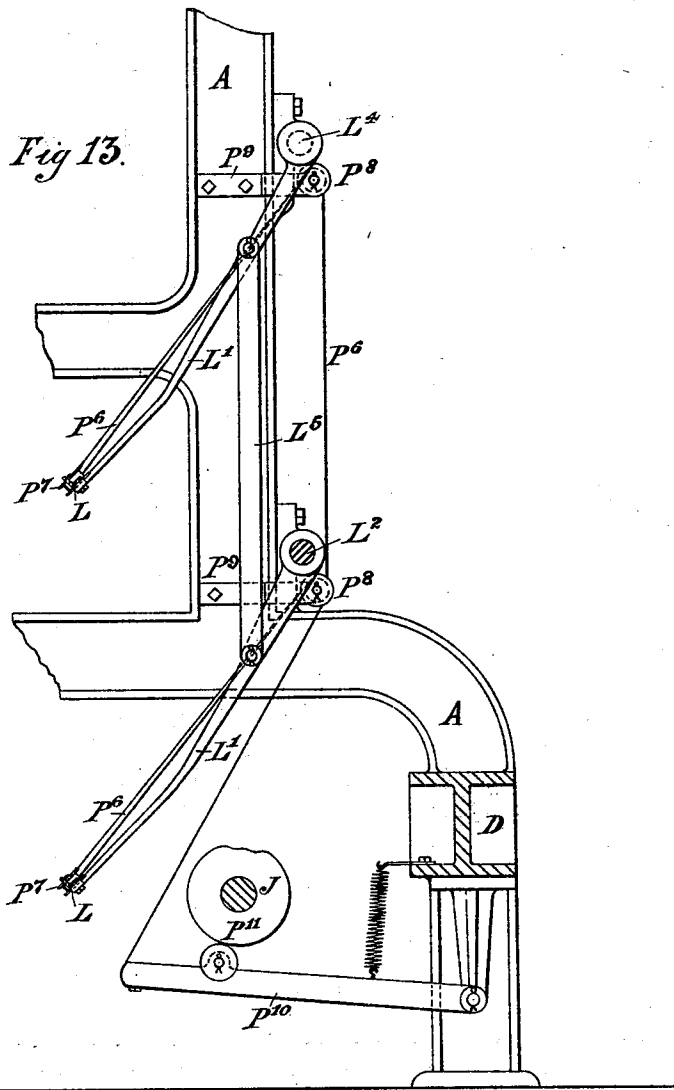

Witnesses
 Othau Macaulay
 E. D. Smith

Inventor
 Rudolph Weiss,
 By Church & Church,
 his Attys.

R. WEISS.
EMBROIDERING MACHINE.

No. 521,197.

Patented June 12, 1894.

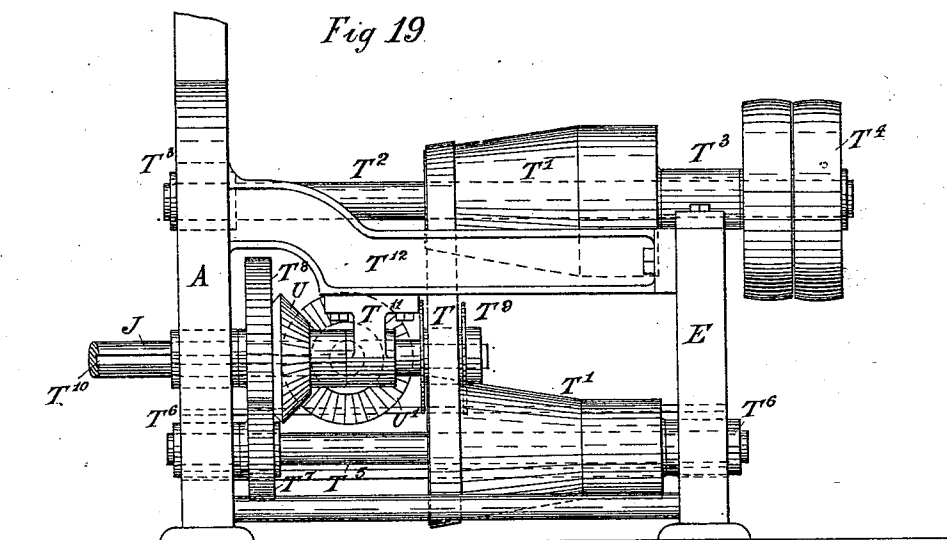
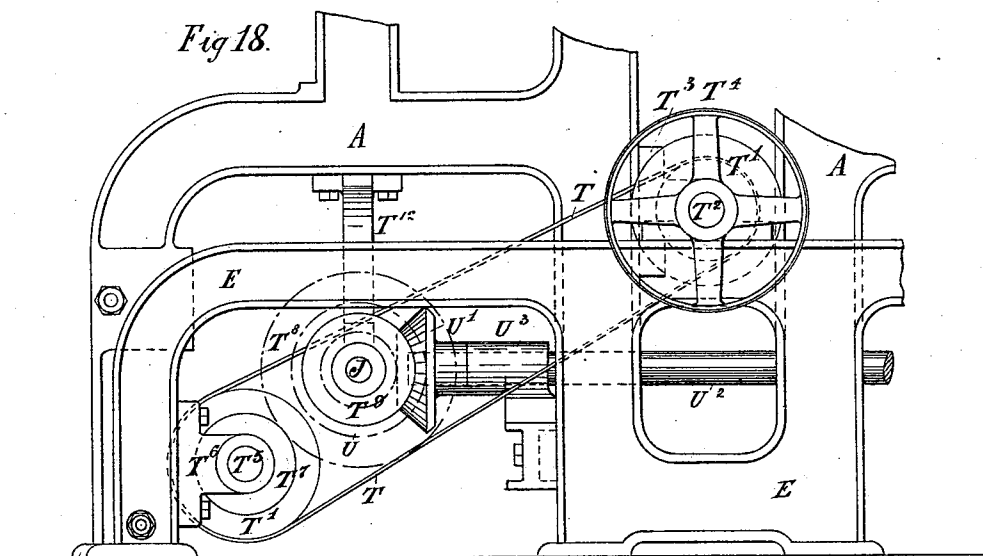

Witnesses
 Otho Macaulay
 E. D. Smith

Inventor
 Rudolph Weiss,
 By Lechur & Lechur,
 his Attys

UNITED STATES PATENT OFFICE.

RUDOLPH WEISS, OF NOTTINGHAM, ENGLAND.

EMBROIDERING-MACHINE.

SPECIFICATION forming part of Letters Patent No. 521,197, dated June 12, 1894.

Application filed February 20, 1891, Serial No. 382,214. (No model.) Patented in England May 6, 1890, No. 7,031; in France February 9, 1891, No. 211,275; in Switzerland February 10, 1891, No. 3,477; in Belgium February 11, 1891, No. 93,726, and in Austria-Hungary July 21, 1891, No. 10,029 and No. 25,753.

To all whom it may concern:

Be it known that I, RUDOLPH WEISS, a subject of the Queen of England, residing at Nottingham, England, have invented certain new and useful Improvements in or Relating to Embroidery-Machines, of which the following is a specification, the same having been patented to me in France, No. 211,275, February 9, 1891; in Belgium, No. 93,726, February 11, 1891; in Switzerland, No. 3,477, February 10, 1891; in Austria-Hungary, No. 10,029 and No. 25,753, July 21, 1891, and in England, No. 7,031, May 6, 1890.

This invention relates to embroidery machines in which the material to be embroidered is carried on a framing which is moved by a pantograph operated by an attendant or other means and in which series of double pointed needles are employed provided with threads of a limited length which are alternately passed entirely through the fabric and received by series of jaws or nippers arranged on each side of the fabric. It will be best understood by reference to the accompanying drawings, in which—

Figure 1 is a front elevation of the left hand end of the machine. Fig. 2 is an end elevation partly in section. Fig. 3 is a cross section of part of the upper tier of the needle operating mechanism and the tissue or material being embroidered. Fig. 4 is a front view of part of one of the take-up bars. Figs. 5 and 6 are an elevation and a plan respectively showing modification of a take-up bar. Figs. 7 and 8 are an end and a side elevation respectively of a take-up cam. Figs. 9 and 10 are an end and a side elevation respectively of a nipper-carrying-bar-cam. Figs. 11 and 12 are an elevation and a plan respectively showing detail of take-up regulating devices. Fig. 13 is a side elevation showing detail of the take-up mechanism. Figs. 14 and 15 are an end and side elevation respectively of the nipper-carrying bar counter cam. Figs. 16 and 17 are an end and side elevation respectively of the nipper-releasing shaft cam. Figs. 18 and 19 are a side and front elevation respectively of the driving mechanism at the right hand end of the machine, and Figs. 20 and 21 are an end and side elevation respectively of one of the support bar-cams.

The machine as described is adapted to operate an upper and lower tier of needles which tiers are in part identical with each other. The upper tier is also operated simultaneously with its corresponding lower tier and by the same cams, it will also be understood that the back of the machine is mainly a copy of the front and that the following which is a description of the front applies also substantially to the back where not otherwise stated.

The framing of the machine consists essentially of two end standards A and intermediate standards B connected by tie-bars C at the top and by rails D at the front and back also outside the end standards A are reduced standards E connected to the end standards by suitable cross stays.

The nipper-carrying bars F are supported by hangers G those of the upper tier being pivoted at G' in brackets G² secured to the tie-bars C and those of the lower tier at G³ to the hangers G of the upper tier the said hangers being thus free to move or swing to or from the material or tissue H hereinafter called the tissue.

Motion is imparted to the nipper-carrying-bars F by links F' connected to levers F² secured on rocking shafts F³ carried in bearings I secured to the framing; motion is imparted to the rocking shaft F³ by means of cams F⁴ and F⁵ secured on the cam shaft J which is carried in bearings J' secured to the framing. The cams F⁴ and F⁵ are in peripheral contact with antifriction rollers pivoted on lever F⁶ and arm F⁷ secured to a shaft F⁸ journaled in bearings carried preferably by the rail D the lever F⁶ is connected by links F⁹ and F¹⁰ to arms F¹¹ secured to the rocking shafts F³; by this means a positive motion is obtained both for the "in" and "out" movement of the bars F the cam F⁵ being cut so as to act as a counter-cam to the cam F⁴.

The needle nippers may be operated so as to release the needles by means of eccentric shafts K carried in bearings K' secured to the hangers G which shafts are turned through a sufficient space to depress the tails of the nippers when required by means of arms K² secured thereto connected by preferably slotted links K³ to arms K⁴ secured to rocking shafts K⁵ carried in the bearings I. Motion is im-

parted to the rocking shafts K^5 by a cam K (Figs. 16 and 17) secured on the cam shaft J operating a lever K^7 which is pivoted at K^8 to a bracket K^9 secured to the rail D and at its free end is connected by links K^{10} and K^{11} to the rocking shafts K^5 .

The take-up bars L of special construction hereinafter described are carried by arms L' secured in the case of the lower tier on a rocking shaft L^2 carried in bearings L^3 secured to the framing and in the case of the upper tier may be pivoted on independent pivots L^4 secured to the framing the arms L' of the upper and lower tiers being connected by links L^5 and are thus operated simultaneously by the rocking shaft L^2 both upper and lower sets of arms L' may however be carried on rocking shafts or on independent pivots and in the latter case actuated by a rocking shaft arranged at any convenient part of the machine through any suitable mechanical arrangement. The rocking shaft L^2 is actuated by a cam L^6 secured on the cam shaft J operating through an antifriction roller a supplementary lever L^7 provided with a projection L^8 which engages with and operates the lever L^9 . This lever is pivoted at L^{10} to a bracket L^{11} secured to the framing and is connected at its free end by a link L^{12} to an arm L^{13} secured on the shaft L^2 . The take-up bars L may be counterbalanced by means of weights L^{14} adjustable on arms L^{13} secured on the shaft L^2 , if desirable such weights may be moved or adjusted by the attendant working the pantograph, by this means the tension put on the threads by the take-up bar L may be regulated to suit different kinds of stitches or tissue.

The support bars M are arranged with their upper edges immediately below the needles and the threads drawn over them by the take-up so that the said threads are drawn at right angles, or nearly so, through the tissue, for this purpose also they are withdrawn from the tissue each stitch a sufficient distance. They are carried by brackets M' which pass over the nipper-carrying-bars F and are secured to a bar M^2 actuated by links M^3 connected to arms M^4 secured on the rocking shaft M^5 carried in the bearings I . The rocking shafts M^5 are operated by a cam M^6 (Figs. 20 and 21) secured on the cam shaft J actuating through an antifriction roller a lever M^7 pivoted at M^8 to a bracket M^9 secured to the rail D and connected at its free end by links M^{10} and M^{11} to the levers M^{12} secured to the shafts M^5 . The parts M^8 and M^9 are immediately behind the corresponding parts K^8 and K^9 in Fig. 2.

In embroidery machines of this description where the needles are always withdrawn the same distance from the tissue, it is necessary to provide a take-up for drawing the threads through the tissue.

In my improved arrangement the take-up bar L of which there are two to each tier of needles are arranged so that the stitches can be made from that side of the tissue where

the take-up bars are in their lower position and the needles pass through to the side where the take-up bars are in their highest position; as the take-up bars on the side to which the needles have passed descend to draw the threads N through the tissue the bars on the other side are raised thus keeping the threads N always in tension or nearly so which prevents them from kinking. With this movement the take-up bars must be constructed so as to release the threads when they approach their upper position. To effect this the bars L may be constructed in the following manner (see Figs. 3 and 4): On the take-up bars and corresponding to the number and position of the needles are secured brackets P extending upward, each bracket is provided at its upper end with a sliding pin or bolt P' adapted to slide out of and engage in a corresponding recess in the one next to it thus closing the space between the brackets. The bolts P' may be operated as shown by levers P^2 pivoted at P^3 on the brackets P the upper ends of which engage in annular recesses P^4 in the pins P' and provided at their lower ends with pins or projections P^5 which engage with a bar P^6 which is shogged against the action of a spring. The needles pass through the tissue and through the space between the brackets P below the level of the bolts P' which thus retain the threads N as the bar descends, as the take-up bars on the other side of the tissue approach their upper position the bolts P' may be withdrawn to release the threads by shogging the bar P^6 and again closed so that a stitch can be immediately made from the other side. With this arrangement the movement of the take-up bars is reduced to the simplest form and immediately the bars on one side reach their lower position and the bars on the other side of the tissue their upper position a fresh stitch can be made. The bars P^6 are preferably formed of thin steel known as "steel bar" and may be connected by one of their ends to a spring secured to its corresponding take-up bar L and the remaining ends (see Fig. 13) after passing over a pulley P^7 pivoted to the opposite end of the bar to which the spring is secured, and a pulley P^8 pivoted to a bracket P^9 secured to the framing, are secured to the free end of the lever P^{10} actuated by a cam P^{11} secured to the cam shaft J . The releasing movement is thus independent of the take-up movement and the threads can be released when the take-up bars are in any position or when they are at rest.

In a modification shown in Figs. 5 and 6 a take-up bar L may be formed as shown with openings O corresponding to the position of the needles, sliding on the bar L is a bar O' provided with upward extensions at the upper ends of which are extensions or bolts O^2 which are of sufficient length to close the reduced width of the opening O at the top when shogged on the bar L , the bar O' may be retained in position by screws O^3 passing

through slots in its lower part and at the upper part by ears O⁴ on the bar L turned down over the bar O'. The bar O' may be shogged by a steel bar or other flexible connection in the same manner as hereinbefore described against the action of a spring.

I do not however confine myself to the precise arrangement of take-up bars set forth as it is obvious that numerous other arrangements may be employed for retaining and releasing the threads.

The surfaces of the take-up cams L⁶ (see Figs. 7, 8 and 12) are formed of a considerable length and cut with a gradually reducing motion toward one end so that as the length of thread in the needles is reduced the cam by changing its position with respect to the antifriction roller in peripheral contact therewith will produce a corresponding decrease in the motion or stroke of the take-up bars. To effect this automatically the antifriction roller of each cam is pivoted on the supplementary lever L⁷ (see Figs. 1, 2, 11 and 12) which is pivoted on the connecting pin L¹⁴ of the lever L⁹ and link L¹². The lever L⁷ is provided with the projection L⁸ which engages with and depresses the main lever L⁹ thus raising the take-up bars. As the threads in the needles decrease in length as they are worked into the tissue they will stop the take-up bars before they reach their lowest position with respect to the relative positions of the cam and antifriction roller and the main lever will consequently stop but the supplementary lever L⁷ by reason of the action of the spring L¹⁵ will follow the cam and its free end L¹⁶ will consequently rise turning about its pivot L¹⁴. The free end L¹⁶ of the lever L⁷ engages with the lower forked end of a link R connected at its upper end to a lever R' secured on the shaft R² carried in bearings R³ secured to the framing, the inner end of the lever R' is provided with a pawl R⁴ which engages with the ratchet wheel R⁵, as the inner end of the lever R' is raised against the action of the counterweight R⁶ through the link R by the lever L⁷ its outer end and pawl R⁴ will descend and is again raised by a cam R⁷ secured to the cam shaft J acting on the antifriction roller pivoted on the lever R³ which is secured on the shaft R² thus turning the ratchet wheel R⁵ through a space corresponding to the distance the inner end of the lever R' is raised and returning the latter together with the lever L⁷ to their normal positions. The ratchet wheel R⁵ is secured on a shaft S carried in bearings S' secured to the framing and is connected at its inner end by spur wheels S² to a shaft S³ carried in the bearings S' and S⁴. The shaft S³ is provided with a worm S⁵ which engages with the annular rack S⁶ on the cam shaft J which is thus moved longitudinally by turning the ratchet wheel R⁵. By this means the relative positions of the cam L⁶ and antifriction roller in peripheral contact therewith will be automatically changed and the motion of

the take-up bars will be constantly reduced so as to correspond to the constantly reducing length of thread in the needles and such reduction of the motion of the take-up bars will be governed by the threads as their length is reduced. As the length of the threads in the needles decreases less motion or strokes of the take-up bars is required and consequently a less number of the three hundred and sixty degrees of each revolution of the cam are wanted for that movement, the degrees thus not required by reason of the reduction of the motion of the take-up bars not wholly going to increase the number of the degrees of rest but at different positions in the length of the cam being distributed between the movement-giving degrees and the degrees of rest the speed of the cam shaft may be increased without increasing the speed of the take-up bars or altering the length of the period during which they are at rest.

By "speed of the take up bars" is meant the number of movements per minute, as it is obvious that if the speed of the cam shaft is increased it will increase the number of strokes per minute. Advantage is taken of the fact that at each succeeding stitch the length of movement of the take up bars is decreased and in proportion to the decrease of the length of movement of the take up bars, the number of strokes per minute are increased and consequently more stitches are made per minute as the needle threads become shorter. By the employment of a cam, however, such as described, in which the movement giving degrees and the degree of rest are re-distributed in different parts of its length, although the speed of the cam shaft is increased, as the take up bars move through a shorter arc or path, less time is required for each movement and therefore the actual velocity or speed at which the take up bars travel along the path is not accelerated. For example. If the machine starts with a forty inch length of thread in each needle, fifteen stitches per minute may be made as the take-up bars travel along a path twenty inches long. When the threads are reduced to twenty inches the take-up bars will only travel along a path ten inches long and will consequently travel much slower or the period of rest will be increased, only half the time being now required for the take-up, this time may therefore be saved by the arrangement described and a consequent increase is obtained in the amount of work the machine will produce. As it is not desirable to decrease the length of the period of rest between each movement, the cam is graduated in this respect so to counteract the increased speed of the cam-shaft, the remaining cams are also graduated so that their movement giving degrees are increased so as to counteract the increased speed of the cam-shaft, while their degrees of rest are correspondingly decreased. When the period of rest on the take up cam is in operation, the move-

ment giving degrees of the remaining cams will be in operation and consequently the period of rest of the take-up bars and period in which the remaining parts are in action will coincide and the length of time for each will remain constant throughout. The movement giving degrees of the take-up cam will in like manner coincide with the degrees of rest on the remaining cams and the decrease in the time occupied by the movement of the former will coincide with the decrease of the periods of rest on the latter.

To increase the speed of the cam shaft the driving belt T may run on coned pulleys T' Figs. 18 and 19 the upper one of which is secured on a shaft T² carried in bearings T³ secured to the framing and provided with fast and loose pulleys T⁴ the lower pulley T' is secured on a shaft T⁵ carried in bearings T⁶ secured to the framing and is connected to the front cam shaft J by spur wheels T⁷ and T⁸. The belt T is moved on the pulleys T' by a fork or flanged pulley T⁹ rotating on the cam shaft J which by its lateral movement decreases the motion of the take-up bars and by moving the belt T increases the speed of the cam shaft to an amount which is regulated by the shape of the pulleys T'.

As it is not desirable to increase the speed of any of the working parts of the machine as the duration of the length of rest of the take-up bars is uniform it will be necessary to compensate for the increased speed of the cam shaft. This I am enabled to do by employing cams of a length equal to the take-up cams and receiving the same longitudinal movement as the take-up cam and cam shaft J, these may be graduated toward one end (as shown in Figs. 9, 10, 14, 15, 16, 17, 20 and 21) so that although imparting the same motion throughout to the cam levers working in connection therewith the number of the degrees of motion are increased to correspond to the increased number of the degrees of rest on the take-up cam and the number of degrees of rest are correspondingly decreased to correspond to the decreased movement of the take-up bars.

To prevent the cam levers from being strained by the longitudinal motion of the cam shaft and the inclined surfaces of the cams their free ends may be adapted so as to work in vertical guides of suitable construction preferably secured to the framing.

The spur wheel T³ is provided with a feather engaging with a longitudinal groove or keyway T¹⁰ in the cam shaft J which is thus free to slide longitudinally through the wheel T³ which is held in position by the bearing T¹¹ secured to the cross stay T¹²; secured to the spur wheel T³ is a motive wheel U in gear with a corresponding wheel U' secured to the cross shaft U² carried in bearing U³ secured to the framing, this shaft communicates motion to the back cam shaft by means of another pair of miter wheels and a simi-

lar arrangement as shown in connection with the front shaft.

It is obvious that if the cam shaft was run at the same speed throughout it would not be necessary to employ graduated cams except in connection with the take-up which cam could be adapted to slide laterally on the cam shaft the remaining cams being of ordinary construction.

I wish it understood that I do not bind myself to the precise construction of apparatus herein described and shown in the accompanying drawings as many parts may be modified without departing from the spirit of the invention.

I claim—

1. In an embroidery machine, the combination with the thread carrying needles and operating mechanism, of the movable take up bar L carrying movable bolts for holding and releasing the threads; substantially as described.

2. In an embroidery machine, the combination with the thread carrying needles and operating mechanism, of the movable take up bar L carrying a series of bolts for holding the threads connected for simultaneous movement, with means for operating said bolts; substantially as described.

3. In an embroidery machine, the combination with the thread carrying needles, and operating mechanism, of the movable take up bar having recesses or openings therein for the passage of the needles and the members moving across said recesses or openings to hold the threads therein; substantially as described.

4. In an embroidery machine, the combination with the thread carrying needles and operating mechanism, of the bar L, brackets P, sliding bolts P' levers P² and bar P⁶ forming a take up bar; substantially as described.

5. In an embroidery machine, the combination with the thread carrying needles and operating mechanism of the take up bar, the movable bolts on said bar for holding the threads, the flexible connection P⁶ for moving the bolts, pulley P³ lever P¹⁰ and cam P¹¹; substantially as described.

6. In an embroidery machine, the combination with the thread needles, operating mechanism therefor, movable take up bar and its movement transmitting connections, of an actuating cam L⁶ cooperating with said take up bar movement transmitting connections, said cam imparting the complete back and forth movements to the take up bar between successive stitches, and having its cam surface graduated at right angles to its plane of rotation, with automatic means for shifting the relative positions of the cam and take up bar movement transmitting connections, longitudinally of the axis of the cam, whereby the length of the back and forth movement imparted to said bar as produced by said cam, is varied to compensate for the varying length of the thread; substantially as described.

7. In an embroidery machine, the combination with the thread needles, operating mechanism therefor, a take up, a lever L⁹ for operating said take up and an operating cam having its cam surface graduated at right angles to its plane of rotation, of the lever L⁷ moved by the cam and cooperating with the lever L⁹ to move the same and mechanism operated by the lever L⁷ for shifting the relative position of the cam and lever L⁷ whereby the length of the movement of the cut-off may be varied; substantially as described.

8. In an embroidery machine, the combination with the thread needles, operating mechanism cam, take up, and lever L⁹ of the lever L⁷, lever R' connected therewith, the ratchet wheel R⁵ for shifting the relative positions of the cam and lever L⁹ and the pawl R⁴ moved by the lever R' and engaging said wheel; substantially as described.

9. In a take up bar operating mechanism, the combination with the take up bar, its operating lever and cam cooperating therewith movable with relation to each other, of the ratchet wheel R⁵ and worm connected therewith for changing the relation of the cam and lever, the lever L⁷, link R, lever R' carrying pawl R⁴, shaft R² arm R³ and cam R⁷ for operating said arm; substantially as described.

10. In a take up bar operating mechanism, the combination with the take-up bar its operating lever and the movable cam cooperating therewith, of the ratchet wheel R⁵, shafts S and S³ connected by worm gear and rack and a pawl and operating lever therefor for moving said ratchet wheel controlled by the take up bar operating lever; substantially as described.

11. In an embroidery machine, the combination with the needle nippers and the bar F on which they are mounted, of the pendent pivoted hangers G carrying the bar F at their lower ends; substantially as described.

12. In an embroidery machine, the combination with the nippers, take up bars, their operating cam having a variable movement and the nipper-carrying bar F, of a cam F⁴ for operating the nipper carrying bar, which cam is graduated, the number of movement giving degrees being increased in different parts of its length to compensate for the increased speed of the take-up bar operating cam as the length of the movement of the take-up bars decreases; substantially as described.

13. In an embroidery machine, the combination with a nipper and the nipper carrying bar F, of cams such as F⁴ and F⁵ operating the said bar F, levers F⁶ arm F⁷ shaft F⁸, link F⁹ and arm F¹¹ secured to the shaft F⁸; substantially as described and illustrated in the accompanying drawings.

14. In an embroidery machine, the combination with the take up bars having a variable movement, the nippers, nipper carrying bar and nipper releasing shaft K, of a cam K⁶ for operating the said shaft K which cam is graduated the number of movement giving degrees being increased in different parts of its length so as to compensate for an increased speed of the cam as the length of movement of the take up bars is increased substantially as described and illustrated in the accompanying drawings.

15. In an embroidery machine, the combination with the needles, take up bars and support bar, of an operating mechanism for said support bar M consisting of rocking shaft M⁵ arm M⁴ link M³ bar M² brackets M' and means for operating rocking shaft M⁵ substantially as described and illustrated in the accompanying drawings.

16. In an embroidery machine, the combination, with the needles, take up bars having a variable movement, and support M, of a cam M⁶ for operating the said bar M graduated, the number of movement giving degrees being increased in different parts of its length so as to compensate for an increased speed of the cam as the length of movement of the take-up bars is decreased substantially as described and illustrated in the accompanying drawings.

17. In an embroidery machine, the combination with the needles, and take-up bars having a variable movement, of a power transmitting mechanism for increasing the speed of the machine as the movement of the take up bars decreases, consisting of cone pulleys T⁷ shafts T² and T⁵ pulleys T⁴ and actuating belt substantially as described and illustrated in the accompanying drawings.

In testimony whereof I have hereto set my hand in the presence of the two subscribing witnesses.

RUDOLPH WEISS.

Witnesses:

F. C. SHELDON,
JOSEPH PLAYER.